





# THE ELECTRICAL AGE

VOLUME XXXIX

January—December, 1908

NEW YORK AND LONDON

p. 305  
 b. 38  
 3821

## INDEX TO VOLUME XXXIX

	PAGE		PAGE
<b>JANUARY</b>			
Public Service Commission, New York.....	1	The Professional Electrical Course.....	37
Power Rating of Generators.....	1	The Westinghouse Situation.....	37
The Tungsten Filament.....	1	The Tungsten Filament.....	37
A New Storage Cell.....	2	The Step Bearing.....	37
The Central Station Distributing System.....	2	The Central Station Distributing System.....	38
Personality .....	2	Electric Locomotive Rail Pressure.....	43
The Estimation of Power-Factor on Unbalanced Three-Phase Loads.....	3	French Underground Cables.....	43
The Central Station Distributing System-Feeder Calculations .....	5	A Peculiar Turbine Trouble.....	44
Modern Arc Lighting.....	9	Electrolysis .....	45
Systematic Testing of Oil in Transformers, and Methods of Reclaiming Oil for Service.....	13	An Odd Case of a Motor Dropping Its Load.....	53
Single-Phase Textile Motor Installation.....	15	The Application of Electric Power to Pulp and Paper Mills..	54
The Rosenberg Generator.....	17	The Westinghouse Electrically Heated Sad-Iron.....	60
Tungsten Series Incandescent Lamps at Grosse Point, Mich..	18	The Electric Drive in a Hardware Factory.....	60
Electric Locomotives—Continued.....	19	<b>MARCH</b>	
Electric Motor Connections.....	25	Illuminating Engineering.....	61
Selling Currents.....	26	Non-Synchronous Generators.....	61
Questions and Answers.....	27	Standard Handbook for Electrical Engineers.....	62
Review of the Technical Press.....	29	House Bill No. 10457.....	63
Westinghouse Reorganization Plan.....	29	The Central Station Distributing System Pressure Regulation .....	64
A New Recording Millivolt Meter and Shunt Ammeter.....	30	Some Points in the Connecting and Repairing of Alternating Current Motors.....	70
The 1908 Cooper-Hewitt Lamp.....	31	Investigation by the Public Service Commission of the Lighting Companies of New York.....	74
The Tungsten Electric Lamp Company.....	31	Study Men.....	75
Belles Letters.....	32	Some Points about Series Transformers.....	77
Legal Notes.....	33	Commercial Day Program, N. E. L. A. Convention, 1908....	78
<b>FEBRUARY</b>		Questions and Answers.....	79
Water Powers of the Southern Appalachian System.....	35	Electrolytic Copper Refining.....	79
The Decker Cell.....	35	Downward Illumination.....	80
Mica .....	36	Legal Notes.....	82
		New Type of High-Speed Steam Engine.....	83

	PAGE
Large Electrical Machines Built at West Allis Works, Allis-Chalmers Company.....	84
Electric Equipment of Hydro-Electric Plant.....	85
New Madeline Furnace of the Inland Steel Co., Indiana Har- bor, Ind.....	85
Weston Portable Instruments.....	85
Remarkable Performance of an Induction Motor.....	86
General Electric Earns \$9,800,000.....	86
Joints .....	86

APRIL

Electricity from Coal.....	87
The Delmar Short-Circuit Indicator.....	89
New Patent Laws in Britain.....	89
The Lighting of the Institute Library.....	89
A Half Decade of Steam Turbine.....	89
Central Station Distributing System.....	90
Cost of a Single-Phase Line Equipment.....	96
The Richmond and Chesapeake Bay Single-Phase Railway, Richmond, Va.....	97
A Short-Circuit Interrupter.....	99
The Problem of Illumination.....	100
Downward Versus Horizontal Illumination.....	105
Electric Locomotives—Continued.....	106
Long Acre Company Hearing.....	109
Legal Notes.....	110
A New Type of Induction Motor.....	111
Aids to the Solution of Practical Illuminating Problems.....	111
The Bristol Company.....	112
A New Vertical Pump.....	112
Steam Turbine Sales.....	113
New Allis-Chalmers Alternator for Nevada-California Power Company, Goldfield, Nevada.....	113
Incandescent Lamps for Singer Building, New York.....	113

JUNE

General Electric Company's Report.....	115
Downward vs. Horizontal Illumination.....	115
The Boron Jewel.....	116

	PAGE
Sapphire and Diamond Jewels.....	117
Meter Department of the Central Station.....	118
Cable Insulation.....	127
Compensators for Measuring Line Drop.....	133
Questions and Answers.....	134
Lamp Testing.....	134
General Electric Report.....	135
New Breakdown Rate for New York.....	137
American Circular Loom Co.....	137
The Copper Handbook.....	138
Large Railway Motor Contracts.....	138
The General Electric Tungsten Lamp.....	138
Westinghouse Turbines for Manila and Japan.....	138
Low Lighting Rates for Lafayette, Ind.....	138
Williamsburgh Bridge Cables.....	138

JULY

Returning Prosperity.....	139
Westinghouse Readjustment is a Success.....	139
The Transformer Station.....	140
The Copper Situation.....	140
The N. E. L. A. Gas Engine Report.....	140
Motor for Steel Mills.....	140
Testing Lamps by Substitution.....	141
Some Points to be Considered in the Purchase of Steam Turbines .....	142
The Central Station Distributing System.....	144
Tape .....	151
Receiving Stations Operated from High-Tension Transmis- sion Lines.....	153
Distribution in Suburban Districts.....	161
Questions and Answers.....	162
The Western Electric Company Enters the Steam Turbine Field .....	162
The National Electric Light Convention.....	163

AUGUST

The Development of the Regulating Converter.....	165
John A. Roebing.....	165

	PAGE
Motor Control System.....	165
Kokomo, Marion & Western Traction Co.....	166
Setting a Market Value on a Water-Power Plant.....	166
Power Station Lighting.....	166
Southern Water Power.....	166
Protective Devices.....	167
Printing Press Data.....	172
Ground Detectors.....	173
Notes on Power Station Lighting.....	174
The Synchronous Regulating Rotary Converter.....	175
Power Required in Binderies.....	176
The Electric Lighting System of the Washington Union Sta- tion, Washington, D. C.....	177
Kokomo, Marion & Western Traction Co.....	182
An Exhaust Steam Turbine Plant.....	187

### SEPTEMBER

A Campaign of Education.....	191
Transformer Iron.....	192
Empire State Gas and Electrical Association.....	192
The Relation of Rates of Efficiency of Light-Sources.....	192
Artificial Lighting of Public Schools.....	193
High-Tension Switchboard Practice in America.....	194
A Remarkable Vacuum Pump.....	205
Overhead Lines.....	207
The Power Development of the Northern Colorado Power Company .....	213
Series Incandescent Systems with Tungsten Lamps.....	218
A Tungsten Diffusing Cluster.....	219
Trade Notes.....	220
Questions and Answers.....	221
Legal Notes.....	221
Clippings from Consular and Trade Reports.....	222

### OCTOBER

Silicon Steel.....	223
An Old Controversy.....	225
Electrical Shows.....	226
The New Haven Electrification.....	227
Allis-Chalmers Annual Report.....	228

	PAGE
Electric Exports.....	228
The Valuation of a Steam Power Plant.....	228
Overhead Construction.....	229
Impregnating Compounds.....	236
A New Business Problem.....	236
Switchboard Notes.....	237
Evolution of the Return Circuit Department.....	238
Measurements with Portable Instruments.....	239
New Plant for the Electric Cable Co.....	245
The New Westinghouse Lamp Works.....	246

### NOVEMBER

Permutators .....	247
The Westinghouse Reorganization.....	248
Output Costs of Small Plants.....	248
The Business Outlook.....	249
Safety Engine-Stops.....	249
The Permutator.....	250
Electric Furnaces.....	254
Current-Surge in Closing an Inductive Circuit.....	255
Electrical Work in India.....	257
Underground Construction.....	258
Comparative Cost of Various Street Illuminants.....	263
The Probable Effect of the Higher Efficiency Incandescent Lamps on Central Station Income.....	264
The Electric Fault-Finder.....	269
The Keokuk Accident.....	270

### DECEMBER

Some Causes of Variations in High-Tension Practice.....	271
Developments in Single-Phase Electrification.....	272
The Return Circuit.....	273
Output Costs of the Isolated Factory Plant.....	274
Austin Municipal Plant.....	274
Pennsylvania Terminal Electrification.....	274
Some Features of European High-Tension Practice.....	275
Tensile Strength of Trolley Wires.....	283
Suburban Electric Railway Return Circuits.....	285
On Protection from Lightning.....	289
Rushing a Telephone Switchboard to Paris.....	291

# THE ELECTRICAL AGE

Volume XXXIX. Number 1.  
\$1.00 a year; 15 cents a copy

New York, January, 1908

The Electrical Age Co  
New York and London

ESTABLISHED 1883

Published monthly by The Electrical Age Co., 45 E. 42d Street, New York.

J. H. SMITH, Pres. C. A. HOPE, Sec. and Treas.

Telephone No. 6498 38th. Private branch exchange connecting all departments.  
Cable Address—Revolvable, New York.

## SUBSCRIPTION RATES

United States and Mexico, \$1.00; Canada, \$1.50. To Other Countries, \$2.50

## NOTICE TO ADVERTISERS

Insertion of new advertisements or changes of copy cannot be guaranteed for the following issue if received later than the 15th of each month.

## LONDON OFFICES

Business and Editorial Departments, 33 Bedford Street  
Strand, W. C.

London Telephone, Post Office, 3807 Central. Private branch exchange. London Cable  
Address—Revolvable, London.

All remittances to London Office should be crossed London and County Banking Company.

## BRANCH OFFICES AND AGENCIES

Subscriptions may be sent to the following branch offices or agencies, where they will receive the same careful attention as at the home office in New York:

124, Queen St., Melbourne  
359, George St., Sydney  
61, Main St., Yokohama  
23, Esplanada Rd., Bombay

33, Loop St., Cape Town  
Unter den Linden, 5, Berlin  
Nevsky Prospect, St. Petersburg  
31, bis rue de Fauburg Montmartre, Paris

General Agents for United States and Canada: The American News Company

## Report of the Public Service Commission, Second District, New York.

In the first annual report of the Public Service Commission, Second District, New York, it is stated that the Commission will not consider applications of foreign gas and electric corporations to do business in New York. In a general way, it is the policy of the State to foster and encourage enterprises only where an enterprise appears commercially feasible and likely to return a fair income upon the necessary capital. Strict adherence to this policy will, in great measure, eliminate unprofitable enterprises from the money market and lessen very greatly the economical loss through the diversion of large amounts of capital in what would be otherwise unprofitable investments. Strict adherence to this policy will prevent also destructive competition and obviate the multiplication of facilities beyond the needs of the community. Such a policy pursued by the State of Ohio would have prevented the condition of affairs now prevalent at Toledo, where neither of the operating central stations have been able to pay dividends upon their investments.

The portion of the report dealing with the inspection of electric meters shows that the work of the Commission in this respect is farcical. Six tests of consumers' meters, upon complaint, have been made in six cases and the Commission stated, "after thorough investigation it is convinced that the tendency of electric meters is to under-register," though upon what grounds it arrives at this conclusion is not apparent. If such is the case, the central stations of New York are certainly entitled to adequate inspection in order to protect them against the losses from slow meters.

## Power-factor Rating of Generators

A large number of purchasers of electrical generators and other apparatus for industrial plants do not fully appreciate the importance of power-factor. In general, if they buy, say, a 500 k.w. generator to care for approximately 500 k.w. of induction motors (with some allowance for line loss) they think they have linked up properly.

It is not generally clear to them that an induction motor generously large for a given duty may, by running much underloaded for a large part of the time, raise the deuce with the output of their generator, not to speak of the exciter. The purchaser often makes two mistakes: first, by making a bad disposition of motors for a given service, or, in other words, a poor proportion of capacity to the average demand upon them; and, second, by buying the generator rated approximately at their aggregate power for 100 per cent. power-factor, and the exciter on the same basis.

Now this is not particularly reprehensible in many a purchaser, because he really does not know any better. If he had an advising engineer this difficulty would not arise, but he does not, and often would not, because he thinks that the manufacturer's engineer or salesman will see that he gets the proper apparatus.

When it is considered how much free educational work in electrical engineering is done by the agents of electrical manufacturers simply to foster the use of alternating-current apparatus, it would hardly be expected that any difficulty could arise over power-factor. But it does, and the situation usually develops as follows: To sell a machine for, say, 500 k.w., 80 per cent. power-factor is mighty hard sledding against a quotation on one rated at 500 k.w., 100 per cent. power-factor, since the lat-

ter is smaller and cheaper. The exciter quotations are likewise affected. Naturally, the purchaser is inclined to buy the cheaper machine since he well knows there is not much choice in the quality of apparatus. Even after the folly of purchasing a 100 per cent. power-factor rated machine for an 80 per cent. power-factor load is apparent, it is difficult to establish the real fact. For power-factor is an elusive thing, a sort of convenient bogey, which can be made to appear or disappear, and whose effects upon the generator may be attributed to heavy drop in the wiring to motors improperly sized to their work, or to numerous other conditions whose determination is expensive and whose cure is costly. Fortunately, the difficulty can be usually solved by the installation of a second machine. This remedy, however, is quite beside the question.

This condition will probably not change until the matter is passed upon by the standardization committee of the Institute, and in the interest of the entire industry it is to be hoped that the committee will provide for a kilowatt rating at some power-factor common in industrial work. It may be best to approach the matter by defining the regulation of the machine. However, it is not for us to point out the proper solution of the difficulty.

## The Tungsten Filament

One of the advantages of the tungsten lamp which is not generally understood lies in the number of folds of the filament on itself. If the lamp burns out, or the filament breaks, it is possible to shake the lamp so that one of the broken ends will catch on to a good section of the filament. When the lamp is turned into the socket again, the new filament contacts will fuse together, and the lamp

will continue to burn, though at an increased brilliancy due to the cutting out of a section of the filament. Recently a lamp which had burned out at 600 hours, was jiggered as described above and continued to burn 300 hours longer.

#### A New Storage Cell

A new type of storage battery having, with the same ampere-hour rating, about one-third the weight of a chloride accumulator, is being put on the market. The type of construction is radical. By the enclosure of the lead oxid in a brittle and fragile earthenware box, made by placing two reticulated clay plates together, it is hoped to hold in the active material and to prevent the usual shrinking during charge and discharge, as well as to avoid the common enough buckling of the Planté plates. The cell is known as the "Standard" accumulator.

The active material and its lead-electrode are inclosed in a thin box of unglazed clay. The inner surface of the box is reticulated partly to strengthen the clay box and partly to grip the active material, while the outer surface is ribbed vertically to strengthen the clay plate further, and to permit the free circulation of the electrolyte.

With a porous cell of this type it would be rather difficult to prevent infiltration of the active material and yet maintain a low internal resistance. This, it would appear, is altogether a matter of proper porosity, and to this problem, Mr. Clare, the inventor of the cell, formerly associated with the defunct Hatch Accumulator Co., of Boston, which had infringed the patents of the Electric Storage Battery Co., has brought twenty years of skill in clay working. It is believed by the inventor that this troublesome point has been overcome.

The elemental clay box, which has just been described, is about  $3\frac{1}{2}$  inches square and half an inch thick, including the lead plate. By the assembly of these unit boxes accumulators can be made of any capacity. While the boxes are of quite fragile material, yet their compact form should make it possible to build a cell structure having greater strength than the individual clay box. After the assembly of the clay boxes, the whole is enclosed in glass plates nicely fitted together by grinding and cemented together by paraffine. The use of the enclosed glass cell with its paraffine cementation is an essential element in this accumulator. As closely as can be ascertained, none of the cells are as yet in central station or industrial service, and it will re-

quire some time to establish beyond peradventure the durability of this type of construction. It is hardly likely to be employed in electric vehicles, owing to the jarring and jolting to which the earthenware cells would be subjected. None of the gentlemen financially interested in the company have, so far as can be ascertained, any experience in the electric field, except the inventor himself.

#### The Central Station Distributing System

The development of central-station distribution of electricity has been very rapid in recent years. Lower rates and increased advertising have brought about a condition, in some cases, which has required the best efforts of distributing engineers to keep up with the demands.

The increasing number of men engaged in such work and the almost infinite variety of problems presented makes this an opportune time for a discussion of the principles governing the design and extension of a distributing system.

The article in this issue entitled "Central-Station Distributing System" is the first of a series of articles covering this subject which will appear in THE ELECTRICAL AGE during the succeeding months. The principles of design and the limitations met in practice will be outlined concisely, and this will be followed by a discussion of the methods of construction, maintenance and operation which are current in American practice.

These articles will endeavor to cover the field in such a way as to be of service to the engineers in charge of small distributing systems, as well as those who are directing the development of distributing systems in the larger cities.

#### Personality

When you read the annual balance sheets of the great corporations of the country, do you imagine that the asset column really exhibits the most valuable and best money-making elements of the concern? Do the figures representing the value of the plant, the patents, the working capital or the volume of business done annually give a true conception of the actual prosperity of a concern? Is it possible from these figures to form a sound judgment as to whether the stock of a company ought to go up or down in price? Surely not. Truthful as may be the figures representing the money value of a business, they fail totally in giving an idea of the most important element necessary for the success of an industrial plant.

Personality is of more consequence to success than all the elements shown in the balance-sheet figures put together.

One dominant man who absolutely commands the respect of all who come into professional contact with him is a tower of strength to even the largest corporation, and with a corps of such men at the heads of departments any corporation can defy competition.

Perhaps no more remarkable instance of this tremendous influence can be cited than that of Edward Reynolds in the sale of the 96,000 h.p. engine equipment of the Manhattan power-station, New York. Could any other man in the world have sold 96,000 h.p. of engines of a size and type never before built upon the strength of nothing but his reputation and a plan hastily sketched upon the back of a visiting card?

That was what Mr. Reynolds did.

The Manhattan Railway Co. had arranged to replace its old steam locomotives by electric traction. The company had secured for its powerhouse the only available water site within the proper distance of its lines and figured that it needed 96,000 nominal horse power with perhaps a 50 per cent. overload capacity for short-load peaks.

There was no question about how much space would be absolutely required for boilers, and when this was figured out it was clear that if the necessary horse power in engines and generators were to be installed it would have to be done in a space much smaller than any such amount of prime movers had ever been gotten into before.

Many engineers of repute had been consulted about the design of the engines, but none had offered a satisfactory solution of the problem. Finally Mr. Reynolds was sent for. The summons was by wire, asking him to meet the board of directors in New York the following day.

Mr. Reynolds was in Milwaukee when the summons came. He started for New York at once. As a designer and builder of big steam engines Mr. Reynolds was known all over the world. Under his supervision the big engine of the Centennial Exposition in Philadelphia, in 1876, had been built at the Corliss works, where Mr. Reynolds worked his way up from the bench to the place of general manager. As chief engineer of the E. P. Allis works he had designed and built the big engine of the Columbia Exposition at Chicago in 1894. Whatever he took in hand he handled successfully. His word was a guarantee.

Mr. Reynolds started from Mil-



waukee. The story of the inception of the Manhattan type of engine, as he told it, is as follows:

"As I rode from Milwaukee to Chicago, I began to consider how to get 96,000 h.p. of engines and generators into the required space. I took a mental survey of every type of engine that had ever been built and considered them one by one. I saw that it was possible to use one of the accepted types of engines for the purpose, but in order to secure the constant turning moment necessary for the close regulation of electrical generators of this type it would require fly-wheels so heavy that no concern in

America could build shafts big enough to carry them.

"I had arrived at this conclusion when my train reached Chicago and I transferred to the New York train and again took the subject under consideration.

"I thought and thought about it until bed time, and finally turned into my berth without having arrived at any solution.

"As I lay in my berth there suddenly flashed into my mind a way to overcome the difficulty. I turned on the light in my berth, fished out a visiting card from my pocket, and with a lead pencil made a hasty sketch.

Then I turned over and went to sleep.

"With the pencil sketch to show what I proposed to build I went into the meeting of the board of directors the next day and took the order for the engines."

Mr. Reynolds built the Manhattan engines according to his original inspiration. They not only worked, but although the power-house was short two engines during the whole of the first year of its use it never had to shut down nor did the railroad company ever have to take off a train or restrict the service even during the most crowded rush hours.

## The Estimation of Power-Factor on Unbalanced Three-phase Loads

H. S. BAKER

THE following method has been found useful in the estimation of power-factor on unbalanced three-phase loads and also in checking series meter connections where other means are found unavailable.

Before going into explanations, a case will be worked out from readings actually taken.

Figure 1 shows wiring of feeder in hand. Voltages (a) to (b), (b) to (c) to (a) are found to be alike, hence the voltage vectors (a) to (b), (b) to (c) and (c) to (a) form an equilateral triangle. Had (a) to (c) measured 73 per cent. greater than (a) to (b), then there would have been a cross in the shunt connections.

The next step is to determine which e.m.f. is leading; (b) to (a), or (b) to (c).

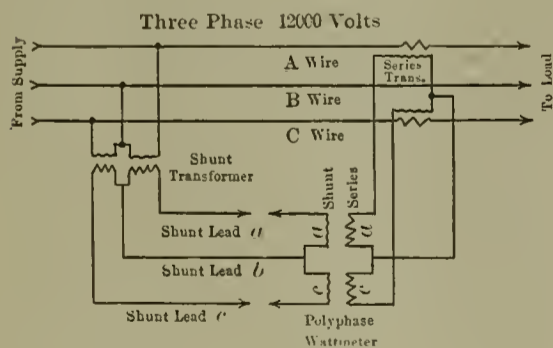

FIG. 1.

This determination is in most cases unnecessary because the complete vector diagram can be worked out first and it will then be apparent which rotation of diagram suits the nature of the load in question.

For this determination a Weston wattmeter (or any wattmeter whose shunt current is in step with its shunt e.m.f.), an incandescent lamp and a

spare wattmeter whose shunt circuit forms a good choke coil are used. The lamp is placed in series with the series coil of the wattmeter (see Fig. 2). The choke coil is placed in series with its shunt. The remaining ends of shunt and series are connected to shunt lead (b).

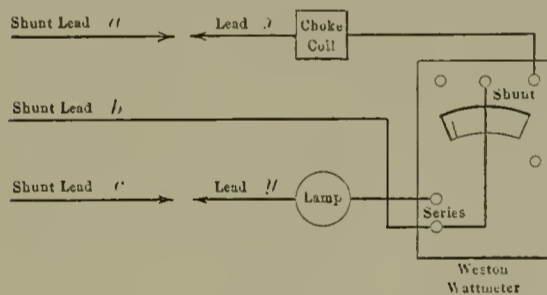

FIG. 2.

Then (x) is connected to (a) and (y) to (c) and the wattmeter reading is 22 watts. Then (x) is connected to (c) and (y) to (a) and the reading is 69 watts. This shows that the e.m.f. (b) to (a) lags behind the e.m.f. (b) to (c) because on the first reading of 22 watts the lamp load, being ohmic, gives the current to the series of wattmeter in step with e.m.f. (b) to (c), and the e.m.f. (b) to (a) lags that by 60 degrees, and the choke coil makes the shunt current lag still more, giving a very low power-factor leading current applied to the wattmeter, whereas on the second reading of 69 watts, the series current is in step with e.m.f. (b) to (a), and the e.m.f. (b) to (c) leads it by 60 degrees, and the choke coil makes the shunt current lag behind this 60-degree lead, giving a comparatively high power-factor applied to the wattmeter, and hence the higher

reading of the meter for the same volt-amperes on meter.

Now that we know that the e.m.f. (b) to (a) lags behind the e.m.f. (b) to (c) we can plot the e.m.f. triangle (a), (b), (c), accordingly as in Fig. 3, and the order in which the e.m.f.'s over neutral reach maximum is (a), (b), (c).

Returning to polyphase wattmeter Fig. 1, the load current is following in its series. Connect shunt lead (a) to shunt coil (a) and leave shunt coil (c) dead. The reading of meter is 500 kw. Now connect shunt lead (a)

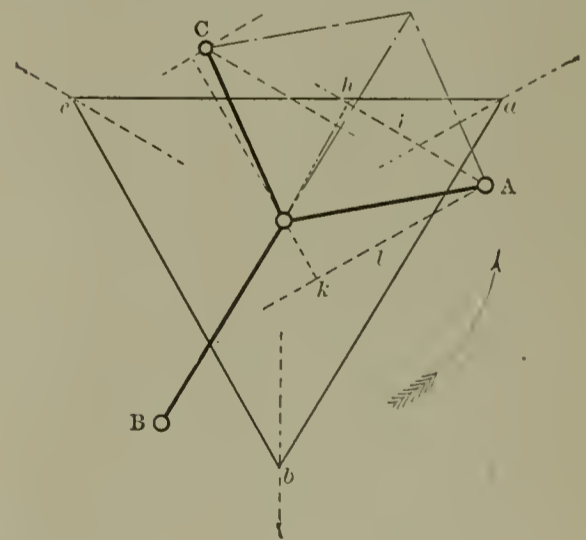

FIG. 3.

to shunt coil (c) and leave shunt coil (a) dead. The reading is 400 kw. Connect shunt lead (c) to shunt coil (c) and leave shunt coil (a) dead. The reading is 700 kw. Connect shunt lead (c) to shunt coil (a) and leave shunt coil (c) dead and the reading is minus 250 kw.

Construction.—In Fig. 3, starting from center of triangle measure a

distance parallel to direction of  $(ba)$ , of 500 kw., taking scale at 600 kw. equal one inch. From this point  $(h)$  draw a line  $(hi)$  perpendicular to direction of  $(ba)$ . Again starting from center of triangle measure parallel to direction of  $(bc)$  a distance of minus 250 kw. That is to say, measure 250 six-hundredths of an inch in direction parallel to  $(cb)$ , as shown to point  $(k)$ . Draw  $(ki)$  perpendicular to  $(bc)$ , and where  $(ki)$  intersects  $(hi)$  is the end of the current vector of the current in  $(A)$  wire of feeder. Similarly measure from center parallel to  $(bc)$  700 kw., and erect perpendicular. Measure 400 kw. from center parallel to  $(ba)$  and erect perpendicular. The intersection of these perpendiculars is the end point of current vector of current in  $(C)$  wire of feeder.

Now, if circuit is three-wire, three-phase, then complete the parallelogram of which the two current vectors are the two sides. Extend its diagonal through the center to an equal distance on other side of center, and the end of this is the end of the third current vector.

The lengths of the current vectors so plotted measure the actual amperes in the three wires, and the directions of these vectors relatively to lines drawn from the center of the triangle through its corners  $(a)$ ,  $(b)$  and  $(c)$  respectively show the angles of lag of the currents in the three corresponding wires.

Methods have been published for obtaining power-factor on balanced three-phase loads, by ratio of wattmeter readings, but these are rendered quite deceptive when used on unbalanced loads.

If the e.m.f. between wires is, say, 12,000 volts, then the scale of amperes on which the current vectors must be measured is  $600,000/12,000 = 50$  amperes per inch when kilowatt scale is 600 kw. per inch, or 600,000 watts per inch.

The correctness of the above method can be easily proved by showing that the current vector  $A$  is the only line whose component along the e.m.f.  $(b)$  to  $(a)$  is plus 500 kw., and at the same time whose component along  $(b)$  to  $(c)$  is minus 250 kw. Similarly with current vector  $(C)$ .

Now from the above kilowatt readings the total real kilowatt of the load is  $500+700=1200$  kw.

Applying these values to the old formula to give power-factor by ratio of wattmeter readings we have:  
Power-factor =

$$\frac{1+500/700}{2\sqrt{(500/700)^2-500/700+1}} = .96.$$

This corresponds to 16 degrees lag.

The diagram Fig. 3 shows the current in  $A$  to be 64 amperes, and to have a lag of 20 degrees; the current in  $B$  to be 75 amperes, and to have a lag of 30 degrees; the current in  $C$  to be 59 amperes and to have a lag of 35 degrees.

A method used for calculating power-factor in unbalanced three-phase circuits by a large electric manufacturing company is to divide the total real watts by the volts across lines times the average amperes per wire, times 1.73. This method applied to the above amperes and watts gives a power-factor of 87.3 per cent., which corresponds to a lag of 29 degrees.

The American Institute of Electrical Engineers gives a definition of power-factor as "ratio of real watts to the apparent watts." The apparent watts are the product of the volts and the amperes, when applied to a single-phase circuit. When applied to a two-phase circuit with balanced load, the amperes, or, more correctly speaking, the equivalent single-phase amperes, are twice the current in one wire, while the volts are the volts measured across one phase, or across opposite corners of the voltage square. In a three-phase circuit with balanced load, the equivalent single-phase amperes are 1.73 times the amperes in one wire, while the voltage is the voltage from wire to wire, or equal to one side of the e.m.f. triangle.

Now when we come to unbalanced three-phase loads the power-factor has been defined as the ratio of the total real watts to the apparent watts or (volt-amperes) where the amperes are 1.73 times the average current per wire, and the volts are the volts between wires.

Since it is the net wattless amperes that is the undesirable feature

of low power-factor, and as these wattless amperes are a very real quantity rather than an apparent quantity, why not define the power-factor in unbalanced three-phase circuits, or indeed in any circuit, by say the angle of lag or lead is the angle whose tangent is the algebraic sum of the wattless amperes divided by the algebraic sum of the working components of the currents (taking lagging wattless amperes as, say, plus and leading wattless amperes as minus).

It can be shown by geometry that the formula to give tangent of angle of lag (for balanced or unbalanced three-phase circuits) according to the above definition is:

$$\tan \phi = \frac{(W_a - W_c) - 2(W_{ac} - W_{ca})}{\sqrt{3}(W_a + W_c)}$$

Where  $W_a$  equals reading, using current  $A$  reacting on e.m.f.  $(b)$  to  $(a)$ .

$W_c$  equals reading, using current  $C$  reacting on e.m.f.  $(b)$  to  $(c)$ .

$W_{ac}$  equals reading, using current  $A$  reacting on e.m.f.  $(b)$  to  $(c)$ .

$W_{ca}$  equals reading, using current  $C$  reacting on e.m.f.  $(b)$  to  $(a)$ .

In the above case

$$W_a = +500 \text{ kw.}$$

$$W_c = +700 \text{ kw.}$$

$$W_{ac} = -250 \text{ kw.}$$

$$W_{ca} = +400 \text{ kw.}$$

Then

$$\tan \phi = +0.53$$

$$\phi = 28^\circ \text{ lag.}$$

$$\text{PF} = 88.3 \text{ per cent. lag.}$$

This checks pretty well with previous method and requires only wattmeter readings, which are much more reliable than alternating-current ammeter readings, especially on light loads. On specially unbalanced loads this formula gives much more reasonable results. Take the case of an incandescent lighting load across one phase of a three-wire three-phase circuit. This formula gives 100 per cent. power-factor while the previous method gives 86.6 per cent. As a further illustration, take similar lamp loads across two of the three phases we have 100 per cent. power-factor by the proposed formula, and the previous method gives 93 per cent.



# The Central Station Distributing System

## Feeder Calculations

H. B. GEAR

General Inspector, Commonwealth Edison Co.

IN the transmission of electricity over wires, energy is lost by dissipation as heat, in proportion to the square of the current and to the resistance of the circuit.

$$\text{Loss} = C^2 R \text{ watts,}$$

when C is in amperes and R in ohms.

As the current in a circuit carrying a given amount of power decreases with increase of working voltage, it is obvious that the designer has control of the energy loss on his circuits in two ways, viz., by varying the voltage at which current is delivered, and by varying the resistance of the circuit.

The voltage at which current is delivered to the patrons of a distributing system must, on account of risk to life and property, be comparatively low, *i.e.*, 100 to 250 volts. Current is delivered for power purposes at 500 volts, and in some cases at 2200 volts for large consumers, but these voltages are unsuitable for lighting and small power purposes.

These voltages being fixed by other considerations, the problem resolves itself into one of selecting the proper resistance, *i.e.*, the proper size of conductor for the load.

Copper being obtainable in quantities and having a low specific resistance, is used as a conductor for distributing systems exclusively. Aluminum has been used on transmission lines for some years, but is not suitable for general purposes, owing to the difficulty of making joints and taps.

The resistance of copper as determined by Mathiessen and adopted by the American Institute of Electrical Engineers in 1893 is 9.59 ohms per mil-foot at 0°C. That is, a wire of pure copper 1 ft. long and 1/1000 inch in diameter has a resistance of 9.59 ohms at the freezing point. Commercial copper is usually about 98 per cent. pure and for wire as used, the resistance per mil-foot is therefore about 9.68 ohms.

The resistance of copper increases as the temperature increases, at the rate indicated by the following formula:

$$R = 9.69 (1 + .00406 T)$$

in which T is the temperature in degrees centigrade.

At 15° Cent. (equivalent to 59°

Fahr.)  $R = 9.68 [1 + (.00406 \text{ by } 15)] = 10.27$ .

This represents a temperature common in distributing work overhead and underground in the temperate zone.

The resistance of one mil-foot at various temperature is given in the following table:

Deg. C	Deg. F.	R. per mil-foot
-20	-4	8.93
-10	14	9.31
0	32	9.68
5	41	9.88
10	50	10.07
15	59	10.27
20	68	10.40
25	77	10.65
30	86	10.85
35	95	11.05
40	104	11.24
45	113	11.44
50	122	11.63
55	131	11.83
60	140	12.02

The resistance of one foot of wire of one circular mil area being 10.27 at 59 degrees Fahr., the resistance of D feet would be 10.27 by D. Likewise the resistance of one foot of wire having M circular mils area would be 10.27/M.

Therefore the resistance of a wire D feet long of M circular mil. area is  $R = D \times 10.27/M$ .

By the law of Ohm the drop in voltage in a circuit carrying C amperes and having a resistance of R ohms is  $E = CR$ .

Since for copper wire  $R = D$  by 10.27/M the drop in voltage of D feet in copper wire of M circular mils area is  $E = CD \times 10.27/M$ .

If D is taken as the distance one way, the drop in a two-wire direct-current circuit is:

$$E = \frac{2 DC \times 10.27}{M} = \frac{DC \times 20.54}{M}$$

Or if it is desired to know what size wire will be required to carry a load of C amperes a distance of D feet at a drop of E volts

$$M = \frac{DC \times 20.54}{E}$$

To illustrate: 100 amperes is to be transmitted 200 feet at a drop of two volts, what size wire will be needed?

$$M = \frac{200 \times 100 \times 20.54}{2} = 205,400 \text{ C mils.}$$

By reference to the wire table it is found that this is nearly the area of 0000 B. & S. gauge wire, and this size would therefore be selected.

In many cases the problem consists in ascertaining what the drop will be in a certain feeder whose length and size are fixed. In such cases the resistance per 1000 feet may be used to good advantage as follows:

$$E = C \times D \times R$$

in which D is the number of thousands of feet and R the resistance per 1000 feet, or  $10.27 \times 1000/M$ .

A feeder of No. 0, 5000 feet long, is to carry 80 amperes. What will be the drop? The value of R for No. 0 wire is:

$$\frac{10.27 \times 1000}{105,500} = .0974 \text{ ohm.}$$

From the rule above  $E = 80 \times 5 \times .0974 = 38.9$  volts.

The value of resistance per 1000 feet of the various sizes of wire may be found in Table I.

When alternating current is transmitted, the foregoing rule for determining the drop in voltage is not applicable, since the variations of the magnetic field accompanying the alternations of the current produce "back pressure" in the circuit which exerts a choking effect on the impressed electromotive force. This is called the electromotive force of self-induction, or the inductive reactance. It varies with the size of wire and the distance between centers of the wire, being less for small separations and more for greater ones.

The drop in pressure in an alternating circuit is therefore composed of two elements: (a) the drop due to the resistance of the wire, which is proportional to the energy loss and is known as the *ohmic drop*, and (b) the drop due to the self-induction of the wires acting as a closed circuit, known as the *inductive drop*.

The ohmic drop is that which would occur in the circuit if it were carrying a direct current of the same volume.

The inductive drop, which is a quarter cycle behind the current, does not subtract directly from the impressed voltage as does the ohmic drop in a direct-current circuit.

These two components of voltage drop may be represented as the two

atus, which is represented by AB in Fig. 1.

The flow of alternating current in any piece of apparatus composed of coils having an appreciable inductive reactance is therefore governed by the ohmic resistance and the inductive

directly in watts. The product of current by voltage OB is known as the apparent power and is expressed in "volt-amperes." The ratio of the actual power to the apparent power is called the "power-factor." The volt-amperes put into a circuit may therefore be multiplied by the power-factor to obtain the actual power, where no wattmeter is available. The power-factor of induction motors varies from 50 per cent. or less at starting up to 85 per cent. or 90 per cent. at full load. Large motors have a higher power-factor than smaller ones of the same type.

In Fig. 1, OA being the power component of OB, the ratio of OA to OB is the "power-factor." Likewise AB being the inductive component, the ratio of AB to OB is known as the "inductance factor." The power-factor being cosine of the angle AOB, the inductance factor is the sine of this angle, and the inductance factor may thus be readily found by reference to a table of sines and cosines, if the power-factor is known.

In an electric light feeder the component of the drop due to the resistance of the conductor may be represented by OA, and the component of drop due to inductance by AB. In an overhead circuit AB varies as the distance between wires is varied. In underground cables the conductors are usually so close together that the effect of inductance is about half that in overhead wires strung from 12 to 18 inches apart.

The resultant OB for a given feeder is, however, not necessarily the net drop in voltage impressed at the far end of the feeder. This varies with the power factor of the load though the same current is carried on the feeder in each case. That is, if a certain load draws 100 amperes at 70 per cent. power-factor, and another load draws 100 amperes at 100 per cent. power-factor, at the same delivered pressure, the net drop will be greater with the 70 per cent. power-factor current than with the 100 per cent. power-factor current.

In Fig. 1, OA represents the ohmic and AB the inductive drop in a circuit of No. 0 wire strung 12 inches apart. Under this condition the ohmic component is nearly equal to the inductive. With wires larger than No. 0 the inductive component is greater than the ohmic. With smaller wires the ohmic component is the greater. The relative values for No. 6 wire are represented by OA and CD in Fig. 1.

Referring to Fig. 2, let the line OE represent the pressure delivered at the terminals of an induction motor. OR is the component of OE, which is doing useful work. ER is the wattless component of self-induction

TABLE I.

SIZE	AREA Circular Mils	BARE DIAMETER		POUNDS Per 1,000 Feet		OHMS per 1,000 Feet
		Solid	Stranded	Bare	Triple Braid W. P.	
14	4,106	.064		12.4	25	2.5266
12	6,530	.081		19.8	35	1.5890
10	10,353	.102		31.4	53	.9994
8	16,510	.125	.147	50.0	74	.6285
6	26,250	.162	.180	79.5	111	.3953
5	33,102	.182	.209	100.2	135	.3135
4	41,743	.204	.234	126.4	164	.2486
3	52,634	.229	.263	159.4	199	.1971
2	66,373	.258	.295	201.0	250	.1563
1	83,694	.289	.325	253.4	310	.1240
0	105,592	.325	.378	319.7	407	.0983
00	133,079	.365	.425	403.0	495	.0780
000	167,805	.410	.475	508.1	629	.0618
0000	211,600	.460	.524	640.7	767	.0490
250		.500	.568	576	920	.0428
300		.547	.637	908	1,041	.0356
350		.591	.680	1,059	1,231	.0305
400		.632	.735	1,211	1,420	.0262
450		.670	.770	1,362	1,628	.0237
500		.707	.820	1,514	1,856	.0214
600		.774	.900	1,816	2,197	.0178
750		.866	1,020	2,270	2,727	.0143
1,000		1.000	1.157	3,027	3,600	.0107
1,250		1.118	1.296	3,783		.0086
1,500		1.224	1.412	4,539		.0071
2,000		1.414	1.652	6,054		.0053

sides of a right-angled triangle of which the third side is the resultant.

The feeder circuit forms a closed loop through which all the lines of force of the magnetic field are linked. In a similar manner, the windings of motors, arc lamp coils, solenoids are linked with the magnetic field set up by their current flow. The field of force in such apparatus is, however, many times stronger than that of the feeder circuit, owing to the use of iron cores which have a very low resistance to the passage of magnetic flux. The use of a considerable number of turns in the winding, combined with the stronger magnetic field with a given current strength, causes all such apparatus to have a high inductive reactance.

When an alternating voltage is applied to such devices the flow of current, at the instant the circuit is closed, is proportional to the resistance of its windings and the pressure applied. As the pressure is changing from instant to instant, the current tends to follow the variation of the pressure. This change of current strength results in a change in the strength of the magnetic field, and this in turn induces an electromotive force in the windings of the appar-

reactance, and in the case of motors, transformers and arc lamps by the counter electromotive force, which represents the useful work being performed by the apparatus.

The inductive reactance set up by the current which flows under the influence of the impressed pressure is not directly opposed to the impressed

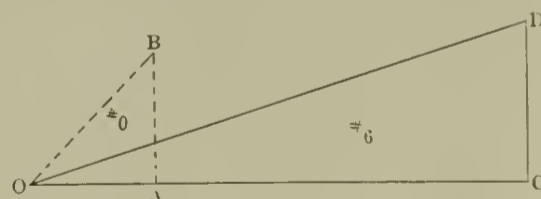

FIG. 1.

pressure as are the resistance and counter electromotive force, but is represented by the line AB at right angles to OA, the electromotive force doing work.

The impressed pressure on the apparatus is OB, and the current in the apparatus is out of phase with the impressed pressure by the angle AOB. The power in the apparatus is proportional to the product of the current by OA and not by OB, as it would be in a non-inductive circuit.

A wattmeter may be used to measure the power put into the circuit

which causes the current in the motor to be out of phase with the impressed voltage.

EL is the ohmic loss in the line, and LP is the inductive component of the line drop. The ohmic component of the line drop EL and the power component of the impressed voltage are in phase and therefore add directly. Similarly ER and LP are added. The

resultant OP is the bus pressure necessary to deliver a pressure OE at the motor terminals. The drop is therefore the difference between OP and OE.

With non-inductive load, such as incandescent lamps, ER disappears and the impressed pressure on the lamps takes the position OF (=OE). The generated pressure necessary to

deliver OF at the lamps is ON and the drop is the difference between ON and OF.

The power-factor being the cosine of the angle EOR, and the inductance factor being the sine of the same

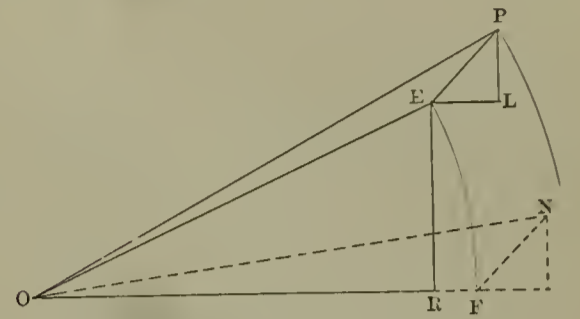

FIG. 2.

TABLE II.

Angle.....	0	10	20	30	40	45	50	60	70	80	90	Degrees
P. F. ....	100	98.4	93.9	86.6	76.6	70.7	64.3	50.	34.2	17.3	0	Per cent.
Ind. F. ....	0	17.3	34.2	50.	64.3	70.7	76.6	86.6	93.9	98.4	100	Per cent.

TABLE III.

By means of the table calculate the *Resistance-Volts* and the *Reactance-Volts* in the line, and find what per cent each is of the e.m.f. delivered at the end of the line. Starting from the point on the chart where the vertical line corresponding with power-factor of the load intersects the smallest circle, lay off in per cent the resistance e.m.f. horizontally and to the right; from the point thus obtained lay off upward in per cent the reactance-e.m.f. The circle on which the last point falls gives the drop in per cent of the e.m.f. delivered at the end of the line. Every tenth circle arc is marked with the per cent drop to which it corresponds.

Size of Wire B. & S.	Upper figures are Weight in Lbs. per 1000 ft. Single Wire	Upper figures are RESISTANCE-VOLTS in 1000 ft. of Line (2000 ft of wire) for One Ampere.	Throughout the table the lower figures give values for ONE MILE of line corresponding to those of the upper figures for 1000 feet of line.											
			Upper figures are REACTANCE-VOLTS in 1000 ft. of Line (-2000 ft. of Wire) for One Ampere at 7200 Alternations per Minute (60 Cycles per Second) for the distance given between Centers of Conductors.											
			1/2"	1"	2"	3"	6"	9"	12"	18"	24"	30"	36"	
0000	639	.098	.046	.079	.111	.130	.161	.180	.193	.212	.225	.235	.244	
	3376	.518	.243	.417	.586	.687	.850	.951	1.02	1.12	1.19	1.24	1.29	
000	507	.124	.052	.085	.116	.135	.167	.185	.199	.217	.230	.241	.249	
	2677	.653	.275	.449	.613	.713	.882	.977	1.05	1.15	1.22	1.27	1.32	
00	402	.156	.057	.090	.121	.140	.172	.190	.204	.222	.236	.246	.254	
	2123	.824	.301	.475	.639	.739	.908	1.00	1.08	1.17	1.25	1.30	1.34	
0	319	.197	.063	.095	.127	.145	.177	.196	.209	.228	.241	.251	.259	
	1685	1.04	.332	.502	.671	.766	.935	1.04	1.10	1.20	1.27	1.33	1.37	
1	253	.248	.068	.101	.132	.151	.183	.201	.214	.233	.246	.256	.265	
	1335	1.31	.359	.533	.687	.797	.966	1.06	1.13	1.23	1.30	1.35	1.40	
2	201	.313	.074	.106	.138	.156	.188	.206	.220	.238	.252	.262	.270	
	1059	1.65	.391	.560	.728	.824	.993	1.09	1.16	1.26	1.33	1.38	1.43	
3	159	.394	.079	.112	.143	.162	.193	.212	.225	.244	.257	.267	.275	
	840	2.08	.417	.591	.755	.856	1.02	1.12	1.19	1.29	1.36	1.41	1.45	
4	126	.497	.085	.117	.149	.167	.199	.217	.230	.249	.262	.272	.281	
	666	2.63	.449	.618	.787	.882	1.05	1.15	1.22	1.32	1.38	1.44	1.48	
5	100	.627	.090	.121	.154	.172	.204	.223	.236	.254	.268	.278	.286	
	528	3.31	.475	.639	.813	.908	1.08	1.18	1.25	1.34	1.42	1.47	1.51	
6	79	.791	.095	.127	.158	.178	.209	.228	.241	.260	.272	.283	.291	
	419	4.18	.502	.671	.834	.940	1.10	1.20	1.27	1.37	1.44	1.49	1.54	
7	63	.997	.101	.132	.164	.183	.214	.233	.246	.265	.278	.288	.296	
	332	5.27	.533	.697	.866	.966	1.13	1.23	1.30	1.40	1.47	1.52	1.56	
8	50	1.260	.106	.138	.169	.188	.220	.238	.252	.270	.284	.293	.302	
	263	6.64	.560	.729	.893	.993	1.16	1.26	1.33	1.43	1.50	1.55	1.60	

TABLE FOR CALCULATING THE DROP IN ALTERNATING-CURRENT LINES

angle, the inductance factor may be readily found in any case when the power-factor is known by reference to a table of sines and cosines. For convenient reference such a table of corresponding power and induction factors is provided herewith in Table II. The reactance and resistance of the ordinary sizes of wire, at various separations, are contained in Table III.

To illustrate: assume an induction motor load of 100 amperes at 2200 volts single-phase delivered at the end of a line of No. 0 wire 4500 feet long with wires 12 inches apart, a frequency of 60 and a power-factor of 80 per cent. The power-factor of the load being 80 per cent., we find by reference to Table II that the inductance factor is 60 per cent.

OR is therefore  $.80 \times 2200 = 1760$  volts.  
ER is therefore  $.6 \times 2200 = 1320$  volts,

By reference to Table III, we find that the ohmic loss per 1000 feet per ampere for No. 0 is .2 ohm. Hence EL is  $.2 \times 4.5 \times 100 = 90$  volts.

Similarly, the inductive drop per 1000 feet per ampere for 12-inch centers being .22, LP is  $.22 \times 4.5 \times 100 = 99$  volts per wire.

OR + EL is  $1760 + 90 = 1850$  volts.

ER + LP is  $1320 + 99 = 1419$  volts.

The resultant of these, OP, is

$$\sqrt{(1850)^2 + (1419)^2} = 2332 \text{ volts.}$$

This is the pressure necessary to deliver 2200 volts at the end of the line. The drop is therefore the difference or 132 volts, with a load of  $2200 \times 100 \times .8 = 176,000$  watts.

If a lighting load of 100 amperes at 100 per cent. power-factor were being carried, the inductance factor ER becomes zero and ON is

$$\sqrt{(2200)^2 + (99)^2} = 2202 \text{ volts.}$$

The drop is therefore 92 volts, with a load of  $2200 \times 100 \times 1 = 220,000$  watts.

If the line were a three-phase three-wire line, carrying 100 amperes per wire of motor load, the values of EL and LP would be multiplied by .866.

The bus pressure would be

$$OP = \sqrt{(1838)^2 + (1406)^2} = 2314 \text{ volts.}$$

The drop would therefore be 114 volts instead of 132, as on the single-phase motor line, with a load of  $3 \times 2200 \times 100 \times .577 \times .8 = 304,500$  watts.

In a four-wire three-phase system with 2200 volts from phase to neutral, the drop is one-half that on a single-phase feeder carrying the same current.

Mershon has devised a diagram by which the long calculations of the pressures involved in problems which are to be solved by the method of Fig. 2 are avoided and the result obtained with very little effort and with sufficient accuracy for all ordinary purposes.

This diagram is presented in Fig. 3. The concentric circles are drawn from a center off the page which corresponds to the point o in Fig. 2. In order to make the diagram applicable to any voltage, the rectangular divisions are divided into percentages. In the case used as an example in the foregoing the drop would be determined thus:

From Table III the ohmic loss 90 volts, 4.1 per cent., and the inductive loss 99.0 volts, 4.5 per cent., is first ascertained. The intersection of the .8 power-factor ordinate and the inner circle corresponds to the point R in Fig. 2. Beginning at this point pass to the right four divisions, and thence vertically upward  $4\frac{1}{2}$  divisions. The point thus reached corresponds to the point P in Fig. 2. The circle which passes nearest this point is the six per cent. circle. The drop is therefore 6.0 per cent. of 2200 volts, or 132 volts.

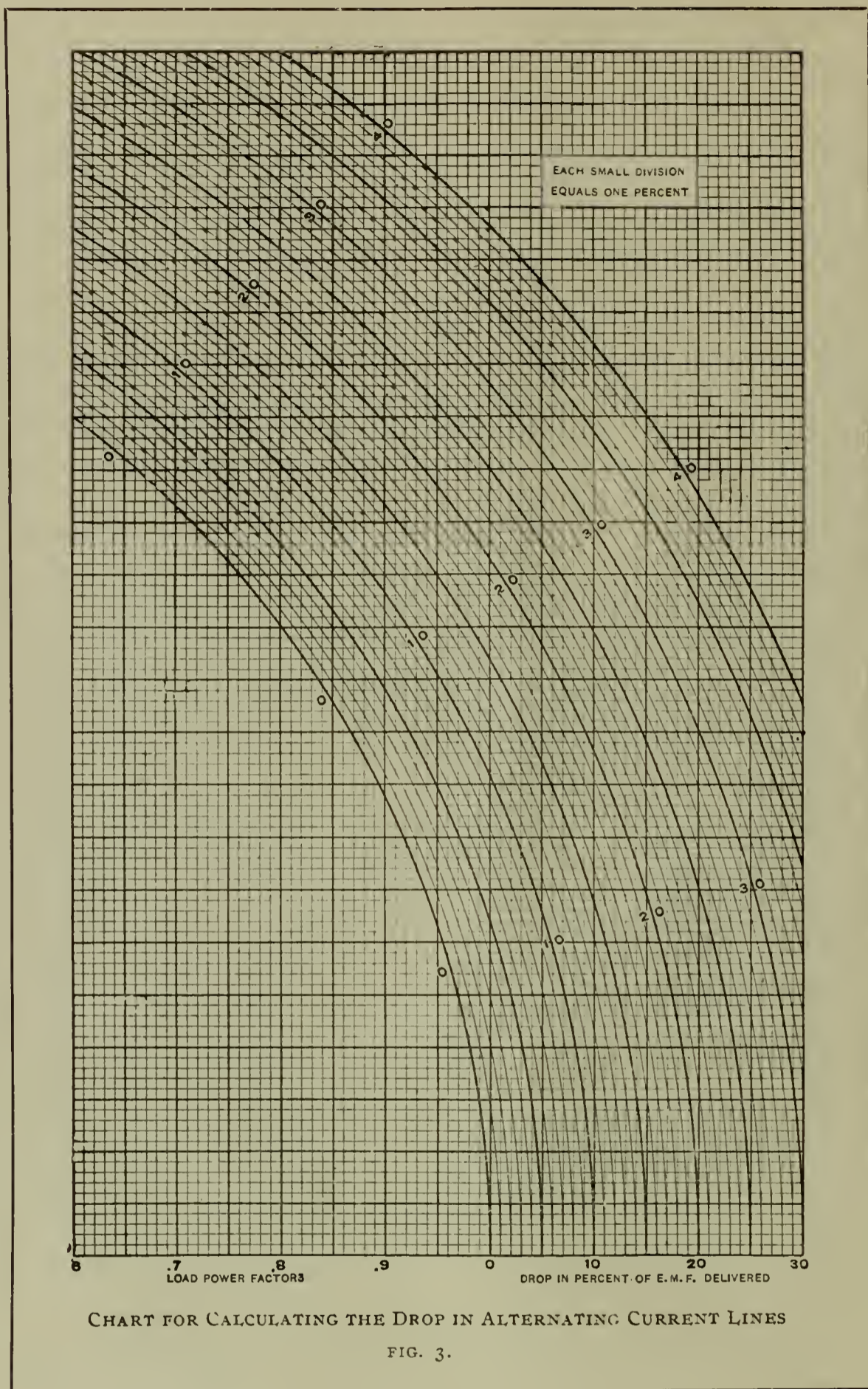

# Modern Arc Lighting

WILLIAM A. DEL MAR

THE arc light, having once established its supremacy as a street illuminant, made little progress for many years. The invention of the Welsbach gas mantle, by restoring to the gas light much of its old-time prestige, has given an impulse to the arc light which has not only made it overtake the gas mantle, but has placed it in a position of greater supremacy than ever.

The theory of the arc light has similarly undergone a transformation which may well surprise those who have not closely followed its evolution.

An account of modern ideas and modern practice is given below:

## NATURE OF THE ARC.

An electric arc is the passage of current between two terminals through a conducting vapor bridge consisting of the material of the negative terminal, issuing from the negative.

The electric spark, on the other hand, is merely the passage of current between terminals through the medium of the gas or vapor filling the space.

## STARTING THE ARC.

The spark will pass as soon as there is a sufficient voltage, because the conducting medium is there. The arc cannot pass without first establishing the bridge of conducting vapor from the negative to the positive. This requires the expenditure of energy for the latent heat of evaporation, kinetic energy of motion of the vapor stream, etc., and this energy must be expended before the arc can exist. Before the current flows, no energy can be expended by the electric circuit, and therefore it follows that the electric arc by the law of conservation of energy cannot spontaneously start, but must be started.

## METHODS OF STARTING ARCS.

(1) Bring the conductors in metallic contact with each other, and then, the circuit being established, separate them, the current flowing and the energy required to produce the vapor bridge being derived from the electrical energy of the current. This method is used in arc lamps.

(2) Raise the potential across the terminals so high that the energy of the electrostatic field between the

terminals is sufficient to produce the vapor bridge.

(3) Supply the vapor bridge from a subsidiary arc. This is made use of in the mercury arc rectifier.

## THE CARBON ARC.

Until very recently the only arc used for illumination was the arc between carbon electrodes, though at the present time there are several materials used, such as magnetite, mercury, and mixtures of various substances with carbon.

## THE CRATER.

The vapor column of the carbon arc impinging on the positive electrode raises the end of the latter to a very high temperature and volatilizes the carbon. The effect of this is to cause a hollow to be burned in the tip of the positive electrode. This hollow is called the crater.

## SOURCES OF LUMINOSITY.

The light of the arc is derived from the vapor column or from a body heated to incandescence by the vapor column.

In the old carbon electrode arc no special effort was made to raise the luminosity of the vapor column, the incandescent spot or crater on the positive carbon being relied upon for practically the entire light. For this reason the positive carbon was always placed above the negative in order that the crater might better shed its light downward.

It is not improbable that in the near future lamps will be developed with luminous vapor columns impinging on positive electrodes of high luminosity.

## DATA REGARDING ARC LAMPS.

The following tables give data regarding arc lamps of various types for direct and alternating current circuits. Among the important items are the watts per candle-power at 110 volts, and the length of carbons used per hour. These lamps are comparable in efficiency of distributing the electric energy, the watts per candle-power at 110 volts being a true measure of the lamp efficiency. The column headed carbons used per hour is of value, since for any allowable length of carbon the interval between trims is definitely fixed.

## HISSING.

When the crater is surrounded by the hot gases constituting the arc, the arc is silent, but if the crater flows over the tip of the carbon and comes into contact with cool air, a peculiar hissing sound is evolved.

## THE ENCLOSED ARC.

A carbon arc enclosed in a glass globe runs much longer than an open arc, owing to the slower consumption of the carbons. The color of the enclosed arc is usually pale violet and is disliked by the public.

While it is possible to run an enclosed arc so as to give a good color, it is usually found desirable to

## CONTINUOUS CURRENT ARCS.

Type of Lamp.	Amps.	Volts.	Watts		Mean Hemispherical intensity.	Watts per candle-power		Carbons used per hour. m.m.
			Useful.	Total.		Absolute.	At 110 Volts.	
Ordinary Carbons.....	9	40	360	495	700	.514	.710	14-16
Ordinary Carbons (3 in series).....	9	35	315	330	540	.583	.730	14-16
Flame Arc, vertical cored carbons.....	9	40	360	495	910	.396	.610	27.5
Intensive flame arc, inclined cored carbons...	9	45	405	495	2,000	.202	.247	34-425
Enclosed arc (American).....	6.8	70	476	768	329	1.45	2.334	1.5-2
Magnetite arc.....	3.5	91	320	385	400	.80	.962	1-2
Bremer Lamp (9-amp.).....	9	48	412	495	4,814	.131	.143	35-45
Carbo-mineral lamp (9-amp.).....	9.1	43	391.3	500	4,800	.081	.103	16-20
Carbo-mineral lamp (5-amp.).....	5.12	51.6	241.2	282	2,210	.109	.128	16-20
Carbo-mineral lamp (3-amp.).....	3.5	80	171.5	165	1,339	.128	.124	18-20
Mercury arc.....	3.5	80	280	385	770	.362	.50	—
Terro-titanium arc.....	3.5	483	169	385	700	.242	.55	1-2
Carbone Luminous arc.....	10	90	900	1100	1,070	.82	.98	18-20

The flame arc, unlike the arc described above, owes the greater part of its luminosity to the vapor column and very little or none to the heat of the positive electrode.

lengthen the arc, so that it will run directly off the 110 or 125 volt mains. It is the abnormally long arc which has the disagreeable violet color. Open arcs cannot be run at high volt-

age, owing to the crater on the positive carbon overflowing and being cooled by the air when the voltage is raised considerably. For this reason

the negative carbon, being wide and flat, cuts off much of the light from the crater, and makes this type of arc less efficient than the open arc.

arc is unstable and hisses. The hissing period is indicated by the dotted line in Fig. 1.

The hissing point being absent in enclosed arcs, the curve for such arcs is quite continuous.

ALTERNATING CURRENT ARCS.

Type of Lamp.	Amps.	Volts.	Watts		Mean Hemispherical Intensity	Watts per candle-power		Carbons used per hour m.m.
			Useful	Total		Absolute	At 110 Volts.	
Ordinary carbons.....	9	30	270	330	350	.772	.945	15-16
Ordinary cored carbons.....	15	35	480	555	470	1.02	1.18	15-16
Flame arc, vertical carbons.....	9	30	270	330	700	.386	.471	30
Flame arc, inclined carbons.....	9	45	405	495	2,000	.202	.247	35-45
Enclosed arc.....	6.6	70	482	726	314	1.535	2.312	1-2
Bremer lamp.....	9	48	.....	.....	.....	.131	.143	35-45
Carbo-mineral lamp.....	10	35	255	370	1,890	.135	.174	15-20
Carbo-mineral lamp (3 in series).....	8	33	225	272	1,000	.225	.272	15-20

[Both of above tables from Blondell, Soc. Int. Elect. Bull. 7, pp. 137-169, March, and pp. 267-286, April, 1907.]

open arcs cannot have the violet color characteristic of a long arc.

INFLUENCE OF AIR SPACE ON LIFE OF CARBONS.

A series of tests made with different clearances between carbons and with different cap openings show the total consumption of carbons to vary with the air space.

II.II MM. CARBONS, 8 AMPERES.

Test Number	Diam. of top Opening m.m.	Clearance m.m.	Positive Carbon	Negative Carbon
			m.m. per hour	m.m. per hour
1	11.15	.04	2.2	.1
2	11.9	.8	2.0	.3
3	12.7	1.6	1.9	.4
4	14.3	3.2	2.3	.4
5	17.5	6.4	2.8	.5
6	28.6	17.1	11.5	.8

INFLUENCE OF POSITION OF ARC IN GLOBE ON LIFE OF CARBONS.

The consumption of carbon is least when the arc is near the top of the glass, i.e., near the opening, and greatest when the arc is at the bottom of the glass.

EFFICIENCY OF ENCLOSED ARC.

The current being small and the arc long, the carbons burn flat. Hence

This is best shown by a series of tests made on a well-known make of enclosed arc lamp in which the photometric measurements were made at different angles from the horizontal.

The candle-power (C. P.) was taken by Ayrton's method, using red and green glasses separately to analyze the light.

CHARACTERISTICS OF SOLID CARBON ARC.

A peculiarity of the solid carbon arc is that with any particular length of arc, if the current be increased, the difference of potentials across the carbons will be decreased.

This occurs continuously until a

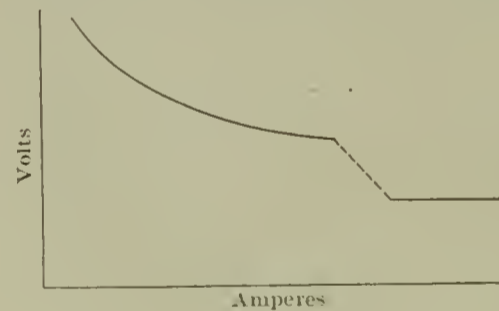

FIG. 1.

certain point, when in the open arc the current drops quite suddenly.

If the voltage is still increased the current will again become steady at a much lower value. Between the values before and after the drop, the

STEADYING RESISTANCE.

In any circuit an increase of e.m.f. must produce an increase of current. Hence, as the arc characteristic shows a decrease of current with increasing e.m.f. there must be placed in circuit with the arc a resistance great enough

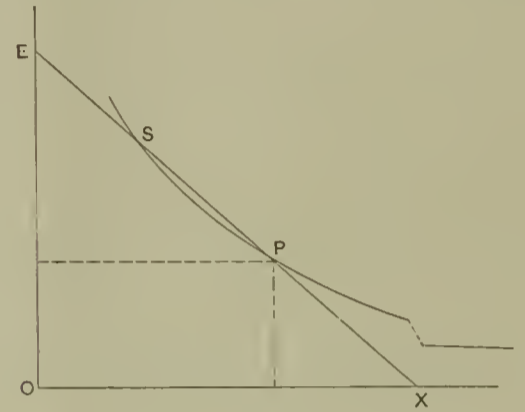

FIG. 2.

to compensate for this tendency if the arc is to be kept in a stable condition. The method of calculating this resistance is given below:

- e=OE=generator terminal volts.
- v=arc terminal volts.
- a=resistance (apparent) of arc.
- x=resistance in circuit, exclusive of arc and generator resistance.
- i=current, amperes.

$$(1) \frac{v}{i} = a$$

$$(2) \frac{e}{i} = a + x$$

$$(3) v = ia$$

$$(4) e = ia + ix$$

$$(5) e = v + ix$$

$$e - v$$

$$(6) \frac{e - v}{i} = x$$

On the arc characteristic (Fig. 2), find the point P corresponding to coordinate v and i, and set off OE=e along the vertical axis. Then join EP and continue EP until it cuts the horizontal axis at x.

If EX cuts the curve not only at P, but at S, above P, it would appear that the e.m.f., e could support either of two arcs. The point S, although affording a mathematical solution, is not physically possible, as it would involve an increase of e.m.f. producing a decrease of current, as may be seen by moving EX upward, parallel to its original position. Hence the arc corresponding to P is the only one possible.

TEST OF JANDUS ENCLOSED ARC.

	Angle down from Horizontal					
	0°	10°	20°	30°	40°	50°
Amperes.....	6.1	6.3	6.12	6.25	6.32	6.3
Volts across lamp.....	100.7	100	100.8	99.8	99.4	99.5
Total Watts.....	615	630	617	623	627	626
Watts lost in resistance.....	155	165	156	162	166	165
Watts taken by arc.....	460	465	461	461	461	461
Volts drop in resistance.....	25.4	26.5	25.5	26.0	26.3	26.25
Volts across arc.....	75.3	73.75	75.3	73.8	73.1	73.25
Green C. P., both globes on.....	670	915	900	875	1,040	1,060
Red C. P., both globes on.....	170	248	260	265	295	230
Green C. P., naked arc.....	1,035	1,510	1,525	1,560	1,810	1,935
Red C. P., naked arc.....	263	410	440	475	515	435
Total absorption by globes.....	35.3%	39.4%	41%	44%	42.5%	45%
Absorption by inner globe.....	10%	16%	18%	22%	20%	23.5%



If EX cuts the curve not only at P, but at some point, say, T, below P, the same reasoning shows the arc at P to be unstable, while that at T is stable.

Hence for any point P, the arc is stable only if the line EX does not cut the curve below P, and, therefore, if the resistance  $x$  be calculated so that EX is tangent to the curve,  $x$  or any greater resistance will steady the arc.

GENERATOR E.M.F. AND HISSING CURRENT.

E=generator e.m.f.

V=potential difference between carbons just before current is increased to hissing point.

A=max. amperes, which will not produce hissing.

D=drop in volts from silent to hissing.

R=rise of current from silent to hissing.

D

$E = V + A - \frac{D}{R}$

Thus, if the generator e.m.f. is great, and therefore the steadying resistance great, the rise of current at hissing will be less than when the e.m.f. is small.

VARIATION OF CANDLE-POWER WITH SIZE OF CARBONS.

The increase of candle-power with reduction in size of carbons is well illustrated by the following table. It will be noted that the candle-power can be greatly increased by reducing the size of the carbons, this increase being obtained without the expenditure of an additional amount of electric energy. The consumption of the carbons is more rapid with small car-

bons than with those of normal size, so that it is not desirable to reduce the size of carbons without regard to the cost of trimming.

Carbon is the principal source of light in the ordinary carbon arc, the bulk of the light from a chemical carbon arc emanates from the flame, and is apparently due to minute burning particles in the flame, which are raised to a very high state of incandescence. It has been found that the relative brilliancy of the flame of a chemical carbon lamp is about one-third that of the positive and negative craters. It must be remembered, however, that the area of the flame visible at any angle is many times that of the crater, and the total light emitted by the flame is consequently many times that emitted by the craters.

"The carbons are usually of the composite type, consisting of three zones. The outer zone, or envelope, is composed of pure carbon, giving mechanical strength. The next contains carbon mixed with various salts, such as those of calcium and magnesium and the inner soft centering core is made of the same materials less strongly compressed.

"The carbons are alongside of one another, instead of being coaxial, and are inclined, so as to bring their tips

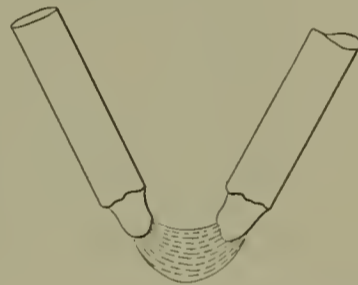

FIG. 3.—FLAMING ARC WITH INCLINED CARBONS.

near and pointing downward, the craters being so located that the carbons do not obstruct any of the light. "Being free from shadow, the

siderably more costly than pure carbons, and as the globes cannot be entirely enclosed, the life of the carbons is very short. Owing to its yellow color, the chemical carbon arc is useless where discrimination of colors is required, but for the illumination of the outsides of public buildings, theaters, etc., there is no light so pleasing.

"These arcs work on direct or alternating-current circuits, their superiority over the ordinary alternating-current arc being especially noticeable on account of the decreased flickerings at low frequencies, and the gain in efficiency due to the two craters pointing downward—the positive crater being concealed during half of every cycle in an ordinary arc. Taking the mean of the results given by different authorities, the efficiency of the chemical carbon arc is about 5.8 candles per watt."

If the two carbons are placed, as usual, one above the other, the light is very unsteady, due to the rising and whirling of the vapors; moreover, slags form on the upper carbon and drop on the lower carbon, tending to extinguish the arc.

The salts usually employed are calcium fluoride and other similar fluorides.

VOGEL FLAME ARC.

(Mr. Gaster, *Inst. Elect. Eng.*, May, 1906.)

The essential feature of the lamp is that the lower carbon stands in mercury amalgam, and when the lamp is switched on a luminous arc is at once formed, which heats the lower carbon and evaporates the mercury. The evaporation requires only a few seconds, and increases the luminous arc and the intensity of the light, as the radiant light of the hot mercury vapor is added to the light of the arc.

As the mercury vapor, together with the luminous arc, are enclosed in a glass globe, the vapor cannot escape, and when condensed on the walls of the globe is returned to the general reservoir.

The lamp will burn for 1200 to 1600 hours with a single pair of carbons and yields an intense light from 300 to 30,000 c. p. at a consumption of .2 to .4 watts per candle. The inventor gives for a lamp consuming 12 amperes at 50 volts and using 14 mm. carbons, an hourly consumption of .25 mm. for the positive electrode and .1 mm. for the negative electrode.

"EXCELLO" FLAME ARC.

Watts per mean hemispherical c. p.=.299; Amps.=8.7; volts across arc=44; m. h. c. p.=1352; diam. of carbons, 9 mm. positive and 8 mm. negative.

*Electrician*, April 7, 1905.

80 VOLTS—3.5 AMPERES.

Angle Degrees	Size of Carbons (Inches)						
	1/2	5/8	3/4	7/8	1/4	1/8	1/8
30	77	97	77	121	65	140	155.5
15	51	64	71	95	95.3	159	190
0	86	99	73	99	96	165	229
15	149	151	177	185.5	175	249	322
30	291	292	299	310	306.5	401	431
45	196	322	351	394	378	485	554
60	182	212	240	323	343	484	555
75	50	105	116	144	208	387	498
90	50	90	25	25	37	56	66

[G. N. Eastman (*Elect. World and Eng.*, April 15, 1905.)]

bons than with those of normal size, so that it is not desirable to reduce the size of carbons without regard to the cost of trimming.

CHEMICAL CARBON ARCS.

(Abstracted from paper by L. Andrews, *Inst. Elec. Eng.*, Aug., 1906.)

"Whereas, the crater on the posi-

opalenscent globe of a flame arc looks like a globe full of light. There is a certain amount of flickering, which is, however, not unpleasant for outdoor illumination. The fumes given off by the burning chemicals make the lamp unsuitable for use in a room not efficiently ventilated.

"The carbons are at present con-

## MAGNETITE ARC.

One of electrodes consists of black oxide of iron mixed with salts of chromium, titanium, etc. The positive electrode is copper.

The color is very close to daylight, and carbons run from 150 to 200 hours for one trimming. Efficiency more than .5 watts per candle.

The positive electrode is made so massive that it conducts away most of the heat from the arc and does not become very hot, thus forming a permanent part of the lamp.

The negative electrode burns at the rate of about  $\frac{1}{8}$  inch per hour.

All the light comes from the column of vapor, which is from  $\frac{3}{4}$  to  $1\frac{1}{8}$  inch long. During burning a fine smoke is given off, which is conveyed away by a chimney; the lamp is therefore not suited at present for indoor work.

## TITANIUM FLAME ARC.

An arc light is now being developed on the lines of the magnetite arc, titanium oxide being, however, used in the negative electrode. This being the most luminous substance known, promises to give a light of very high efficiency.

## CARBON ARC LAMP.

This is a long-flame arc with inclined carbons, the peculiarity of which is the magnetic control of the arc, which makes the light far steadier than that of the chemical carbon arcs. The color of the light very closely resembles that of daylight.

## ACTINIC ARC.

An arc with abnormal actinic power for photographic work may, according to A. Kufferrath, be prepared by impregnating the carbons with a mixture composed of equal parts of yttrium and lead nitrates.

## MERCURY VAPOR ARC.

(P. Cooper Hewitt Lamp.)

The mercury vapor lamp consists of a glass tube exhausted of air and containing a small quantity of mercury. This mercury is connected by platinum leading in wires to the negative main, and a platinum electrode at the opposite end of the tube to the positive main. When the arc or vapor column is established, the mercury boils and is recondensed and used over and over again.

The color of the arc is an intense yellowish green, which renders the

lamp useless for general illumination. It is, however, finding great favor for out-of-door illumination, especially in parks and grounds abounding in green foliage, and is also largely used for factory and workshop illumination and for photographic work

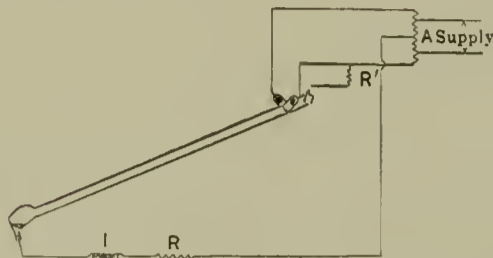

FIG. 4.

## STRIKING THE ARC.

As in the carbon arc light, this is accomplished by having two electrodes which, when brought together, establish a current which supplies the energy necessary to build up the vapor bridge or arc. The electrodes usually consist of mercury, and are brought

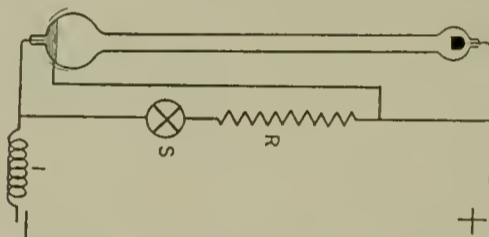

FIG. 5.—COOPER-HEWITT LAMP FOR DIRECT CURRENT.

together either by tilting the container or moving suitable parts from outside by a magnet.

Starting may also be accomplished by applying an excessive voltage between terminals. While, however, the operating voltage increases directly as the length, the starting voltage in-

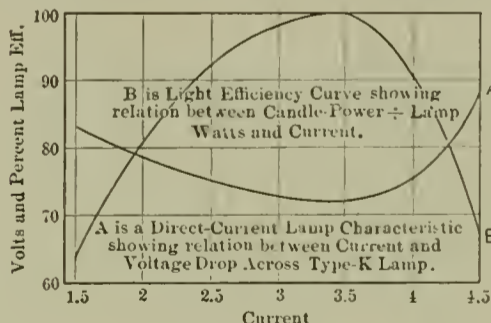

FIG. 6.—CHARACTERISTICS OF MERCURY VAPOR LAMP.

creases more nearly as the third power of the length.

In the alternating-current lamp, shown in Fig. 4, the starting is effected by means of a small electrode or pin placed in the head of the lamp

and connected to one of the positives through a rather high ohmic resistance. In starting, the tube is tilted so that the mercury forms a continuous stream from the negative to the positive end and is carried by its momentum into contact with the pin.

On account of the irregularity of the flow of the mercury it here makes and breaks contact with the pin a number of times, each time causing a breakdown of the negative electrode resistance, either on the column of mercury or the pin. In the latter case, the lamp will go out at the end of the alternation. If, however, the mechanical break at the pin occurs during such an alternation that the mercury column is the negative the lamp will start to operate upon the pin, and that main positive electrode to which the pin is not connected as positive electrodes and the mercury stream as the negative. Then, on account of the starting resistance connected with the pin, the current will be immediately transferred from it to the corresponding positive, and the lamp is started.

## NEGATIVE ELECTRODE.

As in all other arcs, there is a rapid evaporation from the negative electrode, which gives rise to violent agitation on the surface of the mercury, and at the point of maximum activity causes a marked depression. The evaporated mercury is cooled and condensed by contact with the bulb, on the inside of which it collects in drops. The drops grow larger until they run down into the electrode. In converters the main object is to get as much cooling surface as possible with the shortest practicable vapor path, but concentration of heat and a long arc are essential for lighting.

## CHOKE COIL.

With small currents there is a tendency for the arc to fluctuate, and it is usual to provide a choke coil to keep down the fluctuations. This tendency practically disappears with currents over 4 or 5 amperes.

Only choke coils with open magnetic circuits can respond quickly enough to be of service in counteracting this impulse. The capacity of the wires between choke coil and tube should be as slight as possible, as it has been found that a twisted pair of insulated wires, 10 feet long, has a perceptible weakening action on the coil if connected between it and the negative electrode.

# Systematic Testing of Oil in Transformers and Methods of Reclaiming Oil for Service

H. N. N.

**O**WING to the fact that several transformer breakdowns were found to be caused by the poor condition of the transformer oil, it

finger is released for a moment until the oil in the sneak is at the same level as in the transformer. The sneak is again closed and rapidly drawn out,

serial and company numbers of the transformer are then noted, together with the number of the jar, also condition of case, whether leaky or dirty, and condition of terminals, whether dirty or loose. This is repeated, using a jar for every transformer sampled until all jars are filled.

It is important that both sneak and jars be clean before taking any sample from a transformer, as dirt or moisture may be carried over from a previous sample. A piece of cloth, which will not fur or fray out, is satisfactory for the purpose; for cleaning the sneak it may be attached to a rod or stiff wire and the tube cleaned in a similar manner to a gun barrel.

After the necessary number of samples have been obtained they are taken to the laboratory and tested.

The testing arrangement consists of a step-up transformer (110 to 22,000 volts), and a variable impedance connected in series with the low-tension windings, which are protected by circuit breaker and fuses. The oil-testing cup is of the standard design made by the Westinghouse Electric & Manufacturing Company of 200-c.c. capacity.

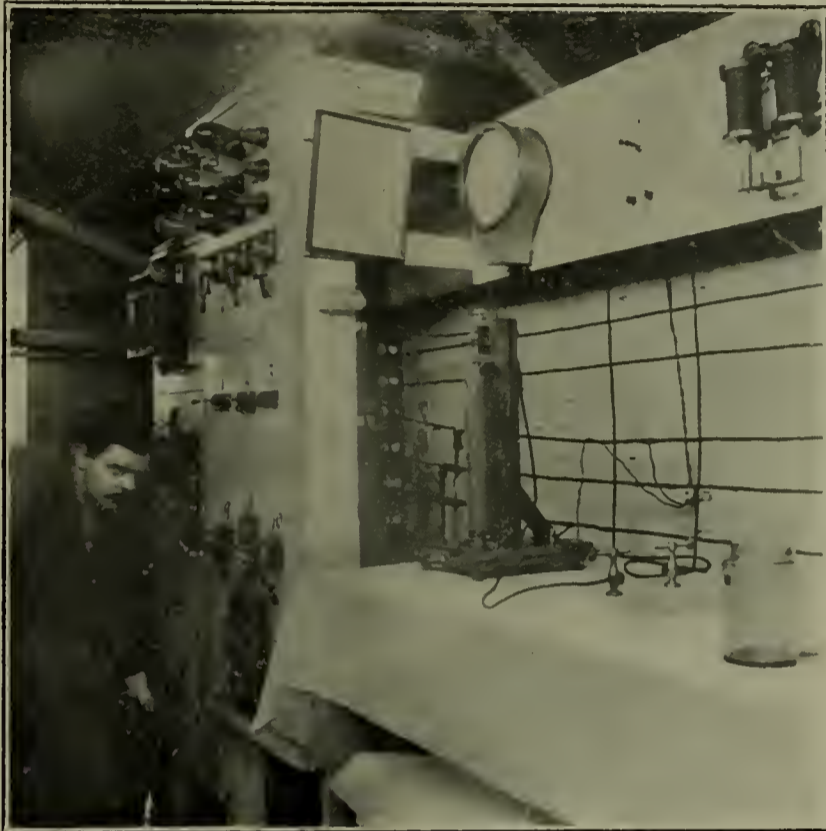

FIG. 1. —TESTING CUP AND SPARK GAP.

was decided to begin a regular inspection of the oil to determine its condition.

A sample kit was built containing two shelves, each holding six pint jars. Each jar is numbered and held by spring clips mounted on the back. The shelves are provided with separate doors which swing through an angle of 90 degrees, allowing easy access to the interior. The kit is provided with a handle and is of such shape that it may be easily carried. When filled, it weighs 28 $\frac{3}{4}$  lb.

Provided with this kit, a note-book and an oil "sneak," which is merely a tube long enough to reach to the bottom of any transformer, and of such diameter that one end may be closed with the finger, the oil inspector goes from station to station.

After removing the cover from the transformer to be sampled, and making sure that both oil jar and sneak are clean, one end of the sneak is closed with the finger and the sneak immersed in the oil, taking care to keep clear of the terminal boards, so as to avoid a short circuit if the apparatus is energized.

When the sneak strikes bottom the

its lower opening brought over the mouth of the jar and the finger released, thus emptying the sneak. This is repeated until the jar is filled. The

The breakdown voltage, or rather the disruptive strength, is measured by means of a standard spark gap between needle points. The needle

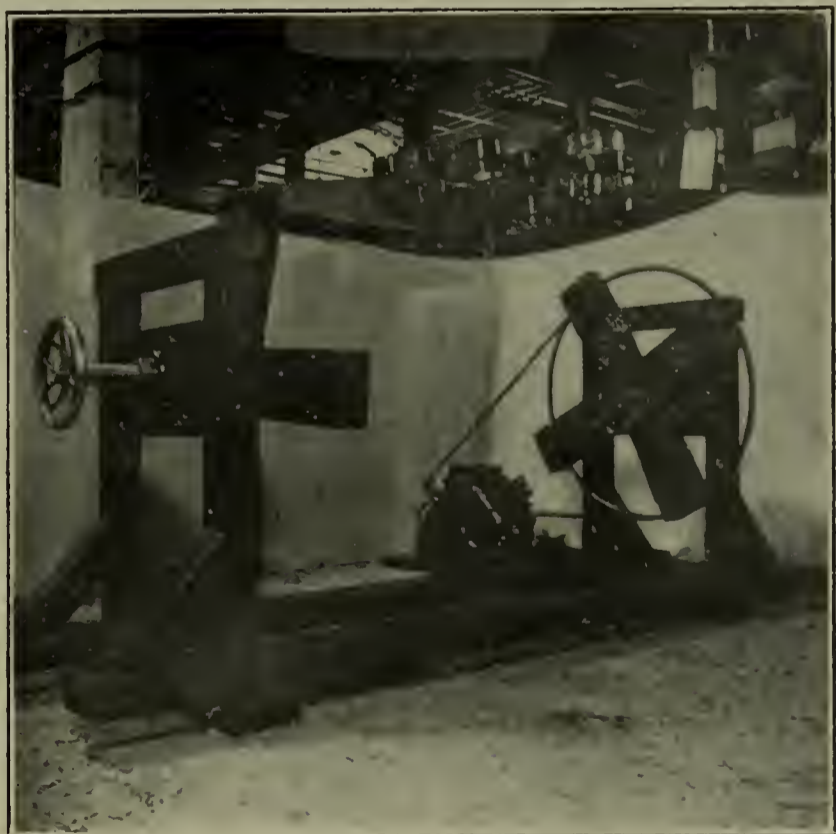

FIG. 2.—DRUM-CLEANING MACHINE.

spark gap is adjusted to 0.725 in., which is equivalent to 15,000 volts (sine wave) breakdown. The needle spark gap and the oil-testing cup are connected in parallel to the high-tension terminals of the transformers.

just below a dull red and then plunged into the oil. Any hissing or crackling sound denotes the presence of moisture.

After these tests have been completed the operator fills out an "Oil-

the transformer is thoroughly cleaned; all contacts gone over and any necessary repairs made to both case and core, and then refilled with approved oil.

When using the pump for this purpose a small amount of oil should be drawn off before discharging into the transformer, in order to remove any dirt which may have been lodged in the pump while emptying the transformer.

The drums containing the defective



FIG. 3.—DRUM-CLEANING MACHINE WITH DRUM IN PLACE.

When making a test the oil cup and electrodes are thoroughly cleaned and the cup filled with oil from one of the sample jars to the 0.198 c.c. point. The upper electrode is then inserted, which will cause the oil level to rise to 0.200 c.c. The sparking distance is adjusted by means of a micrometer screw to 0.15 in.

After the oil has been allowed to stand for about five minutes in order to free it from air bubbles, the impedance being all in series with the transformers, the current is thrown on and the potential gradually increased until the oil gap or the air gap breaks down.

If the oil gap breaks down the oil is classed as defective, because its breakdown point is below the limit (15,000 volts per 0.15 in. gap). If the air gap breaks down it shows that the oil will stand 15,000 volts, and is in satisfactory condition.

In case of doubt, the oil cup should be emptied and the test repeated with a new supply from the same jar. The oil cup and electrodes should be thoroughly cleaned and the needles renewed between tests.

After the breakdown test has been completed about a half pint of each sample is put into a clean cup and tested for moisture. For this purpose a one-pound soldering copper will answer admirably. It should be used for no other purpose. It is heated until

Note.—C. C. stands for cubic centimeters.

Test Report," to which he transfers all data. The reports are sent to the engineering department and noted. In case the oil does not come up to the requirements, orders are issued to have it replaced.

The transformer is then cut out of service and the oil drawn off into

oil are then labeled in a proper manner and sent to the laboratory. The oil is passed through a combined filter and dryer and is discharged into clean drums where it is allowed to settle, and, just prior to shipment, another sample is drawn from the bottom of each drum and tested as described above. If it passes this test the sample is preserved and properly labeled until the drum from which it was taken has been emptied.

The filter used by this company is a standard oil-cleaning device, and

Form 105 6-107

**SHIP TO**

---

Care of \_\_\_\_\_

**TRANSFORMER OIL**  
FROM  
**THE ALLEGHENY COUNTY LIGHT CO.**  
**RETURN DRUM TO LABORATORY**  
**GOOD OIL—READY FOR USE**

FIG. 4.—SHIPPING TAG.

Form 280-6-7-07

**TRANSFORMER OIL TEST REPORT.**

Tested by E. H. Fisher Date 7-23-1907

Kind of Oil Trancil

From Turtle Creek Station

Transformer Co. No. 4114-3 Serial No. 83796

Test No.	Striking Distance	Break Down Voltage	Moisture Test	REMARKS
1	Standard	Defective	Moist	<u>Oil very dirty</u>
2				<u>Case leaking</u>
3				
4				
5				<u>One L. T. terminal loose</u>

Note: Striking Distance on Standard Test to be 0.15 Inch

FIG. 5.—OIL-TEST REPORT.

steel drums. This may be advantageously done with a small centrifugal pump. As soon as part of the transformer core is exposed the discharge may be turned on the core and all deposits of dirt washed off and the oil ducts cleaned.

After the old oil has been removed,

equipped with resistance coils wound on a jacket surrounding the oil reservoirs for the purpose of raising the temperature of the oil above the evaporation point to obtain moisture at the time it is circulating through the filtering cells.

Complete filtering and dehydrating

equipment on a self-contained base and equipped with motor-driven pump is now manufactured by the Westinghouse Electric & Manufacturing Company, but at the time this work was planned by us and the apparatus purchased, such a special device was not available.

The drums are cleaned by the following method:

The drum is mounted in a frame between two pivots in such a manner

that it may be revolved axially at about 30 rev. per min. by means of a small motor. Before starting the motor several handfuls of slugs or nuts and several quarts of gasoline are placed in the drum. It is then rotated until the scale and dirty oil have been removed.

The estimated cost of inspection, test, filtration, and all charges incidental to handling and transportation, is about two cents per gallon, this be-

ing roughly about 10 per cent. of the cost of new oil.

This system has been in operation about one year, and 85 per cent. of all transformers tested were condemned and the oil changed and filtered; of these, none have shown breakdowns or discharges through the oil.

The defective oil drums are labeled with a red label, and the filtered oil is labeled with a similar white label, as shown in the illustration.

## Novel Single Phase Textile Motor Installation

THE three-phase induction motor has long held an enviable position in the operation of all classes of machinery on account of its

the inherent advantages of the three-phase induction motor have long been known and appreciated, but while their use has been confined to the

advent of the single-phase induction motor has opened up a new field for the textile industry: viz., the operation of mills in the suburbs or sections of the city supplied only with single-phase current for lighting purposes.

An interesting example of the application of single-phase motors to the operation of textile machinery, and one that is worthy of notice, is found in the factory of the Ayvad Mfg. Co., of Hoboken, N. J. The product of this company is the well-known "water-wings," a device used by bathers and beginners in swimming to assist in floating the body.

The style of drive used throughout is what is commonly known as the group drive, in which a number of machines are driven by a motor from counter-shafts. The electrical installation, consisting of nine single-phase induction motors, of a total capacity of  $75\frac{1}{2}$  h. p., was furnished by the General Electric Company. The type of motor used is one recently developed by the above company for operation on single-phase circuits and is known as the Form KG.

The conditions influencing the final decision in favor of the single-phase

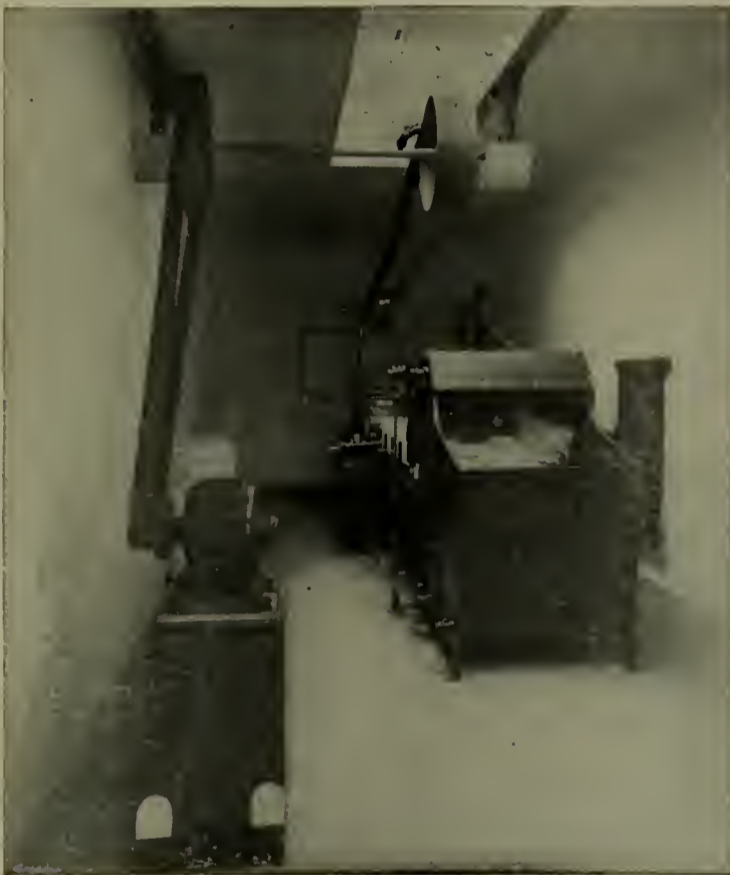

FIG. 1.—PICKER-ROOM SHOWING METHOD FOR COUNTER SHAFT CONNECTION TO  $7\frac{1}{2}$  H.P. KG MOTOR.

excellent starting characteristics and its ability to give constant and reliable service with a minimum of attention and repairs. The single-phase motor, on the other hand, has not been so fortunate in gaining the attention of both manufacturers and power stations on account of its poor starting characteristics, and for years the manufacturers of single-phase motors have centered their efforts on the production of a motor having all the desirable features of the polyphase motor.

The General Electric Company has perfected a single-phase motor that is remarkably free from the defects usually found in single-phase motors, and which bids fair to become a successful competitor of the polyphase motor in the field of small motor-driven machinery.

For the driving of textile machinery

operation of mills supplied with polyphase current from either central power station or isolated plants, the

alternating-current motors were that the factory was located in a part of the city supplied with single-phase al-



FIG. 2.—TWO 10 H.P. 220 VOLT KG SINGLE-PHASE MOTORS DRIVING A SEPARATE LINE SHAFTING, FROM WHICH ARE DRIVEN CARDING MACHINES, DRAWING FRAMES, ROVING MACHINES AND FLY FRAMES.

ternating current for lighting, and that the motors used must operate without affecting the lights on the same circuit; also that all sparking of motors must be entirely eliminated.

Ayvad Mfg. Co. was to buy the cloth used in the manufacture of their product from textile mills, their factory converting the fabric into the finished product. Since it was impossible to

supply the demand. Any excess of cloth produced forms a profitable side line. The factory when in full operation will furnish employment for about 60 persons, and will require



FIG. 3.—A VIEW OF THE SPINNING ROOM AND TWO OF THREE 10-H.P. MOTORS DRIVING 12 SPINNING FRAMES WITH A TOTAL CAPACITY OF 3000 SPINDLES. NOTE SHEET-IRON ARCHES OVER THE PASSAGE WAYS TO PROTECT EMPLOYEES FROM ACCIDENTAL CONTACT WITH THE BELTS.

This last condition is one peculiar to textile mills, for in the early stages of cloth manufacture the cotton is in a highly inflammable condition, and the least spark might start a disastrous fire. A thorough investigation of the

properly inspect every yard of the cloth for flaws, there often resulted a product of inferior quality. Delays in shipment and in transportation further added to the difficulties of manufacture.

To avoid all the delays and to insure a good uniform quality of cloth,

an average of about 5000 lb. of cotton weekly.

The view of the picker room, as shown in Fig. 1, gives the method of counter-shaft connection to the motor.

The power required for running the picker is about  $7\frac{1}{2}$  h.p. The picker room was built as an annex to the main factory, and to provide sufficient light for working a skylight was placed in the roof and the walls painted white.

The two 10-h.p. motors shown in Fig. 2 drive separate line shafting, from which are driven the carding machines, drawing frames, roving machines and fly frames. In this same room the lines from the power circuit enter through the necessary switches, protective devices, measuring instruments, etc.

In Fig. 3 is shown a view of the spinning room and two of the three 10-h.p. motors driving 12 spinning frames with a total capacity of 3000 spindles. The third motor, not shown in the view, drives a spooler and one warp machine. All motors are installed on platforms suspended from the ceiling and drive the spinning frames through countershafting. Sheet-iron arches over the passage ways protect employees from accidental contact with the belts. In the background of the picture may be seen the starting-boxes for the motors. All the starting-boxes are installed on slate panels with a backing of sheet asbestos.

In the view of the loom room shown in Fig. 4 may be seen the 10-h.p. motor driving the looms. It was calculated that about  $7\frac{1}{2}$  h.p. would be required to drive the looms and a slasher not shown in the view. This leaves an ample margin in additional horse power should it be found necessary to install other looms.



FIG. 4.—10 H.P. 220 VOLT KG SINGLE-PHASE MOTOR IN LOOM ROOM.



FIG. 5.—5 H.P. 220 VOLT KG SINGLE-PHASE MOTOR DRIVING LINE SHAFTING, FROM WHICH ARE DRIVEN CUTTING PRESSES AND SPECIAL MACHINES USED IN SHAPING AND FINISHING, AND THE DRIVING PRESS SHOWN IN THE FOREGROUND. NOTE THE NEAT JOB OF WIRING AT THE MOTOR.

single-phase motor finally selected satisfied the manufacturers that all conditions were met in the design of the motor, all commutators and brushes being eliminated.

Until this year the practice of the

a complete textile equipment from picker to loom was installed. The textile equipment now enables them to operate the factory during the entire year, where heretofore only six months' operation was sufficient to

The 5 h.p. shown in Fig. 5 drives a pony cylinder printing-press, also line shafting from which are driven cutting presses and other special machines used in shaping and finishing the "wings." The printing-press is used for printing the design on the cloth, and also for printing advertising pamphlets and circulars. On this same floor a 3-h.p. motor drives a group of special sewing machines.

The entire plant is well equipped, roomy, and modern in every respect. While an excellent example of the methods in which single-phase motors may be advantageously applied to the operation of textile mills, it also brings forward to central-station managers the possibilities existing in territories reached by single-phase distribution lines.

It is expected that the adoption of the electric drive at this plant will result in a maximum output with minimum operating and maintenance expenses, as has been proved in similar cases, not to mention the additional advantages of cleanliness and flexibility that go far toward making this method of machine drive popular with manufacturers.

## The Rosenberg Generator\*

B. M. EOFF

The distinctive characteristic that renders the machine especially valuable for certain purposes is its tendency to deliver a constant current at variable speed, and a constant output at constant speed. The means taken to secure these results are very simple and eminently effective; they consist, essentially, in short-circuiting what in an ordinary dynamo would be the service brushes, and in placing the actual service brushes at points on the commutator midway between those of

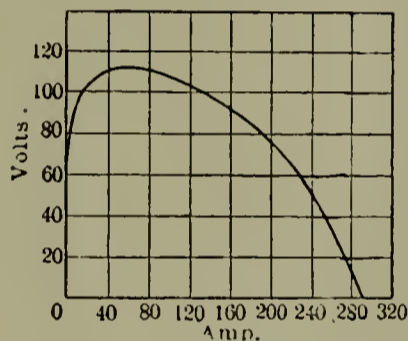

FIG. 1

the first set. The field cores, at least in the case of a series machine, are designed for a much higher degree of saturation than is usually the case in an ordinary dynamo, and the pole pieces are of different shape and of greater size. In appearance the machine differs but little from a normal generator.

Tests made at Schenectady on a one-kilowatt Rosenberg generator showed a voltage of 30 when the speed was 1200 rev. per min.; the speed was then increased to 2600 rev. per min., and the voltage rose to 30.5, and then fell back to 30; thus, with an increase in speed of more than 100 per cent., the voltage increased but five per cent., while the variation in current was slightly smaller.

At the beginning of the curve the characteristic is ascending (Fig. 1).

At a small value of the current, however, the field cores become highly saturated, due to their relatively small area and the large number of turns upon them, while the iron of the armature and that of the heavy pole shoes is still at a very low density. Any

increase in current above this value has practically no effect upon the strength of the primary field, but produces in the large volume of iron in the armature core a counter flux which is almost proportional to the current, and owing to this condition, the machine has for the most part a drooping characteristic.

By suitably dimensioning the various parts of the machine, it is possible to obtain a short-circuit current which will exceed the normal current by any required amount, say 25, 50, or even 100 per cent., while on the other hand, the maximum voltage may be made to exceed the normal voltage by a corresponding percentage; furthermore, the machine may be designed to give a drop in voltage almost exactly proportional to the increase of current.

The current for a given voltage may be reduced to any desired value by placing shunts of different resistance across the series field; in which case the field current will no longer be equal to the current at the brushes. Fig. 2 shows the effects of connecting these resistances in parallel with the field winding. The decimal given in connection with each curve represents the proportion of the total current that is flowing in the field.

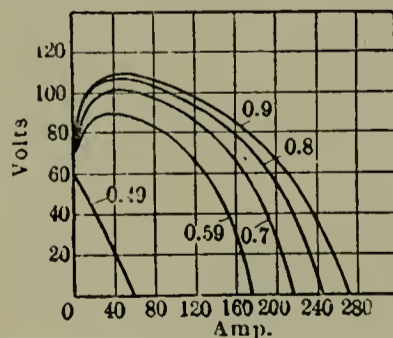

FIG. 2

The curve marked 0.9 of Fig. 3 shows the currents corresponding to different voltages across the arc of a lamp designed for 60 volts and 200 amperes, the lamp being connected to 220-volt constant voltage mains. The curve shows the performance of the lamp without ballast, when connected to a Rosenberg series generator; the

generator having a low resistance shunt connected in parallel with its field windings. In a lamp connected in series with a ballast consuming only 100 per cent. or less, of the amount of power expended at the arc, the variations of current are greater beyond all comparison than those obtained with the Rosenberg generator.

With a complete short circuit, the machine will require but little more power for driving than when open-circuited.

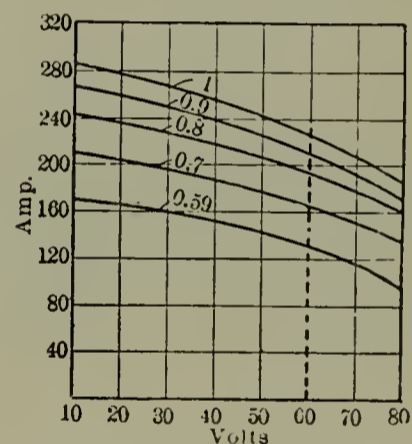

FIG. 3

This last named feature of the generator, *i. e.*, the inherent impossibility of its being subject to heavy overload, opens up another extensive field of application for the machine in connection with gasoline-electric conveyances, both for railway service and for street bus lines; taking as an example of the latter, for instance, the Fifth Avenue bus, of New York City.

The Rosenberg generator may be further used as a reversible booster placed between two sources of variable voltage, such as a battery of 50 cells and a 110-volt generator; the voltage of the latter vary between 90 and 130 volts. If the voltage of the generator and battery are the same, a current equal to the short-circuited current flows through the booster, since the terminals of the machine are at the same potential. If, however, the voltage of the generator is greater than that of the battery, the current through the booster will increase slightly above the short-circuited cur-

\*General Electric Review.

rent, and the booster will generate a negative voltage; in other words, the machine will run as a motor, consuming the difference between the voltages of the generator and battery. Should the voltage of the battery be greater than that of the generator, a current somewhat smaller than the

short-circuited current will flow, the booster will generate a positive voltage, and the potential between the two circuits will thus be equalized. The machine, when used as an ordinary booster for charging accumulators from constant voltage mains, will require no regulation throughout

the whole range of charging, from full discharge to complete charge. The current decreases with progressing charging, either very slowly or at any predetermined rate, depending upon the design of the machine, while the voltage of the booster adjusts the line voltage to that of the battery.

## Tungsten Series Incandescent Lamps at Grosse Point, Mich.

THE city of Grosse Point, Mich., has recently installed a series tungsten incandescent street lighting system where the advantages of this kind of lighting are well exemplified. The station equipment consists of two 8.8 kw.  $5\frac{1}{2}$  ampere con-



FIG. 1.—ORNAMENTAL POLE CARRYING SERIES TUNGSTEN LAMPS, GROSSE POINT, MICH.

stant current transformers. One of these is held in reserve, while the other supplies current to 77 60 c-p. General Electric tungsten series incandescent lamps, suspended from artistic iron poles. All wiring is laid in conduits to the pole, and wires pass up the center of the pole to the lamps.

One of the interesting features of this system is the radial reflector with

which the lamps are equipped. This form of reflector, which was recently developed by the General Electric Company, is so constructed that the light is spread and projected very evenly over considerable area instead of being nearly all concentrated in a circle around the lamp. Fig. 2 shows the candle-power distribution of a 40 c.p. series tungsten lamp equipped with a radial reflector. Fig. 3 shows one of those reflectors on a lamp. It may be seen from the diagram of the candle-power distribution that at about 30 degrees below horizontal the effective illumination is 50 c-p., making the efficiency at this point about one watt per candle-power.

The series sockets with which these lamps are provided are so constructed that when a lamp is removed from the socket two contact plates of large area close together before the lamp is quite drawn out of the socket, leaving no danger of an open circuit at any time.

Tungsten series lamps are made in 32, 40 and 60 c-p. sizes, with current ratings of 4, 5.5, 6.6 and 7.5 amperes, and are exceedingly hardy on account of the heavy short filament. They will burn for nearly 1000 hours at efficiency of from  $1\frac{1}{4}$  to  $1\frac{1}{2}$  watts per candle-power.

Another installation of series tungsten lamps for street lighting has recently been made in Grand Rapids, Mich. The lamps are of 60 c-p., and were placed on one of the principal streets of the city. Judging from the

complimentary remarks of the press and the city council, the test installation has proved highly satisfactory.

The tungsten lamp with its high efficiency should greatly increase the use of series incandescent lights in

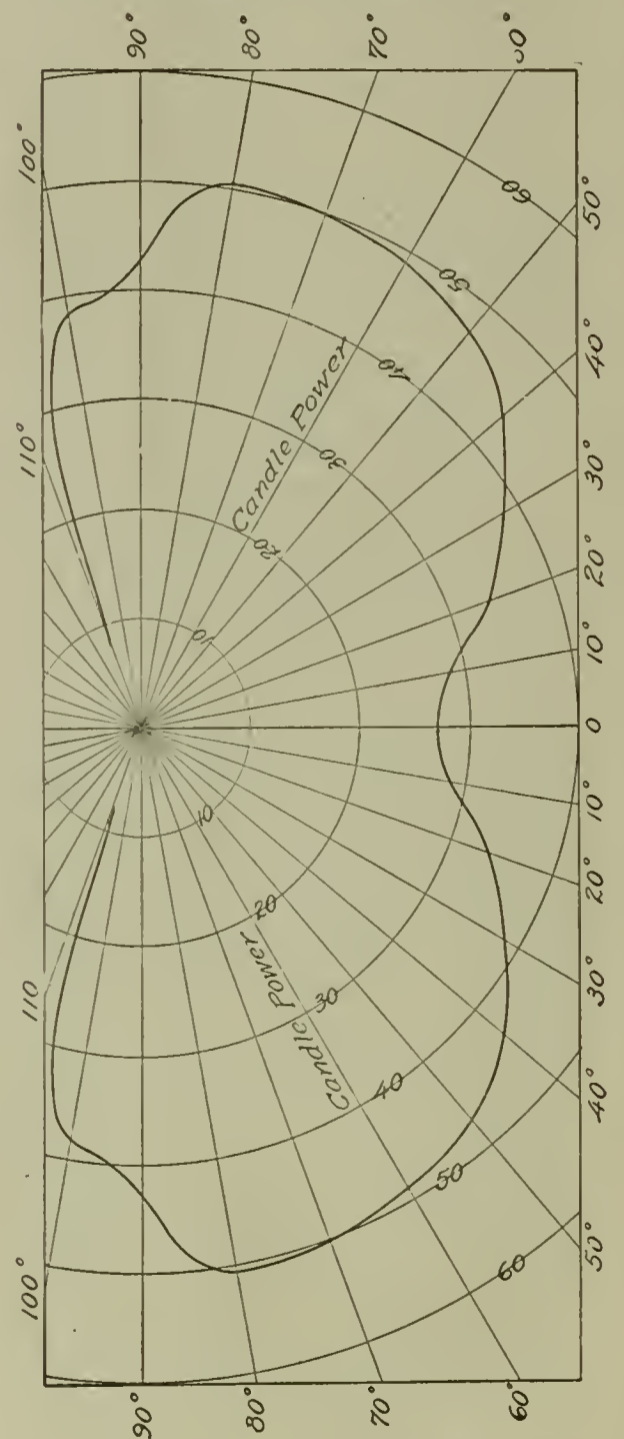

FIG. 2.—CANDLE-POWER DISTRIBUTION OF 40 C. P. SERIES, TUNGSTEN LAMP EQUIPPED WITH GENERAL RADIAL REFLECTOR.



FIG. 3.—DETAILED VIEW OF LAMP BRACKET AND REFLECTOR.

suburban and residential districts where the thick foliage makes it necessary to have the units distributed at short intervals to produce satisfactory illumination.



# Electric Locomotive—Continued

H. L. KIRKER

Copyright 1907

## DYNAMO—VOLTAGE.

NOW that we have the toy motor armature rotating continuously in a counter-clock direction we will focus our attention on the disturbance going on in the air gap under the north pole. The main vortex—the field magnetism—has a clockwise direction. The current in the armature wire under the north pole is from front to rear and its vortex is likewise clock direction. This armature wire is moving in toward the axis of the field. It is cutting lines of force. This cutting, as Faraday discovered, sets up an electric tension, or voltage, a tendency to drive a current along the cutting wire. Note the

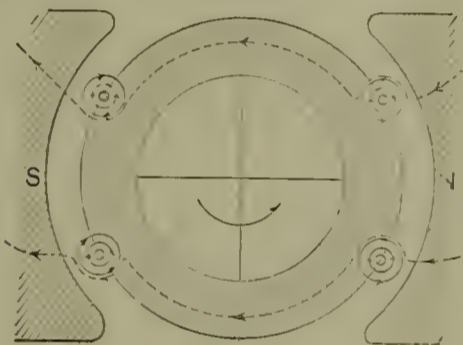

FIG. 21.

curvature of the dent the wire makes in the field. It corresponds to a counter-clock direction of vortex. This corresponds to a current from rear to front. That is the point I want you to note. The line voltage drives the current from front to rear. The induced pressure is from rear to front. The induced voltage opposes the line voltage (see Fig. 21).

Now, if by some means we could increase the induced voltage until it equaled the line voltage, why no current would flow, of course. Also, if we increased the induced voltage still further the armature voltage would force a current into the line. We can accomplish this result by increasing the speed of the armature, say by belting it to a steam engine. Note again, that when the current flows from rear to front the whirl around the armature wire is counter-clock, consequently, external force has to be applied to the armature wire to move it in toward the axis of the field, whose direction is clockwise. The steam engine supplies the necessary force. We have, then, an electric machine whose direction of field is clockwise, whose

direction of armature rotation is counter-clockwise. This armature is belted to a steam engine whose direction of rotation is likewise counter-clock. We see that the induced electric pressure in the wire under the north pole is from rear to front and that when current flows in this direction the steam engine has to do work to force the wire in this counter-clock direction. We also see that if we force a current through the armature wire from front to rear in opposition to the induced voltage, that the wire tends to move in the same counter-clock direction and would keep the engine running with the steam cut off. Our toy machine, then, revolving counter-clock direction in a clock-direction field, can play the part either of the motor or the dynamo. As a motor, it takes current from the line and transforms it into available power at the pulley; as a dynamo, it absorbs the power of the steam engine and transforms it into current. It is the same field, the same armature, the same commutator, the same direction of armature rotation. In one case we supply current and get motion, in the other we supply motion and get current. The lines are cut in the same way in both cases; the induced voltage is the same in both instances. As a dynamo the induced voltage drives a current into the line. As a motor the induced voltage opposes the current from the line.

I stated that we could increase the induced voltage by increasing the armature speed. We know from experiment that the induced voltage depends upon the rate of cutting lines of force. We can increase the rate by increasing the speed, or by increasing the number of wires in series on the armature, or by increasing the number of lines in the field. We can increase the number of lines in the field by increasing the number of ampere turns on the field. However, we are not here concerned with the various combinations of speed, armature winding and field strengths. That is the work of the designing engineer. He must properly proportion these. But it is not necessary to qualify as a designing engineer to be able to see that induced voltage depends on the rate of cutting lines of force, and that an armature wound with a few turns of heavy wire can deliver a low-voltage, heavy-amperage

current, and that an armature wound with many turns of fine wire can give a high-voltage, light-amperage current. In general, the voltage depends on the rate of cutting lines of force, and the amperage that can be safely carried depends on the size of the wire. That is as far as we need go into the subject of dynamo design.

## TWO MACHINES IN PARALLEL—TORQUE.

We have just been considering the forces exerted in the air gap of the dynamo and motor, and saw that for a given direction of field and armature rotation that the direction of the armature current decides whether the machine is acting as a motor or as a dynamo. Keeping this in mind, I will ask you to direct your attention to the

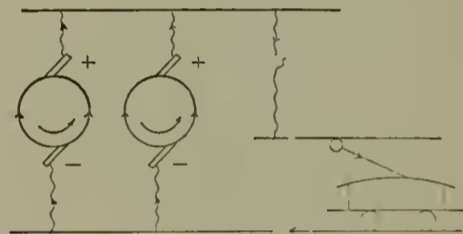

FIG. 22.

case of two similar machines operating in parallel. Let them be street railway generators supplying current to the same line. We will assume the voltage to be 500, the speed 500 r. p. m., the direction of armature rotation counter-clockwise, the fields separately excited, the direction of the field magnetism clockwise and the load on each machine 500 amperes just before the line switches opened (see Fig. 22). The load has disappeared, but each armature continues to generate 500 volts, and since they are connected in parallel to the same bus-bars each armature tries to drive a current through the other, but as their voltages are equal, why, of course, no current flows. Suppose, however, that the governor of engine No. 1 does not hold the speed constant, that engine No. 1 speeds up slightly, say, two per cent., the voltage of generator No. 1 rises in the same proportion. Generator No. 1 is now giving 510 volts. No. 2 is giving 500 volts, consequently, there is 10 volts unbalanced pressure between the two armatures, and current begins to circulate. The 510 volts of No. 1 drive current against the 500 volts of No. 2. You can readily imagine that the greater

the difference in voltage between the two machines, the greater the current will be that circulates between them. In fact, the amperes can be found by dividing the effective volts by the ohms resistance. Here the effective volts are 10 volts. If we assume the resistance of the circuit to be 0.1 ohm, why the current will be 10 divided by 0.1 or 100 amperes. But we are not here concerned with the calculation of currents. What I want you to note is that the same current (100 amperes) is flowing in both armatures and that in No. 1 it is flowing in the direction of the induced pressure, from rear to front, under the north pole, and in No. 2 it is flowing against the induced pressure, from front to rear, under the north pole (see Fig. 23). Machine No. 2 therefore is motoring. The field strength is the same in both machines. The armature current is the same in both machines; consequently, we will be justified in assuming the force exerted on an armature wire of machine No. 1, the generator, to be the same as the force exerted by a similarly situated arma-

ture of the turning force exerted by the motor armature current. A prony brake would give us an accurate measure. We can readily see that the greater the motor current is the greater the torque will be. Likewise, the greater the current delivered by machine No. 1, the generator, the greater the force that will have to be exerted by the steam engine to drive the generator armature around. We saw that current began to circulate between the two machines as soon as the variation in speeds disturbed the equilibrium of voltage; consequently, the greater the in speed, the greater the difference in voltage, consequently, the greater the current, therefore the greater the torque. A given current in machine No. 2 will exert a given torque, and accordingly life a given load on the elevator to which we supposed No. 2 to be coupled. If a bigger load be put on the elevator, a bigger current will have to flow or the motor will stall. What happens, of course, is that the motor armature drops in speed until the difference in voltage between the motor and the generator

is small. As a specific case, let the line voltage be 500 and the armature resistance 0.1 ohm. Let the field be separately excited and the armature winding and field strength be such that one r. p. m. gives one volt. Under these conditions, if the armature revolves 490 r. p. m., it will give 490 volts, which is 10 volts less than the line pressure. There is therefore 10 volts unbalanced pressure. One volt will drive one ampere through a resistance of one ohm, one volt will drive 10 amperes through 0.1 ohm, consequently, 10 volts will drive 100 amperes through the 0.1 ohm armature resistance. The 100 amperes will enable the motor armature to give a certain torque. Suppose we double the load on the motor. Twice the torque will be required, consequently, twice the current, or 200 amperes must flow through the motor armature. This means there must be an unbalanced pressure of 20 volts. The speed drops accordingly to 480 r. p. m. We see, then, that doubling the load on the motor simply meant a drop in speed from 490 to 480, a change of

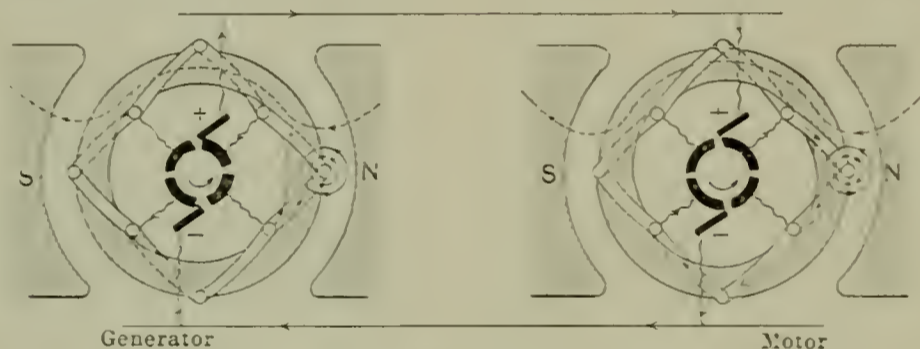

FIG. 23.

ture wire of machine No. 2, the motor. In machine No. 1 the direction of the field magnetism is, as stated, clockwise, and the direction of the armature current in a wire under the north pole is from rear to front, the direction of the whirl around the 100 amperes in this wire is therefore counterclockwise. Consequently, an external force must be applied to this wire to make it move in toward the axis of the field. The steam engine supplies this force. In machine No. 2 the similarly situated armature wire is carrying 100 amperes from front to rear and is accordingly surrounded by a whirl whose direction is clockwise, consequently, this wire exerts, as stated, an equal force in moving in toward the axis of the field. This turning force exerted by the motor armature current is called torque. If the steam be shut off of engine No. 2 the motoring machine will keep the engine running. If there were some way of shifting the belt from the pulley of engine No. 2 to the pulley of a counter-shaft geared to an elevator, we could make the motor lift weights and could accordingly get a rough meas-

is sufficient to drive a current through the motor armature that will give the required torque. The increased load on the motor calls for an increase in the motor torque. Increased torque means increased current in the motor armature. Increased motor current means increased generator current. Increased generator current means increased drag on the generator armature wires. Increased drag on the generator armature wires means increased steam consumption, consequently, it is the expansion of the steam that does the work after all. The force exerted in pushing a current-carrying wire across the magnetic field of the generator in a direction the wire does not want to go, and the force exerted by a current-carrying wire in traveling across the magnetic field of a motor in the direction the wire wants to go are merely intermediate steps in the transfer of heat into motion.

## VOLTAGE—SPEED.

We have just seen that the motor responds to an increased load by a drop in speed. But the drop in speed

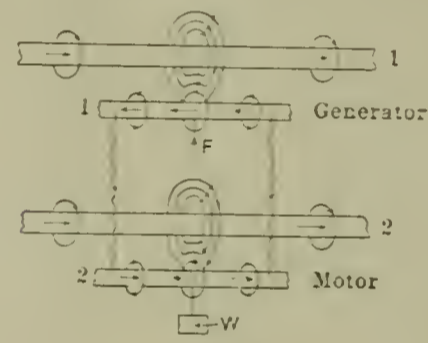

FIG. 24.

about two per cent. Had the armature resistance been half as great, why half as much unbalanced voltage would have doubled the current, in which case the variation in speed would have been, approximately, one per cent. In fact, this type of motor is practically a constant-speed motor, from no load to full load, as long as the line voltage remains constant.

If we increase the line voltage the motor will speed up until the unbalanced voltage is just sufficient to drive the required current through the armature. If the line voltage drops the speed drops. Assuming the resistance to be 0.1 ohm and that one revolution per minute gives one volt, and that 100 amperes are required to give the necessary torque, we see that if the line voltage is raised to 1010 the armature will have to speed up to 1000 r. p. m. to keep the unbalanced voltage at 10 volts. Likewise, if the line voltage dropped to 110, the armature speed would have to drop to 100 r. p. m. to keep the unbalanced voltage at 10 volts. If the line voltage dropped to 10 volts the motor would stall, for we

assumed 100 amperes to be the current required to give the necessary torque. If the motor did make one revolution per minute with this line voltage, it would generate one volt. Consequently, the unbalanced pressure would be nine volts, so only 90 amperes would flow. But 90 amperes could not lift the load, so the load on the motor would not allow the armature to turn.

We see, then, that the motor armature runs at a speed that allows the necessary current to flow. For a constant line voltage the speed is practically constant for big variations in the motor load. But if the line voltage varies the motor speed varies with it. The torque varies with the current, the speed with the voltage. These two facts bring us to our next point, the work done in an electric circuit.

#### WATTS.

In the specific case that I just called your attention to, I assumed that one revolution of the armature per minute gave one volt, and we saw that for a line voltage of 500 volts the motor armature made about 500 r. p. m., and for a line voltage of practically 1000 volts the armature made 1000 r. p. m. In fact, the speed was a measure of applied volts. We can also assume that the armature winding and field strength were such that one ampere gave a torque of one pound. Consequently, 100 amperes would give a torque of 100 lbs. The amperes then can be taken as a measure of the torque. Hence, if we can measure the amperes we know the force exerted by the motor, and if we can measure the volts we know the speed—the space through which the force is exerted per minute. The product of force by the space through which the force is exerted per minute is the rate of work. The product of the volts by the amperes, then, is a measure of the rate of work. We, of course, can measure the work done per minute by the motor by the means of a brake. The result is expressed in foot-pounds per minute. Foot-pounds per minute divided by 33,000 gives, as perviously stated, the horse-power. There is an exact relation therefore of the product of current by volts to horse-power. The product of one volt by one ampere is called a watt. The size of the volt and the ampere are so taken that 746 watts equal one horse-power. One watt therefore is  $\frac{1}{746}$  of a horse-power.

The voltage applied to incandescent lamps is usually 100 volts. This voltage drives a half ampere through each lamp. The product of 100 volts by one-half ampere means 50 watts, or about  $\frac{1}{15}$  of a horse-power. Fifteen-

lamps, then, would require a little more than one horse-power of energy. Fifteen hundred such lamps would require a little more than 100 h. p., and 15,000 lamps would require a little more than 1000 h. p. Fifteen thousand lamps at 50 watts each means 750,000 watts, or 750 kw. So far as the steam engine is concerned, the work it does is the same whether these 750 kw. are used to run a motor or to furnish light.

We see, then, that the product of the current by the volts is a measure of the rate at which the electric current does its work. The current is the measure of the force, and the volts are a measure of the space through which the force is exerted per minute. These facts are easily verified by measuring the foot-pounds of work done per minute by a motor. The indicator and the speed-counter are a measure of the work done by the steam engine. The ammeter and the voltmeter are a measure of the work done by the generator. The prony brake and the speed-counter are a measure of the work done by the motor. Increased brake friction on the motor means increased kilowatts output at the generator and increased steam consumption on the part of the engine. The motor reproduces, minus the losses, the work done by the steam engine. If there were no losses in transmission the kilowatts output of the generator would equal the brake horse-power output of the engine, and likewise would equal the brake horse-power output of the motor.

In a system without losses every horse-power applied to the dynamo would produce 746 watts, and every 746 watts put into the motor circuit would develop one horse-power. But all machines have friction, all wires have resistance; and there are iron losses in the armature cores. All these losses mean that a certain amount of energy is transformed into useless heat. Consequently, the foot-pounds per minute represented by the kilowatt output of the dynamo will be less than the foot-pounds per minute applied to the dynamo shaft, and likewise will be greater than the foot-pounds per minute developed by the motor shaft.

We saw that heat energy is stated in thermal units, and we see that electric energy is stated in watts. Thermal units and watts are both measured in foot-pounds. We have, then, a common measure for the energy consumed by the steam locomotive and for the energy consumed by the electric locomotive. The electrical expression—watts equals the product of the current by the volts ( $W=C \times E$ )—is but another way of saying that so many foot-pounds of work are done per minute. If the motor is doing 100

h. p., we know that the dynamo is doing more than 100, and that the steam engine is doing still more than the dynamo—enough more to take care of the friction of the engine itself and the losses in the dynamo, line and motor. We can measure the current and volts, and so can know exactly how many foot-pounds are applied to the motor, for, as stated, 746 watts equal one horse-power, or 33,000 foot-pounds per minute. In fact, we can measure the foot-pounds per minute delivered to the furnace, to the engine, to the dynamo, to the line, to the locomotive and to the train. All these foot-pounds means heat units. Watts meaning foot-pounds and foot-pounds meaning heat units, we have, of course, a measure of the heat generated in the circuit in overcoming resistance of the wire. We can measure the current in the wire and can measure the voltage required to drive this current through the resistance of the wire. The product of the current by the volts gives the watts lost in the wire. These watts translated into foot-pounds, and these foot-pounds translated into heat units, put the line loss in terms of coal pile—terms which are not difficult to understand.

#### HEATING EFFECT OF CURRENTS.

We know from experience that current heats the wire that carries the current. Silver is the best conductor, but its resistance is so little different from that of copper that copper is the metal that is generally used. I just pointed out that the heat generated per minute in the wire can be translated into foot-pounds per minute, or horse-power, or watts. Watts, as stated, means the product of the current by the volts; consequently, we can then find the volts required to drive the particular current through the particular wire under consideration. I also stated that a pressure of one volt would drive a current of one ampere through a resistance of one ohm. Ampere will, perhaps, mean more to you if you will bear in mind that current is used for electroplating, and that one ampere will deposit a certain weight of silver per second. Such an arrangement has been used as an ammeter. Ohm will mean more to you if you will think of it as being the resistance of a copper wire 1000 ft. long and 0.1 in. in diameter. The volt, then, is the pressure used in driving an ampere of current through the 1000 ft. of copper wire 0.1 in. in diameter.

If we had 10,000 ft. of this wire we would have 10 ohms resistance, and as one volt is used in driving one ampere through each 1000 ft., why 10 volts, of course, will be required to drive one ampere through the 10,000

feet. The power will be the product of one ampere by the 10 volts—10 watts. If we had 100,000 ft. of such wire we would have 100 ohms resistance and, consequently, 100 volts would be required to drive one ampere through it. If the wire were insulated and we connected one end to the positive brush of a 100-volt dynamo and the other end to the negative, one ampere would flow through the wire. The product of the current by the volts would be 100 watts. The wire would weigh 3150 lbs. One hundred watts are converted into heat in this wire every second. This is not very much, just twice as much as that given out each second by one 50-watt lamp. Suppose we had used a 1000-ft. length. Its resistance would be one ohm, consequently, the 100 volts would drive 100 amperes through it. One hundred amperes by 100 volts means 10,000 watts, or 13.4 h. p., or 7370 foot-pounds per second, or 9.4 heat units. The weight of copper is 31.5 lbs. If the current flowed one second the temperature would rise 3.3° F. Suppose we had used 100 ft. The resistance would have been 0.1 ohm and the current 1000 amperes until the wire melted. Had 10 ft. been used an explosion would have followed, for the resistance of 10 ft. is 0.01 ohm, and the machine would attempt to drive 10,000 amperes through the wire. If the steam engine were powerful enough and the dynamo heavy enough, the energy expended in one second would have been 1,000,000 watts, or 1340 h. p., or 737,000 foot-pounds, or 940 heat units. The 10 ft. of wire weighs 0.315 lbs. The heat generated would be sufficient to raise the temperature of 10 such wires 3000° F. The single wire, of course, would vaporize instantly. This energy translated into motion would raise one of the tunnel locomotives three feet. We see, then, the practical necessity of keeping the heating within proper bounds.

Tables have been compiled giving the safe carrying capacity of wires, and fire insurance companies are very strict in their rules on the subject. We saw that a copper wire of 0.1 in. diameter could carry 10 amperes with practically no heating. If we want to carry 20 amperes we can use two such wires in parallel. If we want to carry 100 amperes we can use a cable made up of 10 strands of such wire, or can use a single wire of an equivalent cross-section. The proper cross-section for the various currents has been determined by experience.

We see from the above the current depends upon the resistance of the circuit and the voltage applied to the circuit. If we keep the resistance constant and increase the voltage, why

the current increases. If we keep the voltage constant and increase the resistance, why the current decreases. The expression is current equals volts

$$\text{divided by resistance, of } C = \frac{E}{R}$$

(here E stands for volts). From the wire tables we can pick out the resistance of any wire. Consequently, if we know the voltage that is applied to the particular length of the wire, we can find the current which that voltage will drive through the wire.

$$\text{Now, since } C = \frac{E}{R}, \text{ we can multiply}$$

$$\text{both sides by } R \text{ and get } C R = \frac{E \cdot R}{R}$$

Canceling out the R's on the right hand we get  $C R = E$ . The expression means that the product of the current by the resistance equals the voltage required to drive the current through the resistance. Consequently, if we know the resistance of a wire, and know how much current we want to send through the wire, we can find the voltage required to drive the current through the resistance.

$$\text{If we divide both sides of our last expression by } C, \text{ we get } \frac{C R}{C} = \frac{E}{C} = R.$$

This means that the resistance of a wire equals the volts applied to it divided by the current flowing through it.

These three expressions are but variations of ohms law, which, in its simplest form, is that one volt will drive one ampere through one ohm. If we know any two of the quantities we can find the third. It enables us to figure the loss in a transmission line. We want, for instance, a certain number of horse-power delivered at a certain distance from the power-station. Horse-power means so many watts. Watts means so many amperes at so many volts. We can find the size and resistance of the line wire from the wire tables. The line resistance multiplied by the amperes gives us the volts absorbed in driving the current through the line. The product of these volts (lost in the line) by the current gives the watts lost in the line. These watts are spent in heating the line wire. The generator therefore must supply these watts in addition to those it delivers to the motor. The heavier the copper wire used in the line, the smaller the percentage of the total power wasted in the line. If we wanted to transmit power at 500 volts with a 10 per cent. loss, we could only allow 50 volts drop in the line. If we wanted to transmit it at 50,000 volts with 10 per cent. loss, we could allow 5000 volts drop. One thousand kilo-

watts at 500 volts means 2000 amp., while 1000 kw. at 50,000 volts means 20 amperes. Our line resistance in

$$\text{the first case would be } R = \frac{E}{C} = \frac{50}{2000} =$$

$$0.025 \text{ ohm. Our line resistance in the second case would be } = \frac{5000}{20} = 250$$

ohms. The wire in the first instance would have to be about one square inch in cross-section, and the power could be transmitted about one-quarter of a mile with 10 per cent. loss in the line. The copper would weigh about 8000 lbs. In the second case, the same weight of wire 0.1 in. in diameter could be used and the power transmitted 25 miles with the same loss. In fact, power is transmitted more than twice this distance with this voltage.

$$\text{Ohms law } (C = \frac{E}{R} \text{ or } C R = E, \text{ or}$$

$$R = \frac{E}{C}) \text{ and the expression for watts}$$

( $W = C E$ ), and the relation of watts to horse-power (746 watts=one horse-power) and the foot-pounds per minute in a horse-power (33,000 foot-pounds per minute=one horse-power) and the foot-pounds per heat unit (778 foot-pounds=one heat unit) enable us to figure not only the line losses, but the energy consumption of the electric locomotive as well, and figure it in the same terms that we measure the energy consumption of the steam locomotive. We start with coal in both cases and end with draw-bar pull in both. The passage of the energy through the electric form introduces additional losses, but since we know how to measure energy in the electric form, means have been found to minimize the electric losses to such an extent that they are but a small percentage of the total losses.

TRANSFORMATION OF ENERGY.

As a result of your scientific reading you know that energy can be transformed but cannot be destroyed. The evolution of this idea is the achievement of modern science, and is one of the greatest generalizations ever made. The law is applied to all problems involving the transfer of energy in any of its forms, and if the result cannot balance the energy equation, why the result is not valid. Knowing then that a certain number of heat units should produce a certain number of foot-pounds, and knowing how to measure the heat units and foot-pounds, we find that Nature charges a commission for every transformation, and we can find out just how much she charges. It is the busi-

ness of the engineer to minimize these losses. Let us glance at the more important ones in the case of the locomotive.

The heat units in the coal are stored energy from the sun, and, as pointed out, they represent a certain number of foot-pounds of work. By burning the coal we have a means of transferring some of this stored energy to the steam and by allowing the steam to expand we can transfer some of the steam energy into motion. By the means of a prony brake we can measure the power developed by the engine. Knowing the temperature of the steam and its pressure, and the weight of the water of condensation, we can measure the energy supplied to the engine. We can measure the losses in the steam line due to radiation, condensation and wire drawing. We can measure the heat carried off by the flue gases, the losses due to boiler and furnace radiation, the losses due to imperfect combustion and the losses due to wasted fuel. Now, according to the law of the correlation and conservation of energy, we know that the foot-pounds developed by the engine plus the foot-pounds lost in the transformation and transmission must equal the foot-pounds represented by the coal consumed. We have just seen that we can measure the work done by the motor, and the energy consumed by the motor, also that we can measure the line losses and the output of the generator. The output of the steam engine is expended in the dynamo. The work done by the motor, plus the losses in the motor, line and dynamo, equal the work done by the steam engine. Consequently, the work done by the motor plus the whole chain of losses equal the energy stored in the coal that was consumed in doing the work. I stated that these various losses can be measured. Now, measurement shows that the losses due to the electrical transformation are small compared to the losses in the steam end. For instance, a 1000-h. p. engine that can transform 20 per cent. of the energy supplied to it into motion represents about the best the art can produce; but an electric motor of the same capacity can transform 95 per cent. of the energy supplied to it into motion. The balancing of the energy equation then tells us that the addition of an electrical transmission system to a steam plant means but a slight increase in the losses. It also shows us that by centralizing the steam plants, by using improved methods of steam generation and by employing electrical transmission, we can do the work more economically than by applying the ordinary steam engine directly to the work. It is not surprising, therefore,

that the electrical locomotive is encroaching in the tunnel work and terminal work of the steam locomotive. Now, the essence of the electric locomotive is the series motor. But before considering the motor, however, I want to call your attention to a simple transmission system.

We will assume two similar, but widely separated magnetic fields (see Fig. 24). We will assume that there is a wire in each field parallel to the current that produces the field. We will assume further that the wires are the same length, that they are similarly situated and that the front end of the first wire is connected with the front end of the second wire, and that the rear end of the first wire is connected to the rear end of the second wire. Now, if we apply a prime mover to the first wire and force the wire in parallel to the axis of the field, we will find that the second wire moves in also. Moving in the first wire cuts lines of force. The cutting sets up a voltage which drives a current through the circuit, say, from rear to front, in the first wire. A certain force is exerted in moving the wire for it is the case of making parallel currents of opposite direction approach. In the second wire it is the case of parallel currents of the same direction. Consequently, as the same current is flowing in similar fields, the second wire, as it closes in, exerts the same force that is exerted in the first wire. The second wire will, for instance, lift a weight equal to the force exerted in the first wire. The faster we move in the first wire the faster the second wire will move in. But the second wire will not move quite as fast as the first, for while moving in it cuts lines of force, and if it cuts at the same rate as the first wire it would generate an equal voltage and no current would flow. Now, the current that actually flows is equal to the difference in voltage generated by the two wires, divided by the total resistance of the circuit. The difference between the energy spent in the first wire and the energy developed by the second wire is the energy lost in the transmission. The steam engine forces the wire across the dynamo field. The line current drags the wire across the motor field. So much for the simple transmission system. We have already considered the motor and the dynamo. I will now call your attention to the particular type of motor that is used on the electric locomotive, which, as stated above, is the series motor.

#### SERIES MOTOR.

The striking thing about the series motor is that it gives the electric locomotive the characteristics of the steam

locomotive. I pointed out that a steam locomotive exerts a light pull at high speed on a level track, a heavy pull at moderate speed on an up-grade and powerful pull when starting a train. Now, the series motor behaves in the same way. Its characteristics result naturally from the relation of torque to current and the relation of speed to voltage. When we were discussing torque and speed we assumed the motor to have a separately excited field of constant strength. We assumed the field current to be drawn from a battery. Now, in a series motor the field winding and the armature winding are, as the name indicates, in series (see Fig. 25). Consequently, the current that produces the field also makes the armature rotate. We see, then, that any variation in the armature current produces a variation in the field strength. I pointed out when discussing torque that doubling the armature current in a constant field doubles the torque, also that with a constant-armature current, doubling the field strength also doubles the torque. Now, if the armature current and the field strength are doubled at the same time, why we get, of course, four times the torque. Well, something like that takes place in a series motor. The motor could be so designed that doubling the current would give four times the torque, and trebling the current would give nine times the torque; but it is not so designed, for such a design would require an excessive amount of iron in the magnetic circuit. The relation is true for the light currents, but the ratio magnetism to current falls off as the current gets heavier.

We will, for simplicity, neglect the tendency of the iron to approach saturation as the magnetizing current increases, and will assume that doubling the armature current doubles the number of lines in the field. We will assume also that the motor is running on a 500-volt circuit and that before the current changed the speed was about 500 r. p. m. The armature was probably generating about 490 volts. Now, if the armature speed did not change when the field strength doubled, why the armature would generate about twice its former voltage. But the speed drops, of course. It drops to a point where the armature generates less than 500 volts. Consequently, it will drop to at least one-half its former speed. But in order that double the current may flow the armature must generate less voltage than formerly, consequently, the new speed will be a little less than half the former. Likewise, if three times the current gives three times the field strength, why the speed would drop to a little less than one-third the form-

er speed for this current. Also, had the current been cut down to one-half the speed would have more than doubled. In general, the characteristics of the motor are such that with a light current the armature speed is high and the torque small, and with a heavy current the speed is low and the torque great. We see, then, that the series motor will run fast on the level track, where a small torque is required, and will run slow up a grade, where a heavy torque is required.

Assuming that doubling the current gives four times the torque and halves the speed, it follows that when the motor encounters a grade that calls for four times the torque, it only takes double the current from the line. Now a constant-speed motor would take four times the current to give four times the torque, consequently, would take four times the power, or twice as much as the series motor takes on this grade. The series motor adopts its speed to the grade. The constant-field, or shunt motor, as it is called, tries to run up all grades at the same speed that it runs at on the level track, which means excessive currents on heavy grades. Under the conditions we have assumed, if nine times the torque were required, the series motor would only take three times the current, while the shunt motor would take nine. We see, then, why the series motor is adapted to grade conditions.

When discussing the steam locomotive I pointed out that the greater the draw-bar pull exerted in starting a train, why the quicker the train gets up to speed. Suppose that nine times the normal draw-bar pull is required to bring the train up to speed in one minute. Assuming that three times the normal current will give the series motor nine times the normal torque, it follows, in this case, that we can start the train with three times the normal current. Had a shunt motor been used, why nine times the current would have been required. However, as stated above, the series motor is not designed to give nine times the torque with three times the normal current. The three-fold current can give, nevertheless, from six to seven times the normal torque.

Now, while it is true that the series motor is by far more economical of power in starting than the shunt motor is, it is also true that even the series motor wastes some power when starting on a direct-current circuit. I pointed out that when the power is thrown on the only thing that stops the first rush of current is the ohmic resistance of the circuit. The standard railway voltage is 500 volts. Assume the ohmic resistance of a 125-h. p. motor to be 0.1 ohm. Now, if

the motor without any additional resistance were thrown on a 500-volt circuit, why 5000 amperes would start to flow. Assuming that the motor current must not exceed 500 amperes, we see that there must be one-ohm total resistance in the circuit at the start. Consequently, 0.9-ohm external resistance must be inserted. This external resistance is called the starting rheostat. Until the armature begins to rotate all the energy is transformed into heat, and 90 per cent. of this waste takes place in the rheostat. But as soon as the current begins to flow through the armature, the armature begins to revolve and generate a voltage. As it gathers speed its voltage increases. By the time it is generating 100 volts, the effective pressure is 500 minus 100, or 400 volts; consequently, if we want to keep the current at 500 amperes we must cut down the total resistance to 0.8 ohm. We do this by eliminating a part of the external resistance. By the time the speed has reached the point that the armature generates 200 volts, the unbalanced pressure has been reduced to 300 volts. Consequently, to keep the current at 500 amperes the external resistance must be cut down to 0.5 ohm. The speed keeps on increasing, and by the time it has reached the point where the armature generates 400 volts, the unbalanced pressure is only 100 volts. Consequently, the external resistance must be cut down to 0.1 ohm. When the further increase in speed brings the voltage up to 450 volts, why all the external resistance will have to be cut out to allow 500 amperes to flow. If the speed rises to the point that the armature generates 475 volts, the unbalanced pressure is 25 volts. This will only drive 250 amperes through the motor resistance of 0.1 ohm. Consequently, the torque will, according to our assumption, only be one-fourth as great, and the speed will now increase at one-fourth its former rate. By the time the armature voltage has reached 490 volts, the unbalanced pressure is only 10 volts. This will drive 100 amperes through the armature. We will assume that the torque has now fallen to a point where it is only able to overcome rolling friction of the train, consequently, no further increase in speed will take place. A balance has now been attained, so the motor runs on at a constant speed.

During all the time external resistance was in the motor circuit, energy was being wasted in this external resistance in the form of heat. In practice, these losses are reduced by using motors in pairs, starting with the two motors in series and throwing them in parallel when half the line voltage is attained. Nevertheless,

there is considerable waste even with this series parallel arrangement.

We see from the foregoing why an electric locomotive equipped with series motor has the same speed and draw-bar characteristics as the steam locomotive, and why the electric locomotive also has its losses. However, the electric locomotive as a machine for transforming electric energy into motion is 15 times more efficient than the ordinary steam locomotive is when considered as a machine for transforming heat into motion. As a machine, the electric locomotive is simpler than the steam locomotive. The main problem is to get the power to it. A practical solution of this problem where a distance of a few miles is involved has been found for direct-current work. Long-distance work involves alternating current. However, before considering the alternating-current motor I will direct your attention to the relative efficiency of the steam and electric locomotive.

#### ELECTRIC LOCOMOTIVE *vs.* STEAM LOCOMOTIVE.

I have pointed out that the steam locomotive is neither an efficient steam producer nor an efficient steam user, but that the modern steam plant is both. The modern steam plant can produce a horse-power hour with half the coal that the average steam locomotive takes to produce a horse-power hour. The addition of an electric traction system to such a plant need not add more than four per cent. to the total losses. Consequently, the electric locomotive fed from such a station practically applies the station efficiency to locomotive work. This means that the electric locomotive can do about twice the work of the steam locomotive with the same weight of coal.

Take an example. A good steam locomotive burns on an average five pounds of coal per horse-power hour. Good coal contains at least 12,000 heat units per pound. The five pounds then represent 60,000 heat units. But the conditions under which steam is generated on the locomotives are so unfavorable that only about 53 per cent. of the heat units get as far along as the locomotive cylinders. Now the locomotive must be able to run at various speeds, and must be able to give various draw-bar pulls. Consequently, a high steam-engine efficiency under such variable conditions is out of the question. In fact, the locomotive does not deliver to the train more than eight per cent. of the energy that finds its way into the cylinders. We started with 60,000 heat units in the coal. Fifty-three per cent. of these, or 31,200, get as far as the cylinders. Eight per cent. of these, or about 2500

heat units (approximately one horse-power hour), are actually transformed into train motion. This means that 67,500 heat units, or more than 95 per cent. of the original 60,000, have been lost in the transformation. In other words, a little more than four per cent. of the energy stored in the coal is transformed into useful work by the steam locomotive.

Now assume that we burn 2.5 lbs. of the same coal in a modern power-station. The 2.5 lbs. of coal contain 30,000 heat units. In the modern power-station the design of the furnace and boilers, and the lay-out of the feed-water system and steam lines are such that 72 per cent. of the heat in the coal can actually reach the engine. The design of the engine is such that 17 per cent. of the energy delivered to it can be transferred to the dynamo. The losses in the dynamo, in the transmission system and in the locomotive

can be held below 30 per cent. of the total power supplied to the dynamo. We started with 30,000 heat units. Seventy-two per cent. of these, or 21,600 heat units, reached the steam engine. Seventeen per cent. of these, or 3,670 units, reached the dynamo. Seventy per cent. of these, or 2,570 heat units (approximately one horse-power hour), appear as train motion. This means that 27,400 heat units, or approximately 91 per cent. of the 30,000 with which we started, are lost in the transformation. The output of the electric locomotive, then, is a little less than nine per cent. of the energy stored in the coal. The output of the steam locomotive we saw to be a shade over four per cent. of the energy stored in the coal. Both of these efficiencies are bad enough, but you will note that the steam locomotive takes twice as much coal per horse-power hour as the electric locomotive. You

will note, further, that the electric losses were 1100 out of a total of 27,400. In other words, 96 per cent. of the losses are chargeable to the steam and four per cent. to the electric end.

The total fuel bill for all the roads in the United States is, of course, enormous. According to the records it was more than \$150,000,000 in 1905. In fact, it is between 10 and 11 per cent. of the total operating expense of the roads. Now, if the fuel bill for an important service can be cut in two by the substitution of the electric locomotive for the steam locomotive, why the electric locomotive will eventually receive the serious attention of the railway managers. The fuel bill, of course, is not the only consideration, but it is an important one. It is a measurable quantity. It is the one with which we are directly concerned.

*(To be continued.)*

## Electric Motor Connections

The single-phase induction motor, manufactured by the General Electric Company, is wound as a three-phase motor, with a squirrel-cage rotor. It is obviously impossible to start such a motor directly from a single-phase line. If it is once started in either direction by any means whatever, and brought up to nearly synchronous speed, the motor will continue to run in that direction if connected to a single-phase line.

In order to bring the motor up to speed, the General Electric Company

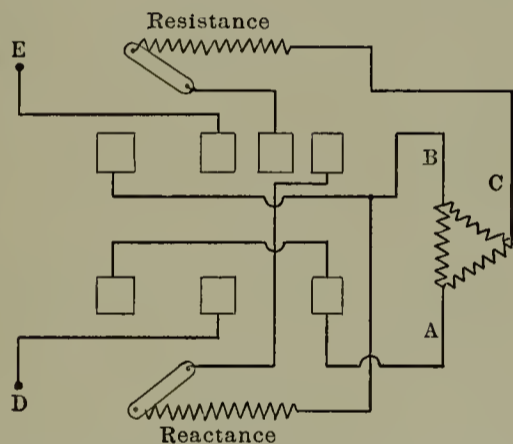
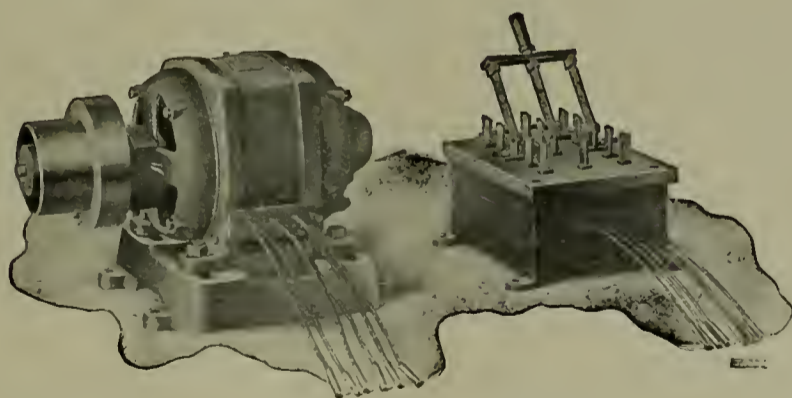

DIAGRAM OF CONNECTIONS FOR SINGLE PHASE INDUCTION MOTOR.

the phases are not regular, there is a definite phase rotation.

As the machine reaches synchronous speed, the switch is thrown to the up position, which puts the motor directly on the line, at the same time cutting out the resistance and reactance.

In many cases, both resistance and reactance coils in the starting box are divided into several parts, so that if the machine fails to start readily with all the resistance and reactance in, it is quite easy to change the connection,



5-H.P. TYPE IS FORM KG MOTOR.

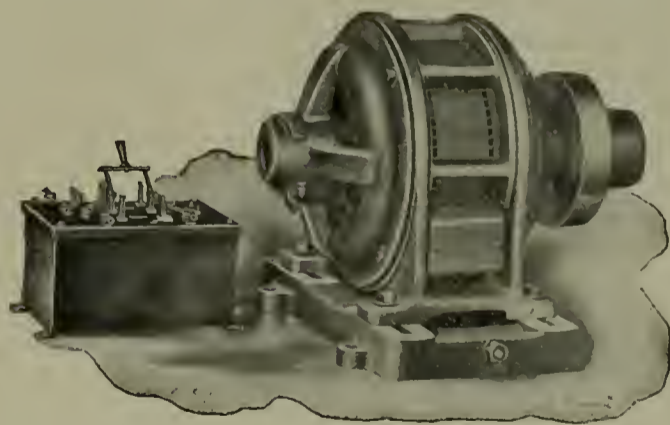

10-H.P. TYPE IS FORM KG MOTOR.

makes use of a device founded on the principle of splitting the phase by means of resistance and reactance in the line. The starter consists of a double-throw switch which inserts a resistance and reactance in circuit. This changes the single-phase current roughly into three-phase, which is applied at the three terminals of the motor, as, for example, at A, B and C in the accompanying diagram. While all

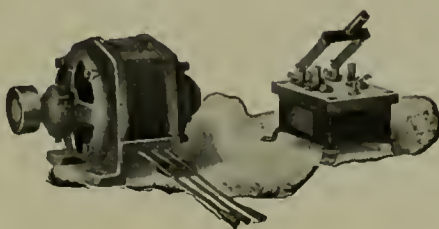

1/2-H.P. TYPE IS FORM KG MOTOR.

thus cutting resistance and reactance out of the line.

In order to enable these motors to start heavy loads, a slip pulley has been devised. This pulley runs loosely on the motor shaft, allowing the shaft to turn freely in the pulley while the motor is being started. As the motor comes up to speed a centrifugal clutch, which is keyed to the shaft, grips the inside of the pulley, making the motor gradually pick up the load.

# SELLING CURRENT

Copyright, 1907

## The History of Electric War in Toledo

C. N. JACKSON

Formerly Commercial Manager of the Toledo Gas, Electric and Heating Company

I then classed my solicitors into groups, each group to solicit the class of business best suited to him. The newest men were put on residence lighting, as I was working the same plan on residences. After he had made good at that work, I put him on apartment houses, then on small business houses, and, finally, on the larger ones. I reserved the big stores, hotels and office buildings for myself. I finally had sixteen men of all grades and ability. I appointed one man who had proved his worth to take charge of the residence and apartment house solicitors, and another to take charge of all business-house solicitors. I had one power solicitor who worked directly under my supervision.

Every user's card had a serial number. We also had a corresponding serial number in a book. When I gave a solicitor a bunch of cards he was charged with those cards. When he returned one, the name was erased from the book. If he had not secured the contract, and couldn't get it, the card was given to another. In that way we never let go until we had the contract.

My plan was to secure every contract possible before we started to run our feeders into the business district, because the Toledo Railways and Light Company could not do a thing to stop us. Sometimes we closed the contract at the first visit, but generally the user would put us off and call on the Railways and Light Company and ask for a lower rate. Of course, they couldn't begin to cut rates one year and a half before they thought we would be able to give service, so they would naturally refuse and then it was easier for us to get his contract.

In the meantime, the engineering department was rushing their work in an almost phenomenal manner. The day the money was paid for the Toledo Heating and Lighting Company, the consulting engineer commenced work. The architect had the plans for the new power-house all ready for the builder, who was ready to start to work.

The three-conductor feeders were ordered and a contract was let for

two 1000-kw. three-phase Westinghouse turbines, as it would require four or five months to deliver one. As it was necessary to have something to carry our winter load, our plan was to get our feeders into the business district and give service by December 1st (it was then about September 1st), the Westinghouse Company loaned us a two-phase 180-kw. turbo-generator, on which we got an immediate delivery.

The construction of our feeders progressed more rapidly than our competitors figured on. The Toledo Home Telephone Company was practically controlled by the same men who controlled the Toledo Gas, Electric and Heating Company, and it was a very easy matter to lease a few empty ducts from them; consequently, there was very little to do except run a pole line in a few places. About November 20th we were giving service in the heart of the business district. We had over one thousand contracts written and were in a fair way to get our share of the business. We had to be very careful and not overload our 180-kw. turbo-generator, which we connected in a very unique manner so as to get the full capacity on our three-wire circuit. Of course we could only furnish single-phase service with that connection, so we could not connect any large motors. During December we watched the generator very closely and every day we would connect up a few more small users, though we would not take chances on the big users. At times we ran the machine at 150-per cent. load and had no trouble whatever. In fact, that little generator ran four or five months 24 hrs. per day and never stopped once.

Until about November 1st everything went even better than we ever hoped for, but then our troubles began. Unfortunately, the manager had never been in such a turmoil before and the strain was too great for him. When word was passed to connect up every small user as soon as possible, we found that we had no meters, and none ordered, consequently, connections were made without meters. The manager said we could approximate bills.

The force for making connections was so small that they could not keep up with the contract department, let alone gain on the one thousand contracts which were already made. The

connecting force were greatly handicapped because they worked directly under the consulting engineer, who was in Toledo sometimes once a week for a day or two. No one but the consulting engineer had authority to buy anything, and I have seen the connecting force loaf for several days because they were out of wire or fuse blocks or some other small necessities. The connections were so slow that I made a strenuous fight to get them to employ a superintendent who could be in touch with the men every hour in the day. This they finally did, and went to the extremes by employing a man who had no practical experience in such matters, who made matters worse, if such were possible.

This condition existed until spring, when we installed our first 1000-kw. three-phase turbo-generator. Then the trouble began in earnest. We had run our high-tension 4600-volt feeders through trees, regardless of consequences. Every time a mist would fall, so would a few feeders. The contracting force would leave an innocent boy to answer the complaints, and the rest would "hide out."

Fortunately, I had not allowed them to connect any large users, so we only got a large number of complaints from small users. Upon investigation we found our high-tension lines in a very poor condition. They were run through the thickest foliage on a tree, and the trees in Toledo are very numerous. The reader can imagine the trouble we had when I have seen a feeder burned off by coming in contact with a twig about the size of a lead pencil; that twig was 12 ft. away from the feeder, but the tree was blown toward the feeder and the feeder was swinging so that they finally touched.

After this lesson, the company finally employed a good superintendent, who lost no time in employing a professional tree-trimmer, who had a force of men, to trim out the trouble. It was a big undertaking, but by cutting trees and changing the pole lines they finally succeeded in reducing the "burn-outs" to a very satisfactory number.

But our troubles were not over, as the linemen went out on a strike because the foreman was discharged. He was unfamiliar with lighting work, having been on street railway work, and the company wished to replace



him with a man who understood lighting. We were so crippled that for a long time we didn't have enough men to "chase" trouble, and all of our connections were held up again.

During all this time, from December 1st to June 1st, the contract department was "sitting down." I went to the manager and told him we would not make any campaign after contracts until they could be connected with first-class service, because we couldn't get them at a decent rate, as the user, when approached, would go to our competitor, who would show him the names of users who had given us a trial, and had quit us on account of poor service. This would invariably tie him up with our competitor for a year or more.

I argued that if the man were not approached he would be more likely to remain as he was until we could approach him with a safe proposition. Consequently, I discharged nearly all of my men, only keeping two for residence work, one for power and one for small stores. I was to attend to the large users, but I never saw the time when I thought it would be safe to go after them. I had taken a few contracts from personal friends, who made me promise not to connect them until I was sure of giving them un-

interrupted service. Our manager often insisted that they be connected, as he knew the service would be good, but I held them off and always congratulated myself for doing so, as something always happened after that. At one time the manager gave orders to connect a certain hotel against my wishes, and I had to go to the proprietor and tell him not to allow them to do it at that time. It is needless to say that they didn't connect it, and I didn't let them connect it until some time in June when it was safe.

After the company was able to give fairly satisfactory service it went after business with only one idea in mind—"Take it away from the competitor at any price," and the competitor seemed to have the same idea, because the largest hotel that used about 40 kw. on the peak made a contract with the Toledo Railways and Light Company for about \$1,800 per year. I am very certain that the Toledo Railways and Light Company did all the wiring (the hotel was being remodeled and there was a great deal to do), and furnished all lamps and renewals.

The Pope Motor Car Works made a contract with the Toledo Gas, Electric and Heat Company for 500-volt direct-current at about 1½ cents per

kilowatt-hour. The Toledo Gas, Electric and Heat Company furnished a motor generator, and I have been told by one who should know that only the output of the motor generator was metered. I could have secured this contract in September of the year before at 2½ cents for power, but refused it.

When the municipal lighting contract was let in the fall of 1906, the Toledo Railways and Light Company, to be on the safe side, bid about \$45 per lamp per year all night and every night. I do not remember the full particulars, but I do know that they got the contract. Matters went along in that way until last spring, the Toledo Railways and Light Company bought all the stock of the Toledo Gas, Electric and Heat Company, paying for same three shares of their stock for four shares of the Toledo Gas, Electric and Heat Company's stock. The Toledo Railways and Light Company guaranteed the bonds of the Toledo Gas, Electric and Heat Company. The Toledo Railways and Light Company in order to do this increased their capital stock \$2,500,000. That was the capitalization of the Toledo Gas, Electric and Heat Company. It is a common report that the promoters got a bonus of the other 25 per cent. of stock for putting the deal through.

## Questions and Answers

**Any questions our readers may put to us will be cheerfully answered in this column**

*Question.—How shall I arrange to connect to auxiliary power service in case our plant breaks down?*

*Answer.—Use a two-pole, double-throw switch. The bus bars in this case would be connected to the middle lugs of the switch and the generator connected to the upper lugs with the auxiliary service on the lower lugs.*

*Question.—Our generator is grounded. How can I tell whether it is in the field or the armature?*

*Answer.—First, disconnect the field connections from the terminal block, so that it has no electrical connection with any other part of the machine. Connect one end of the testing apparatus with any part of the iron frame of the generator. Touch the other terminal to either of the free terminals of the field windings. If you get a "ring," assuming a magneto is being used for testing, it indicates a ground in the field circuit. Now disconnect one by one in turn the different field coils until the "ring" is no longer obtained. Evidently the last one discon-*

*nected before the ring stopped is the defective spool. Repairs can then be made with the spool in place, if an inspection shows that the ground is visible and can be reached, otherwise the coil is to be removed and rewound.*

*If, however, the field circuit does not give a "ring" then lift all the brushes from contact with the armature. With one end of the testing circuit still grounded on the iron frame, now rub the other end along the commutator. If a ring results the commutator is grounded. If no ring is obtained it shows the armature is free from grounds.*

*Before connecting up the machine again with the outside leads from the switchboard disconnected from the terminal board of the generator take the free testing wire and touch the cables which connect the brush rigging with the terminal board. If a ring is obtained it will show that the cables are grounded to the frame, either at some point where the insulation has worn off, or at the studs holding up the brush rigging.*

*Question.—I am the engineer operating a steam engine. My employer has lately been securing proposals to install a direct-current dynamo of 150 kw. capacity. Our engine indicates 200 h.p. on the limit of the cut-off, which gives us a small margin for overload. Yesterday the salesman of another company offered a proposal on an alternating-current generator of 180 kw. He told my employer that although he was going to use only 150 kw. he would have to put in the 180 kw. to do the same work as a 150 kw. direct-current machine. As I am responsible for the steam plant I want to know why the size is larger, because if it takes a 180 kw. alternating-current machine to do the equivalent of 150 kw. our engine is not going to be big enough.*

*Answer.—The reason for an alternating-current generator having a normal capacity greater than the direct-current is as follows:*

*In a direct-current generator the voltage rises to its maximum and con-*

tinues at that value until the switches are pulled or the generator shut down. The rate of flow of the current or amperes reaches its maximum value in the first closing of the switches and continues at that value until the end, except as at odd intervals the number of lights or motors is increased or decreased. The energy given out at any one instant consists of a multiplication of the voltage by the amperage at any instant, giving us the watts energy flowing at that instant. In an alternating-current generator, however, the voltage and amperage go from zero to maximum and back again to zero many times a minute, a 60 cycle machine rising and falling 7200 times a minute. If the generator is feeding incandescent lamps the voltage wave reaches its maximum, or peak, at the same instant as the ampere wave, and we get the momentary number of watts by multiplying the two peaks together (volts  $\times$  amperes).

If, however, any electrical device containing a coil is attached to the circuit, such as an arc lamp, motor or transformer, this device will have the effect of so delaying the wave of amperes that when the voltage reaches its peak the ampere curve will be only one-half or three-quarters complete. When the ampere wave reaches its peak the voltage curve will have started to fall. If, for instance, we had been considering a 100 volt, 50 ampere circuit the momentary watts at the top of the peaks feeding the incandescent lamps = 100 by 50 = 5000 watts (5 kw). When feeding the motor when the voltage was at 100 the amperes would only have been at the 30 point so that the momentary energy would be 100 by 30 or only 3000 watts (3 kw.). An alternating-current voltmeter will always read dead-beat the voltage of the peak of the voltage curve, and the ammeter the peak of the ammeter curve, so that in both of the above cases we would always read 100 volts and 50 amperes. We learn however in the first case we had 5000 watts at one instant, and 3000 watts in the second case, voltmeters and ammeters registering same in both cases. A dynamo supplying current would evidently have to supply 5 kw. for the lamps and only 3 kw. for the motors. Suppose, however, that the actual motor load were 5 kw., the same as the lighting load. If it were necessary to obtain 5 kw. output under the second condition and we could only reach a three-fifth point on the ampere curve at the instant that the voltage was 100, evidently we must get an amperage curve larger than before so that three-fifths of its actual peak would give 50 amperes. We would have 100 times 50 or 5000 watts, which is required, but if we have boosted our amperage

wave our ammeter will now register the peak of this new wave at 83.3 amperes ( $50 = 3/5$  of 83).

At the instant the amperes are actually at the 83 peak the voltage will be at 60 volts so that at the height of the ampere wave we have 60 by 83.3 = 5000 watts = 5 kw.

As explained above with the instruments reading only the peak we would have an apparent energy of 100 by 83.3 = 8.33 kw. We have seen, however, that due to power-factor, instead of over 8 kw. we were actually delivering 5 kw. Now an alternating-current generator to feed this circuit would have an 8.33 kw. rating but the engine driving it would only have to be a 5 kw. machine (not counting losses). If a direct-current generator were selected the actual energy delivered would be the same as the apparent energy and a generator of 5 kw. would be selected and the same 5 kw. engine as before would drive it.

Therefore the representative offering the alternating-current proposition submitted would give figures on a 8 kw. generator which would deliver to your system only 5 kw. In the particular case cited, a 180 kw. alternator would do 150 kw. work. On this end of a power plant the first cost is higher. This is offset by the reduced cost of operating an alternating-current motor system, which does away with commutator troubles and frequent attention.

Question.—*We have a 100 kw. alternator installed many years ago with a 5 kw. exciter. We have put on about 25 kw. lighting and have been running underloaded until lately when a large load of motors has been added. My wattmeter shows that my output is 85 kw., and yet my exciter is so hot I can hardly touch it. When the output was purchased the exciter was guaranteed to have 25 per cent. overload capacity. With my alternator underloaded why should the exciter be so heavily overloaded at this point?*

Answer.—If you will read the answer to the question above you will see that the addition of a motor load requires an increase of the ampere wave delivered by the alternator. Quite evidently, therefore, you must increase the ampere wave of the alternator by making more lines of force for the armature conductors to cut through as they sweep past the field poles. We can only obtain this increased saturation by increasing the number of amperes in the field coils. As this increased number of amperes must come from the exciter it is necessary to have an exciter with a capacity sufficiently large for the purpose. As your alternator is underloaded and the exciter overloaded, it indicates that the

exciter now installed is too small to deliver enough amperes at these low power-factors. You should therefore get another exciter of about 5 kw. which you can parallel, or do away with the present one and install one of the 10 kw. If you have 60 kw. of a motor load with the power-factor as low as 65 per cent., not unusual with small motors, you have a load of about 100 k.v.a., or an apparent load of 100 kw., and current of this value surging in your machine without reckoning the lighting load of 25 kw. You have therefore a field current 25 per cent. in excess and your exciter is overloaded by this amount.

Question.—*I am going to wire for two-phase motors on the three-wire plan. How much greater cross-section should the middle neutral have than either of the outside.*

Answer.—About one and one-quarter greater in cross-section than either of the outside wires, that is, it should carry 25 per cent. more amperes.

Question.—*We have both alternating and direct-current in our building. The other day I accidentally connected a direct-current motor to the alternating-current circuit. The motor rotated, but flashed horribly. Why was this?*

Answer.—Any direct-current motor can operate on an alternating-current circuit but only with this severe sparking which you noticed. In a direct-current motor the lines of force travel in one direction. The coils on the armature just under the collecting brushes are in a position where they are momentarily traveling parallel to these lines of force and therefore not cutting them. Without a cutting action no current is being generated in the coils, while the collecting brushes short-circuit them at the commutator. Hence this short circuit does no harm. If an alternating current be applied to the fields so that the coils under the brushes lie in a field which is alternating back and forth rapidly, current will be generated in these coils which will manifest itself in the form of sparking at the commutator. This current will be of fractional voltage but high amperage. In the Westinghouse single-phase type railway motor resistance leads are inserted between the ends of the armature wires and the commutators bars, so as to choke down this local current and neutralize its effect.

You should never connect a direct-current motor to an alternating-current circuit because it will burn up before you can throw off the switch if you have much of a load at the pulley end.

# Review of the Technical Press

## Energy in Wireless Telegraphy

CHARLES A. CULVER.

(Physical Review, September, 1907, p. 200.)

As a result of an investigation of the relative efficiency of several different types of receiving systems when used under various conditions, the author advances reasons for believing that the energy in wireless telegraphy is propagated through the surface of the earth and not by means of a free ether wave.

## Solenoid in Series with Resistance

CHARLES R. UNDERHILL.

(Electrical World, January 18, 1908, p. 140.)

A theoretical article in which the author discusses the design of a magnet intended to operate in series with a resistance comparable to its own value.

## The Self and Mutual Inductances of Similar Conductors

EDWARD B. ROSA.

(Bulletin of the Bureau of Standards, January, 1908, p. 301.)

A discussion of current formulæ in use with the derivation of a number of new expressions of value in technical work.

## Plain Talks on Illuminating Engineering

E. L. ELLIOTT.

The Illuminating Engineer, January, 1908, p. 795.)

The cost of maintenance for 1000 spherical candle-power hours is given as follows:

Arc lamps (enclosed)... ½ to 1c.  
Carbon filament electric lamps ..... 3 to 6c.  
Metallic filament electric lamps ..... 4 to 20c.  
Nernst lamps..... ½ to 1c.  
Incandescent gas lamps... 2 to 5c.

## Reinforced Concrete Chimneys

SANFORD E. THOMPSON.

(Cement Age, January, 1908, p. 62.)

According to the author about 400 chimneys of reinforced concrete have been built since 1898, and the large majority of them have given satisfaction to their owners.

## Present Status of Incandescent Lamps

J. M. ROBERTSON.

(Proceedings of the Canadian Electric Association, 1907.)

The most valuable part of the paper is the tabular statement of the relative cost of operating different series street lighting systems.

## Electric Power in Coal Mining

(Cassier's Magazine, January, 1908, p. 356.)

A comprehensive and well-illustrated article dealing with pumping, winding and coal cutting.

## Three-Phase Single-Phase Transformations

W. S. MOODY.

(General Electric Review, January, 1908, p. 83.)

It is impossible to take single-phase power from a quarter-phase or a

three-phase system. In the former the power delivered changes from maximum to zero and back to maximum every half cycle; whereas, in the latter the rate of power delivered is constant. Therefore, any system, if it be capable of transforming from balanced polyphase current to single-phase current, must be capable of storing up energy during the interval of time when the power delivered to the single-phase is less than the power received from the three-phase side. The static transformer is incapable of storing any energy and cannot be used for this purpose.

## Electric Welding

C. B. AUDEL.

(The Electric Journal, January, 1908, p. 18.)

The author describes a novel use of electric welding for the repairing of defective castings by melting iron in a carbon arc made at the point which is to be repaired, the arc being made from a carbon stick to the casting which melts at the point of application of the carbon. The table gives an idea of the data for an average welding:

Line Volts	Amperes	Volts Across Rheostat	Volts Across Arc, Including Carbon
126 (open circuit).....			
102.....	550	38	63
102.....	500	36	65
102.....	550	39	61
98.....	600	42	53
97.....	650	44	51
97.....	650	45	50
102.....	600	42	58

Time of weld=56 seconds. Hole filled=1¼ in. diameter by 2 in.—approximately. Size of carbon=1¼ in. by 6 in.

## Westinghouse Reorganization Plan

A plan for the reorganization of the Westinghouse Electric and Manufacturing Company has been practically perfected by the reorganization committee. The plan in its general outlines has been adopted by the unanimous vote of the members of the committee, but is still subject, before its adoption, to the consent of noteholders and bondholders and to the raising of \$7,000,000 from George Westinghouse and his associates by the sale of stock to them.

The principal provision of the plan contemplates the creation of a first mortgage bond issue of \$45,000,000, to bear interest at 5 per cent. Of the entire issue \$18,500,000 will be convertible bonds and be offered in

exchange for the \$18,500,000 outstanding convertible 5 per cent gold bonds. The remainder will be without the conversion privilege and will be utilized to pay off the floating indebtedness and outstanding short-term notes and debenture certificates.

According to the report of Haskins & Sells, certified accountants, the company had on the date of the report a floating indebtedness of \$14,000,000. It is proposed to fund most of this indebtedness by offering to creditors the new bonds, dollar for dollar, for their claims. Similarly, holders of the \$1,969,000 debenture certificates, of the \$6,000,000 6 per cent collateral notes due August 1, 1910, and the 5 per cent French loan due October 1, 1917, are to be asked to exchange these securities, dollar for

dollar, for the new bonds. The floating and funded indebtedness of the company amounts to between \$43,000,000 and \$44,000,000.

In order to provide working capital, the plan contemplates the sale of \$7,000,000 stock at par. It is understood that George Westinghouse and his associates have agreed to take this stock, or at least such portion of it as is not desired by stockholders. According to the terms of the plan it is understood that the raising of the \$7,000,000 is to be effected without anything resembling an assessment on the stock. There is now outstanding \$4,000,000 preferred stock and \$24,000,000 assenting stock. The new stock will be of the latter class.

The committee that has been in charge of the plan consists of Richard

Delafield, president of the National Park Bank; James N. Jarvie, chairman; Albert H. Wiggin, vice-president of the Chase National Bank; Paul M. Warburg, of Kuhn, Loeb & Company; F. H. Skelding, president of the First National Bank of Pittsburgh; Charles A. Moore, of Manning, Maxwell & Moore; Neal Pantoul, of F. S. Moseley & Company, of Boston, and A. G. Becker, of Chicago.

#### A New Recording Millivolt Meter and Shunt Ammeter

Electrical engineers have long felt the need for an accurate and sensitive recording millivolt meter which is adapted to practical every-day service as well as for laboratory tests. There has also been a demand for a recording ammeter of the shunt type which can be connected by leads to the main bus bar. The shunt system



FIG. 1.—RECORDING MILLI-VOLTMETER.

is especially economical where heavy currents are to be indicated or recorded, as the instruments may be located at a considerable distance from the main current, thus saving great expense in carrying the main conductors to the point where the instrument is located.

The recorders illustrated herewith have been designed to meet these particular demands. The two most important fundamental features of these recorders are a sensitive electrical movement of special design, made by the Weston Electrical Instrument Company, and a new recording system using a patented smoked chart so arranged that there is absolutely no friction between the recording arm and the chart.

These instruments are so sensitive that the recording arm will move over the whole scale for five millivolts or less, making it possible to accurately record one ten-thousandth of one volt. The graduations on the chart are evenly proportioned over the entire range,

the same as the Weston ammeter, so that even though there is only a small current flowing, the readings may be as readily taken as if the current was the maximum that the instrument would record. This feature will be greatly appreciated, as there are many places where it is desired to install instruments for increasing future demands, and it is important that the records be perfectly clear, even though the loads are very light when the outfit is first installed.

The records are made on a novel, semitransparent smoked chart, which is periodically brought into momentary

made to operate twice every second. When the record is completed the chart is dipped in a simple fixative solution, which makes the record permanent for filing.

The recording millivolt meter is shown in Fig. 1, and Fig. 2 is a reduced photographic facsimile of a chart taken from one of these instruments in connection with electrolysis surveys of underground structures which are being conducted by the Electrical Testing Laboratories of New York City. The graduations of this chart are arbitrary. It was revolved once in twenty-four hours and

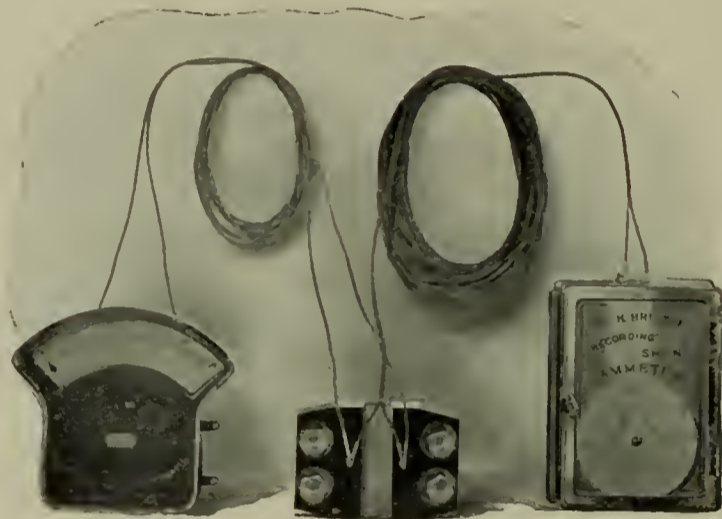

FIG. 3.—WESTON AMMETER AND WM. H. BRISTOL SHUNT RECORDING AMMETER.

contact with the end of the recording arm by means of a special vibrating device. In this way a series of white dots are made on the smoked surface and these form a continuous line and a record is thus made without causing any friction between the moving arm and the chart. The rate of vibration of the chart is timed to suit

was vibrated once every ten seconds. The zero position of the recording arm was the middle of the scale, so that the record might be independent of the direction of the current, as, in many cases, the direction of the current changes from negative to positive during the day.

It is expected that by using a number of these instruments, operating simultaneously at different points, stray currents in water and gas mains, or in any underground structure, may be recorded, making it possible to discover the causes of trouble and how they may be eliminated.

The recording ammeter is shown in Fig. 3 connected to a standard Weston ten-thousand ampere shunt, to which is also connected a Weston indicating station ammeter. This illustration shows that the recorder may be readily applied to any standard shunt which is already in service without disturbing the indicating instrument at the switchboard. As illustrated here, leads of almost any desired length may be used to connect the indicating and recording instruments to the shunt on the main bus bar. It is even possible to have the recording ammeter located in the superintendent's office at a great distance from the shunt and the indicating instrument located on the switchboard convenient for the observation of the operator. Such com-



FIG. 2.—RECORDING MILLI-VOLTMETER CHART.

the frequency and range of the variation in the current to be recorded. The usual period of vibration of the chart is once in ten seconds, but to obtain continuous lines where the fluctuations of the current are quite rapid, the vibrating attachment is

bination outfits could be furnished as units, with leads of the proper lengths to suit the individual cases.

The recording shunt ammeter has been successfully applied for taking continuous records of the current on a large trolley system, where the fluctuations are very rapid, and varied as much as four thousand amperes several times in a minute. The charts for such work as this are made to revolve once in one hour and the vibrator operates twice in one second. For preliminary tests, the recorders are provided with special fast vibrators for the smoked chart and with a clock movement to revolve the chart once in one hour, but for continuous daily records the standard twenty-four hour charts are recommended.

These instruments are manufactured by Wm. H. Bristol, 45 Vesey Street, New York City, who will furnish fuller information to anyone who is interested.

#### New Weston Instruments

A new departure has been made by the Weston Electrical Instrument Company in the production of accurate and yet low-priced ammeters and voltmeters for switchboard work. The direct-current instruments are called the Eclipse type. They work on the "soft-iron" principle, but have been designed after years of investigation to eliminate the disadvantages ordinarily possessed by such instruments. The alternating-current instruments work on similar lines. This is the first alternating-current ammeter produced by this company, it having been found impossible heretofore to construct such an instrument possessing sufficient accuracy. The new instruments are dead beat, very sensitive and are practically free from hysteresis error. They are made in two sizes, one for large and the other for small switchboards. The ammeters are made in sixteen ranges from one ampere to 500 amperes capacity. The voltmeters are made in seven ranges from 75 to 750 volts full scale deflection.

#### The 1908 Cooper-Hewitt Lamp

The 1908 model of the Cooper-Hewitt lamp has a number of improvements which add much to the commercial value of the lamp. The Cooper-Hewitt Electric Company, New York, are the sole manufacturers of mercury vapor lamps, and have incorporated in the new model several

mechanical and electrical improvements as a result of their experience during the last five years.

The general form of the tubes of the several types of lamps remains the same, together with the quality and the high efficiency of the light. The improvements made in the new 1908 lamps are, for the most part, in the auxiliary and the method of installation. The new design makes it possible to handle each lamp outfit as a

joint. Where it is necessary to hang the lamp at some distance from the ceiling, a pipe or conduit of the proper length can be used between the plate and the auxiliary. Where lamps are hung from outlet boxes the ceiling plate can be dispensed with. When desired, the lamp may be hung from a wire rope by screwing a hook to the insulating joint and properly guying the lamp so that it will not swing.

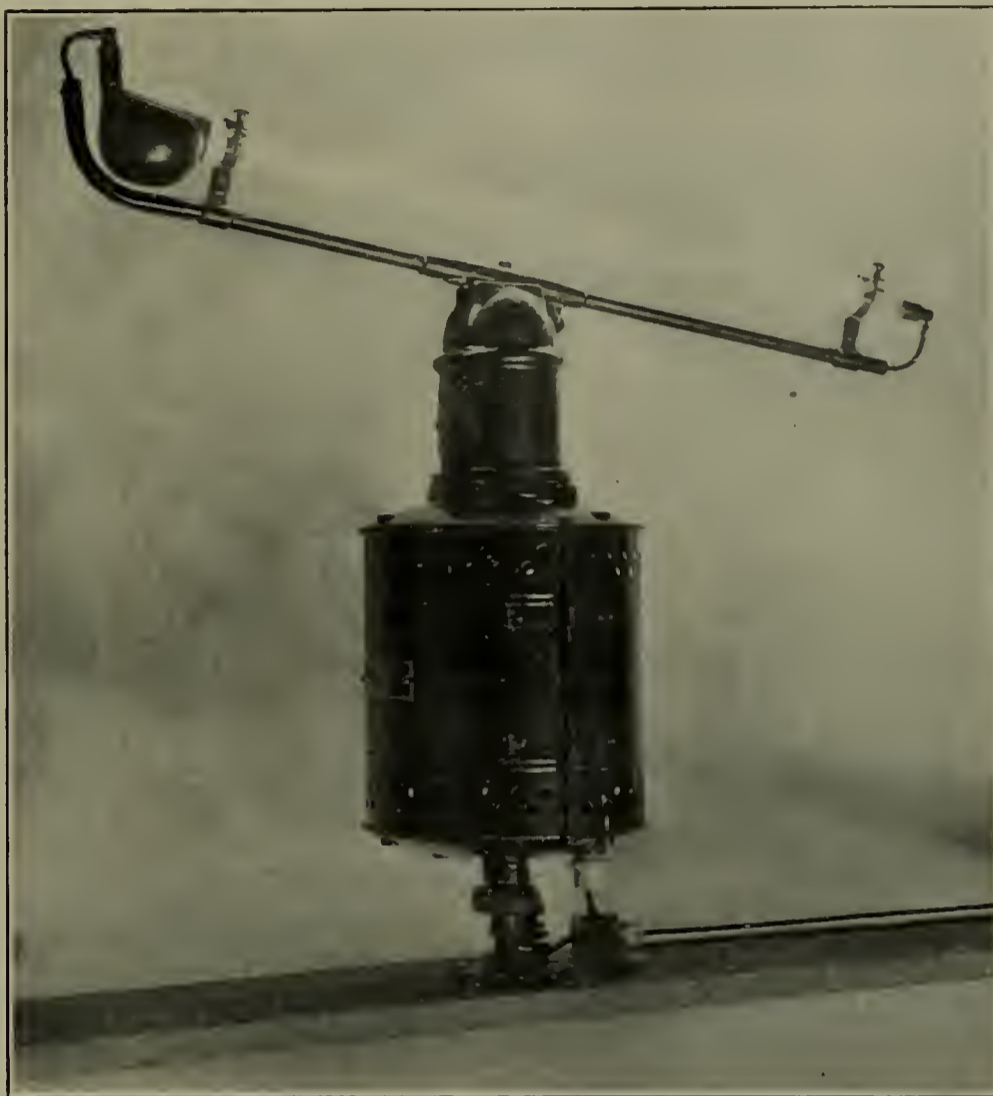

COOPER-HEWITT LAMP 1908 MODEL.

unit, and has greatly simplified the hanging of the lamp.

The parts and functions of the auxiliary to the lamp tube remain the same, and the changes are along the lines of improvement in the manufacture and the assembling of the auxiliary. The new casing of the auxiliary resembles, in a way, the housing of an arc, being cylindrical in form and about eight inches in diameter and 10 ins. high, with the supply lines entering binding posts at the top. The lamp rod, which supports the tube, is attached directly to the auxiliary by a pivot screw.

The hanging and connecting of the new lamp is extremely simple. A ceiling plate, a short-threaded pipe nipple and an insulating joint are furnished with each lamp outfit. These are fastened to the ceiling, and the auxiliary screwed to the insulating

#### The Tungsten Electric Lamp Co.

THE ELECTRICAL AGE takes pleasure in printing the following communication from the newly organized "Tungsten Electric Lamp Co.":

EDITOR ELECTRIC AGE,

45 East 42d St., New York City.

Dear Sir: We, naturally, believe that improvements resulting in bettering the conditions of all, or any portion of the people of this country, should be made known to them.

One of the purposes of electrical magazines is probably to enlighten the readers and to keep them thoroughly informed regarding advancements taking place in the electrical field.

By request of Mr. J. C. Fish, President of the National Electric Lamp Association, we take pleasure in sending you information regarding The Tungsten Electric Lamp Company.

Our object is to aid in having all parties who are, or should be, interested in illumination derived through the medium of electric incandescent illuminants realize the great advancement which will be made in the lighting field by the Tungsten lamp. There is absolutely no doubt as to the success of this illuminant. The most reliable lamp manufacturers in the country know this to be a fact and are financially interested. They are giving their close personal attention to The Tungsten Electric Lamp Company, as well as having hired the best talent in the country to guide this new concern.

The advent of the Tungsten lamp, we think, should be considered a matter of as great importance as the production of the first electric incandescent lamp, the Welsbach mantle, etc.

Yours very truly,  
ENGINEERING DEPARTMENT.

When considering electric incandescent lamps, we must now include the tungsten. This new illuminant bids fair to supersede all others in many places. Its success is guaranteed, if for no other reason than the fact that 16 of the most prominent lamp manufacturers in the country have seen fit to back their faith in it by organizing, under the laws of the State of Ohio, The Tungsten Electric Lamp Co., with a capital of \$100,000. Following are the incorporators: Messrs. G. G. Lockwood, A. C. Garrison, H. B. Vanzwoll, A. S. Terry, L. P. Sawyer, H. H. Geary, J. C. Fish, H. C. Rice, E. H. Haughton, E. W. Gillmer, J. B. Estabrook, W. D. Packard, Wm. Coale, E. J. Kulas, J. E. Randall and T. W. Frech, Jr.

Mr. Frech was elected President and Manager. Mr. Randall is Vice-President and Supervising Engineer. The former has devoted many years to the manufacture of lamps, the latter has been a lamp engineer since 1886, when he filled that position for the Thompson-Houston Co.

These two gentlemen have taken several trips across the Atlantic to thoroughly study the laboratory work being conducted in foreign countries on tungsten lamps, as well as to investigate the methods used in manufacturing them.

Messrs. Frech and Randall have held many consultations with the other members of the Company, and after much experimenting in improving upon the tungsten lamp as produced in other countries. As the carbon lamps in the United States are superior to those made in other lands, so is the tungsten.

The factory of The Tungsten Elec-

tric Lamp Company is located in Cleveland, O. It is 55 by 112 ft., four stories high, with a basement, and fire-proof throughout, concrete cement being principally used in its construction. The total floor area is 30,000 sq. ft. The present capacity is not over 2,000,000 a year, but for several reasons can be increased within a few months.

Tungstens are being made up in 40 and 60 watt-units for multiple service and 40, 50 and 75 watt-sizes for street series work, the amperes on the last three being 4, 5.5, 6.6 and 7.5. The mean horizontal efficiency is 125 watts per c.p.

The Tungsten light is extremely white, and can be used to advantage as a substitute for sunlight when the latter is desired, but cannot be obtained.

#### Belles Letters

THE correspondence of any large company has a general sameness, which is sometimes deadening. One of our large manufacturers received the following, which departed from the usual and brought a smile to the faces of those who handled it:

"Gents in reference to the 5 H P motor i have i had it repaired by a Plumber he soldered the Cylinder on each end and it works all right just now.

"Resp. yours"

The following letter came from a central-station manager with a distinctive ability to put his words into form. It is seldom that letter writers in business put a "call" into any other shape than an out and out complaint in the shortest possible phrasing. This letter received an attention which a dozen straight complaints would not have received and more than demonstrated that business is hard only on the surface.

JOHN DOE MFG. CO.

*Gentlemen:* We turned on the 100 arcs of your company's make for the first time (for service) last evening. The 60 or more 50 c-p. incandescents had been in service when required for some nights, and were the subject of general praise and UNQUALIFIED SATISFACTION. But as for the arcs—my dreams last night were troubled. I had not seen the bulletin of that particular lamp, nor been present at the sale, but immediately upon knowing that opal inner globes had been sent, had demanded that they be replaced by clear ones, as specifications did not call for "dimers" of 75 per cent. efficiency or thereabouts.

Your Mr. X had stood strongly for the opal globes, but said that they

would be replaced by clear ones if not satisfactory on trial. We tried them, and, as I said, my dreams that night were troubled.

I saw the lamps turned on, and as the nebulous spots of light appeared in places about the town there were no "Ahs" nor "Ohs" from a pleasantly surprised multitude, but many passers who HAPPENED to see one of these lamps in a direction in which the moon never could be seen, rubbed his eyes and had sudden doubts of his own sanity as he saw what looked like a feeble resemblance of that luminary peeping at him as through a thick haze.

When they had collected their wits somewhat and began to discuss the matter with others, the idea became fairly general that what had been seen was PROBABLY the new arc lamps which were being tested by a very feeble current, and that when "full power" came on everything would be like unto the midday sun. As full current was already on and they looked in vain for any betterment, jeers, sneers and derisive laughter came from the crowd, and it was not until the abundant and mellow light of the 50 c-p. incandescents fell upon his pathway and upon his face that the impression was partially dispelled from the mind of the taxpayer that he had been sold and swindled, not knowing, poor soul, that the fault lay not in the innocent arc, but that he, the public, and even the manufacturers (when controlling spirits are SUPPOSED to hold things in balance with their COMMON-SENSE) were all the victims of the superabundant and "wise in his own conceit—expert kid," who had boxed up a large part of the light actually produced, in order that such as managed to escape might have better diffusion and a mellowness somewhat approaching the mellowness of the brains of the "expert." As the taxpayer went home we heard the incandescent singing:

"We're just old-fashioned lamps.

But we will light your feet.

That costly spark of many 'amps

Which hangs upon the street.

Calls itself an ark lamp

Of a thousand "units" power;

But when summer nights are damp

You may see from out your bower

Some tiny flashing lights

By little bugs displayed,

Which for volume and for brightness

Would put those arc lamps in the shade."

I awoke sighing deeply, and could but say—Ah, beautiful incandescent! Absolutely truthful, as well as beautiful. Would that all lamps might emulate your worth.

The arcs ran one night. They are shut down to STAY down until CLEAR inner globes arrive. One black eye is enough for either your company or myself. NO FACTORY EXPERTS WANTED OR "scientific reports," SIMPLY CLEAR GLOBES.

Yours truly,

**Portable Standard Integrating  
Wattmeter.**

JAN. 15, 1908.

EDITOR OF THE ELECTRICAL AGE,  
New York City.

Dear Sir: In the article entitled "Portable Standard Integrating Wattmeter for Testing Alternating Current Service Integrating Meters," which appeared in your issue of December, 1907, the following statement is made in the first column directly under the tabulation on page 476.

"The per cent. of error in the meter under test may be found directly by dividing the number of revolutions of the standard by the number of disk revolutions made by the service meter."

In my opinion, this statement is erroneous, for the reason that the reading of the standard should be taken as 100 per cent. and the reading of the service meter should be expressed in terms of the standard. For instance, in example 1, if the number of revolutions made by the standard is 1.03 and the revolutions of the service meter is one, then the percentage of accuracy is  $1/1.03 = 0.971$  nearly, or the service meter is 2.09 per cent. slow, instead of three per cent. slow. Again, if the number of revolutions of the standard is 0.97 and the revolutions of the service meter is one, then the percentage of accuracy is  $1/0.97 = 1.031$  nearly, or the service meter is 3.1 per cent. fast instead of three per cent. fast.

Similarly, I think that all the other calculations in the article and tabulation are wrong, due to the fundamental error in expressing the percentage accuracy of the meter under test.

Believing that the writers of the article would desire to make a correction, I have taken the liberty of calling the error to your attention.

Very truly yours,

W. F. HOWE.

Schenectady, N. Y.

**LEGAL NOTES**

**TYING OF LIGHT WIRE WITH IRON  
WIRE.**

Defendant was negligent in directing an employee to tie an electric light wire to an improper insulator with a

piece of common iron wire, where the whole danger might have been averted by having the current cut off from the light wire. *Cumberland Telephone & Telegraph Co. v. Graves, Adm'x.* Court of Appeals of Kentucky. 104 Southwestern, 356.

**NEGLIGENCE IN GETTING NEAR WIRE.**

One of the wires of an electric power company extending along a highway being down, so as to more or less obstruct the road, deceased, one of a pleasure party driving along the road, got a rope, threw it over and fastened it to a broken insulator on the wire, and while reaching for a pole on which to tie the rope, got so near the wire as to receive a fatal shock. *Held*, he was guilty of contributory negligence as matter of law. *Shade v. Bay Counties Power Co.* Supreme Court of California. 92 Pacific 62.

**NEGLIGENCE IN BOY OF TWELVE TAKING WIRE.**

An ordinarily bright and intelligent boy, twelve years old, living in a city in which electric light and power wires are in constant use on nearly all of the principal streets and highways, who, having knowledge of the danger, but not of its extent, purposely takes hold of such a wire in order to obtain a shock, and is injured thereby, is as a matter of law guilty of contributory negligence. *Johnston v. New Omaha Thomson-Houston Electric Light Co.* Supreme Court of Nebraska. 113 Northwestern, 526.

**LIGHT COMPANY NOT LIABLE.**

An electric light company is not liable for injuries through electric shock caused by plaintiff driving into wires, which trespassing boys had thrown over a light wire, and which had just come into contact with the current where the insulation was off the light wire for about an inch. *Luehrmann v. Laclede Gaslight Co.* St. Louis Court of Appeals, Missouri. 104 Southwestern, 1128.

**CONDITION OF INSULATION  
IMMATERIAL.**

Where insulation on certain electric wires, with which plaintiff came in contact and was burned, was not intended as a safety device, but was only for the protection of the wires, it was error to permit the jury to find that such insulation was old, weather-worn, broken, and out of repair, so as to afford no protection against the electric current to a person coming in contact therewith. *Rasmussen v. Wisconsin Traction, Light, Heat & Power Co.* Supreme Court of Wisconsin. 113 Northwestern, 453.

**UNINSULATED WIRES.**

Notice of the unsafe condition of an uninsulated electric light wire may be imputed to the light company from the fact that it has been in that condition for a considerable length of time, since thorough insulation is indispensable to confine the current to the wire, and the company's duty to keep its wires insulated is a continuing one, requiring careful and continuous inspection. *Luehrmann v. Laclede Gaslight Co.* St. Louis Court of Appeals, Missouri. 104 Southwestern, 1128.

**CUSTOM OF LINEMEN TO STEP ON DEAD  
WIRES.**

Evidence that it was the custom of linemen to step on and make use of dead wires in climbing poles was admissible, notwithstanding a warning bulletin from the telephone company respecting poles having electric light wires attached to them, which related only to ordinary risks. *Leque v. Madison Gas & Electric Co.* Supreme Court of Wisconsin. 113 Northwestern, 946.

**LIABILITY OF LIGHT COMPANY MAINTAINING LAMP IN STORE.**

An electric light company, furnishing and maintaining a lamp in a store and receiving monthly compensation for the service, must use reasonable care in placing it, and to that extent the company is a tenant in possession of the store as to all persons lawfully entering it. *Fish v. Waverly Electric Light & Power Co.* Court of Appeals of New York. 82 Northeastern, 150.

**SALE OF ELECTRICITY FOR PRIVATE  
LIGHTING.**

A city owning and operating an electric light plant, as authorized by Rev. St. 1895, art. 421, empowering cities to provide for lighting the streets, etc., may, after discharging its duty to the public, sell its surplus electricity to private citizens for lighting. *Crouch v. City of McKinney.* Court of Civil Appeals of Texas. 104 Southwestern, 518.

**CATALOGUE REVIEWS**

"The Treatment of Belts and Ropes for Service and Profit" is the title of an attractive 88-page pamphlet which ought to be in the hands of every superintendent or engineer because of the information it gives on belts and belt management. It contains more information about the every-day practical uses of belts than anything with which we are acquainted, quite aside from its treatment of Cling-Surface. Address Cling-Surface Co., Buffalo, N. Y.

Electrocraft Approved Electric Fittings and Revised National Electrical Code, 1907. Price, 50 cents. Electrocraft Publishing Co., Detroit, Mich.

The Standard Steel Works, Philadelphia, Pa., has sent out a handsome catalogue covering spiral and elliptical springs.

The Lazier Gas and Engine Co., Buffalo, N. Y., has sent out a unique and expensive catalogue of its product. It contains a blue print of each machine and a description of each type with much useful information.

General Electric Bulletin No. 4555 describes the application of electricity to cement plants and gives a large amount of information regarding the different processes and the apparatus used.

Fort Wayne Electric Bulletin No. 1102 gives a very lengthy list of plants operating direct-current, direct-connected generators of its manufacture. The company is also sending out its bulletin index for January. Bulletin No. 1103 describes the series arc lighting system.

The Allis-Chalmers Co. is sending out a very handsome publication, entitled "Keewatin Flour Mills," illustrating some of the important mills built by the Allis-Chalmers Co.

"Paiste Specialties" is the title of a 200-page catalogue now being mailed by H. T. Paiste Co., Philadelphia, Pa.

"Lifting Magnets," issued by the Electric Controller and Supply Co., Cleveland, Ohio, is a very handsome and complete engineering catalogue profusely illustrated in the engraver's best art. It is a complete text-book on the subject.

Murray Corliss engines are illustrated very completely in a catalogue now being sent out by the Murray Iron Works Co., Burlington, Ia.

Westinghouse Bulletin No. 1137 covers intergrading wattmeter for single-phase and polyphase alternating-current circuits and for direct-current circuits.

Allis-Chalmers Bulletin No. 2027 covers a description of the hydroelectric plant at Trinity River, Cal.

#### TRADE NOTES

The India Rubber and Gutta-Percha Insulating Co., New York, of which Dr. W. M. Habirshaw is president, and J. B. Olsen, sales manager, announces the change of its corporate

name to Habirshaw Wire Co., as of January 1, 1908.

The company was organized more than twenty years ago by Dr. Habirshaw, who contemplated the building of deep sea cables, in which gutta percha was used extensively. His selection of the names India Rubber and Gutta-Percha recalls the fierce controversy of a past generation of engineers over the respective merits of insulating materials. The total elimination of anything suggestive of the insulating compound in the present trade name is therefore significant.

The Bureau of Supplies and Accounts, Navy Department, will entertain bids January 31st for the furnishing of miscellaneous electrical supplies at New York and one 5-ton electric truck at Washington, D. C.; also for rolled bronze, soft-sheet brass and copper at Boston, Mass.

#### NEWS NOTES

The Rail Joint Co., New York, eclipsed its best production record in the year 1907. As the exclusive maker of base-supporter rail joints, and the largest producer of rail joints in the United States, it has received contracts from every quarter of the globe. At the present time it is engaged on the Panama Railroad contract. From present indications, the outlook for business for the coming year is good, and the company is hopeful of continuing its large output during 1908.

The American Thread Co., Watuppa, Mass., recently purchased a duplicate 1500 kw. Allis-Chalmers steam turbine ordered some months ago.

Mr. Geo. R. Hall has formed an engineering partnership with John Crawford, at Boulder, Colo. Their first contract is the building of a 13,200 volt three-phase transmission line about nine miles long, from Boulder to Salina, Colo., with the equipment of a substation for the distribution of 300 h.p. to the mill and mine of the Pollock Mining and Milling Co.

The Brush Electric Light and Power Co., of Galveston, Tex., has recently installed two Allis-Chalmers steam turbines of 1500 kw., normal rating. The steam plant, which consists of Heine boilers, has been increased by adding Erie and Stirling water-tube boilers.

Voltax, a well-known anti-corrosive compound manufactured by the Electric Cable Company, New York, has been specified for painting the Brooklyn suspension bridge.

*Common Sense* is the title of an attractive pamphlet issued monthly by

the Electric Controller & Supply Co., Cleveland, O. It is interesting and well illustrated, and if the succeeding issues hold to the standard of the initial number, *Common Sense* will have a wide circulation.

The United Verde Copper Co. has installed a second three-motor Northern traveling crane, in addition to the 50-ton crane supplied several months ago.

The Lord Electric Co., New York, has concluded arrangements with Chas. I. Earl for the manufacture and sale of his trolley retriever and catcher. It is a most ingenious contrivance, very strong and durable, easy of access, free from complications, attractive in structure and built on good engineering principles. Many of the largest of the most representative properties in the United States have adopted this device.

W. R. Garton, formerly president of the W. R. Garton Co., Chicago, is now general manager of the Lord Electric Co., New York.

The Standard Steel Works Co., Philadelphia, Pa., is sending out its catalogue on springs to those interested.

January issue of *Light*, published by the United Electric Light & Power Co., New York, notes the lighting of the entire Manhattan approach of the 207th Street bridge over the Harlem River by the company's mains and the replacement of the steam-driven draw-bridge by two 20-h.p. alternating-current motors.

In the new Fulton Terminal Buildings, New York, which will be ready for occupancy in May, 1908, the Machinery Club of the City of New York will occupy the 20th and 21st floors, including a roof-garden. The membership of the Machinery Club is limited by the present constitution and by-laws to a possible membership of 750 resident, 500 suburban and 1000 non-resident members. The membership list is already representative of the machinery interests of the United States. It is expected that a waiting list will have to be shortly established.

On the 29th of January, 1908, Arthur Killyan, Esq., City of Niagara Falls, N. Y., will act as Referee in the petition of the Niagara Tachometer and Instrument Co. to be declared bankrupt. The petition is signed by Henry A. Francis, de Lancey Rankine, Chas. R. Huntley, Geo. J. Howard, Wm. A. Brackenridge, Benjamin V. Norton. Henry A. Francis has been appointed temporary receiver for the company.



# THE ELECTRICAL AGE

Volume XXXIX. Number 2.  
\$1.00 a year; 15 cents a copy

New York, February, 1908

The Electrical Age Co.  
New York and London

ESTABLISHED 1883

Published monthly by The Electrical Age Co., 45 E. 42d Street, New York.

J. H. SMITH, Pres. C. A. HOPE, Sec. and Treas.

JOHN HAYS SMITH, Editor.

Telephone No. 6498 38th. Private branch exchange connecting all departments.

Cable Address—Revolvable, New York.

## SUBSCRIPTION RATES

United States and Mexico, \$1.00; Canada, \$1.50. To Other Countries, \$2.50

## NOTICE TO ADVERTISERS

Insertion of new advertisements or changes of copy cannot be guaranteed for the following issue if received later than the 15th of each month.

## LONDON OFFICES

Business and Editorial Departments, 33 Bedford Street  
Strand, W. C.

London Telephone, Post Office, 3807 Central. Private branch exchange. London Cable  
Address—Revolvable, London.

All remittances to London Office should be crossed London and County Banking Company.

## BRANCH OFFICES AND AGENCIES

Subscriptions may be sent to the following branch offices or agencies, where they will receive the same careful attention as at the home office in New York:

124, Queen St., Melbourne  
359, George St., Sydney  
61, Main St., Yokohama  
23, Esplanada Rd., Bombay

33, Loop St., Cape Town  
Unter den Linden, 5, Berlin  
Nevsky Prospect, St. Petersburg  
31, bis rue de Faubourg Montmartre, Paris

General Agents for United States and Canada: The American News Company

## Water Powers of the Southern Appalachian Streams.

The streams whose headwaters lie among the peaks of the Southern Appalachians, flowing westward to the Mississippi or eastward to the Atlantic, furnish opportunities for the development of water power so wonderful that the meagerness of their present use for this purpose is little less than marvelous. The position of these rivers as prime factors in the industrial growth of the South is well recognized, and the power development that has taken place in the region thus watered is unparalleled in any other portion of the United States.

Engineers of the United States Geological Survey, after making a careful study of the streams, the quantity of water they carry, and their fall in various portions of their courses, have estimated that they afford a minimum of about 2,800,000 horse power, at least 50 per cent. of which, or 1,400,000 h.p., is available for economic development. These figures, it should be noted, represent the minimum horse power. If auxiliary power were provided to supplement the water in short seasons of deficiency,  $2\frac{1}{2}$  times this amount might be profitably utilized; and if the flood waters could be stored and the flow of the streams properly regulated, the minimum power available for economic development might be increased from three to 15 times. It is evident, therefore, that an estimate of the present value of these water powers, based on 50 per cent. of the minimum indicated horse power, has so many factors of safety that it is very conservative.

An extremely low average of the present rental value of water power is \$20 per horse power per year. The rental value of 1,400,000 h.p. would therefore amount to \$28,000,000, which is equivalent to an income

of 3 per cent. on a capital of \$933,000,000. But the resource represented by this water power is far greater than its present market value. The enormous and wasteful consumption of fuel is so rapidly depleting the supply that it must become more and more costly. As a result the present disparity between the cost of fuel power and that of water power will constantly increase, and the demand for water power will increase accordingly.

## The Decker Cell

"One is at a loss to point out any radical or even important advance in primary batteries since the time of these fundamental improvements," declared F. B. Crocker, past president of the A. I. E. E. and present professor of electrical engineering at Columbia University, in outlining the early development of the primary battery in a lecture before the American Electrochemical Society, Oct. 8, 1906, on the Decker primary battery. In making this unqualified statement there would seem to be a deliberate evasion of the fact that practically none of the types earlier alluded to in the address are in use, and that the only battery now in use in any number for supplying power continuously is the Edison-Lalande type. So epochal was the development of the Edison cell among primary batteries that it practically seized the commercial market.

It is claimed for the Decker battery that the cost of producing power is at the rate of 35 cents per h.p.h., or 47 cents per kilowatt-hour, this calculation being a theoretical one based on the consumption of zinc and chemicals alone, the estimated figure reducing to 15 cents per h.p.h., or 20 cents per kilowatt-hour where the cells are used in so great numbers as to justify reclaiming the zinc from the exhausted battery fluid by electrolytic

action. Exact data on this process have not been given forth, so that it is hardly possible to examine them. It is not exactly clear whether it is proposed to use Decker current in this process, in which case we should have the signal operation of decomposing electrolytes by the same chemical forces which unite them in producing current flow and which we are taught is impossible under the laws of electrolytes, being a chemical process very like perpetual motion in mechanics; or whether the current for reclaiming the battery solution will be central station power service at two or three cents per kilowatt-hour. If the latter, we are of the opinion that the operation would have to be on a very large scale to be successful. The cost of electrolytic current can be but a small part of the cost of such a process.

It is admitted that 47 cents per kilowatt-hour is a high figure, but nevertheless it is ambitiously proposed to enter the fields of light, power and vehicle work with the Decker battery, and to do so an enormous sum of money is to be raised. The promoters of the company of which F. B. Crocker is president, are endeavoring to raise \$3,000,000 by selling 200,000 shares of stock, par value, 100 at \$15 per share, making the total capitalization \$20,000,000. How large these figures are in the primary battery field, and how certain the promoters feel of their ground may be gauged by the fact that the entire amount of money now invested in the manufacture of primary batteries in the United States is somewhat less than \$1,000,000, or one-third the amount which is adjudged necessary to demonstrate the revolutionary changes which the new cell is destined to make.

The Decker Electrical Mfg. Company, which is the name of the concern organized to float the battery, has offices at Baltimore, Philadelphia, New York and main offices at Wil-

mington, Del., at all of which it has been selling stock during the last year. A factory has been built at Philadelphia and batteries are being manufactured for sale.

The battery is, in essential elements, not new. It is the old bichromate cell. The novel thing about it is the mechanical arrangement for filling and emptying the cell, which may be accomplished by a siphon action or by air pressure. This arrangement is a welcome improvement on the old plunge type of bichromate cell of which this may be described as a new and mechanically improved type.

In Prof. Crocker's address, he states that the new type gives 14.7 watt-hr. per lb. of battery. This figure was obtained only after shaking the battery to get a further output by facilitating the action of the depolarizing bichromate solution, which figure is further stated significantly to be about "twice as great as that obtained in standard types." In this statement the writer is evidently in error, as there are cells on the market giving nine to 14 watts per lb., and a new storage cell has this figure just about doubled in its claims.

There is evidently, also, a difference of opinion as to the watt-hour per lb. output of the battery, as Prof. Carl Hering, after a test of a 16-cell battery, stated in a lecture before the American Electrochemical Society, Oct. 18, 1906, "that the capacity was nearly at the rate of 10 watts per lb. of complete cell."

It is seriously proposed to employ the Decker battery in train lighting, and it is stated that the cost per car is \$4 per night with tungsten lamps as against \$6 per night with carbon lamps and storage batteries. Since the latter figure on storage batteries will, on the basis of tungsten efficiency, be only one-third as much as carbon filament lamps, the true comparison figure is \$2 per night for storage batteries, or half as much as the cost of the Decker outfit. It would seem, if these figures are correct, that in the present form of the proposition this is not a promising field for the exploitation of the cell.

It would hardly appear that a better case could be made out in electric vehicle work for the new cell. To mention one item alone the discharge time for the cell is too short. It is given as  $5\frac{1}{4}$  hr., which is too short an interval for a trucking day of 8 to 12 hr.

It would be necessary with the Decker outfit to employ two storage tanks, one for chemicals to renew the battery fluid and one to provide storage for the spent liquids, together with an automatic pump to accomplish the transfer of liquids to and from

the battery. A reasonable amount of piping and drip cocks would be necessary to arrange all of this. So in place of the simple charging process of the storage battery we should have a double reservoir storage to accomplish at the garage, and a renewal of all the zinc elements every day or other day—present zincs last for three charges only.

The replacement of the zinc in itself would be a serious task in a battery, which would have to contain at least 70 zincs to get potential. Vehicle motors are 110-volt and an average E. M. F. of the Decker cell as stated by Dr. Hering is 1.64 volts.

If in addition to the labor items mentioned above it were necessary to operate a reclaiming plant, it can easily be seen that the outfit cannot be so easily or cheaply handled as storage battery charging.

If now we take up the question of cost operation we are still further surprised that the Decker cell could be seriously considered for vehicle work.

In the Edison type of storage battery it costs about \$1 per day for current at six cents per kilowatt-hour, practically nothing for fluid renewal, and only from 15 to 20 cents a day for maintenance. The total is about \$1.25 per day. The corresponding figure for the Exide cell is probably \$2 per day at a minimum. Both of these values are attained in electrical vehicle operation.

Let us now compute the cost of Decker current. Assuming the figures which have been given by Prof. Crocker, the president of the company, and they may be taken as authoritative and at the same time as the most favorable which can be shown for it.

Assuming an average output for the vehicle motor of 1.75 h.p., an average time of running of eight hours, and we have a current requirement of 14 h.p.-hr. or 10 kw-hr. If the average efficiency of the motor and its resistances is 70 per cent., the battery input will have to be 14 kw-hr. and at 47 cents per kilowatt-hour the total daily cost would be \$6.58. Assuming a figure of 20 cents per kilowatt-hour to be attained by the reclaiming process, and this figure is not established by published tests, Decker current alone would cost \$2.80 per day. Both of these current figures are greatly in excess of machine generated current, which can reach a value as low as 30 cents per day with current at two cents per kilowatt-hour.

The computations given above for the Decker outfit are probably too low for the reason that the 47-cent and the 20-cent rate are based merely on the theoretical cost of battery materials and do not include inspection,

attendance, etc., which are included in the storage battery figures given above.

We are of the opinion that while the battery is destined for no extensive use for vehicle or lighting work, it may be found useful where there is no supply of service current. This field is widening daily, but on the whole, it is rather inconsequential, owing to the rapid spread of central power service.

It is our opinion, also, that it were better for the men interested in the company to try the battery out on a reasonable business scale of operation instead of attempting to raise from the dear public a sum many times over that invested in the battery business at the present time. And while we are not surprised that a battery inventor should take this means of raising money, we are most emphatically surprised that an honored past president of the American Institute of Electrical Engineers, who is reputed to be heavily interested in and is known as one of the founders of the large Crocker-Wheeler Co., and is at the present time professor of electrical engineering at Columbia University—we are surprised that he should head a promoting venture of this sort. There is plenty of capital in the electrical industry itself in the control of men who know the commercial field for inventions without asking the unknowing public for it.

#### Mica

Mica is the most expensive raw product used in the manufacture of electrical machinery, and the economical employment of it is rather a difficult problem for the manufacturer. There is a choice of various sized pieces and a choice of various varieties of mica and the price ranges from \$5 to \$6 per pound for first-grade selected mica sheets, approximately 6 by 8 in. in size, down to uncut mica in 2-in. pieces at 13 cents per pound. North Carolina mica costs 25.7 cents, whereas New Hampshire mica costs 3.6 cents and Virginia 2.0 cents.

As a single illustration, consider the matter of commutator insulation.

For insulation between segments of commutators there is nothing superior to the Canadian amber mica and certain varieties of India mica. The latter is of about the same hardness as the hard-drawn copper segments of the commutator, and the whole wears down evenly. Considerable muscovite, or white mica, is employed for this purpose, but its inferiority does not show up for some time. Black-specked mica, in which specking is due to minute crystals of iron oxid, is purchased in large quantities by electrical dealers. It is, however, danger-

ous to use it for insulation against high potential currents. It is said that it can be used for insulation purposes where the current is under a 1000 volts. The temptation to use it can be gaged from the fact that it costs only from one-half to two-thirds as much as clear mica. Many of the large electrical manufacturers will not use this variety of mica under any circumstance.

According to the last report of the United States Geological Survey, the production of sheet mica amounted to 1,423,100 lb. in the United States, of which about two-thirds was mined in North Carolina. In the year 1906 about 3,000,000 lb. of mica was imported. Less than one-third of the entire quantity used in the United States in 1906 was of home production. The increase in the year 1906 over the year 1905 of sheet mica was about 78 per cent., the total consumption reaching about 4,500,000 lb.

#### The Professional Electrical Course

The teaching of electrical engineering is still very far behind its sister professions and is in a generally unsatisfactory condition. The frequent discussion of the topic itself, the unanimity of agreement among those who are most interested, and the constant discussion of the matter by the manufacturing engineers themselves, all too clearly point to its unsatisfactory state.

Most of the eminent critics have contented themselves by pointing out defects in the present pattern of instruction, some few have suggested that none but practical men should teach, and lest these should go to seed it has been urged that the incumbent of the professorial chair and his assistants should at year-long intervals, take a dip back into commercial engineering. But we do not recall one genuine effort to get at an understanding of the matter.

As in a problem of science it becomes necessary to establish limiting conditions and controlling influences, so in an effort to make a satisfactory curriculum it should be determined, first of all, to just what point instruction will be carried, where practice shall begin and how much of it shall be given.

Of the four years of study in the usual electrical curriculum three are spent in assimilating the rudiments of raw science and in laying the ground work for later instruction. One short year is devoted strictly to electrical engineering. It is not surprising that graduates have to spend practically

two or more years in apprentice work in order to fit them for professional work. No other professional school attempts to teach its novitiates in so short a time and electrical engineering is not less complex than any other branch of professional work.

More time must be given to electrical engineering *per se*, and the amount and character of this work must be approximately specified, so that it joins to the present-day requirements of electrical engineering.

Let the A. I. E. E. appoint a committee of three from manufacturing companies, three from operating companies, three consulting engineers and three members selected from engineering schools. Such a committee should know what is best. Let them mark out what attainments a student should have who knocks for admittance to practical work. Let them fix the plan. Then suit the educational work to the plan and trim all the subsidiary instruction to the main lines of professional teaching. We are of the opinion that such a committee, in its recommendations, would probably reverse the present apportionment of time between raw science and electrical engineering. One result is almost certain. Those institutions which could adjust themselves to a new alignment in their professional courses would do so. The time has arrived when the study of electrical engineering should be dignified by the creation of professional schools.

#### The Westinghouse Situation

One of our esteemed but fallible contemporaries, which had nothing to say in its strictly editorial column in the week following the announcement of the Westinghouse receivership, now announces that it is a matter of pleasure to note how rapidly the Westinghouse situation is righting itself.

This magazine last November announced confidently that a situation of so vital importance to the entire electrical industry would right itself.

Succeeding events are proving its estimate of the situation to be correct.

The Westinghouse Lamp Company has been discharged from its receivership, and it is now announced that 99 per cent. of the \$7,000,000 liabilities of the Westinghouse Machine Co. have assented to the proposed financing plan for that company.

The great courage and indomitable will of George Westinghouse are once more riding over a situation of which our contemporary now says, "As one looks back the vista to last October shortens up, and it is seen how super-

ficial, in a sense, the embarrassment of the moment was seriously as its pinch was felt temporarily"—whatever that may mean.

#### The Tungsten Filament

With the advent of the new tungsten filament we are likely to see a revival of the old struggle to get a sufficient downward distribution from the lamp itself. It will be recalled that the old Edison hair-pin filament gave a downward distribution of only 2 c-p. on a 16-c-p. lamp. The 2 c-p. of downward distribution just about represented the proportional part of the loop illumination. When the double hair-pin filament was introduced the downward distribution was doubled, and with the introduction of the double oval filament the light was nearly quadrupled. In order to increase the downward illumination of this type of lamp common use is made of prismatic reflectors capable of increasing the downward illumination ordinarily to about 40 c-p. The exact intensity of illumination can be varied, however, by the design of the reflecting bowl.

While the prismatic bowl is not ordinarily required in the common form of carbon lamp giving 7 c-p. downward from a 16-c-p. lamp, it is almost an absolute necessity with the tungsten lamp giving only about 8 c-p. downward from a 40-c-p. lamp.

In the new tungsten filament we have no portion of the filament radiating directly downward. Consequently, it gives the old familiar black spot of the hair-pin filament, and is rather unsuited for use in individual lights.

#### The Step Bearing

It is a question of considerable moment in view of the large number of vertical type turbines in use whether some means ought not to be employed to provide an emergency source of oil pressure for the step bearing. The pressure at this point is so enormous—600 to 850 lb. per sq. in.—that the slightest failure of the pump is liable to bring the machine down on its step and put it out of action. If this were merely a momentary affair like the blowing of a fuse or the tripping of a circuit-breaker it were unimportant. But it is more serious. The machine is put out of commission for a considerable length of time and the bearing is usually destroyed. While it is not an expensive matter to repair the damage, the unreliability of the device is seriously a matter for consideration. Sound engineering is usually reliable engineering.

# The Central Station Distributing System

## Systems of Distribution

H. B. GEAR and P. F. WILLIAMS

Commonwealth Edison Co., Chicago.

THE early development of electrical properties having been limited to the use of the direct-current dynamo and motor, direct-current systems were the pioneers in central-station distribution work.

Electricity was generated and transmitted at the voltages at which it was delivered to the consumer, and stations were located with reference to the location of the load as far as possible.

These developments were begun in the larger cities, where the demand for electricity was greatest and where the geographical situation was such that the use of electricity was confined within comparatively small areas. This led naturally to the development of interconnected networks of low-tension mains, supplied by feeders at various points. These networks were interconnected through junction boxes at intersecting points, the lines from which customers' services were taken being called mains and lines from the station to definite points in the system being known as feeders.

Having had an early start, and having been fully justified by the demand for direct current for elevators and other variable speed machinery, these direct-current systems are found in the central portions of many of the larger cities of the United States and Europe.

The extension of distributing systems into the more scattered portions of the larger cities and the necessity of reduction of the cost of installation directed attention to systems in which higher voltages could be employed. The possibility of the use of the transformer naturally led to the use of alternating current generated at a voltage of about 1100 and transformed down to 110 at the consumer's premises.

This made possible the installation of a distributing system covering the more remote parts of a city with a much less weight of copper in distributing mains and feeders. These earlier installations were operated single-phase at a frequency of 125 to 133 cycles, which permitted a less expensive design of transformer, but was not well adapted to motor service. The growth of the demand for power service resulted in the development of polyphase systems of 60 cycles and

2200 volts, which permitted further economy of copper, and put the alternating-current stations more nearly on a par with the direct-current systems in the matter of power service.

The direct-current station managers were not slow to recognize the possibilities of a combination of the poly-phase system with rotary converters for the purpose of transmitting large loads over considerable distances. This enabled them to consolidate their smaller generating stations into one large plant, utilizing the smaller generating stations as converter substations. The introduction of the rotary converter made desirable a still lower frequency than 60 cycles, and 25 cycle generators were accordingly provided for the large stations. Voltages were selected with less uniformity, however, the range being from 6600 to 13,200, depending upon local conditions.

As a result of this evolution, the following general types of distributing systems have come into more or less extensive use:

1. *Direct current, two-wire and three-wire.*

This is the simplest system of distribution, since the electric current passes directly from the generator to the consumer without any intervening transforming or regulating apparatus. The voltage at the consumer's premises is that at which the electricity is generated less the loss of transmission.

The voltage is therefore limited to that at which the consumer may conveniently utilize the current, which, for lighting purposes, may not exceed 220 to 250 and for power purposes, 500 to 600. The earliest incandescent lamps were limited to about 110 volts, and two-wire 110-volt plants were the pioneers. The cost of feeders soon led Edison to devise his three-wire system in which two generators were connected in series, a third or neutral wire being carried from the midpoint between the generators. This permitted the use of 110-volt lamps connected between the neutral and either outer conductor, while motors could be connected across the outside and operated at 220 volts. This was equivalent to doubling the voltage of the system, as the load could be kept approximately balanced between the

two sides of the three-wire system. The current for a given load was thus halved and the radius of transmission was doubled. At 220 volts the loss on any feeder is about 10 per cent. when it is carrying one ampere per 1000 cir. mils a distance of 1000 ft. When a feeder on a 220-volt system is much over a 1000 ft. long it is therefore necessary to use more copper than is required for safe current carrying capacity, or to install a booster to make up the excessive loss on the longer feeder.

The location of a 110-220 volt two-wire or three-wire station or substation should therefore be such that the average length of the low-tension feeders does not exceed 1000 ft. and the longest feeder should not exceed 2500 to 3000 ft. In a 500-volt two-wire power system or in a 220-440-volt three-wire system the radius should be 2000 ft. for the average feeder, and not to exceed 5000 or 6000 ft. for the longest.

The 110-volt system has so narrow a range that it is not advisable to use it for distribution purposes, except in small isolated plants.

The three-wire 110-220-volt system is suitable where the load is mostly within a radius of 1200 to 1500 ft. from the station and where there is a demand for direct current for power purposes.

The 220-440-volt system may be used where the load is within a radius of half a mile from the station. This system is subject, however, to the serious handicap of low efficiency incandescent lamps and the necessity of using 220-volt arc lamps, fan motors and similar small apparatus, which is more practical at 110 volts.

The 500-volt system for power purposes is suitable where the load is within a radius of about 5000 ft. and is found useful as a means of furnishing power for elevators and other variable speed machinery in cities where the existing alternating-lighting system is not well adapted to power work. This arrangement, however, requires a separate distributing system paralleling the lighting system which occupies pole and duct space and increases the cost of maintenance.

The foregoing limitations of direct-current systems therefore restrict the use of such systems to localities where

power is required for variable speed machinery and where the lighting load is densely distributed near the point of supply. This is the condition in parts of large cities, in large industrial manufacturing plants and in some large amusement parks.

2. *Single-phase Alternating Current.*

In this system alternating current is usually generated at about 2200 volts and 60 cycles. It is delivered to feeders at the same voltage, and from the feeders distributed over primary mains to transformers located near the consumer who is to be served. These transformers reduce the pressure to the usual working voltages of 110-220,

ing in copper incident to the use of the higher voltage.

The single-phase system is not well adapted to locations where there is a considerable power load, owing to the limitations of the single-phase motor. It is best suited to cities where the power load is in units of not more than 20 to 25 h.p., and where no considerable saving would be realized from three-phase transmission.

3. *Two-phase system.*

In this system electricity is delivered at about 2200 volts by four-wire two-phase, three-wire two-phase or two-wire single-phase feeders and primary mains to transformers. These reduce the pressure to the usual voltages of

cost of two small transformers as compared with one large one.

When the generators or transformers supplying a two-phase system may be L connected, as shown in Fig. 2, one wire of each phase may be made a common or neutral wire and the feeder and main system reduced to a three-wire basis.

The neutral wire in such a system carries the resultant of the current in the two phases, which is 41.4 per cent. more than that in the phase wires. That is, in a feeder carrying 100 amperes on each phase wire the neutral wire carries 141.4 amperes.

If the same size of wire is used on each leg of the circuit, the energy loss is the same as it would be in a four-wire feeder under similar conditions. There being but three wires, it is obvi-

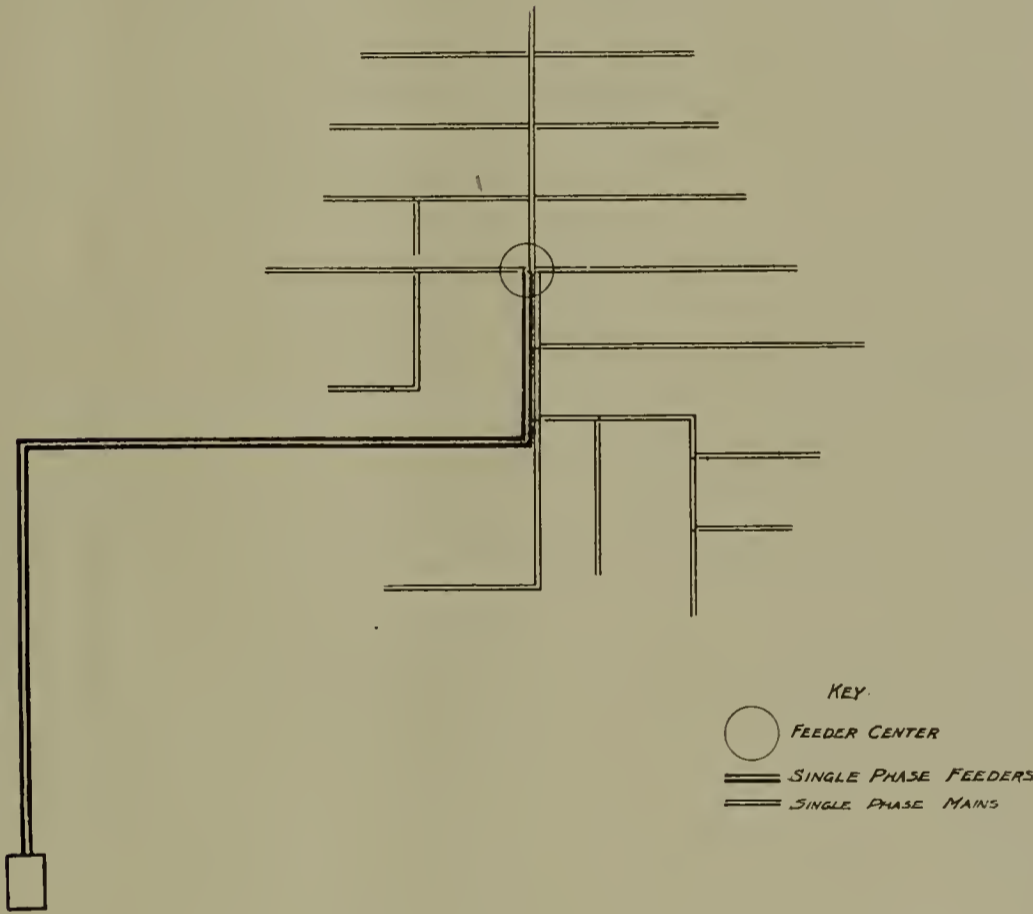

FIG. 1.

at which pressure the electricity is distributed over secondary mains to the consumer's premises.

The general arrangement of a feeder and its primary mains on this system is shown in Fig. 1.

This system being operated at 2200 volts permits of distribution within a radius of two miles from the point of supply without the use of more copper than is required for current carrying capacity. More distant points may be reached by the use of booster transformers or potential regulators.

The distributing mains also have a radius from the feeder end about ten times greater than that of a 220-volt system, which makes it possible to distribute a widely scattered load from a smaller number of feeders, carrying heavier loads than would be feasible with low-tension feeders.

The use of transformers and secondary mains partially offsets the sav-

ing in copper incident to the use of the higher voltage.

Single-phase feeders are run in territory where no larger power service

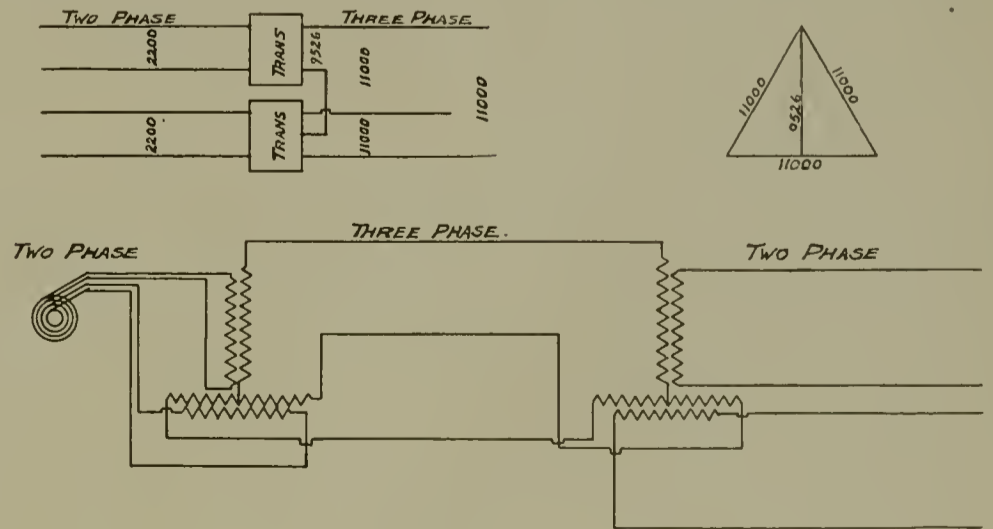
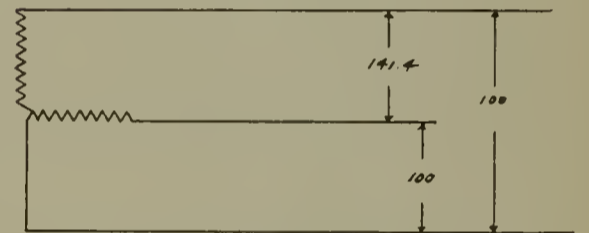
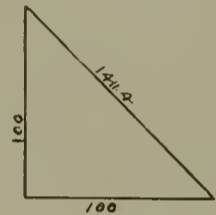

FIG. 3.

is required. Consumers requiring less than 5 h.p. are usually not given two-phase service, owing to the extra

a larger conductor on the neutral, in which case the saving may not be more than 10 or 15 per cent.



THREE WIRE TWO PHASE SYSTEM

FIG. 2.

ous that there is but 75 per cent. as much copper required for this system as for a four-wire system under equivalent conditions.

In cases where feeders are short and the carrying capacity of wires must be considered as well as regulation, it is sometimes necessary to use

In the primary distributing mains, where for mechanical reasons no wire smaller than No. 6 should be used, a saving of 25 per cent. is generally realized.

Where the system is used with a transmission beyond the limits of the generated voltage, it is usual to step up the voltage by two transformers connected as in Fig. 3. This is sometimes known as the "Scott connection," and produces three-phase current on the secondary side, permitting the transmission to be made on the three-phase system. The reverse arrangement is usually used at the remote end to secure the simplicity of the two-phase system in distribution, but the distribution may be made on the three-phase system if the load is maintained in approximate balance on the three phases at all times.

and where the lighting load is not heavy.

The three-phase feeders may carry lighting on one phase only, as in the case where the load is mostly lighting and does not exceed 200 kw., or they may carry lighting on all phases, as is usual where load of 200 to 500 kw. come within an area which can be properly served by a single feeder. The primary mains are three wire where power or heavy lighting loads are to be served and two wire where a small lighting load only is carried.

Where three-wire feeders approximately balanced, can be used on this system there is a saving of 25 per cent. in feeder copper over the single-phase system. Pressure regulation, however, is difficult if the load is unbalanced, since the adjustment of either potential regulator affects the

5. Three-phase four-wire system.

Alternating current of 60 cycles is supplied at 2200 volts between either phase and neutral point of a Y-connected generator or transformers and 3800 volts between phase wires. Two-wire single-phase feeders and mains supply sections where no large power is required, being connected from phase to neutral at 2200 volts.

Where the load in a given section consists of both lighting and power a four-wire three-phase feeder is run to a center of distribution so located that a proper arrangement of lighting mains may be made. If the lighting is not sufficient to load the three phases it may all be put on one or two phases, thus saving the expense of regulators and instruments until they are required on the other phases.

In cases where the lighting is sufficient to load three phases, but power load is very small, it is preferable to

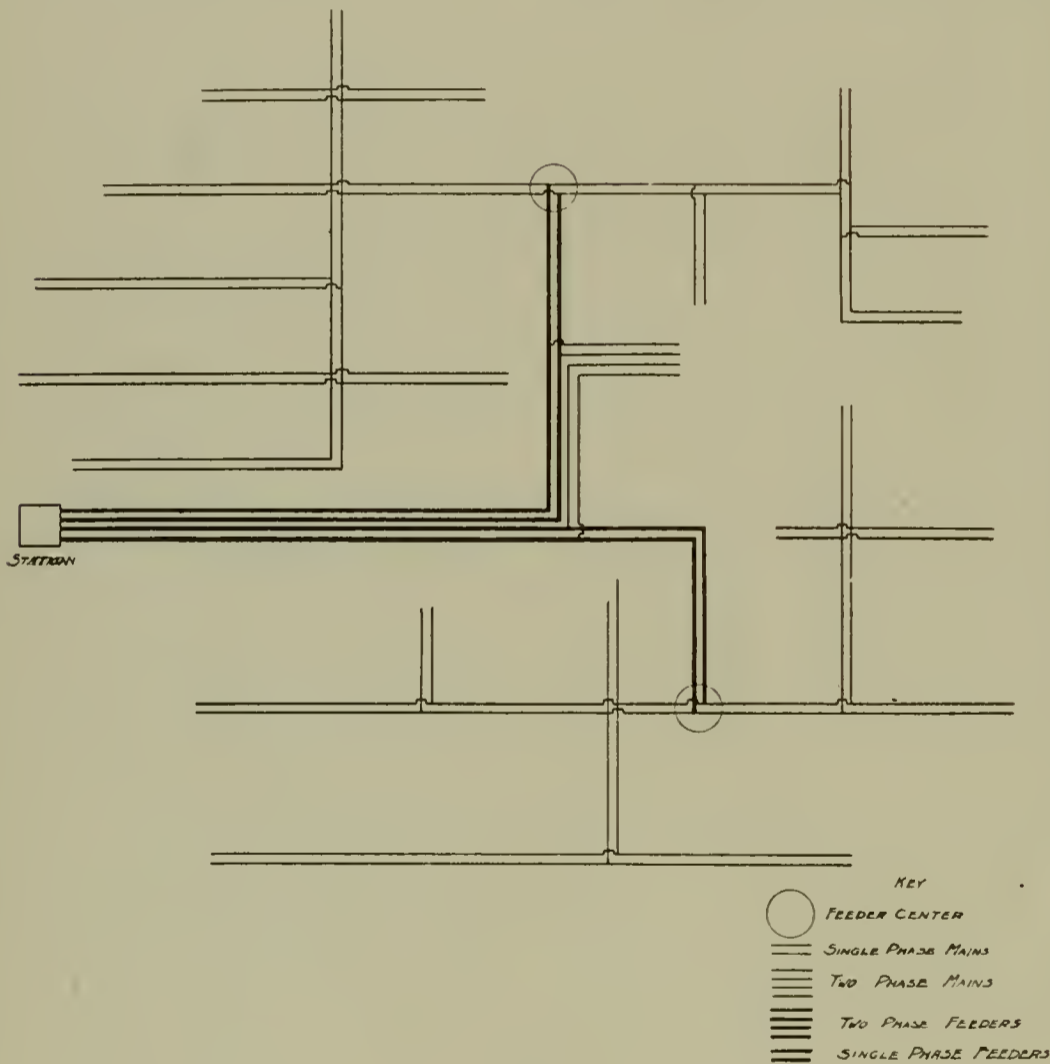

FIG. 4.

The four-wire two-phase system is illustrated in Fig. 4.

4. Three-phase three-wire system.

Electricity is usually distributed in this system at 2200 volts and 60 cycles by means of two-wire single-phase or three-wire three-phase feeders and primary mains at the same voltage. This is stepped down by transformers to supply 110-volt two-wire, 110-220 volts three-wire single-phase, or 115-200 volt four-wire three-phase secondary mains.

The two-wire feeders supply territory in which power is not required

pressure on two phases and regulation is therefore somewhat cumbersome.

Power services demanding 5 to 20 h.p. may be supplied from two phases by the open delta connection as shown in Fig. 5, thus effecting a saving in transformer investment.

The development of new power territory or additional lighting feeder capacity is readily accomplished by the addition of a third wire to a single-phase feeder, thus converting it into a three-phase feeder.

The arrangement of feeders and mains in this system is shown in Fig. 6.

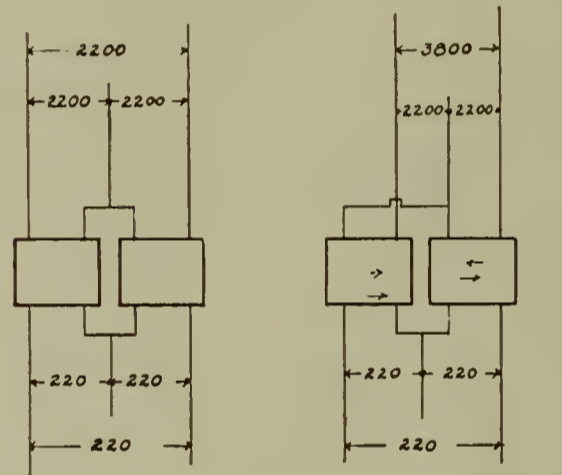

THREE WIRE THREE PHASE FOUR WIRE THREE PHASE.

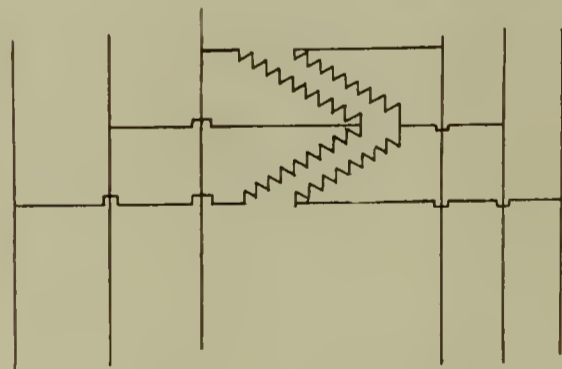

OPEN DELTA CONNECTION.

FIG. 5.

establish separate single-phase centers of distribution with single-phase mains. The lighting in a given section may thus all be carried from one phase and two-wire mains will suffice instead of the three- or four-wire mains, which are necessary where both light and power are to be carried. The extra power phases are carried only where they are needed for the few power consumers. In such situations the four-wire feeder permits three-phase transmission to be made from the station to the point where the single-phase feeders diverge, thus securing practically the same economy in cop-

per as in the case of a purely three-phase arrangement.

The preservation of a balance on the feeder is not necessary, as the neu-

lines where there are two or more phases present, since the difference of potential between phases is about 3800 volts instead of 2200. This system re-

quired for a three-wire three-phase system at 2200 volts under equivalent conditions.

Standard 2200-volt transformers may be used for all purposes, being Y connected for power purposes and fed from a phase wire and neutral for lighting purposes.

6. *Combination systems.*

Such systems consist in the use of two or more of the above-described systems in combination. In direct-current systems the combination is usually made with a three-phase alternating system in order to facilitate transmission of electricity in large quantities. In alternating systems combination is sometimes necessary between two systems operating at different frequencies, or with a direct-current system.

Combination systems are usually the result of the development of the local distribution to a point where it becomes more economical to feed the mains from two or more sources of supply. Sufficient is saved in the reduction of the length and size of the distributing feeders to provide capital with which to erect substations and install transmission lines. The conversion losses are not excessive, and the ability to concentrate all the generating plants into one results in much better economy of production.

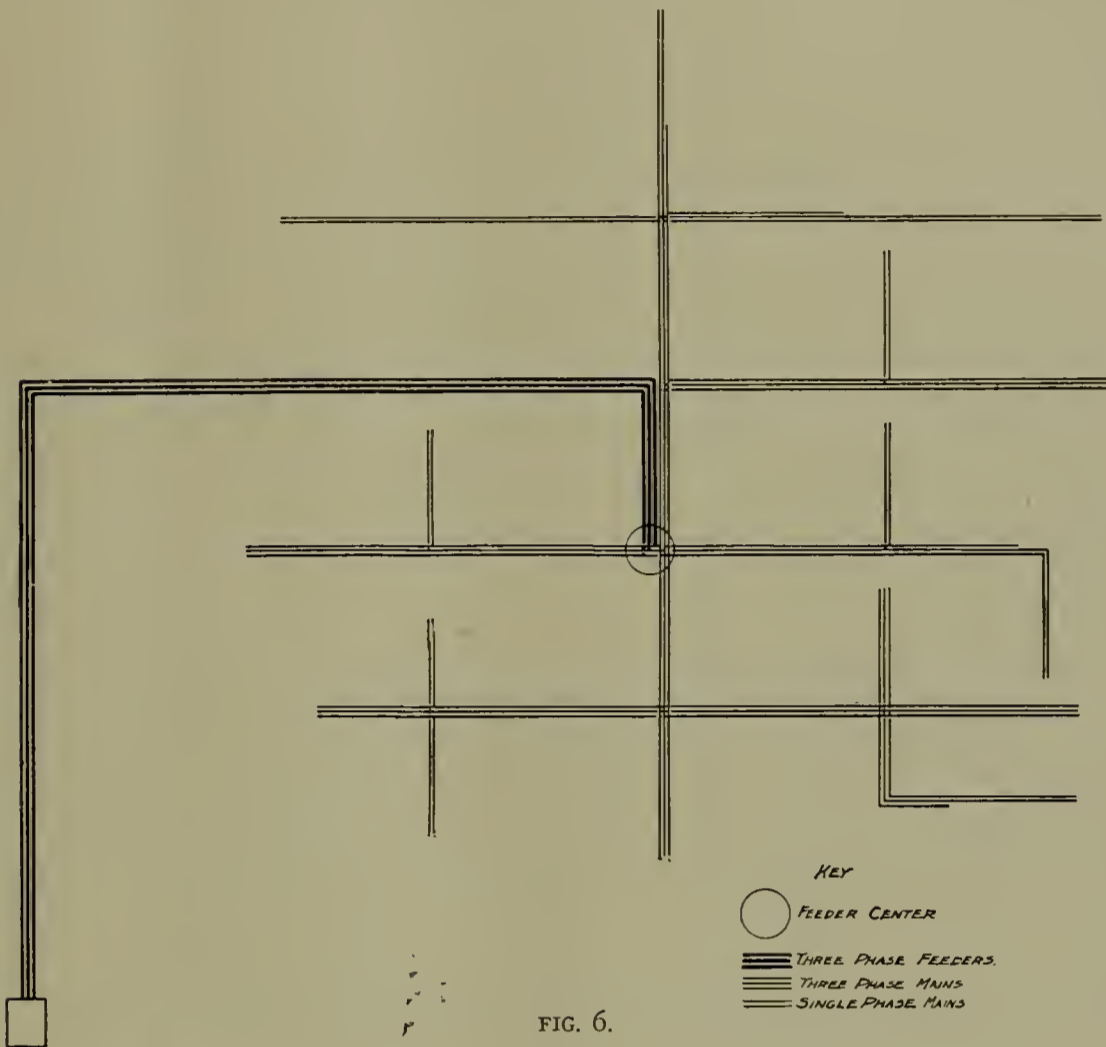

FIG. 6.

tral wire carries the out-of-balance current, and the drop may easily be compensated for by the use of line-drop compensators in one of the four wires of the feeder.

Installations of 5 to 20 h.p. may be supplied from two phases and the neutral by the open-delta transformer connection without interfering with regulation, as in the three-wire three-phase system.

The arrangement of feeder and mains in this system is shown in Fig. 7.

The especial advantage of this system is that when there is sufficient load to require a three-phase feeder the transmission is effected at 3800 volts, and loads up to 500 kw. may be distributed from a single feeder at distances of over three miles from the station with four wires, whose size is fixed only by their current carrying capacity.

The neutral wire in this system naturally runs near earth potential and is therefore usually grounded at the generating station. This makes it necessary to look after the insulation of lighting-arrester cases, cables at points where they join overhead wires, fuse boxes and other fittings somewhat more carefully than in other systems. It is also necessary that linemen exercise more care in working on

quires one-third the copper required for a single- or two-phase system at 2200 volts, or 44.4 per cent. of that

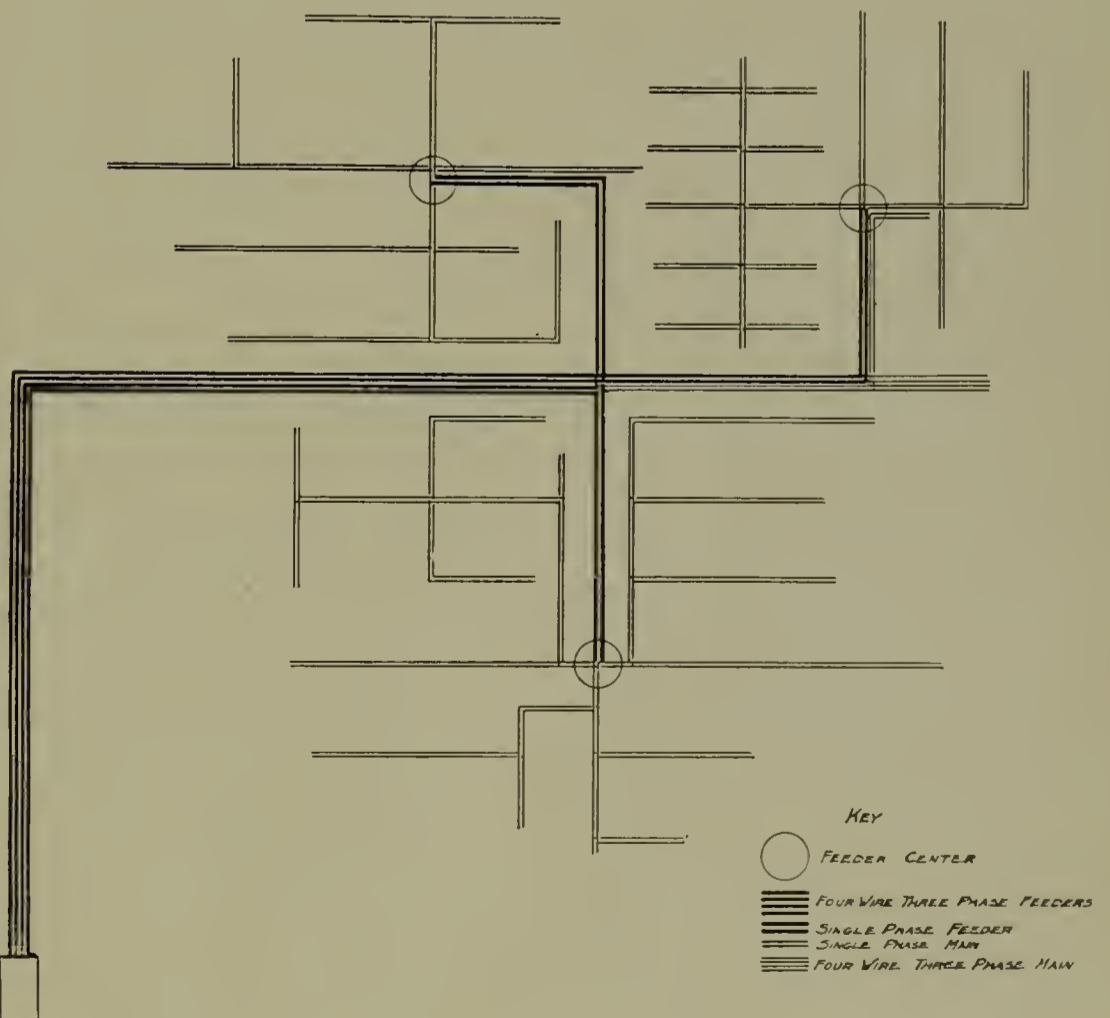

FIG. 7.

Both motor generators and synchronous converters, commonly called rotary converters, are used in the con-

version of the alternating current to direct current.

Where systems operating at two frequencies must be combined a motor generator is required, the motor being either of the synchronous or induction type. The synchronous motor may be wound for the transmission voltage and therefore requires no step-down transformer unless the transmission voltage exceeds 13,000.

The commonest form of combination system is that which generates alternating current for transmission and converts it to direct current at substations, by means of synchronous converters, for purposes of distribution.

The superior economy of the synchronous converter outweighs its disadvantages in most localities, and the large direct-current systems in cities like New York and Chicago utilize synchronous converters in preference to motor generators.

The transmission systems in such cities are therefore operated at 25 cycles in order to insure freedom from trouble with hunting or flashing of rotary converters.

The portion of the load which is distributed as alternating current must then be generated by separate 60-cycle steam-driven generators, or by 25-cycle motor-driven generators, since 25-cycle current is not well adapted to lighting, and is therefore not as salable as 60-cycle electricity.

Where the 60-cycle distribution predominates electricity is preferably generated at this frequency, and the portion required in the form of direct current is secured through motor generators.

The selection of the transmission frequency is therefore usually governed by the relative amount of direct and alternating-current load, which is to be distributed.

In cities like New York and Chicago, where over 75 per cent. of the distribution of electricity is effected by the use of direct current, the larger portion of the station capacity generates 25-cycle current, the 60-cycle current for outlying districts being derived chiefly from motor-driven 60-cycle generators.

The voltage selected for the transmission from generating station to substations should be such that the cross-section of cables, bus bars and oil switches will not be excessive. The distances are usually so short in such transmissions that the cables may be loaded up to their safe current carrying capacity without exceeding a conservative percentage of line loss.

As substation loads increase it is therefore desirable to have the voltage high enough so that the saving in the cost of conductors and switches

will more than offset the cost of extra insulation and safeguards incident to the use of the higher voltages.

In the development of such systems in American cities, voltages ranging from 6600 to 13,200 have been adopted. The lower voltages were adopted during periods when the state of the art of generator design was such that higher voltages were not permissible, though desirable from the standpoint of economy in the cost of cables, etc.

The limit of generator voltage has gradually been increasing, until at the present time manufacturers are prepared to wind generators for 20,000 volts, in units of 1500 kw. and upward.

Fig. 8 illustrates a typical distribution system of this class. A low-tension network is supplied from three substations by feeders, which are indi-

been one of the controlling factors in the extension of the direct-current systems of the companies operating in the larger cities.

The battery reserve is invaluable in a city where many thousands of people are dependent upon continuous electric service.

#### 7. Series distribution.

In this system all lamps are connected in series and operated at constant current, the voltage being varied automatically to maintain the current constant as the load varies.

This system has been quite generally used for street lighting where it is economical of copper as compared with ordinary multiple systems on account of the scattered nature of such lighting.

Where open arc lamps are used the

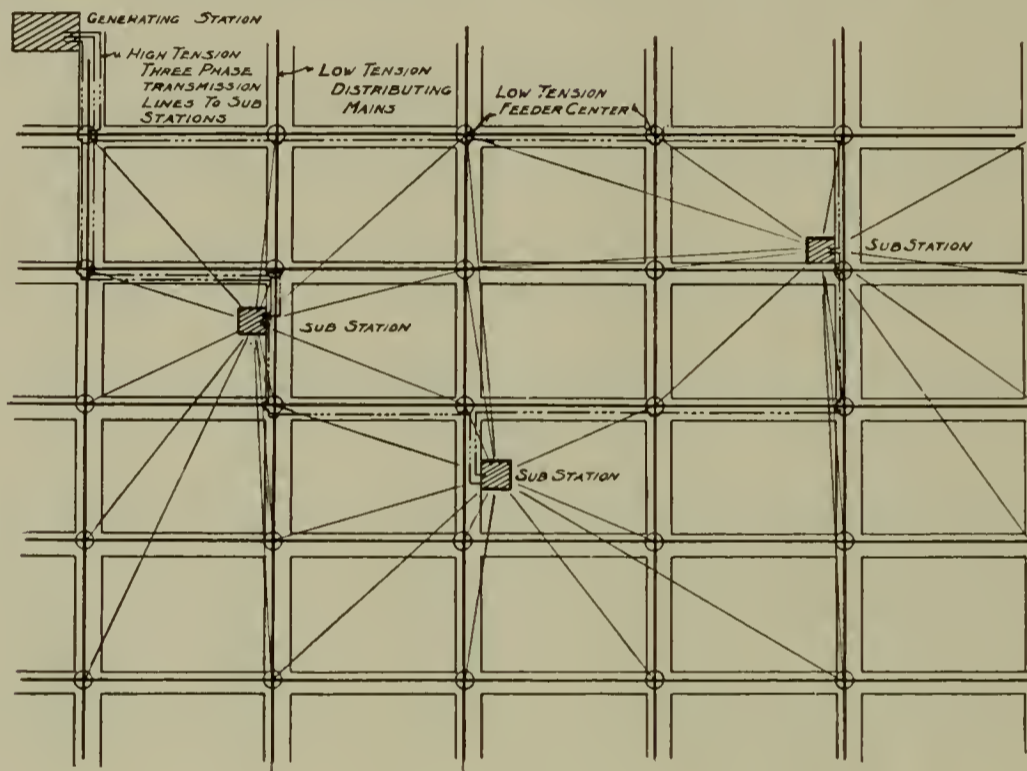

FIG. 8.

cated diagrammatically as radiating to intersecting points. The supply of direct current is derived from high potential lines through suitable converting apparatus in each substation. These transmission lines are so arranged that each substation has two sources of supply via different routes, thus insuring the substation against extended interruption of service due to failure of a transmission cable.

The substation nearest the center of the network may be provided with a storage battery auxiliary as a reserve in case of failure of any link in the chain of supply. It is also very useful as of assistance in obtaining proper pressure regulation and as an auxiliary source of electricity during the hour of the maximum load of the day.

This feature of the direct-current system of supply is not easily applicable to alternating systems and has

current strength is usually 7 or 10 amperes, the lamps consuming 50 volts at their terminals, circuits being loaded up to not more than 125 to 150 lamps.

With enclosed lamps the current strength is from 4.5 to 7 amperes, and the arc voltage about 70 volts. The voltage being limited by considerations of insulation in the lamps and circuit fittings, the maximum number of enclosed arc lamps on a circuit can be only 70 per cent. as many as can be carried with open lamps. The earlier installations were equipped with open lamps, but upon the development of the enclosed arc lamp, with its saving in cost of trimming, American practice has turned strongly to enclosed lamps, in spite of the reduction in circuit capacity thereby involved.

In Europe the lesser cost of trimming and the superior illuminating efficiency of the open arc have resulted in the retention of the open arc.



The high voltage makes this system unfit for general distribution purposes, and the constant potential systems have therefore been universally employed for general distribution purposes.

The economy of copper inherent to the series system is greatly reduced where the lighting is not scattered over a wide area. The large number of circuits required for a heavy load in a small area requires a large investment in ducts, cables and pole space, and soon reaches a point where the value of pole space and ducts occupied by the extra circuits offsets the larger section of copper in the single circuit of the multiple system.

The earlier series systems, which reached commercial form before the incandescent lamps, were designed to be operated on direct current produced by a special generator, which supplied a single circuit, or at most two circuits. The capacity of these generators was limited by the voltage, which, increasing with each additional lamp, prevented more than 125 lamps being carried on a single generator.

With the development of alternating-current systems, the expensive operation of a large number of arc

generators called attention to the possibility of the use of alternating current for series circuits.

Two general types of equipment were developed for this purpose. In one of these a transformer, taking the current at the bus voltage, is provided with movable secondary windings, which are so counter weighted as to automatically vary the voltage impressed on the circuit, and thus maintain the current constant.

In the other type a constant potential transformer is used, but the voltage impressed on the lamp circuit is varied by a choke coil in the circuit, so designed that a system of weights will keep the current constant.

Each circuit requires a transformer in the first type. A choke coil for each circuit and sufficient transformer capacity for all or a group of circuits in one unit is required for the latter type. The latter type is somewhat less expensive, more efficient and has a higher power-factor than the former, and is therefore in more general use.

In the alternating-current arc system the electricity may be generated by large and efficient units, thus avoiding the use of belts and shafting and an inefficient type of generator.

Recently a new type of lamp using a metal upper electrode and a "carbon" of "magnetite" has been developed. This lamp burns with a flaming arc of very high efficiency, and though not enclosed burns as long as the enclosed carbon lamp at one trimming. It gives about the same illumination with an expenditure of 320 watts that is given by a 10 ampere 500 watt carbon arc. It is essentially a direct-current lamp, however, and therefore requires some form of converting apparatus, such as a mercury arc rectifier, if it is used with alternating-current supply.

Series systems using incandescent lamps are used for street lighting and in special cases where no other service is available in buildings. Such systems are of value in such places as residence streets when foliage interferes with effective distribution by means of arc lamps and where a smaller unit of illumination is adequate.

The advent of more efficient types of incandescent lamp, such as the tungsten, will doubtless result in the use of series incandescent systems much more generally than heretofore.

### Electric Locomotive Rail Pressure

Experience indicates that the operation of electric locomotives, owing to their lower center of gravity, has an effect upon the track entirely different from that due to the action of steam engines. In order to ascertain the exact nature and extent of this pressure upon the rails, the motive power department of the Pennsylvania Railroad has devised the apparatus which is being utilized at Clayton.

A stretch of track about 166 ft. in length has been equipped with rails and cast steel ties, designed and made especially for this purpose. Instead of attaching the rail to the ties by spikes, a special form of block has been substituted, which allows a slight movement of the rail as the engine goes over it; this movement registers the force with which the flanges of the wheels strike or press against the rails. It is expected that a large number of experiments with this apparatus will show the company quite accurately what the effect is of either steam or electric locomotives, moving at different speeds over either straight or curved track.

Necessarily to make these tests, the engines must move at different speeds,

and at all times each attains its maximum speed.

An electric apparatus has been devised to measure the precise amount of time elapsing while the different locomotives pass over this 166 ft. of track, in order that in computing the effect upon the track the exact speed attained may be known. The steam and electric locomotives, however, go over the track at different times, and there is no element of contest as to speed between the two types. The matter of speed is purely incidental to the main purpose of the tests, which is to enable the company, in planning its electric installations in New York, to design a track so safe as to be absolutely secure against any form of locomotive that may be utilized.

### French Underground Cables

that French cities require under-Skinner calls attention to the fact

In a report Consul-General R. P. ground methods of distribution of electrical energy and that the new Marseilles cables are being laid in trenches like so much gas-pipe and with less expense and trouble. To

satisfy inquiries in regard to this subject he adds:

These modern cables, although pliant and easily handled, are really impermeable conduits of small diameter. All that I have seen are manufactured at Belfort and are delivered on huge wooden spools, from which they are unwound into the shallow trenches made ready for them with surprising rapidity. The copper wires composing these cables, arranged in groups of three, are first wound with jute, and the proper number of these groups is then wound again with jute, this cable passing next through an insulating bath. From this bath the cable passes through a lead press, from which it issues completely covered with a thin lead sheathing. The lead sheath is now covered with jute, and the cable then enters a coal-tar bath, passing next through a final bath of lime, after which it is wound upon the wooden bobbin, the lime preventing the tarry cable from adhering. The copper wires are presumed to be as secure from injury and deterioration in their lead sheath as they would be in a costly tunnel or permanent metal conduit.

## A Peculiar Turbine Trouble

**A** MOST peculiar turbine accident lately occurred at the power station of the Los Angeles Gas & Electric Company, Los Angeles, Cal. It brought out some interesting engineering points. As nearly as can be ascertained, two 2000-kw. vertical type turbines were operating in paral-

of the machine. The steam valves were open full. Almost at once buckets stripped from their discs and broke through the shell of the turbine. The diaphragm buckled heavily and the flying débris cut the steam and oil piping and disabled the pumps. As a result of the breakage of the oil

under the floor of the station with the generator end of the outfit projecting above into the station room. There might otherwise have been considerable damage to station apparatus, not to mention the serious consequences to station operators present in the room above.

It is well known to engineers familiar with this type of machine that the peripheral velocity of the moving outermost parts reaches in some machines a velocity of nearly six miles per minute. At this speed the parts are under a very high tensile stress, which approaches 25,000 lbs. per sq. in. As the tension increases with the square of the velocity, it does not require a very great increase above this speed to reach the elastic limit of steel. In fact, an increase of about 50 per cent. in speed will raise the stress to 60,000 lbs. per sq. in., which is the ordinary breaking point of cast steel. It is probable that this point was reached after the failure of the governor.



2000-KW. VERTICAL TURBO-GENERATOR IN STATION OF CALIFORNIA GAS & ELECTRIC CO., LOS ANGELES, CAL.

lel. There had been considerable surging of the load back and forth between the two machines, due, it is believed, to the sticking of the valves of the governor. Suddenly one of the machines let go, throwing the governor from its position at the top

pump, the pressure of oil at the step bearing of the second machine was lost and it came down on its step and was out of action also, though not otherwise essentially damaged.

Fortunately, at the time, nobody was in the turbine room, which is

The hunting of governors is not unknown even in steam-engine practice, but it occurs in this type of machine mainly under conditions of light load. The governor of the vertical type of turbine consists of an assemblage of admission valves tripped by cams so arranged that their crests form a spiral contour. The valves open in succession and are, of course, either entirely closed or entirely open. Thus, if there be six primary valves all tripping at full load, each valve is contributing one-sixth of the total energy. If the load be running light two valves may be admitting all the steam, dividing the load between them. Even one valve may be controlling steam for the entire machine. When there comes an increase of load, another valve trips into action, and another one follows and they drop off as the load dies off. For example, in a 2400-kw. turbine with 12 valves, each valve would admit steam equivalent to 200 kw. Suppose that the load on the machine is actually 1800 kw. at a particular moment; nine valves will be admitting steam. If the load increases to 1900, the tenth valve will begin to admit steam and the rotating spindle will now get the impact of 200 additional kilowatts of steam energy, which is 100 kw. more than the load requires. We have no longer a kinetic equilibrium between the working steam and the dragging load. We now have a uniformly ro-

tating mass subjected to an accelerating force equivalent to 100 kw. at the speed of the machine. This relatively large force produces an actual increase in speed and stores up energy in the moving turbine spindle. If now the load drops suddenly the kinetic energy of the moving spindle is sufficient to carry the load for a while, and one or more of the valves will cease admitting steam. The machine will then work temporarily under its load while the moving spindle is giving up a part of its stored energy. The governor will not readmit steam until the speed has fallen somewhat.

Suppose now there is a second ma-

chine running in parallel with the first one. When the first one begins to drop its load it will be picked up by the second machine and the transfer of energy will continue until the governor of the first machine checks up the transfer of energy, when the process will begin to reverse. Now all of this does not usually take place, except on a miniature scale, but the movements of energy may enormously increase if, for any reason, the valves are sluggish in action or actually stick.

Owing to the fact that valve admissions of steam energy are by integral parts of a considerable amount (200 kw. in the above illustration),

there is undoubtedly a hunting back and forth by the governor for the proper nozzle area and the amount of hunting is not inconsiderable for a variable load.

The rate of the governor movement is fixed, among other things, by what may be called the personal equation of the machine. There is a definite rate at which it can progress, and if a surging of the load falls approximately into this periodicity and swings with it, we have a possible condition which would seem to have actually occurred in this case, where a surging of machines not overloaded preceded the trouble.

## Electrolysis

ALBERT F. GANZ, M. E.

AT the last meeting of the Institute the committee on electrolysis, for which I had the privilege of acting as consulting electrical engineer, presented a report which contained abstracts of the most important reports and papers on the subject of electrolysis from stray currents published in America and Europe, together with conclusions and recommendations for the protection of underground pipes, and also a brief outline of the theory of electrolysis. The reports of electrolysis tests which have been published since then show generally the same results as the ones which were quoted. I can endorse the conclusions and recommendations reached by the Committee as strongly if not more strongly to-day than when they were adopted.

In the discussion of the theory of electrolysis it was stated that wherever current passes from a pipe to ground electrolytic corrosion takes place, and that a mere fraction of a volt may produce corrosion. It has been claimed by others that a voltage below  $1\frac{1}{2}$  volts cannot produce corrosion because it is below the dissociation voltage of water; this, however, is a mistake, because when current passes from iron through ground to iron and produces corrosion the counter electromotive force is only a small fraction of a volt. If current should leave an iron pipe in ground containing certain alkalis the iron

would be in what is known in chemistry as the "passive" state, and oxygen would be liberated without producing corrosion. In this case there would be a counter electromotive force of  $1\frac{1}{2}$  volts, due to the dissociation of water, opposing the flow of current in such passive places.

This passive condition of iron has also been put forward as a source of protection for iron pipes. The question has been investigated by Professor Haber,\* of Karlsruhe, who has found that this passive condition of iron rarely exists in the case of iron pipes in ground. The electrolytic effect of current leaving passive iron would in fact be to change the alkaline to an acid condition and so render the iron active, that is, subject to corrosion. If there should be both active and passive portions in a positive pipe the current would leave largely in the active places because in the passive places there is the opposing electromotive force of  $1\frac{1}{2}$  volts, so that a corresponding increased density of current and of corrosion is set up in the active places where there is practically no counter electromotive force. I cannot see, therefore, that we can derive any encouragement for the protection of pipes from this theory of the passive state of iron.

A number of laboratory investigations on the effect of alternating current in producing electrolysis have also been published, and these indicate that an alternating current will produce electrolytic corrosion which is very much dependent upon the com-

position of the soil, and which varies in amount from a fraction of one per cent. to possibly two per cent. of the corrosion produced by an equivalent direct current. It would appear from this that in certain cases, particularly in the case of a lead pipe, even an alternating current may produce destructive corrosion. No experiences with stray alternating currents have, however, as yet been made public.

In Germany a special form of electrode for measuring earth potentials, which does not introduce uncertain polarization potentials, has been used, and also a special apparatus for directly measuring the current flowing through ground. These were devised by Professor Haber, who has called them "non-polarizable electrode" and "earth amperemeter" respectively; he has used them in an extensive series of tests upon the piping system of Karlsruhe. A description of the electrode and earth amperemeter, together with the results of these tests, were presented in a paper before the Deutscher Verein von Gas und Wasserfachmannern, which is published in their transactions for 1906. These devices have also been used with success during the past year in the tests made by the German electrolysis committee.

The mode of testing a piping system for stray currents is of considerable importance and interest to gas engineers. As this was not touched upon in the report of last year, I will in what follows endeavor to give an outline of suitable methods for making such tests, and also briefly describe the construction and uses of

NOTE.—A lecture delivered before the American Gas Institute, Washington, D. C., October 17, 1907.

\*See *Zeitschrift Für Elektrochemie*, January 26, 1906.

the new German devices. I will lay special stress on methods which will serve to prove that corrosion was due to stray currents and to prove the origin of these currents so as to fix the responsibility, as this is important and essential evidence in case of a law suit!

With the arrangement, usual with trolley roads, of connecting the negative terminal of the generator to the rails, the general path of the stray currents is from the rails through ground to the pipes at places distant from the power-house, through the pipes, and from these through the ground back to the rails or to other return conductors in the vicinity of the power-house. Where current flows from a rail to a buried pipe the rail assumes a positive potential with reference to the pipe; where current flows from a buried pipe to a rail the pipe assumes a positive potential with reference to the rail.

The first step in making an electrolysis survey of a piping system is therefore to measure potential differences between pipes and rails in a large number of places throughout the system in order to locate these points of current flow between pipes and rails. As gas mains are not generally accessible, service or drip connections are used for making connection with the voltmeter; for this purpose one voltmeter wire is clamped or otherwise fastened to the drip or service connection, care being taken to clean with a file the part where the wire is fastened so as to insure good metallic contact. The other voltmeter wire is best soldered to a rough flat file which is held on the rail for the contact, and which can be quickly removed and replaced when a car passes. The voltmeter for these measurements should have a high resistance so that an accidental poor contact at a drip or service connection will not seriously interfere with the measurement. A suitable instrument is a portable high resistance Weston voltmeter with zero center, having ranges of 1.5, 15 and 150 volts. Readings should be taken every 10 seconds for 10 minutes at each point, and the maximum, minimum and average reading noted.

The average readings are then conveniently marked upon a map showing the principal pipes and tracks, red numbers being used where the pipes are positive to the rails and black or blue numbers where these are negative. An excellent plan is also to plot these potential differences graphically upon a map on which the pipes are shown as lines and using these lines for axes, and the voltmeter readings for ordinates; by shading the areas between the potential curves

and the pipe lines with red where the pipe is positive and with black or blue where it is negative to the rails, a clear representation of the potential distribution is obtained. If the negative bus bar of the power station is connected to ground plates or to other buried metal as cable sheaths, measurements of potential differences between these and the pipes should also be made and plotted upon a separate map.

It will generally be found that there are definite regions in the neighborhood of supply stations and of return feeder connections in which the pipes are always positive to the rails; and that there are other definite regions, remote from the first, in which the pipes are always negative to the rails. Between the positive and negative regions the potentials will be found to fluctuate from positive to negative.

The existence of potential differences between pipes and rails, even if large, is however no conclusive evidence of stray currents, but indicates at what points current may be flowing from rails to pipes and at what points it may be flowing from pipes to rails or to other return conductors. A

covered wires so as to have a good insulation and to prevent the wire, if coming in contact with wet ground, from taking the potential of the ground and disturbing the readings. A good wire for this is No. 14 rubber-covered and double-braided wire. I remember one instance where we were measuring the drop along a cable sheath on a wet day, getting readings of from one to two millivolts; during one of these readings the needle suddenly ran off the scale, and a voltmeter which was substituted indicated two volts. We found upon investigation the connecting wire lying in water, the insulation defective, and that we were therefore getting the potential difference between the cable sheath and the surface of the ground instead of the drop in the cable sheath.

A study of the map will show at what points determinations of current strength should be made. This is done by measuring the drop in potential between two points in the pipe by means of a millivoltmeter, and dividing this by the resistance of the included length of pipe. If this length contains one or more joints this resistance must be measured and not

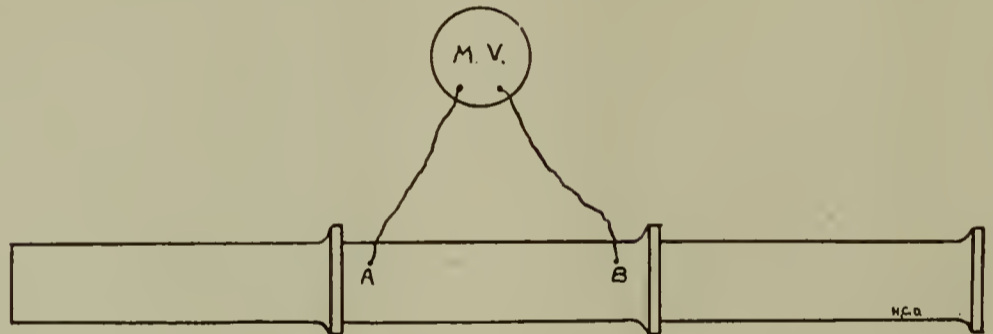

FIG. 1.—CONNECTIONS FOR MEASURING CURRENT IN MAIN.

high potential difference is, in fact, usually a sign that there is a high ground resistance and but little current flowing.

The next step is to determine the direction of the probable current flowing in the pipes. This is done by measuring potential differences between two points in a pipe by means of a millivoltmeter. A convenient instrument for these measurements is a zero center Weston millivoltmeter with two scales, one of 10 and the other of 100 millivolts. These measurements may be made between drips or service connections from 50 to 200 feet apart. These measurements cannot be used, however, for calculating the current strength in the pipes but only to indicate the probable existence and direction of this current. This direction of flow is then marked upon the map together with the potential readings.

In making these tests it is important that the connecting leads used with the millivoltmeter be rubber-

estimated, because joints make contacts of extremely variable resistance. As this resistance measurement is troublesome to make, it is generally more convenient to measure the drop in potential between two points in one continuous length of pipe. A sketch of this arrangement is shown in Fig. 1. With very large pipes and small current this drop is a fraction of a millivolt, and requires a specially sensitive millivoltmeter reading to hundreds of a millivolt for its measurement. The resistance of the length of pipe can be calculated from its dimensions and from an assumed figure for the conductivity. Mr. Maury, in a paper\* before the American Water Works Association, has given convenient tables for converting drop in millivolts directly into amperes of current for cast iron and for wrought iron pipes. These tables are based upon a resistance of 0.00144 ohm per

\*"Surveys for Electrolysis and Their Results." A paper read at the Twenty-third Annual Convention of the American Water Works Association, held at Detroit, Mich., June 23-26, 1903.

pound-foot for cast iron and of 0.000181 ohm per pound-foot for wrought iron; these figures were obtained from measurements upon a large number of pipes, and agree well with these given by others and with measurements made by the writer. To find the resistance of any cast or wrought iron pipe per foot of length, it is only necessary to divide the above figures by the weight of the pipe per foot. In the accompanying table I have given the weights and resistances per foot for the usual sizes of cast and wrought-iron pipes, the resistances being based upon the above figures for the pound-foot.

tained by soldering the connecting wire directly to the pipe; this is particularly advantageous when readings are to be taken over a considerable time. This soldering should be done by means of a torch and sufficient time allowed for the joint to cool to the temperature of the pipe before using it, as otherwise a thermo-electromotive force may be set up which disturbs the reading. When such contact wires have been soldered to a pipe it is convenient, whenever practicable, to continue these with rubber-covered wires to the surface, or to some accessible point, and to terminate the ends in small iron boxes

this reason that stray currents represent no loss of electricity to the railroad, as is sometimes supposed, but are, on the contrary, a gain, inasmuch as the ground and pipes offer additional return paths for the railway current and therefore mean less drop in the return circuit. It is for the purpose of taking advantage of the earth as a return conductor that railway power stations frequently use large ground plates connected to the negative bus bar with heavy copper cables.

The previous brief outline of tests will serve to locate the points in the positive district in which there is the greatest danger from electrolytic corrosion, and these tests are relatively easily made and constitute the electrolysis survey as ordinarily made in America.

There may, however, be many other endangered points which these simple tests will not reveal. Stray currents do not always take the simple path from rail to pipe, along the pipe and back to rail or other return conductor, but frequently take roundabout paths, passing from one piping system to a second system, from this, perhaps, to a third system, or passing across pipes, shunting around high resistance joints, etc., producing electrolytic corrosion at every point of leaving the pipe for ground. These points may exist in the negative, neutral or positive districts, and are much more difficult to locate by means of electrical measurements.

WEIGHTS AND RESISTANCES OF CAST AND WROUGHT IRON PIPE

Inside Diameter of Pipe Inches	STANDARD CAST IRON		STANDARD WROUGHT IRON		EXTRA HEAVY WROUGHT IRON	
	Weight per Foot without Hub Pounds	Resistance per Foot Ohms	Weight per Foot without Hub Pounds	Resistance per Foot Ohms	Weight per Foot without Hub Pounds	Resistance per Foot Ohms
1/2	.....	.....	.84	.000215	1.1	.000164
1	.....	.....	1.7	.000106	2.2	.000082
1 1/2	.....	.....	2.7	.000067	3.6	.0000502
2	.....	.....	3.6	.0000502	5.	.0000362
3	11.	.000131	7.5	.0000241	10.	.0000181
4	18.	.000080	10.6	.0000171	15.	.0000121
6	31.	.0000465	18.8	.00000963	29.	.00000623
8	42.	.0000343	28.	.00000647	43.	.00000421
10	55.	.0000262	40.	.00000452	54.	.00000335
12	70.	.0000206	49.	.00000369	65.	.00000278
16	109.	.0000132	.....	.....	.....	.....
18	130.	.0000111	.....	.....	.....	.....
20	151.	.00000955	.....	.....	.....	.....
24	205.	.00000702	.....	.....	.....	.....
30	294.	.00000490	.....	.....	.....	.....
36	408.	.00000353	.....	.....	.....	.....
48	604.	.00000238	.....	.....	.....	.....

A matter of great importance in making these current measurements is to be sure to have perfect metallic contact between the pipe and the millivoltmeter wires. It will not do to use drip or other fittings for this connection, but contact must be made directly with the metal of the pipe. It is therefore necessary to expose the pipe where a current measurement is to be made.

I have made tests with various methods of making contacts for current measurements upon a rusty pipe, and have found that the presence of oxid may produce such a high resistance as to prevent a reading. I have also found that moisture can produce an electromotive force due to electrochemical action so large as to entirely offset the reading due to drop by the current. A satisfactory method is to use a pointed piece of steel about half the size of an ordinary lead pencil, with the connecting wire soldered to it, and provided with a wooden handle, the soldered joint being inside of the handle; this steel contact is pressed against a spot on the pipe which has been previously filed bright. By far the best contact is however ob-

such as drip boxes; these wires are then available for future current measurements on the pipe without going to the labor of again exposing it.

These readings of current should be taken every 10 seconds for at least 10 minutes, and the maximum, minimum and average readings noted.

By tracing the flow of currents found in the pipes from these measurements points can be usually located at which current must be leaving the pipes, and the pipes should be exposed here and examined for evidences of electrolytic corrosion. It must be remembered that all current which is found flowing in a pipe must leave it somewhere in order to return to the negative pole of the generator. This follows from the fact that every electric circuit must be completely closed so that every ampere which leaves the positive pole of the generator must eventually return to the negative pole, no matter how long or complicated the path through which it passes may be. Electricity is in this respect very different from gas or water, which latter may escape from a leak and diffuse through the ground. It is for

The writer has in mind a striking case of this kind which he saw while witnessing some tests made by Mr. A. A. Knudson, in Rutherford, N. J. A water pipe crossing under trolley tracks was badly corroded, with all evidence that the corrosion was electrolytic, yet this pipe was always over one volt negative to the rails and therefore could not be giving up current to these rails. Upon further investigation it was found that an oil pipe crossed this water pipe several feet away in the ground, and that the water pipe was highly positive to this oil pipe. It was therefore clear that the current which was producing the corrosion was leaving the water pipe and entering the oil pipe.

Wherever there are two or more independent piping systems, as for instance water and gas pipes, measurements of potential difference between these should be made to see if any points can be located where current is likely to be passing from one to the other. Current measurements must then be made in the pipes at these points and plotted and studied as before.

Measurements of current should

also be made at every point where a pipe crosses a trolley track or passes through particularly wet ground near trolley tracks, to see whether current is passing from one to the other, as these are particularly endangered points. For this purpose it is best to expose a length of pipe on each side of the track and to measure the current on each side. It may be found, however, that this current is so fluctuating that it is difficult to draw conclusions from these readings; the

where it passes under the track, and therefore if current is passing from pipe to rail or from rail to pipe at this point. The same method may be applied in any case where it is desired to find out whether there is a change in the current flowing in a pipe between any two points in the pipe. The illustration (Fig. 2) shows two such simultaneous current readings taken in a pipe on each side of a stretch of wet ground in which the pipe was laid for a distance of about 500 feet

B, the curves showing that during most of the time the test current was entering the pipe from the wet ground between these stations.

In making these simultaneous current measurements it is very important that the two millivoltmeters have the same period of oscillation, as otherwise, with the usual fluctuating current, one would lag behind the other in its reading, and the instantaneous readings would no longer be comparable. It is desirable to use

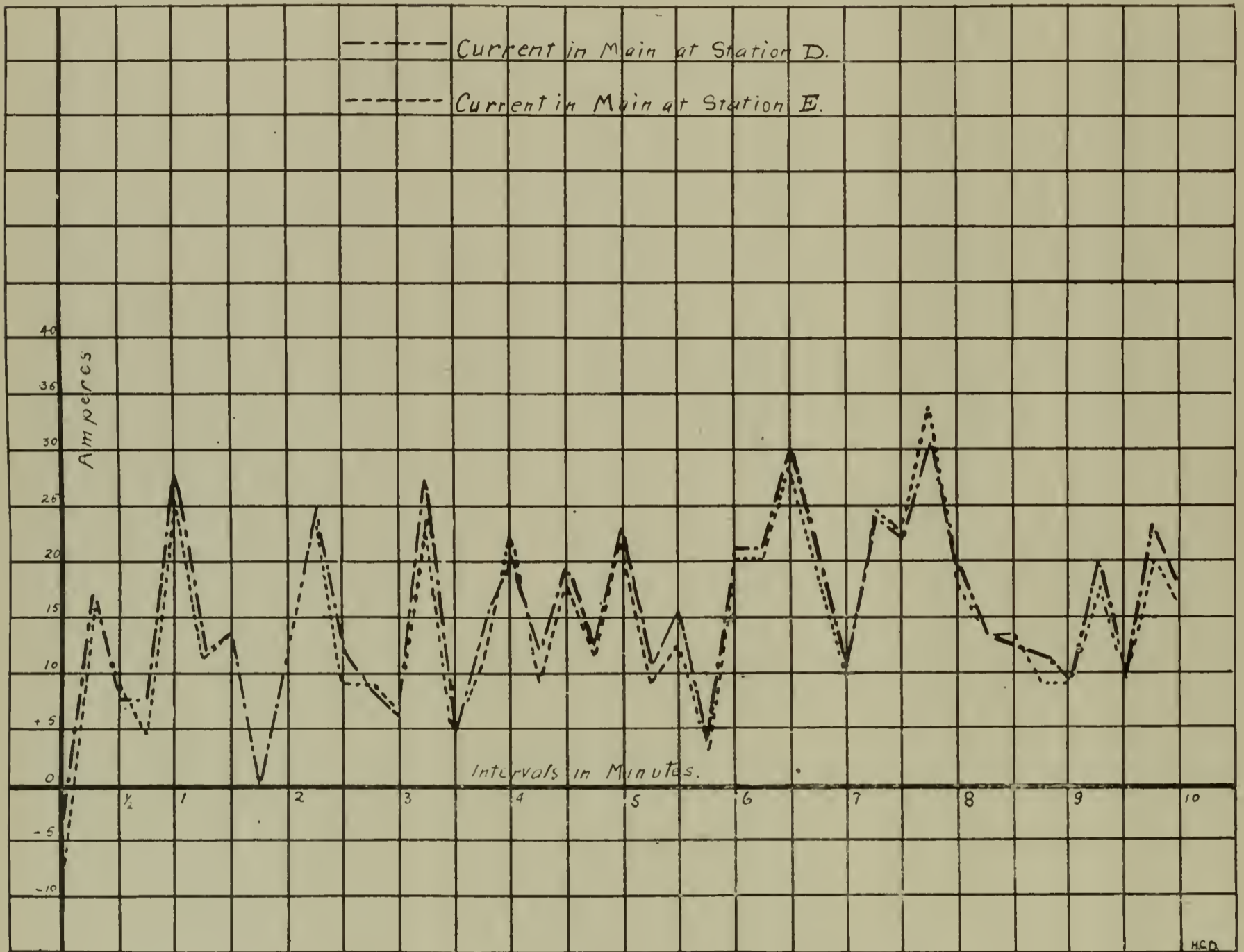

FIG. 2.—SIMULTANEOUS CURRENT READINGS AT TWO STATIONS IN A GAS MAIN.

passing of a car may produce an entire change in the current conditions. I have found that the best way to make the test under these circumstances is to use one millivoltmeter on the pipe on each side of the track, and to take simultaneous readings of current every 10 seconds for 10 or 20 minutes. The time of taking these readings should include the passing of a car. When these readings are plotted it can be seen by comparing the current curves whether there is a change in the current in the pipe

and only one-half block away from trolley tracks; the agreement of the current curves shows, however, that current was neither passing to nor from the pipe in this wet ground during the time of these tests.

A case where current was entering a pipe from wet ground is shown by the curves in Fig. 3, in which the simultaneous current readings are plotted, taken on each side of the wet ground through which this pipe was passing. The direction of the current flow was from Station A to Station

two exactly similar meters, and these should be strongly damped so as to move slowly enough to enable accurate readings to be taken even with a very fluctuating current.

Another very important matter is the choice of time for making these measurements. The stray currents in the pipe will follow the load curves of the railway, and tests should be made at time of heaviest load as well as at times of light load.

In a large railway system operating a number of stations, some of the sta-

tions may be shut down during periods of light load, and the current condition in the pipes be completely changed during these times. If the stray currents in the pipes are the combined leakage current from two or more railway systems, having different load curves, the current conditions in the pipes will also change during different times of the day, and perhaps also on different days. In cases of this kind a recording meter should be applied to a number of

as shown for Monday and Tuesday in Fig. 4. The diagram for Sunday shows that the current in the pipe was very large, and flowing practically all day in the same direction; this large current is accounted for by the fact that the neighboring trolleys were carrying a large crowd of Sunday excursionists. The following Sunday was a rainy day, and the record showed a much smaller current in the pipe for this day. I want to say that the change in direction of the current

the probable destruction. One ampere leaving an iron pipe for wet soil will remove 20 pounds of iron in one year. But the same ampere of current in its path through the ground and pipes may leave the pipe and return to it any number of times, shunting, for instance, around occasional high-resistance joints, and removing iron at the rate of 20 lb. per year at every point of leaving the pipe. The actual damage is also very much dependent upon whether the exit of cur-

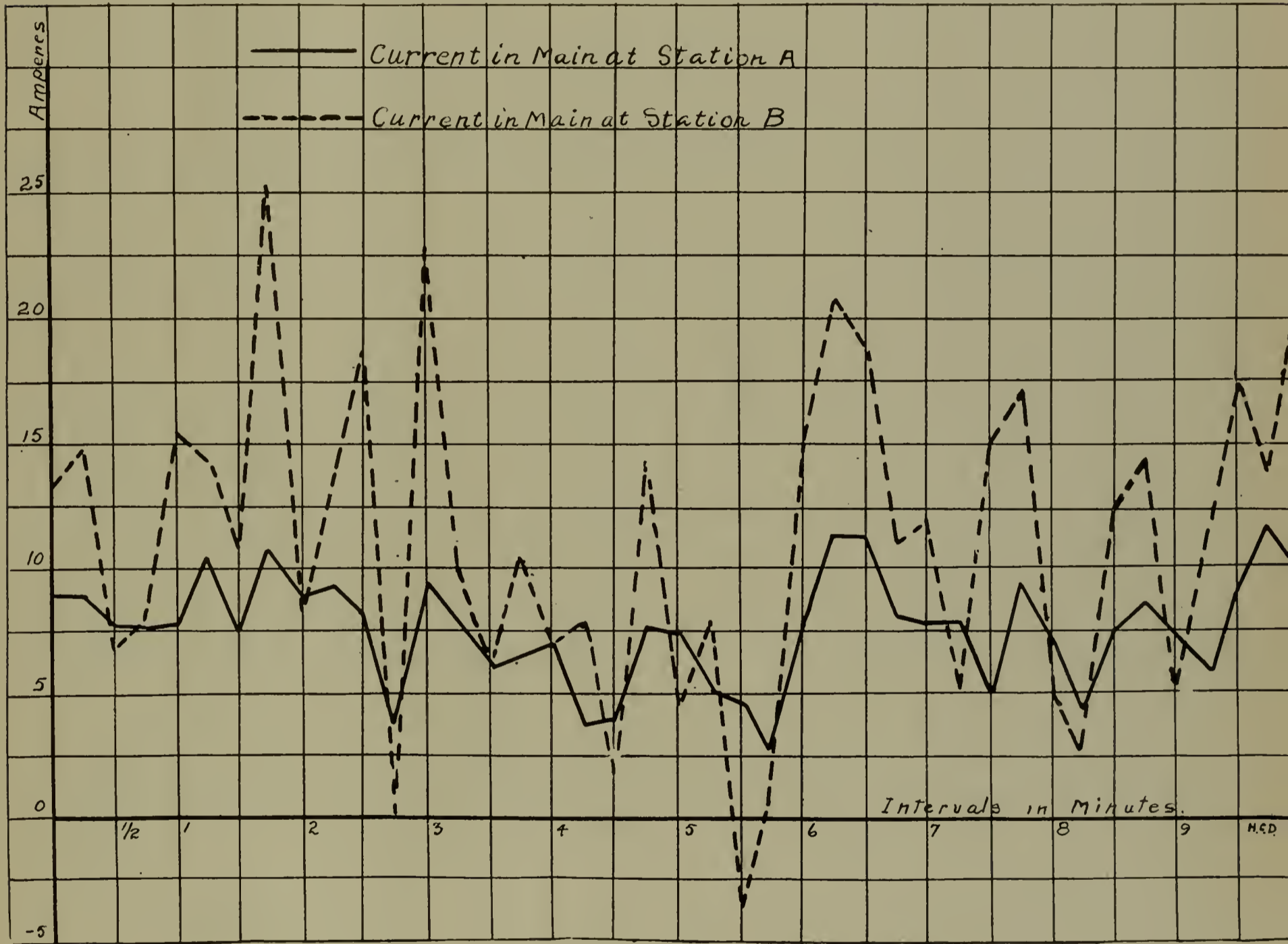

FIG. 3.—SIMULTANEOUS CURRENT READINGS AT TWO STATIONS IN A GAS MAIN.

characteristic points in the piping system, arranged to record the current in the pipe. I have used a Wm. H. Bristol recording meter (a pyrometer instrument without its thermo couple) to obtain 24-hour records of currents in pipes. The diagram in Fig. 4 shows the current in a gas pipe for four consecutive days, obtained from four Bristol charts by estimating the average current for consecutive one-hour periods and plotting these averages. The records for other week days were about the same

indicated in the week-day diagrams is an unusual condition, and probably due to changes in the operation of the power-houses producing the currents affecting the pipes. These current records, by their agreement with the load curves of the trolley road, are frequently also useful in serving as evidence that the currents in the pipes are trolley-road currents. As the electrolytic damage is proportional to the time during which the current acts, it is necessary to have the time curve of current in order to estimate

rent is concentrated in a small area or is distributed over a large area. Experience shows that the electrolytic corrosion ordinarily takes place in spots, producing pittings in the pipes, which indicates that the current must leave the pipes in these spots and not from the entire surface; the pipes are in this way much more quickly destroyed than if the corrosion took place uniformly over the entire surface. It therefore is an extremely difficult matter to estimate the amount of electrolytic damage and such esti-

mates will generally be too low for the above reasons.

It is possible to trace the path of current through the ground by measuring potential differences between different points in the ground. An iron rod driven into the ground is often used for making contact for such measurements. This, however, is not reliable because the electromotive force of polarization of the iron in wet ground is dependent upon the surface condition of the iron and upon the ingredients of the ground; it is not constant, and not necessarily

against the part of the ground at which the potential is to be measured, thus establishing contact between the ground and the zinc sulphate solution. There is only a negligible polarization voltage between the zinc sulphate and ground. The zinc in this solution has a definite and constant polarization voltage with reference to the solution. When two of these electrodes are used to measure the potential difference between two points in the ground, the two polarization voltages balance each other. With these electrodes a zero method,

by in the ground would be 0.45 volt, the pipe being positive. If then a measurement shows the pipe say 1.1 volt positive to the electrode it means that the pipe is  $1.1 - 0.45 = +0.65$  volt (positive) to the ground and proves that current is flowing from the pipe to the ground. If a measurement shows a pipe say 0.15 volt positive to the electrode, it means that this pipe is  $0.15 - 0.45 = -0.3$  volt (negative) to ground and proves that current is flowing from the ground into the pipe. Ground potentials of less than one-tenth volt cannot safely be used as

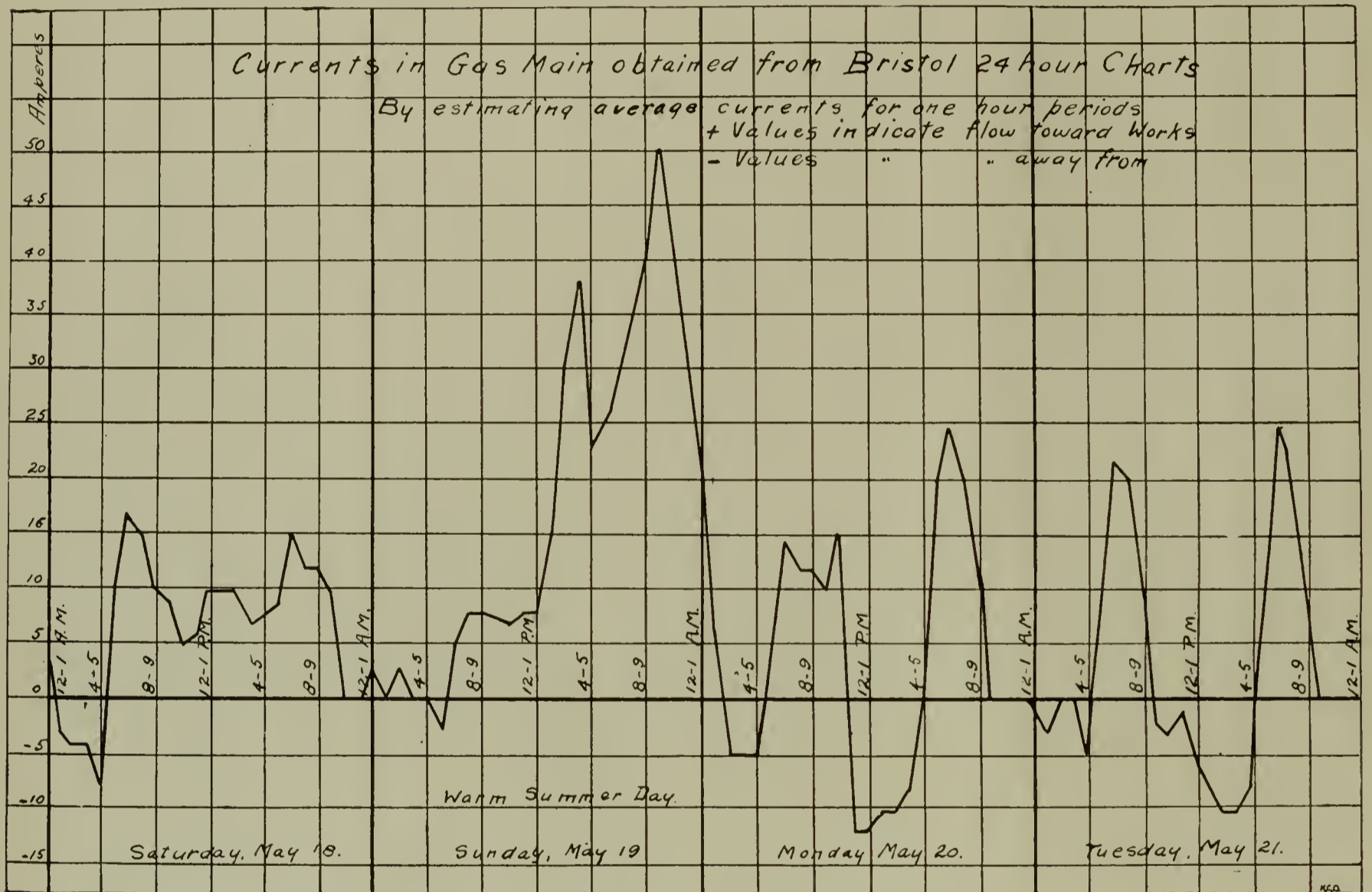

FIG. 4.—RECORD OF CURRENT IN A GAS MAIN FOR FOUR CONSECUTIVE DAYS.

the same for each of two rods in different parts of the ground. Where small potential differences are measured between two points in the ground by means of iron rods as electrodes entirely wrong results may be obtained because of difference in the polarization voltages at the two electrodes.

To overcome this difficulty the "non-polarizable electrode" shown in Fig. 5 was devised by Professor Haber. This consists of a glass tube about two inches in diameter and 10 in. long, having a porous cup cemented to one end, and containing a saturated solution of zinc sulphate with a zinc rod dipping into the solution. The porous cup is pressed

such as a potentiometer with a sensitive galvanometer, should be used for measuring the potential differences, because the high resistance of the contact through the porous cup would produce a drop in voltage and reduce the reading on a direct-reading voltmeter. This non-polarizable electrode is also used to measure the potential difference between a pipe or rail and the ground; in this case the polarization voltage of the electrode must be taken into account, which is equal to 0.45 volt negative with reference to the iron of a pipe or rail. This means that without current flowing between pipe and ground the potential difference between an iron pipe in ground and this electrode placed near-

evidence of current flow as they may be due to accidental causes.

It may be desirable to measure directly the flow of current through ground as between a pipe and a rail, or between two pipes. The best arrangement for this is the "earth amperemeter" devised by Professor Haber and illustrated in Fig. 6. This consists of a wooden frame with two copper plates about four inches square and separated by a plate of mica or glass as shown in the figure. These copper plates are covered with a layer of a paste made of copper sulphate and water with 20 per cent. sulphuric acid, the thickness of paste being about  $\frac{1}{16}$ -inch. A wetted piece of parchment paper is laid over this



paste and the remainder of the frame is filled with soil taken from the portion of ground where the current is to be measured. This frame is then placed in a suitable excavation in the ground where current is to be measured, so that the current flow is as nearly as possible normal to the frame, and the latter is then completely covered up, the soil being tightly stamped in. Insulated copper wires are brought out from the plates and connected with a milliamperemeter; this will indicate the current flowing through this section of the ground. The object of the copper sulphate paste is to prevent polarization at the surfaces of the copper plates, which otherwise would produce an electromotive force opposing the flow of current through the meter. The direction of the meter indication will give the direction of the current flow through the ground. It might be supposed that the introduction of this frame would entirely change the current conditions in the ground; this has not been found to be the case, due to the fact that the resistance of the path through the ground is very high; the displacement of the small portion of ground taken by the copper plates therefore does not greatly change the total resistance of the path of the current through the ground. The notion that the earth is a conductor of negligible resistance applies only when the path of the current is through an unlimited cross section; the resistance of a limited section of earth is comparatively high, varying under ordinary conditions from 100 to 1000 ohms between opposite faces of a cubic foot.

This earth amperemeter is well suited for measuring current flow between pipe and ground; for this purpose the frame is buried in the ground from one to two inches from the pipe, and parallel to the pipe and normal to the probable current flow through ground. This measurement can be used to form an estimate of the probable amount of electrolytic damage to

I want to call attention to a wholly incorrect method for determining current flow between pipes and rails

tween a point in the rails and a point in the pipes is measured with a voltmeter, as between *C* and *D* in Fig. 7, and the resistance between these same points is measured with an ohmmeter; the voltage divided by the resistance is given as the current in amperes flowing through the ground. This is then repeated for other points, as *E* and *F*, *G* and *H*, etc. (Fig. 7), and these currents are added up to give the total current through the ground. In one published report of this class upon a water piping system in a Western city, this total current is given as 6148 amperes, with a calculated destruction of 122,980 lb. of iron per year. The following words of warning are found in this report: "The loss of 122,980 lb. of metal per year from the distributing water system must eventually bring great and serious trouble, involving the expenditure of many thousand dollars." The absurdity of these figures is clear when we consider that many times this current could have been obtained by making tests in a sufficient number of additional points in the system. Current through ground between pipes and rails cannot be determined from such measurements of potential difference and ground resistance. The latter is the joint resistance of all conducting paths between the entire piping system and the entire rail system, while the potential difference is that between a point in the pipes and a point in the rails; these two measurements can therefore not be combined by Ohm's law to give current, and the figures which have been given in the reports referred to are entirely without meaning; the results and conclusions based upon them are consequently wholly untrue.

As an example of the wholly in-

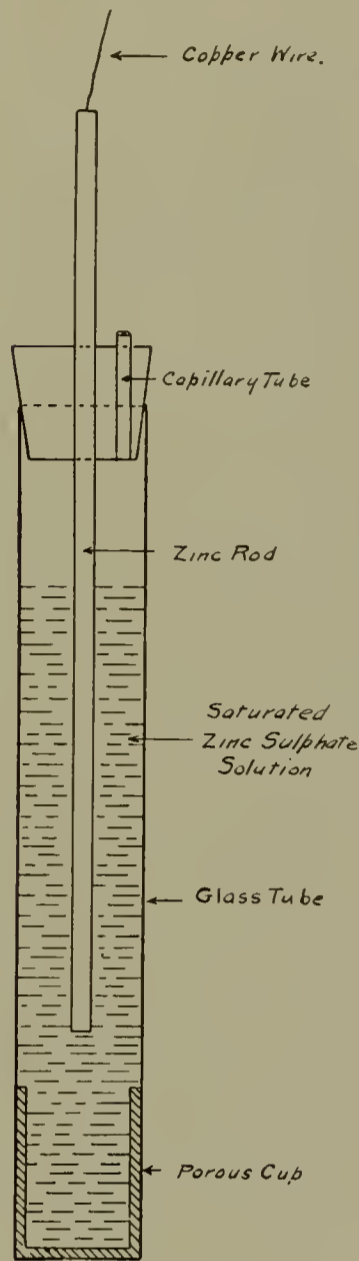

FIG. 5.—NON-POLARIZABLE ELECTRODE.

through ground, which I have seen described in a certain class of electrolysis reports. I refer to the method in which the potential difference be-

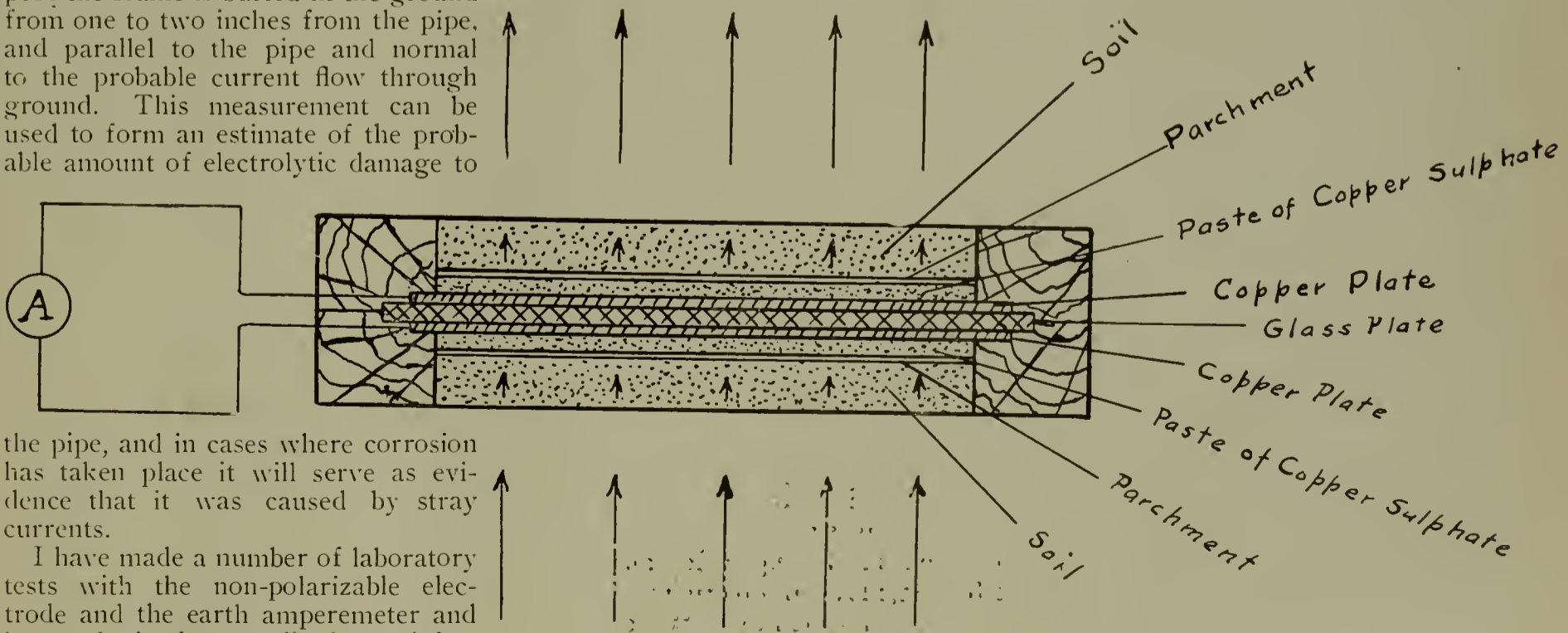

FIG. 6.—EARTH AMPEREMETER.

the pipe, and in cases where corrosion has taken place it will serve as evidence that it was caused by stray currents.

I have made a number of laboratory tests with the non-polarizable electrode and the earth amperemeter and have obtained exceedingly satisfactory and consistent results.

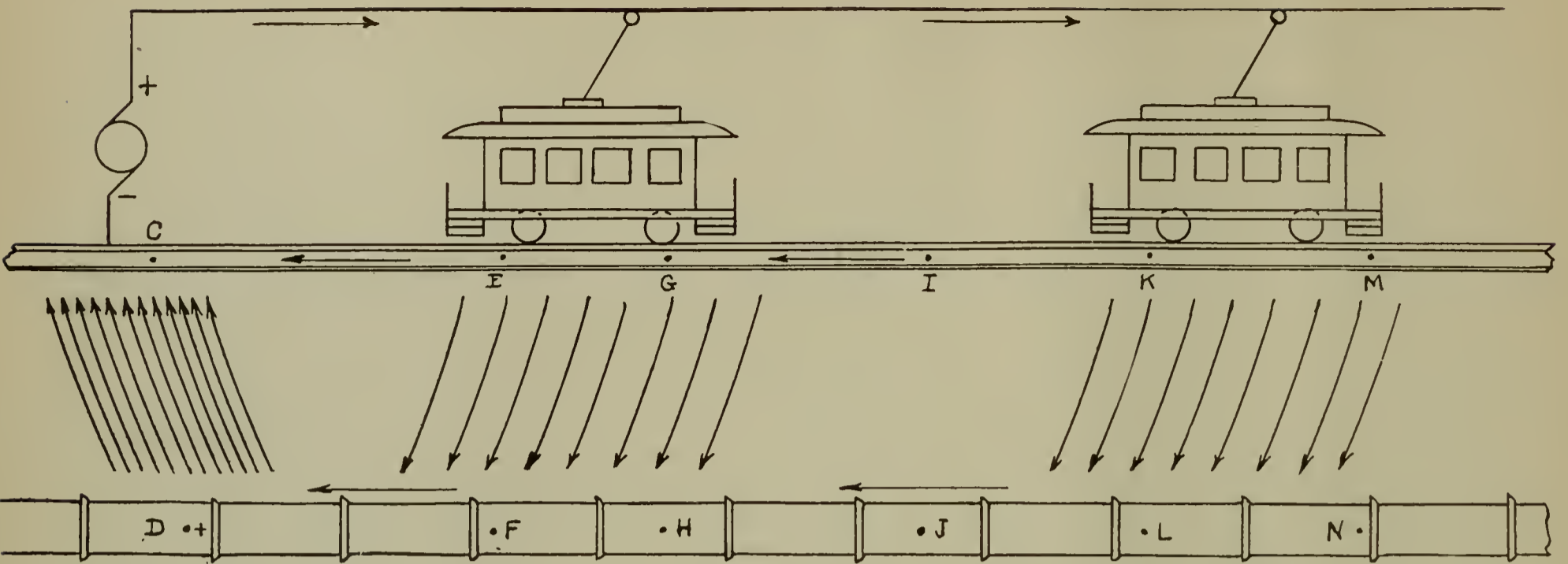

FIG. 7.—DIAGRAM SHOWING PATH OF STRAY RAILWAY CURRENTS.

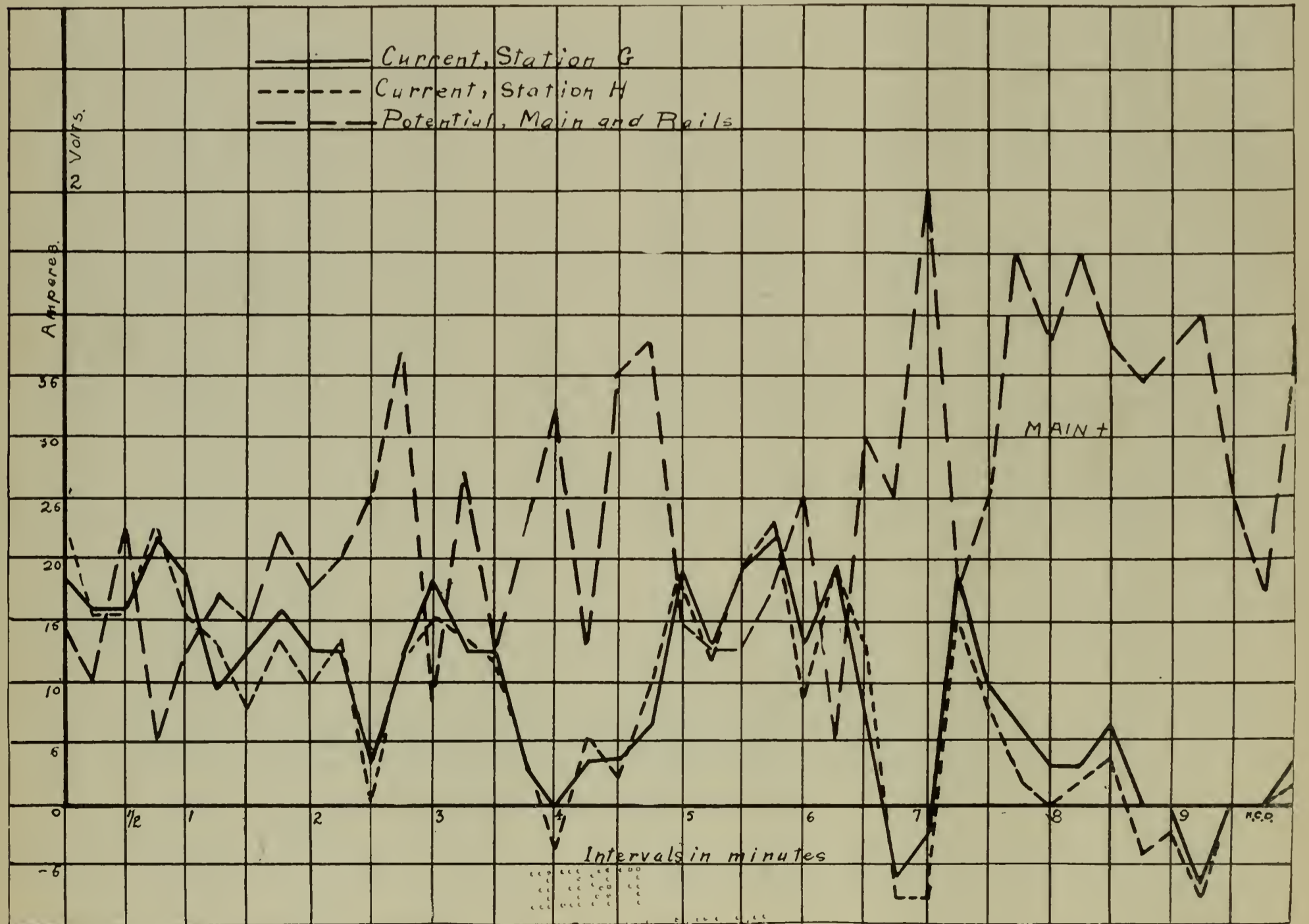

FIG. 8.—SIMULTANEOUS READINGS OF CURRENTS IN GAS MAIN AND OF POTENTIAL DIFFERENCES BETWEEN MAIN AND RAILS.

correct conclusion which this method may lead to, I have shown in Fig. 8 the instantaneous values of current measured in a gas pipe at stations on each side of a stretch of ground soaked with salt water, taken simultaneously with potential readings between this pipe and trolley tracks close by and in contact with this wet ground. The gas pipe is seen to be about one volt (average) positive to the rail. The resistance between the rails and pipe must be very low so that a current calculated by the above method would give a large value and lead to the conclusion that this current was passing from the pipe to the wet ground and producing corrosion. The simultaneous current readings show, however, that there is practically no escape of current from the pipe between these stations. This class of report is generally also full of remarkable statements which greatly exaggerate the electrolysis danger and which seem to be designed to scare people against the electrolysis evil. From the absurdity which appears on the face of these reports they tend to hide the real electrolytic conditions and the real dangers which exist. The technical press has already exposed and severely criticized some of these reports which have been published.

Where more than one electric road is operating in the vicinity of a piping system, the stray current in the pipes may be the leakage current from one, or it may be the sum of the leakage currents from all of the roads. In cases where electrolytic damage has resulted it is important to trace and prove the source or sources of the

destructive current in order that claims for damages and a demand to stop this current may be presented to the proper owners, and pressed in court if necessary. This is fairly simple if it is possible to disconnect one power-house at a time sufficiently long to measure the effect upon the pipe current. If this cannot be done indirect methods must be used which may make the problem very troublesome, especially in cases where two or more roads use a common track for part of their line. Noting the starting, running and stopping and location of the cars on each line, and comparing this with the current curves in the pipes, will often help to locate the source or sources of the pipe current. Where the tracks of the different roads are independent, a good method is to attempt to measure the current flowing through the ground between pipes and the rails of each system by means of the earth amperemeter. No universal method can, however, be given because the conditions vary so widely; it is necessary to study each case separately and to adapt the methods best suited to it.

Of the attempted remedial schemes the one most frequently applied to pipes in America is bonding in the positive districts to the negative bus bar. While affording local protection, this greatly increases the amount of stray current, frequently producing electrolytic trouble in other portions of the piping system, as at joints, and the pipes themselves become a source of danger to other underground metal. In cases where there are variations in current flow, as was, for instance,

illustrated in Fig. 4, no bonding scheme can be applied, as the positive zones keep shifting about.

Insulating joints can only be used in special cases to effect a partial reduction in the stray currents in the pipes, and often do more harm than good.

I am convinced that in most cases there is but little, if anything, that the pipe owner can do to protect his pipes from these stray railway currents. The cure must and in all fairness should come from the railways. This is the attitude which the Germans have maintained ever since they have begun to study this problem.

The question of the proper restriction to place upon the railroad in order to render underground piping reasonably safe from stray currents is a hard one to settle. In some places a maximum permissible potential difference in the rails, or between rails and pipes, has been prescribed by city ordinance. The amount of stray current depends, however, just as much upon soil resistance as upon potential difference, and this resistance varies so largely that no maximum, safe voltage can be prescribed for all cases except one so low as to be entirely impracticable. The maximum allowable current in any one pipe is sometimes prescribed; this, however, is also inadequate. The only really safe condition would be a maximum allowable density of current leaving any one pipe for ground expressed in milliamperes per square foot of pipe surface. This is, however, troublesome to measure, and the restriction would be very difficult to enforce.

## An Odd Case of a Motor Dropping Its Load

A 10-h.p., 110-volt, direct-current motor received its current from an engine-driven generator, the engine being also belted to drive shafting. The motor was connected to this line shafting by a chain drive. The purpose of this arrangement was to test power chains.

By weakening the field of the motor its increased speed allowed it to return power to the shafting through its chain drive. The work done by the chain under test is varied by changing the field strength of the motor.

After several years of successful operation in the above manner the motor became inoperative. Within a few minutes after starting it up and weakening its field to allow a flow of current corresponding to the torque

required, it would be found that the current, for some unaccountable reason, had dropped nearly to zero and the motor would be simply floating on the line without transmitting any power to the shafting through the chain drive. There was about  $\frac{1}{8}$ -inch end play of the shaft, and by pressing slightly on either end of the shaft so as to stop the end motion, the current taken by the motor and consequently its torque would raise immediately from zero to normal. The motor was then operated as a generator, receiving its power from the shafting through the chain drive and feeding into a bank of lamps. With the shaft oscillating normally the voltage of the generator was 110, but by pressing on the end of the shaft (thus preventing

any end play) the voltage immediately rose to 115 volts.

It was found that two of the four brush-holders were carrying double the amount of current carried by the other two, although a voltmeter placed across each of the four field coils showed the same voltage drop across each coil.

The trouble was found in one of the field coils, which had a broken wire in its center. When the shaft was not allowed to oscillate the broken wire laid together and the motor operated normally, but when the shaft oscillated the vibration of the motor, due to the pounding of the collar on the motor shaft against the bearing, caused the perplexing action we have just noticed. A new field-coil cured this trouble.

# The Application of Electric Power to Pulp and Paper Mills

Le ROY M. HARVEY

THE wonderful progress made in the last decade, particularly during the last five years, in the application of electricity as a motive power to all branches of commerce

fogies in the business, and I am ashamed to admit it, but we are waking up, and in a few months' time you won't find any conditions like this, in my mill at least. The trouble with us

reason why we should change these conditions. We simply let well enough alone."

The above statement undoubtedly offers the only possible excuse for the existence of such poor devices for power transmission in an age when much better ones are realized facts, but with the rapid increase in the number of paper mills within the last few years, and the keener competition resulting therefrom, it has become a necessity to reduce the cost of production, and this without lowering the quality of the product. To secure low cost of production means not only an economical administration of all the affairs of the mill, but also the adoption of the modern labor and power-saving apparatus and devices. The best managed mill in the country, if it is handicapped by an antiquated equipment, cannot hope to compete with a modern mill operating under improved conditions.

No line of improvement in paper-mill equipment will contribute more



FIG. 1.—THE WATAB PULP AND PAPER CO., VIEW OF MILL FROM UP-STREAM SIDE.

and industry, has awakened the interest of the whole manufacturing world to its possibilities, and the paper-mill operator, like his brother manufacturers in other lines, is today making a conscientious investigation into the results to be secured by the application of this power to his own particular branch of industry.

The scheme of power transmission which has prevailed in paper mills has a parallel in that to be met with in any other factory of equal or greater size not already equipped with electric motors. A distinguishing difference, however, between the paper mill and the other types of factories is found in the fact that in possibly no other industrial establishment is the percentage of losses due to an inefficient system of power transmission so great as in the paper mill; and, as a consequence, in no other type of industrial establishment is the per cent. of saving resulting from electrical equipment so large. A short time ago a prominent paper manufacturer of the Middle West said, in answer to an expression of surprise from us on discovering some exceptionally inefficient drives in the power transmission of his mill: "I don't wonder at your surprise. I know that we paper men are the worst old

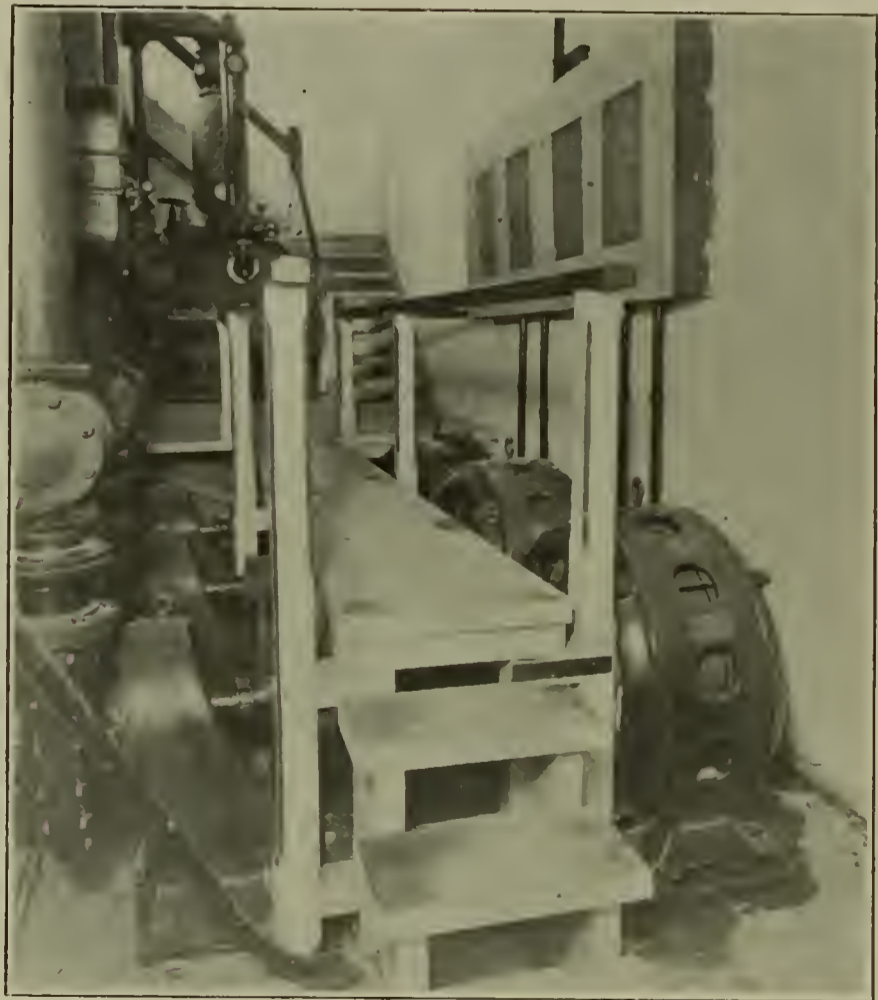

FIG. 2.—THREE 40-H.P. ALLIS-CHALMERS INDUCTION MOTORS DIRECT COUPLED TO WATER PUMPS.

has been that in the past we did so well, even under unfavorable conditions, that there was no apparent to the securing of low cost of production and high-grade output than the adoption of the electric system of

power transmission. This is a very broad statement, but it can be substantiated by a careful investigation of the results obtained from mills which are actually equipped with the electric system. Naturally, the first question which arises in the mind of the mill operator is wherein will the use of electricity as a motive power lead to lower cost of production and a higher grade output. The answer to this question is found in a number of primary effects resulting directly

shafts of driven machines with an average loss of from 20 to 25 per cent., from three to five per cent. of this being in the wiring and the balance in the generators and motors. Moreover, we reduce the loss to this low point regardless of the complexity of the system or the distance of transmission. Distance enters into consideration only in so far as it affects the size of the wire required to transmit a given quantity of power. We can make the losses in the wire as

help being impressed by the entire absence of the usual shafting and belting. The power-house, as it were, is brought directly to each machine through the medium of a small wire on the ceiling, which requires practically no space and is in no one's way.

*Greater Reliability.*—Where the operation of any particular machine or line shaft is dependent upon that of a number of other shafts, with many belts intermediate between this machine or shaft and the prime mover, there is always the liability of an entire shut-down, due to the failure of one of the intermediaries. In a paper mill this possibility is increased by reason of the fact that many of the belts are large and very heavy, causing a great strain to be put upon the shaft, hangers and pillow-blocks and resulting in throwing the shafting out of alignment and heating the journal boxes, to say nothing of breaking the belts themselves. It should not be forgotten, either, that a shaft out of alignment rapidly increases the friction losses.

With the electric system there are no intermediaries. Each motor, with the machine or shaft which it drives, is really a separate unit, and, as the failure of the wiring is a most unusual occurrence, is dependent on nothing but the operation of the prime mover itself. In regard to the reliability of electric generators and motors, the best evidence of the high esteem in which they are universally held is found in the great and con-



FIG. 3.—FIVE 10-H.P. ALLIS-CHALMERS INDUCTION MOTORS BACK-GEARED TO WET MACHINES.

from the use of the motor drive, each one of which bears its part in securing the final result above mentioned. These primary effects may be classified as follows:

(1) Reduction of transmission losses; (2) greater reliability; (3) greater elasticity; (4) reduced cost of maintenance; (5) steady speed throughout the mill; (6) ideal conditions for the paper machine; (7) saving in space; (8) decreased chance of injury to employees; (9) greater cleanliness.

*Production of Transmission Losses.*—In every mill with old-style equipment the quantity of belting, pulley, hangers and shafting is something appalling, and the losses of transmission through this complex system are very large. Actual tests show that these losses, which are usually termed friction losses, vary from 40 to 60 per cent. of the power delivered at the engine or water-wheel shaft; 50 per cent. being a very fair average. This figure, of course, does not apply to the grinders or the beater shaft when driven direct, as is usually the case. The more complex the system of shafting and bolting becomes, and the greater the distance of transmission from the source of power, the more rapidly does the percentage of friction loss increase. In comparison with this we are able, with the electric system, to transmit power from the shaft of the prime mover to the

low or as high as we please by increasing or decreasing, respectively, the size of the wire. In practice, five per cent. is considered a commercial allowance for installations of this character.

It is evident from the above that in the power transmission alone a saving of from 15 to 40 per cent., depending on the conditions to be met with in each individual case, can be effected by the use of the electric system. A modern two-machine mill, with the prevailing tendency toward large size machines, will require outside of the grinders, from 1500 to 2000 h.p. Assuming the minimum saving of 15 per cent. on this, we shall have a net gain of from 225 to 300 h.p., a very considerable sum when reduced to the basis of dollars and cents. In a steam-driven mill this saving would be represented by the decreased consumption of fuel; in a mill where water is the prevailing power the saving will appear in the additional volume of water available for grinding pulp, or for extensions; and in these days pulp is a very valuable asset, which can always be marketed to mills that are unfortunate enough not to possess sufficient water-power to grind their own pulp.

The equipment of the new mill of the Watab Pulp & Paper Co., near St. Cloud, Minn., affords a striking example of minimized transmission losses. A visitor to this mill cannot



FIG. 4.—5-H.P. ALLIS-CHALMERS INDUCTION MOTOR BACK-GEARED, BELTED TO SAVE-ALL.

stantly increasing number of factories in all lines of industry which are operating under the electric system. The motor troubles, of which we occasionally hear, are in nearly every case directly traceable to poor engineering in laying out the installation or to negligence on the part of those employed to look after the electrical apparatus.

*Greater Elasticity.*—The term elasticity, as applied to an electric system of power transmission, is intended to

convey the idea of easy expansion and application to all of the many power problems encountered in the modern mill or factory. If the mill operator wishes to install new apparatus he does not have to stop to figure out how he is going to get power to the

it is better to direct couple to the water-wheel shafts (although there are some enthusiasts who favor driving these also by direct-connected motors). The equipment of the Watab Mill, previously referred to, is carried out along the lines recom-

upon them by very heavy or very tight belts; shafts thrown out of alignment by these same strains—in short, something continually happening to claim the repair man's time and try the patience of the operator as well as draw on his bank account.

Contrast the above with the situation in an electrically equipped mill where shafting is practically eliminated. The chief engineer and his assistant can easily take care of the electrical apparatus, for all they have to do is to see that the bearings of the motors and generators are properly lubricated, and, in case the equipment is of the direct-current type, to keep the commutators clean and the brushes properly adjusted. With alternating-current motors, which have no commutators, there is absolutely nothing to require attention but the bearings. Burn-outs in the windings of the motors are practically unheard of, but even if they should occur, the motor can be repaired in less time and with less expense than is required to restretch a broken belt or replace a melted-out journal. The services of at least one man and possibly two or three are saved outright and there is practically no expense for supplies, as none are required except for extensions after the installation is completed.

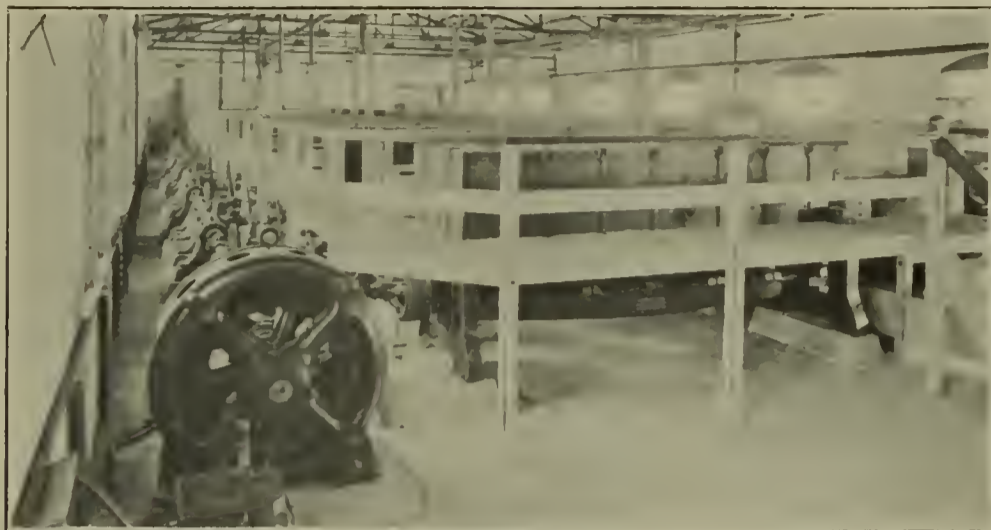

FIG. 5.—100-H.P. ALLIS-CHALMERS INDUCTION MOTOR DRIVING FLAT SCREENS IN WET MACHINE-ROOM.

new machines—he knows that all he has to do is to install a motor and run a wire to it. It does not matter whether the new apparatus is upstairs, downstairs, around the corner, or across the street from that already installed; it may be half a mile or more away, and still it is simply a case of a motor and some wire. Many times an entire new power plant is saved by this great elasticity.

Another phase of this same elastic system lies in our being able to distinguish between the different types of power service required throughout the mill and to treat each individual case on its merits and in the manner calculated to secure the highest efficiency of operation. We have constant speed motors for constant speed work, variable speed motors for variable speed work, elevator motors to drive the elevators and crane motors to operate the cranes. In the old system it was always a case of belting; but with the electric system we can either direct connect, gear or belt the motor to the driven machine, as may seem best. In general, for paper mills it is better to direct couple wherever this can be done without too great an investment in the motor by reason of the necessity for very slow speeds. The scheme usually followed, and which we recommend, is to direct connect the centrifugal pumps jordan, barkers, log saw and variable speed shaft of the paper machines; gear all duplex or triplex pumps, rotaries, calenders and wet machines; gear or belt the conveyors, rag dusters and cutters; and belt the beaters, elevators and all group drives. The grinders, in our opinion,

mended above, and the results have been most gratifying.

*Reduced Cost of Maintenance.*—Every one who has had experience with a complicated system of belting and shafting well knows what it means to keep it in running order.

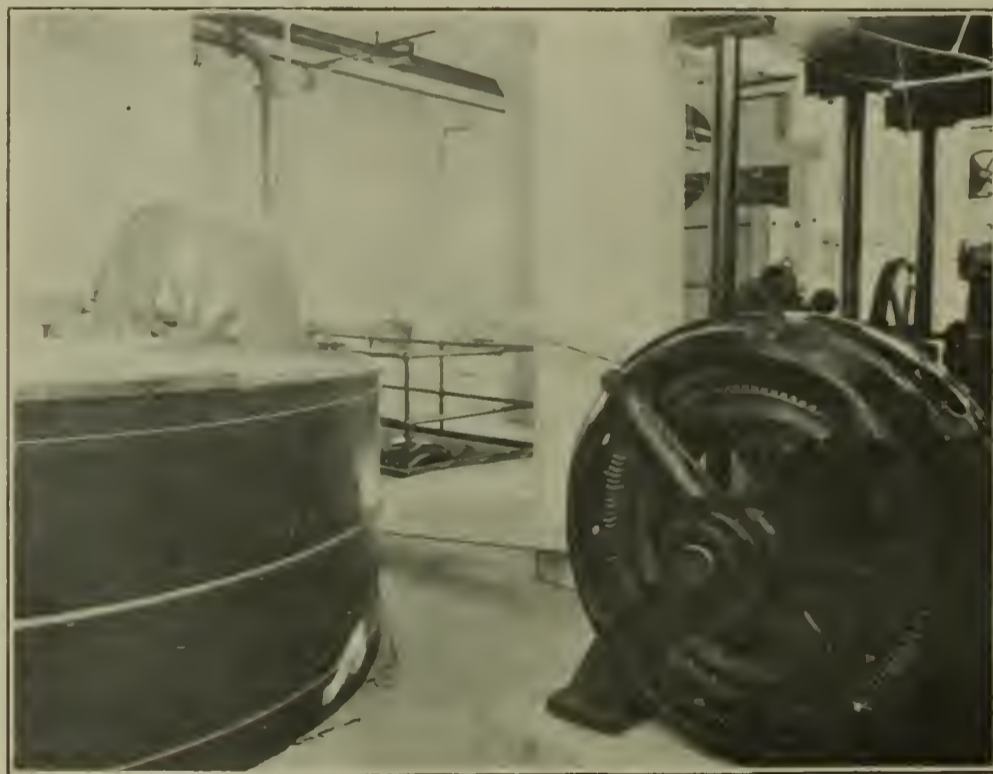

FIG. 6.—40-H.P. ALLIS-CHALMERS INDUCTION MOTOR BELTED TO BROKE-BEATER.

In the average paper mill much of the time of the mill-wright and his assistants is required for this work. A broken or stretched belt, a short belt that refuses to pull right until it is so tight that the journals heat, belts that run off because they have to round a corner, and belts that wear because they are twisted; journals that heat because of the great lateral strain put

*Steady Speed Throughout the Mill.*—One of the many drawbacks to the belt and shaft scheme of transmission lies in the constantly changing speed throughout the system. This change is not due so much to variation in the speed of the prime mover as it is to the effect of starting and stopping the various shafts or machines comprising the system. A

heavy load, thrown on or off in this way, reacts upon the apparatus nearest to it on the system, instead of upon the prime mover, as it should. With an electric installation, however, the effect of starting or stopping any motor is carried back to the switch-board, which is connected directly to the prime mover, and, as the prime mover is always provided with a governing device to control its speed, the other machines on the system are not interfered with. There are many machines where a continued variation in speed becomes a serious matter, and at all such times such changes impair the running efficiency of the mill and tend to lower the quantity and quality of the output.

*Ideal Conditions for the Paper Machine.*—The paper machine itself is the very heart of the mill, and the successful operation of the auxiliary apparatus is of no avail if there is trouble at this point. Nothing contributes so much to the ideal conditions for operation as a steady speed, which can at the same time be readily varied, and uniform temperature in the steam which is used for drying. Both of these requisites are possessed by the electric system. For reasons explained in the preceding section, we derive from the prime mover an almost absolutely constant speed. This speed, through the agency of the variable speed motor which has proven so satisfactory in service, can be varied at the will of the operator over a very wide range, and at the

high as three or even four to one. By the use of a controlling device and multiple voltage (although this slightly decreases the efficiency of operation), that ratio of speed change may be still further increased to six, eight or even 10 to one. One of the most

the motor is direct coupled. The speed can be varied over the entire range without a shutdown, which means that the machine tender can change from one grade of paper to another, no matter how great a difference, without stopping the ma-

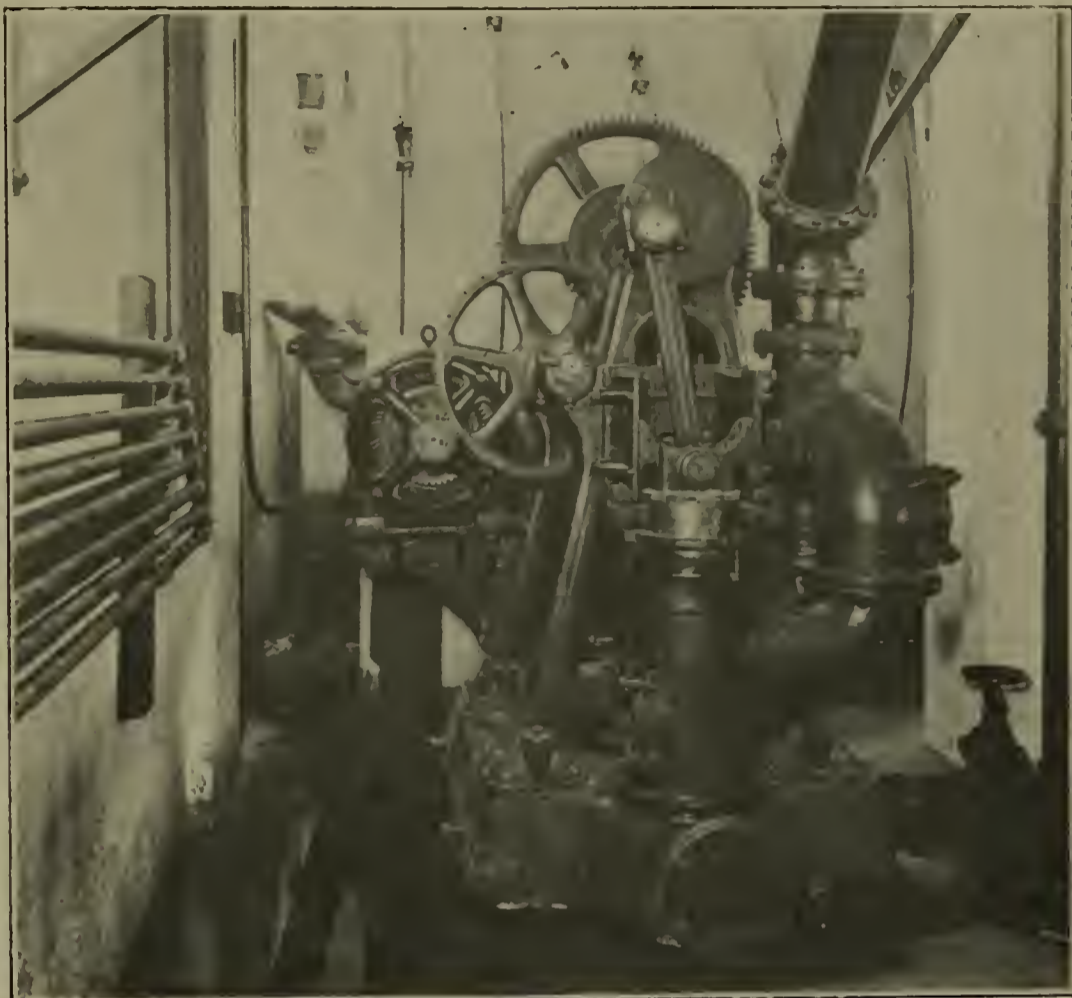

FIG. 8.—7½-H.P. ALLIS-CHALMERS INDUCTION MOTOR GEARED TO PAPER MACHINE PUMP.

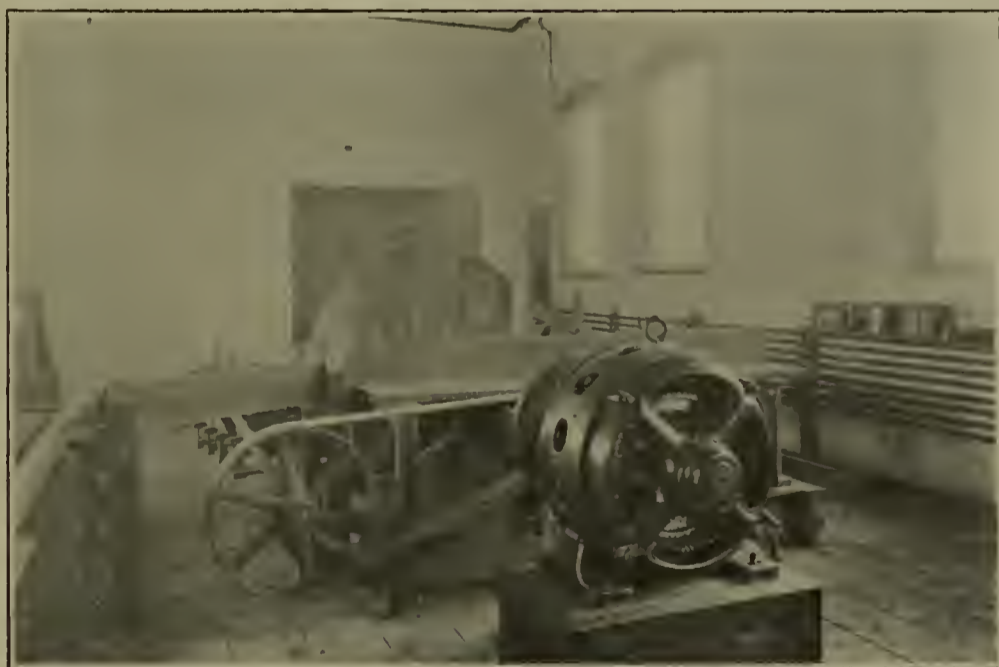

FIG. 7.—30-H.P. ALLIS-CHALMERS INDUCTION MOTOR DIRECT COUPLED TO LOG SAW; WOOD CONVEYORS DRIVEN BY MOTORS IN BASEMENT.

same time the motor maintains practically a constant efficiency. Variable speed motors on paper machines, in actual operation to-day, have a ratio of speed change of two to one under these constant conditions of efficiency, and it is entirely practicable to get as

important features of the speed change lies in the fact that the successive increments of the change are very small; each step on the controller means a change of only 1.5 to two revolutions on the motor, or on the variable speed shaft to which

chine. The difficulties of maintaining a constant speed, when the machine is driven from an engine operated under a varying steam pressure and varying load, are too well known to require more than mention. The clumsy and inefficient mechanical speed changers, step pulleys and cones are always a source of trouble and, compared with electric transmission are the makeshift of a past age.

The single objection raised by some manufacturers to the electric system is with regard to the economy of the drive on the paper machine itself. They contend that as long as it is necessary to use steam for drying it would be better to drive the machines by engines and use their exhaust rather than drive by motors and dry by live steam. In a consideration of this point we should divide the mills into two classes: First, those whose initial power is water, and second, those whose initial power is steam. We are certain that even the most ardent advocates of the use of steam engines and exhaust steam will admit the superiority of electric drive in the case of mills of the first class

where ample water power is available for all purposes, for there can be no questions that the generation of electric power from water is cheaper and more efficient than the generation of steam power from coal. The only argument, therefore, is with respect to mills of the second class, which must produce all or a part of their power from steam. Many such mills, partially steam driven, could be placed in the water-power list by the adoption of the electric system, the power thus saved being equivalent to that produced by steam. Admitting, for the sake of argument, that in mills of the second class it is more economical to use engines on the machines—which contention is open to dispute—

by water power, no engines whatever will be required; if by steam, the engines will be used solely to drive the electric generators in the powerhouse. In either case the drying will be done by live steam taken directly from the boilers, and brought down to the proper pressure through a reducing valve. By this method we are assured of a constant pressure, which means a uniform temperature in the dryers of the machine. There is, of course, no reason, in a steam-driven mill, why the exhaust from the engines driving the generators cannot be used for this purpose if desired, but if the drying is done with exhaust steam, it is almost out of the question to maintain a uniform temperature,

sult, a large floor space is available for the storage of stock, and for storage in such a manner as to afford ready access, not only to the stock itself, but also to adjacent machinery. No greater contrast between electrically-driven and shaft-driven mills can be found than is evidenced by photographs of their respective basements. It is no uncommon sight, in mills of the latter class, to encounter such a mass of waste, stock and machinery that it is almost impossible to get at either.

*Decreased Chance of Injury to Employees.*—The protection of the lives and limbs of his employees is, naturally, one of the first thoughts of a manufacturer, and yet hardly a day passes but that we read of some operative getting caught by a belt, pulley or shaft and either losing his life or being seriously injured. Such accidents it is almost impossible to prevent where a system of shafting is in use—the two evils are co-existent. There is also a sequel to accidents of this character in the shape of damage suits which, under the employers' liability laws existing to-day, frequently results in large losses to the owners of plants; in a recent case of this kind the plaintiff—a mill hand—received a verdict of \$15,000, which was confirmed by the Supreme Court.

*Greater Cleanliness.*—In a paper mill cleanliness is of paramount importance, and nothing contributes more to a high-grade product than clean stock to a clean mill, particularly a clean machine room. Belts, pulleys and shafting are potent conveyors and disseminators of dust, dirt, grease and filth of all kinds, and the only safeguard against these evils is to do away with pulleys and shafting, which can be accomplished only by substituting electric drive.

In the foregoing we have endeavored to present, as briefly as possible, some of the more important arguments in favor of the electric system of power transmission for paper mills. The true significance of the statements can only be appreciated by those who have adopted the system, and of this number we feel safe in saying that there is not one who will not substantiate what has been said. One of the most encouraging features of the situation, and one which augurs well for the future expansion of electrical equipment in paper mills, lies in the fact that many operators who originally were skeptical or openly opposed it are to-day loudest in sounding its praises.

As an illustration of what can be accomplished by the adoption of the system advocated in the preceding paragraphs, a brief description of the new mill of the Watab Pulp & Paper

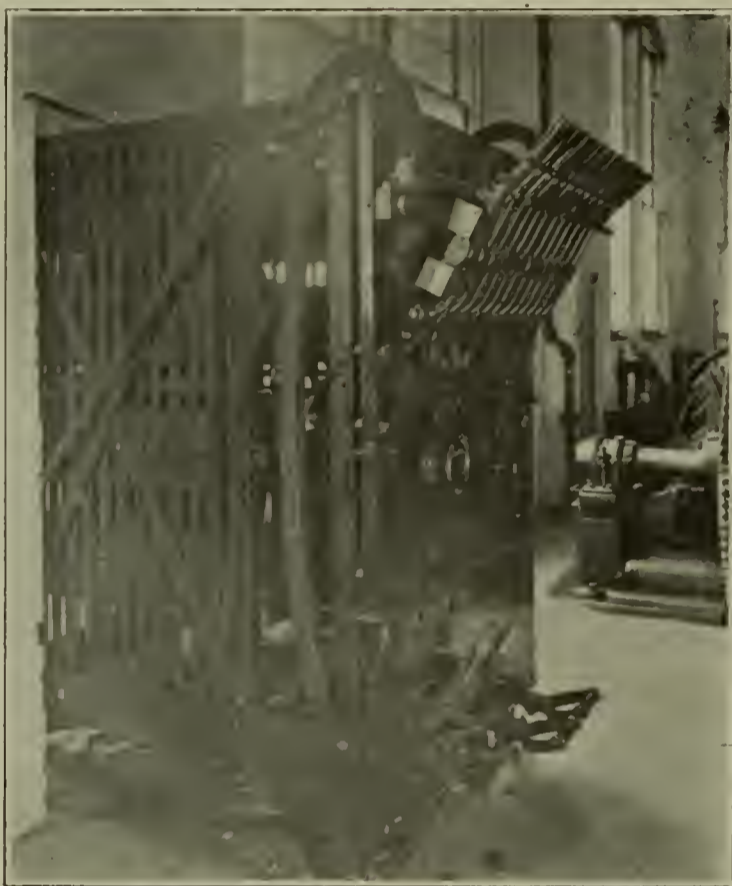

FIG. 9.—CUTLER-HAMMER CONTROLLER FOR 250-H.P. ALLIS-CHALMERS VARIABLE SPEED MOTOR LOCATED ON PAPER MACHINE FLOOR. THE CONTROLLER GIVES TEN SPEED CHANGES.

the many advantages of the electric drive, as described herein, are more than efficient to outweigh the possible saving in fuel. Moreover, we see no reason why the exhaust from the main engines driving the electric generators could not be used for drying if desired; and if this is done the question of economy is wiped out entirely. Another contention which has been advanced by paper manufacturers who are using the electric drives on their machines and live steam for driving, is that the use of live steam permits of maintaining a constant temperature on the dryers, resulting in a uniform sheet of paper of high finish, a condition which cannot be as easily secured by exhaust steam on account of the varying pressure in the line. If the mill be driven

as the exhaust frequently drops to so low a temperature that it is practically water and of little value for drying. Admitting, for the sake of argument, that it is cheaper to dry with exhaust than with live steam—which fact is open to dispute—the advantages of the live steam outweigh any possible saving in the use of the exhaust.

*Saving in Space.*—Doing away with so much shafting, with its accompanying array of pulleys, belts, hangers and pillow-blocks, naturally relieves, to a great extent, the congestion which exists in the average mill. As the motors are mostly direct geared or coupled, very little space is required by them, thus permitting the placing of the various machines close together, and at the same time affording ready access to all. As the re-



Co. may be interesting. This mill is located on the Mississippi River, at Sartoll, Minn., a few miles above St. Cloud, and is one of the most modern and best equipped plants of its kind on the American continent.

The mill buildings are all of reinforced concrete and consist of a machine room and basement 72 by 230 ft., a beater room and basement 40 by 122 ft., wood room and basement 36 by 70 ft., boiler house 58 by 72 ft., pulp mill 32 by 152 ft., pump room 20 by 70 ft., and power-house 32 by 72 ft. The boiler room contains two Sterling water tube boilers, which

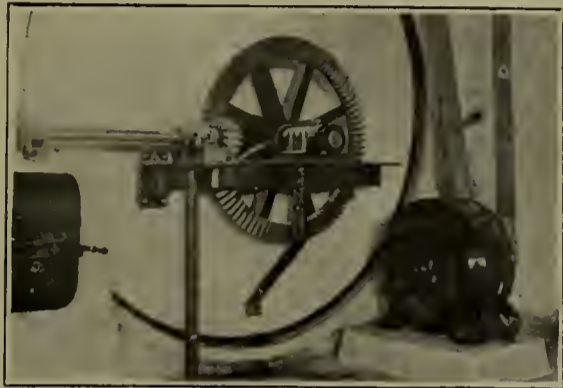

FIG. 10—30-H.P. ALLIS-CHALMERS INDUCTION MOTOR DRIVING MACHINE CHEST AGITATOR AND SCREENS.

furnish steam for heating the buildings and for drying the paper. All the power used in the mill, with the exception of that for the nine grinders, which are direct coupled to water-wheels, is generated in the power-house, which is located near the center of the river immediately adjoining the grinding room. A dam 600 ft. long was thrown straight across the river and affords a head of approximately 17 ft.; the power-house and grinding room form a part of the dam, and the remainder consists of gates and spillway of the ordinary crib construction—rock filled.

The generating equipment consists of three 600-kw., three-phase, 60-cycle, 480-volt, alternating-current, revolving field generators, each direct connected to a sextuplex water-wheel operating at a speed of 200 rev. per min. The exciting current for these generators is supplied from a 75-kw., 120-volt, direct-current generator, coupled to a single water-wheel, or from a motor-driven exciter of the same capacity. Two motor-generator sets, each consisting of a 250-kw., 240-volt, direct-current generator coupled to a 480-volt synchronous motor supply current to the variable speed motors in the machine room. The alternating system was adopted as being best suited to withstand the rigorous requirements of paper mill work and least liable to give trouble with motors when located in moist places, so common in every mill. The current is distributed through a 13

panel blue Vermont marble switch-board, arranged with wattmeters and ammeters so that an accurate log may be kept of the power required by each separate department. Thirteen feeder circuits carry current to 51 constant speed alternating-current induction motors and to eight variable speed direct-current motors.

The machine room contains two 154-in. Beloit machines. The variable speed shaft of each machine is driven by a 250-h.p., variable speed, direct-current motor coupled directly in the center of the shaft. This motor operates at a speed of from 270 to 540 rev. per min., corresponding to a paper speed of from 300 to 600 ft. per min. The entire variation is accomplished by means of resistance in the shunt field of the motor. The field rheostat controlling the speed of the motor has 138 steps, which means a change of approximately two feet per minute in paper speed for each step, which is surely a much finer variation than can be obtained through the medium of any mechanical speed changing device; it must be borne in mind, too, that the changing of speed is accomplished without any loss of time whatever, as the controller is located on the machine room floor—about midway of the drying rolls—and the movement of the con-

The only other direct-current motors in the mills are two of five-horse power capacity with a speed range of two to one, which drive special cutters located in the machine room basement.

The group at the wet end of each machine, in addition to the shake, consists of a save-all driven by five-horse power, back-geared induction motor, suction pump driven by 30-h.p., geared induction motor, fan pump with 40-h.p., direct-coupled motor, machine pump with 7½-h.p. geared motor and machine chest agitator and flat screens driven by 30-h.p. belted motor. To this group belong also the broke beater driven by 40-h.p. belted motor and the broke beater pump driven by 40-h.p., direct-coupled motor.

The beater room contains six beaters and two Majestic Jordan engines. The beaters are driven in pairs, one right and one left, by three 100-h.p. motors located in the basement. These motors have their shafts extended both ways with pulleys on either end; outboard bearings are also provided to insure rigidity and freedom from belt slippage. Belts connect the motors directly with the beater pulleys. The drive for the Jordans is one of the most noteworthy in the mill. Each Jordan is directly coupled to a 150-h.p. motor operating at 312 rev. per

SCHEDULE OF MOTORS IN WATAB MILL

Department	Number	Motors Horse Power	Type	Machine Driven
Wood Room.....	1	5	Induction.....	Log Haul
	1	10	"	Conveyor and Splitter
	1	10	"	Prepared Wood Conveyor
	1	30	"	Log Saw and Live Rolls
	6	7½	"	Barkers
	Boiler House.....	1	40	"
1		10	"	Coal Conveyor
2		50	"	Pulp Pumps
Pump Room.....	1	40	"	Decker Pumps
	1	40	"	Pressure Pump on Grinders
	1	7½	"	Back-off Pressure Pump on Grind'
	3	40	"	Water Pumps
Wet Machine Room..	1	5	"	Sliver Screen
	5	10	"	Wet Machines
	1	100	"	Flat Screens and Deckers
Machine Shop.....	1	10	"	Lathes, Planers, etc.
	2	350	Synchronous.....	Dir. Current Generators
Power-House.....	1	115	Induction.....	Dir. Current Excitor
	1	150	"	Jordan Engines
	3	100	"	Beaters
	3	7½	"	Stock Pumps
	2	15	"	Stock Chest Agitators
	2	250	Dir. Cur. Var. Speed.	Var. speed Shaft of Machine
	2	35	"	Rewinders
Machine Room.....	2	7½	"	Shakes
	2	30	Induction.....	Suction Pumps
	2	40	"	Fan Pump
	2	40	"	Broke Beaters
	2	40	"	Broke Beater Pumps
	2	7½	"	Machine Pumps
	2	30	"	Agitator and Screen
	2	5	"	Save-all
Finishing Room.....	2	5	Dir. Cur. Var. Speed.	Rewinders

troller handle is but the work of a second for the machine tender. The re-winder at the head of each machine is also driven by a variable speed of 30-h.p., direct-current motor having a speed range of two to one. Two 7½-h.p. motors of the same type, with 25 per cent. speed variation, operate the shakes of the two machines.

min. The base of the Jordan is extended to receive the motor, which is arranged to slide on rollers as the plug is moved in or out by means of the regulation hand wheel. In the beater room basement are located the stock pumps for supplying the Jordans, each driven by a 7½-h.p. geared motor and also the Jordan chest agi-

tators driven by two 15-h.p. belted motors. The controllers for starting and stopping all motors governing the supply of pulp to the beaters and Jordans are located on the beater room floor, so as to facilitate rapid handling of stock.

In the pump room are located the pumps controlling the water supply and those for handling the ground wood pulp. The entire water of the mill, outside of the boiler feed, is obtained through three six-inch centrifugal pumps, each direct connected to a 40-h.p. motor. An underwriter's pump is used for fire purposes only. Two centrifugal pumps for pumping pulp from the grinders to the flat screens in wet machine rooms are located in a pit beneath the pump room. Each of these is direct connected to a 50-h.p. motor. In this room are also the centrifugal Decker chest pump direct coupled to a 40-h.p. motor, the triplex pressure pump for grinders driven by a 40-h.p. geared motor, the triplex back-off pressure pump driven by a 7½-h.p. geared motor and the silver screen driven by a five-horse power back-geared motor.

The wet machine room contains five wet machines, two deckers and

12 flat screens. The wet machines are each driven by a 10-h.p. back-geared motor. The flat screens, which are located immediately back of the wet machines, are driven through friction clutches connected to a line shaft by means of a miter gear, this line shaft being direct coupled to a 100-h.p. motor. The deckers are driven by belt from the wet machine shaft. A machine shop adjacent to the wet machine room is driven by a 10-h.p. belted motor.

The wood room equipment consists of six barkers and a 60-in. log saw with the necessary conveyor. The logs used for making pulp are taken from the river to the saw by a log haul which is driven by a five-horse power back-geared motor. The saw and live rolls are direct coupled to a 30-h.p. motor, the coupling being of sufficient weight to act as a fly-wheel, and thus reduce the actual power required for sawing. The sawed wood is carried to the barkers by a conveyor driven by a 10-h.p. back-geared motor; this same motor also drives a splitter. The barkers are each driven by a 7½-h.p. direct-coupled motor, the iron base of barker being cast with a pedestal to receive the motor.

The prepared wood is carried to the grinding room by a conveyor driven by another 10-h.p. back-geared motor. A shaving fan driven by a 40-h.p. belted motor blows the chips from the barkers directly on to the boiler grates. What additional coal fuel is required is carried in hoppers above the boilers. A 10-h.p. back-geared motor drives a bucket elevator which fills the hoppers directly from the cars in which the coal is shipped.

The Watab mill has now been in continuous operation for nearly one year. It began making paper a few hours after current was first turned on, and has not been shut down since due to failure of equipment—a most unusual performance for a mill of this size. The complete electrical installation was furnished by the Allis-Chalmers Company, and the design and specifications were prepared by engineers of the Allis-Chalmers Company, acting in conjunction with the mill superintendent and Mr. Samuel Holmes, paper mill expert and engineer. The officers of this mill are justly proud of their property and are ready and willing at all times to answer inquiries from interested parties pertaining to the mill and its equipment.

#### The Westinghouse Electrically Heated Sad-Iron

In form the Westinghouse Electric iron differs only from an ordinary iron in its more symmetrical and attractive appearance, and in being provided with terminals and a flexible cord through which the current is transmitted. In operation it elevates ironing from hot drudgery to a comfortable and pleasant task. Its heating mechanism, which is entirely concealed, keeps the iron at the proper temperature at a minimum consumption of current. It consists of a flat insulated resistance strip clamped by hydraulic pressure between two flat iron plates, forming a solid heating element of high thermal conductivity, and having a large heat storage capacity.

The design of the element is such that the heat is evenly distributed over the entire bottom of the iron, the edges and point being practically at the same temperature as the middle of the bottom. A non-conducting element is used between the top of the iron and the heating unit. This construction results in the top of the iron being cooler than its face. The heating unit is hermetically sealed in its insulation and cannot, therefore, deteriorate any faster than the iron, as it is not subject to the oxidizing effects caused by contact with air.

The iron is extremely simple and

there is absolutely nothing to get out of order or to require renewal. Irons which have been in use continually for the past six years, without costing a cent for repairs, are in as good condition to-day as ever. In fact, the electrical construction is so simple and durable that there is no reason why it should not last as long as the iron itself.

The terminals are protected by a solid metal guard, and the cord leading from them is securely anchored by a clamp on the handle of the iron. A wire spring which surrounds the cord at this point prevents any sharp bends. A separable plug is provided by which the iron can be connected to any convenient lamp socket without twisting. A small spring attached to the cord takes up all slack and so keeps it from dragging on the clothes or getting in the way of the operator.

The polishing surface of the iron is of highly polished cast iron, found by experience to be the most satisfactory surface for the purpose. The upper portions of the iron have a burnished nickel-plate surface. The handle is of ebonized wood, heat-proof and unbreakable. A heat-proof stand, upon which the iron should be set when not in use, is provided with every iron.

The irons are made to suit all commercial lighting circuits, and can be used on either alternating or direct

current with equally satisfactory results.

#### The Electric Drive in a Hardware Factory

The popularity of the electric motor drive is due in no small part to the general satisfaction that has attended the use of squirrel cage induction motors. Simple and rugged in construction, reliable and efficient in operation, they are remarkably free from the operating difficulties that attend the use of the more sensitive commutator motor. Manufacturers, realizing these as well as the further advantages pertaining to the use of the electric motor drive as a whole, now specify electric motors for power purposes when contemplating the erection of a new plant or the enlargement of the old.

A notable example of the application of the induction motor drive to the solving of power problems in a modern manufacturing establishment is found in the factory of the O. M. Edwards Company, of Syracuse, N. Y. This company is an extensive manufacturer of hardware specialties used in both the steam and electric railroad trade, such as window and extension platform trap-door fixtures, steel window sash, molding, etc. Formerly, the company purchased power from the Syracuse Lighting Co., using 500-volt direct-current motors for

(Continued on page 10 of ad. section).

# THE ELECTRICAL AGE

Volume XXXIX. Number 3.  
\$1.00 a year; 15 cents a copy

New York, March, 1908

The Electrical Age Co.  
New York and London

ESTABLISHED 1883

Published monthly by The Electrical Age Co., 45 E. 42d Street, New York.

J. H. SMITH, Pres. C. A. HOPE, Sec. and Treas.

JOHN HAYS SMITH, Editor.

C. G. HEQUEMBOURG, Adv. Mgr.

Telephone No. 6438 33th. Private branch exchange connecting all departments.

Cable Address—Revolvab, New York.

## SUBSCRIPTION RATES

United States and Mexico, \$1.00; Canada, \$1.50. To Other Countries, \$2.50

## NOTICE TO ADVERTISERS

Insertion of new advertisements or changes of copy cannot be guaranteed for the following issue if received later than the 15th of each month.

## LONDON OFFICES

Business and Editorial Departments, 33 Bedford Street  
Strand, W. C.

London Telephone, Post Office, 3807 Central. Private branch exchange. London Cable  
Address—Revolvab, London.

All remittances to London Office should be crossed London and County Banking Company.

## BRANCH OFFICES AND AGENCIES

Subscriptions may be sent to the following branch offices or agencies, where they will receive the same careful attention as at the home office in New York:

124, Queen St., Melbourne

359, George St., Sydney

61, Main St., Yokohama

23, Esplanada Rd., Bombay

33, Loop St., Cape Town

Unter den Linden, 5, Berlin

Nevsky Prospect, St. Petersburg

31, bis rue de Fauburg Montmartre, Paris

General Agents for United States and Canada: The American News Company

## Illuminating Engineering

"Illuminating engineering is not a matter of light distribution—it is a matter of suitable lighting, and the conditions determining what is suitable are just as different as any two designs that are different," was the statement of Bassett Jones, Jr., before the Illuminating Engineers' Society on December 12, 1907.

We are inclined to believe that Bassett Jones, Jr., is right. The matter is very plain. Architects have always fixed the lighting of the edifices they design and always will. Lighting is only a detail, but it is a very important one for all that. The trouble about it arises out of the confusion of new illuminants.

We are quite prepared to admit that it would absorb the entire energies of an individual mind to post itself on the changeful types and the evolution of particular forms of electrical lighting. Assuredly, there is room at the present for expert knowledge in the matter, but is it likely to continue longer than the settlement of manufacturer's claims for illuminants?

Owing to the rapid spread of electricity as an illuminant, and the desire of large commercial interests to further that object, there has been created almost by a fiat a branch of engineering known as illuminating engineering. We are of the opinion that it will not long maintain a separate existence, and that its name will not endure as a distinct craft. While undoubtedly the introduction of a variety of electrical illuminants with varying degrees of merit and varying limitations, has caused much concern to architects, and unquestionably created a demand for a man who can definitely regulate the light distribution of units, there is no warrant to believe that the so-called profession of illuminating engineering will have

a long tenure or prove attractive as a life work.

The architects themselves are beginning to understand. They are now training men to study the technical limits of the lights which they use. In a few months an ordinarily trained mind can familiarize itself with the laws governing the distribution of light, and the facts about the quality of commercial illuminants.

When it is clearly understood that knowledge of this sort is a desirable part of the equipment of an architect, it is only a question of time until schools of architecture get definite courses on the subject and text-books contain adequate instruction on the use of illuminants. While we realize that prophecy is a dangerous art, we nevertheless predict that after a few years the matter of illumination will not be a problem for electrical experts at all, but a matter for the regulation of architects.

By years of training the architect becomes intuitively familiar with the use of colors in decoration and with the esthetic distribution of lighting fixtures. It is impossible that an engineer will ever get this intuitive knowledge, and so it is that urging engineers to "study" this sort of thing is like carrying coals to Newcastle.

New York City probably contains more engineering attempts at "placing light" than any other spot in the country; many of them are creditable, some are distinctively wretched. No more miserable work can be cited than the illumination of the United Engineering Society's Building. In its library on the thirteenth floor one has a feeling that he is groping in the dark among books and stacks, and outlines of tantalizingly shadowy form, and he emerges into the corridor straining his eyes to see. It is a welcome relief to leave it behind.

## Non-Synchronous Generators

The paper on non-synchronous generators by Mr. W. L. Waters, read before the American Institute of Electrical Engineers, at the February meeting, is very suggestive and should be carefully considered by all central station men. Mr. Waters proposes the use of the well-known polyphase induction motor as a generator. When such a motor is connected to a line on which electromotive force is already maintained and an engine drives its rotating part, it will revolve slightly faster than synchronism and the electromotive force generated by the rotation will be somewhat greater than that of the line, and current will be supplied by the motor.

This type of generator has several characteristics which are radically different from the usual or synchronous type. Its salient characteristics are as follows:

It does not have to be synchronous at all, but may be thrown on the line at any time, provided its speed is approximately right. This fact results from the machine having no field of its own. It takes its magnetizing current from the line just as when used as a motor. For this reason there must be voltage on the line before the motor, or rather the generator, can be thrown on, or it will generate no current, since it will then have no magnetism in the iron.

When a line is short-circuited it will not add current to the short-circuit current, since the killing of the line voltage kills the magnetism of the generator. It will not, therefore, add to the short-circuit current, which is so destructive in many cases—this is rather an important consideration.

The magnetizing current which is taken from the line by the non-synchronous generator is, of course, a lagging current. Furthermore, the

nature of this generator is such that it can supply current only in phase with the line voltage.

That the non-synchronous generator cannot supply lagging current is most important, and is one of the characteristics of this particular type. When any lagging load is to be carried on a system in which this sort of generator is used, all of the lagging component must be carried by the supply that maintains the line voltage initially for magnetizing the non-synchronous generator. It is the greatest disadvantage of the new type of generator and is serious, for generators of the usual synchronous type must then operate under unfavorable conditions at a relatively low power-factor.

The new type of generator is especially useful with steam turbines, for the short-circuited secondary may be made the rotating part, and any convenient mechanical construction used for withstanding the centrifugal strains, since no insulation need be here maintained. Collector rings are also avoided, which is of some importance in turbo-generators.

Mr. Waters states that these machines when used as turbo-generators will often have a higher efficiency than the old type, and also a very high power-factor. Though he makes no actual statement as to cost, he leaves the impression that they will not be at a disadvantage, at least in many places.

In an innovation as radical as this it is impossible to assign the actual field of usefulness in advance of trial and experience and the detailed laying out of particular plants, but on the other hand the advantage of having a generator that does not have to be synchronized, which will not give enormous currents on short circuit and which is so mechanically satisfactory for turbine work should cause engineers to give it very careful thought.

Mr. Waters suggests a number of uses for the machine and outlines a number of ways in which its great weakness, the need of an additional generator to excite and to carry the lagging load may be overcome. His argument is not in all cases convincing, especially where he advocates obtaining of the exciting current from the substation rotary converters.

Large central stations already operating and needing to add a large amount of additional power can well afford to consider whether a non-synchronous turbo-generator unit would not be the most satisfactory type. Under these conditions the lagging current could readily be carried by the old apparatus and a large block of

power added in the non-synchronous unit when desired. The great simplicity of this type, the elimination of synchronizing and the great overload capacity are important considerations.

It is worth noting that the new type of generator has a very strong tendency to smooth out all harmonics from the line wave, which is a material advantage, though one easily overrated.

A rather ingenious use of the new machine is cited by Mr. Waters in a plant delivering heavy low voltage direct current at some distance from the source of power. A non-synchronous generator drives a rotary converter at the end of the line, and all of the exciting current is supplied by the rotary converter, which must be first started. No synchronizing is required. This plant has operated very satisfactorily.

#### Standard Handbook for Electrical Engineers

Another handbook has come, will live its short life and will then be put on the shelf where the out-of-date books are kept, and all this will happen before its fine red cover shows signs of age. Mr. Otis Allen Kenyon deserves much credit for the painstaking way in which he has collected an immense amount of data and presented it in a rational and consecutive order, but it is to be regretted that he did not use his ample knowledge of the English language to present it in a more condensed form better available for reference.

While the typographical work is excellent, except for its small size, the plates are anything but first class. The occasional use of heavy type to catch the eye is excellent and is carried out consistently.

There is one fault which has been handed down like an heirloom from handbook to handbook which this book suffers from more than any that has gone before. It tries to tell you all about machine design—and fails. Machine design is the work of experts employed by manufacturers; they are supposed to know all that has been published on their subject and in addition know many trade secrets and tricks which, as a rule, only leak out of the factories when they are obsolescent. Then after going the rounds of the engineering societies and technical papers, they find their way into the handbook compilers' file and in due course of years appear in the handbook. Authors should learn from the old story of Atlanta not to lose the race by stopping to pick up the discarded golden apples. The first 65 pages of Section 7 on Electric Generators could, with advantage, be reduced to five pages. The re-

mainder of the section is comprehensive and clear, but the material is spread out rather thin. Sections 6 and 8 are also attempts to tell machine designers how to design machines (for who else could use the information?); but in the interest of our electrical industries we hope that the book is not needed for that purpose.

Section 11, on Transmission and Distribution, is one of the most important by reason of the fact that most of the matter treated therein is not in the hands of experts continuously engaged on the work, and is therefore a section to be often referred to by those who have grown rusty. It is unfortunate that this section is very badly arranged for reference and contains serious errors.

Referring to page 699, No. 213, there is a list of wire gauges, the "chief ones" only being mentioned. The B. & S. and B. W. G. are not among these!

At page 704, No. 237, the reader is recommended to cover a copper ground plate with *coke*. It is perfectly well known that a copper plate under such conditions will last for a few months only on account of the action of the sulphur contained in the coke.

Page 706, No. 246 gives the cost of stringing railway feeders from \$30 to \$60 per mile. The upper limit is very low and should, in fact, be more than doubled.

Referring to page 637, No. 26, the following statement occurs in a calculation:

$$\text{Impedance per wire} = \frac{\text{Line drop per wire}}{\text{Current per wire}} = \frac{2500}{235}$$

where 235 is the current and 2500 is defined as half the difference between transmitted and received voltages. The impedance is most emphatically *not* the ratio of half the difference between transmitted and received voltages to the current. It is the ratio of the potential drop in the line to the current, quite a different matter if the line power-factor differs from the load power-factor.

A technical error of this character carried through numerous examples covering several pages is apt to make one suspicious of the whole work, a feeling somewhat intensified when page 907 in the section on Electric Traction is reached, and the table entitled "Labor" shows a total of \$903.75 at the foot of a column which adds up to \$488.75.

Although the section on Traction is carelessly and incoherently written, it contains a wealth of data for the patient man who has time to look for it and separate it from the catalog stuff with which it is surrounded.

Telephony and telegraphy are not treated at great length, and one wonders why they are treated at all, being foreign to the rest of the book, which really deals with power engineering.

Section 19 is mostly taken from annual publications.

One of the most extraordinary collections of errors is that to be found concentrated on page 895 in the table on Third Rail Data.

While nobody thinks the B. R. T. Co. has their rail installed to within one-quarter inch, their official third rail gauge is  $20\frac{1}{2}$  in. from center of third rail to center of track rail, which is equivalent to  $21\frac{3}{4}$  in. from the gauge line of the track rail. Under the circumstances, the "Standard" may perhaps be forgiven for stating 22 in. instead of  $21\frac{3}{4}$ . More serious is the error in the third rail gauge of the Interborough, given as 22 in. instead of 26 in., as correctly given in the New York Electrical Handbook, p. 296, McGraw Pub. Co., and in *Street Railway Journal*, March 4, 1905, p. 427. The height of third rail surface is given in the "Standard" as  $4\frac{1}{2}$  in., while both of these references correctly agree that the proper value is four inches. The gauge for the Long Island R. R. is given as  $27\frac{1}{2}$  in., and should be 27 in., as stated in the *Street Railway Journal*, p. 832, vol. xxvi No. 19. The gauge for the West Short R. R. is given as  $28\frac{1}{4}$  in., and should be 32 in., according to the *Street Railway Journal*, vol. xxix No. 23, p. 1004. Again the gauge of West Jersey & Seashore, which ought now to be called the Camden & Atlantic City Ry., is given as  $27\frac{1}{2}$  in., while the authority of the *Street Railway Journal*, vol. xvii No. 19, p. 938, is in favor of 26 in. The Philadelphia & Western is said to have its third rail face six inches above the top of track rail. The *Street Railway Journal*, vol. xxix No. 24, p. 1055, shows that it is  $3\frac{5}{8}$  in.

We have not had sufficient time to check all figures, but having found seven errors in checking about a dozen cases, it would seem the part of wisdom to use this table with caution.

It is an excellent idea to present a composite clearance diagram, but it would have been better if the clearance diagrams of the New York Central and Pennsylvania Railroads had been consulted in its preparation. As it stands, the height is about nine inches shy and the width about four inches shy. Mr. Armstrong's composite diagram will fit loosely into those of the New York Central or Pennsylvania Railroads.

On page 189 is an alleged quotation from THE ELECTRICAL AGE, of April,

1907, relative to rubber insulation. The minimum desirable insulation resistance is quoted as 177 by  $10^7$  megohms per cm.<sup>3</sup> Reference to the AGE of that date shows the original figure to be 750 by  $10^6$  megohms per inch cube. This reduced to cm.<sup>3</sup> is 190 by  $10^7$ , not 177 by  $10^7$ , so that here is plainly a culpable error of calculation.

#### House Bill No. 10457

The acquisition of national forests in the Southern Appalachian Mountains and in the White Mountains is provided for in House Bill No. 10457, now before the House of Representatives for consideration. There is considerable opposition to the bill, rising chiefly from two sources: timber interests and the political constituents of the mountainous sections covered by the bill. The enforcement of forestry regulations by the Government would enhance the cost of timbering and require the education of lumbermen; this were difficult, hence opposition from this source. The mountainous poor have always been accustomed to use the forests as they pleased, and Government supervision means a curtailment of what has been regarded as the natural liberty of this class of people. In many sections of the South the whites living along the fringes of timber land are a considerable factor; hence another source of opposition to this bill. Nevertheless, it remains plainly to be seen that steps must be taken to protect our forests from further destruction; a comparative timber famine is even now upon us.

The interest of engineers and invested capital in water-power projects lies in the preservation of stream flow in the rivers, streams and creeks which are actually or potentially valuable.

The power of the soil to equalize the flow of water forming upon it is well known, and the protection of soil at the water sheds can be attained only by proper forest regulations. The soil of forest land is not usually deep, and is rarely over a few inches in depth on sloping land.

The soil consists of two parts more or less intimately mixed, the soil proper, formed by decomposition by the elements of underlying rocks, and the humus, or decayed vegetable matter formed by the imperfect oxidation of woody material.

Soil is worn away or denuded from the rock by the continual washing of rain driven at usually high wind velocities; the trees themselves break the cutting power of the rain and the moisture drops upon the soil, being absorbed by the spongy humus, from which it is gradually released. The presence of the trees serves another

purpose, viz.: the prevention of the evaporation of the water contained in the humus and thus further tends to prolong the flow of water from the soil. We must emphatically dissent from the opinion of an esteemed contemporary, which states that "even the greediest timber hogs could not cut on watersheds of most streams fast enough to permanently damage by the mere removal of trees." What the author of this statement really intends to say is that the proper removal of trees, even to the point of barrenness, would not materially damage the humus, and that with the preservation of the humus the growth of second timber would begin.

The latter process is frequently retarded and even completely destroyed by the entire destruction of the humus. Tangles of brush remaining after the trimming of trees quickly dry out and are often annoying in the clearing of the forests. Careless lumbermen remove this cutting debris by fire, and as the burning continues for days and is frequently little watched, it as often spreads to virgin forest timber. As a result of the fire we have imperfect combustion at the base of the flame-swept area and the reduction of vegetable matter to carbon, the process extending wholly through the humus of the soil and completely destroying its fertility. The process is very like that under which vegetable charcoal is manufactured, but it takes place on a larger scale. With the complete destruction of the soil, there is a checking, if not an actual cessation, of the process of regrowth.

Speaking of this condition in 1896, the late Professor N. S. Shaler, of Harvard University, the foremost geologist of this country, said: "South of Pennsylvania there is, according to my reckoning based on observation in every State in that upland country, an aggregate area of not less than 3000 square miles where the soil has been destroyed by the complete removal of the woods and the consequent passage of the earthy matter to the lowlands and to the sea. At the rate at which this process is now going on, the loss in arable and forestable land may fairly be reckoned at not less than 100 sq. miles per annum. In other words, we are each year losing to the uses of man, through unnecessary destruction, a productive capacity which may be estimated as sufficient to sustain a population of a thousand people. This rate has not only been kept up, it has been greatly accelerated. Faster than was considered possible 11 years ago, these regions, through injudicious cutting, fires, clearing and general misappropriation, are moving toward a forestless, soilless condition."

# The Central Station Distributing System Pressure Regulation

H. B. GEAR and P. F. WILLIAM

Commonwealth Edison Co., Chicago

THE inherent properties of the incandescent lamp which make it highly sensitive to variations in pressure necessitate refinements of regulation in electric lighting work which are not required in purely power or traction enterprises. As the excellence of a central-station's lighting service is determined very largely by the care and attention given to pressure regulation, much thought has been given to this subject by engineers from the earliest days of the industry.

In general, the regulation of pressure is accomplished by variation of bus voltage and by controlling the pressure on individual feeders by means of feeder regulators.

In direct-current networks uniform pressure is maintained on the mains by varying the bus pressure as the load changes, and by the fact that the regulation of pressure is, to some extent, automatic. When a heavy load is thrown on at any point in a network the pressure near that point is reduced, causing current to flow from all adjacent feeders toward the low point in proportion to the capacity of the mains in the vicinity of the load. The heavy load is thus carried in part by all the

lower pressure at remoter points. In the earlier development of networks it was customary to insert resistances in the feeders to prevent the pressure from running too high and thus robbing the longer feeders of a part of their load. In some cases this is unavoidable in modern practice, but the loss of energy in the feeder resistance is a considerable item, and the space required for their installation is usually prohibitive where feeder loads are heavy.

It is, therefore, found desirable to provide two or three separate bus bars, and arrange the switchboard so that the shorter feeders can be carried on one bus, those of medium length on

plicable to stations and substations having several units.

The operation of several busses is necessary only during the hours of heavy load, since the difference between loss of potential on the longer and shorter feeders is not so great during the hours of light load, and all feeders can be carried from one bus.

It is also possible to prevent pressure from running too high during the light-load period by opening a part of the feeders running to a given section, thus increasing the drop to the ends of the remaining feeders.

It is necessary in some cases with very long feeders to install a motor-driven generator called a "booster" in series with the feeder to hold its pres-

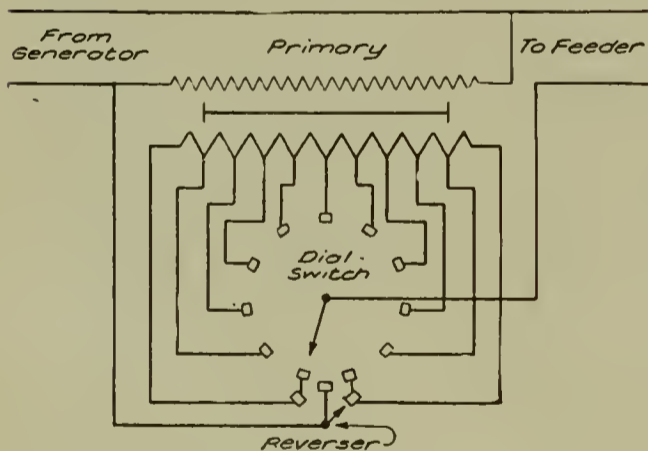

FIG. 1.

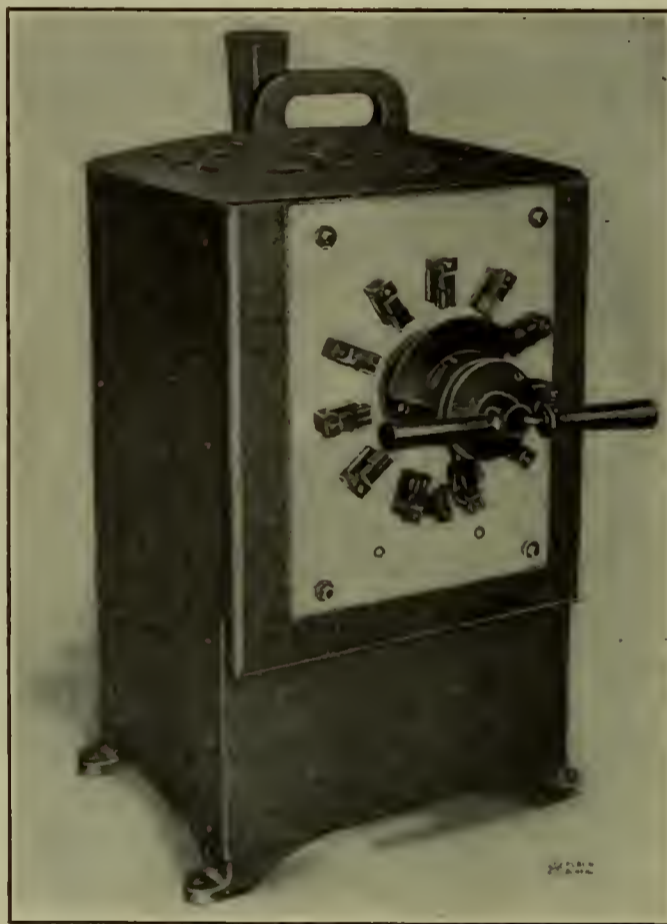

FIG. 2.

feeders nearest the low point, and this tends to prevent the pressure from falling as low as it otherwise would. On the other hand, the adjacent feeders being given more load, the pressure at their ends is lowered and the system tends thus to automatically equalize the pressure throughout.

The different lengths and conductivities of the longer and shorter feeders tend to produce higher pressure on the network near the station and

another bus and the longest on a third bus. Each bus is supplied by generators, rotary converters, or batteries, which can be independently regulated and each zone may, therefore, be carried at a pressure suited to the drop on its feeders without the use of feeder resistances. This arrangement, of course, requires a sufficient number of sources of supply of the proper capacity to carry the loads on the several busses, and is, therefore, only ap-

sure up. Such boosters are usually overcompounded to automatically maintain constant pressure at the feeder end at all loads. Where storage batteries equipped with end-cell switches are available it is sometimes feasible to put such feeders on the battery through a separate bus and thus avoid the use of a booster. The use of a booster is not to be recommended on long feeders until the cost of feeder copper required to produce equivalent

results considerably exceeds the cost of the booster equipment.

It is usual in low-tension networks to run pressure wires from the principal feeder ends back to the station, where they are connected to a multiple point switch in such a way that a voltmeter may be connected to the pressure wires of any feeder, and the pressure at any point in the network may thus readily be known at any time.

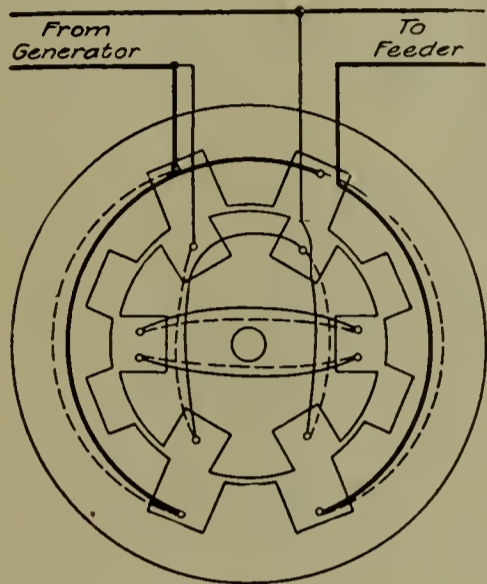

FIG. 3.

In operating the system a feeder which represents the average condition in any zone is selected as a "standard feeder." The pressure wires of this feeder are run to a separate voltmeter, which is used for regulating the bus which supplies the zone. The operator manipulates the field rheostats of the machines which are operating the bus, as may be necessary to hold the pressure as indicated by the voltmeter on the standard feeder constant.

A similar standard feeder is required for each bus, and in large systems a second standard is sometimes selected for use in case of emergency. In stations where a storage battery auxiliary is provided it is usual to adjust the battery pressure to that of the bus and to connect them in parallel. This permits the battery to "float" on the bus and to automatically charge and discharge as the pressure rises above, or falls below, the normal. The effect of this is to steady the bus pressure greatly and to maintain it in case of interruption of the power supply, provided the load does not exceed the limit of battery capacity when the interruption occurs.

In alternating-current systems the problem of pressure regulation is solved in quite a different way. Individual feeder regulators, which waste but little energy, permit the economical operation of all feeders on one bus, if it is desired. In low-tension networks the conditions are very

similar to those found in a direct-current network, but the problem is much more easily met because of the availability of feeder regulators. These regulators are also found useful in relieving overloaded feeders when the mains interconnecting them are of sufficient capacity to permit it. When a feeder becomes overloaded the regulators on adjacent feeders may be used to raise these feeder-end pressures, and this causes these feeders to take part of the overloaded feeder's load. Where the feeders are low tension, as well as the mains, and are installed underground, pressure wires may be embodied in the feeder cables, as is customary in direct-current distribution, at a small expense. If the lines are overhead, or the construction is such that separately insulated pressure wires are required, it is usually less expensive to utilize line-drop compensators instead.

In areas in which the load is so scattered that the distribution is effected chiefly by means of primary mains, it is usually found desirable not to interconnect adjacent feeders. This requires that each feeder be independently regulated to deliver the proper pressure at its terminus and feeder regulators are, therefore, very essential to a system having a number of feeders of different lengths and sizes. The design of an efficient and practical form of feeder regulator is fortunately not difficult, and there are two types in general use in America. Stillwell at an early date devised a transformer with a secondary winding tapped at equi-distant points, the taps being brought out to a dial switch. By the motion of this dial switch handle, more or less of the secondary winding could be thrown in series with the feeder, thus raising or lowering the pressure. A reversing switch was also provided by which the pressure of the regulating transformer could be opposed to the bus pressure, if desired. This type is illustrated in Figs. 1 and 2.

Another type of regulator which was developed somewhat later is known as the "induction" type, and is illustrated in Figs. 3 and 4.

In this regulator the variable voltage of the secondary is secured by turning the movable core on which the secondary is wound to different positions, thus linking more or less of the magnetic flux. If turned more than 180 degrees the secondary voltage is reversible through its full range.

This type is inferior in efficiency and power factor to the Stillwell type, owing to the presence of an air gap in the magnetic circuit, but its freedom from sliding contacts renders it more suitable for use in cases where remote or automatic control is em-

ployed. Remote control of regulators must be resorted to in situations where space is not available in the immediate vicinity of the switchboard, but may be had in a basement or on a gallery where it could not be utilized for other purposes so advantageously. Fig. 5 illustrates a typical equipment of this class, connections for which are shown in Fig. 6. An induction regulator is actuated by a small three-phase motor mounted on the regulator frame. A reversing switch, which is usually located on the feeder panel, enables the operator to move the regulator in either direction, thus raising or lowering the pressure. A limit switch is provided for the purpose of cutting the motor out when the regulator has been brought around to the position of maximum boost or choke. Hand control is also provided for use in emergency.

Automatic feeder regulation has been attempted to a limited extent in conjunction with the use of motor-operated regulators. In the earlier

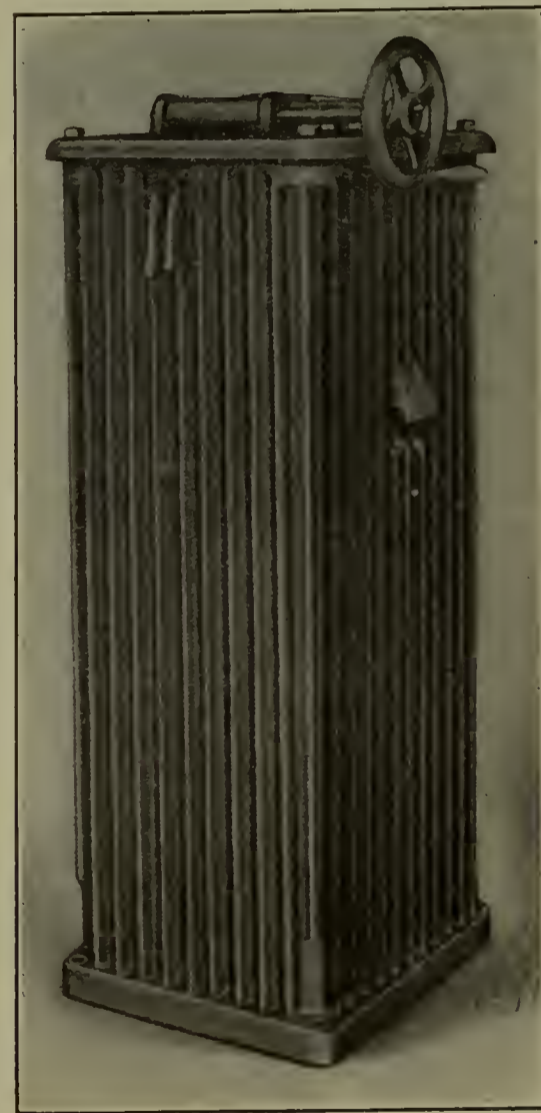

FIG. 4.

forms, power was supplied by a motor-driven line shaft, from which a belt supplied power to each regulator pulley. The regulators were provided with direct-current magnetic clutches operated by balanced relays, which caused the clutches to engage the dial switch of the regulator and so raise or lower the pressure.

The adaptability of this arrangement was limited by the use of direct current, which is often not available in alternating-current stations. The use of a line shaft was also impossible in

ing. A change in the current passing over the feeder causes the plunger to move and closes one of the voltmeter contacts. This operates the relay

troublesome, and the added expense of the automatic equipment for each feeder makes it preferable in most cases to provide automatic control of

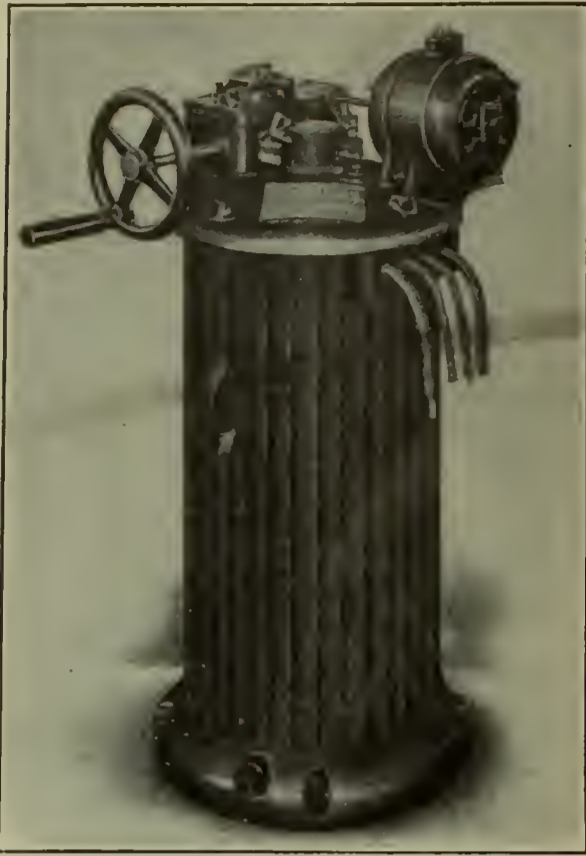

FIG. 5.

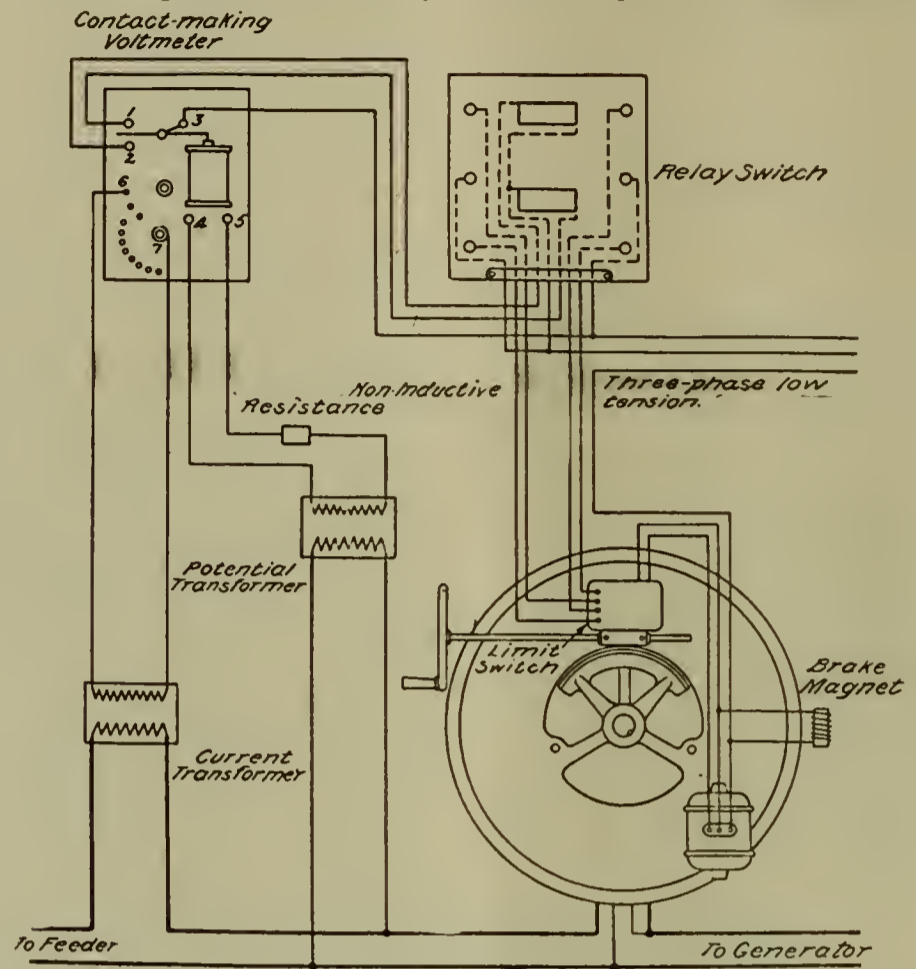

FIG. 7.

many places and the individual drive has superseded the earlier forms.

The arrangement of automatic relay and motor-control circuits which is required is shown in Fig. 7. The

switch, which in turn starts the motor, moves the regulator and raises or lowers the feeder pressure.

The series coil is made adjustable to

bus pressure with hand- or remote-controlled feeder regulators.

The load on lighting feeders usually does not vary rapidly, and automatic control of the bus pressure suffices to smooth out the small variations of pressure, so that the operator can easily care for variations due to gradual changes in the feeder load by hand regulation.

The automatic regulator devised by Tirrell has proven very successful in the control of bus pressures. The general scheme of connections for this device is illustrated on Fig. 8, and the action may be described thus:

The secondary circuits of the potential and current transformers of the generator are led through a solenoid in a compounding relation. The current section is subdivided so that different rates of compounding may be secured. A movable plunger is actuated by this solenoid, which in turn actuates a counterweighted lever, the opposite end of which is equipped to make electrical contact in a relay circuit. The other contact terminal of this relay circuit is carried on a similar lever, which is actuated by the plunger of a direct-current solenoid. This solenoid receives current in proportion to the pressure at the exciter terminals. The relation of these contact-making levers is such that increased pressure at the exciter brushes tends to open the relay circuit, while

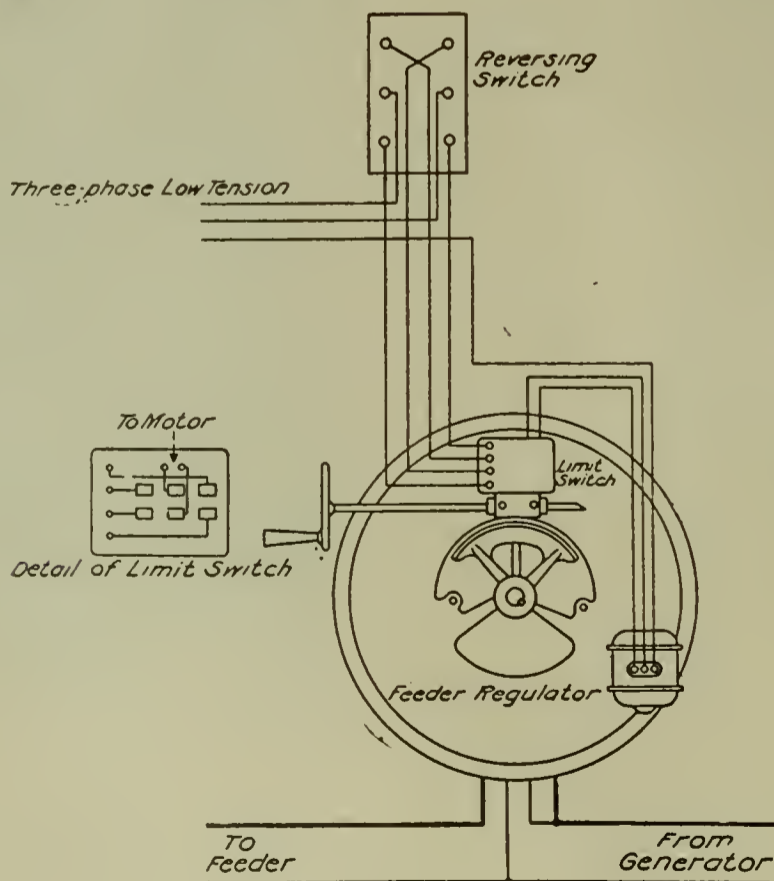

FIG. 6.

solenoid of the contact making voltmeter contains a plunger which is actuated by an adjustable series winding in opposition to a potential wind-

permit its adaptation to feeders of various sizes and lengths.

In practice the maintenance of relay contacts has been found somewhat



increased pressure at the main generator terminals tends to close this relay circuit. The closing of the relay circuit demagnetizes the relay as one arm of the relay is continuously excited in the opposite sense. As soon

a portion of the exciter field rheostat.

Where there are several units in parallel in a station the regulator may be applied to the exciter for a part of them and the bus regulated for

sure at each feeder end, without the use of pressure wires, has made the line-drop compensator an invaluable adjunct of alternating-current systems. The function of the line-drop compensator is to introduce into the feeder voltmeter circuit a counter electromotive force which shall reduce the reading of the voltmeter by an amount equivalent to the line drop, and therefore indicate to the station operator the pressure delivered at the feeder end. The compensator circuit is a miniature of the feeder itself, the pressure transformer representing the bus bar; the compensator, the line; and the voltmeter, the load. Since the feeder has both resistance and inductance the compensator must have two sections representing non-inductive and inductive drops. These sections are subdivided into 10 or 20 divisions, representing 1 per cent. or 2 per cent. each, and equipped with dial switches, so that they can be adjusted to correspond with the drop in any feeder having a full-load drop of 1 to 24 per cent. The counter electromotive force is produced by passing current from the secondary of the feeder current transformer through the two sections of the compensator in series.

The inductive, as well as non-inductive drop, being compensated for by the apparatus, the indications of the voltmeter are correct at all loads and at any power factor.

The details of the compensator have been worked out differently by two

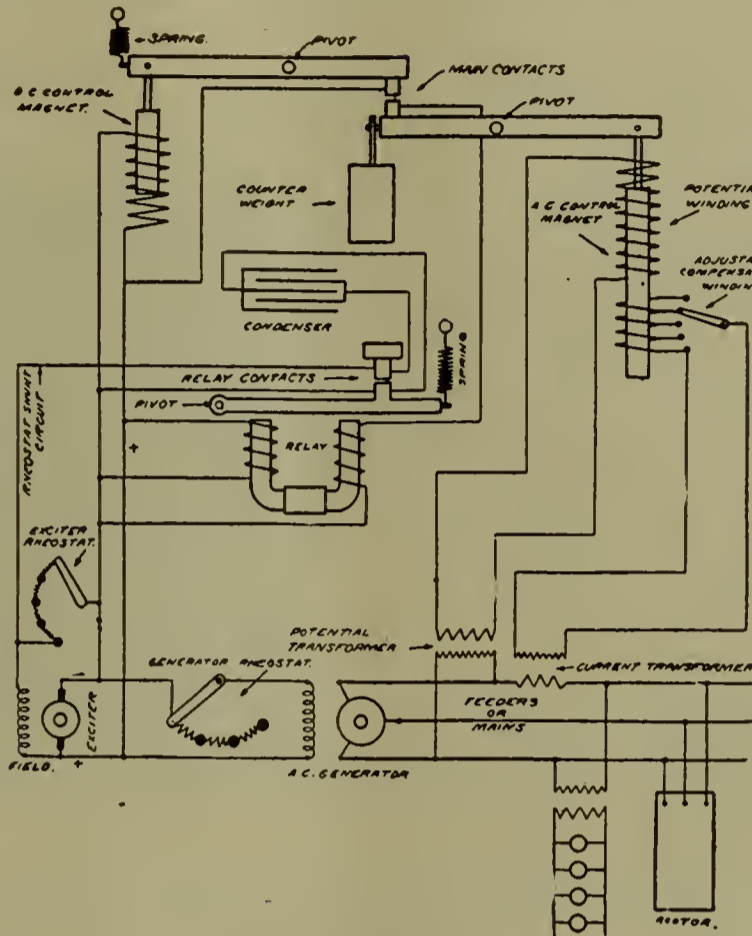

FIG. 8.

as the poles of the relay are demagnetized its armature is withdrawn by a spring. This closes a circuit which shunts the field rheostat of the exciter and greatly increases the terminal pressure at the exciter brushes. This increases the pull of the direct-current solenoid plunger and opens the relay circuit, thus weakening the pull. The result is a rapid vibratory action, which is kept up continuously at a constant rate while the load remains constant. As the load increases the current winding on the alternating-current solenoid exerts an increased pull on the plunger, which causes the lower contact of the relay circuit to move up toward the other contact and thus close the relay circuit sooner. This raises the exciter pressure and thereby the generator pressure until it has been restored to normal. The vibratory action continues as before, but the contacts are working in a slightly higher position in space, thus forming a "floating contact."

A condenser is used to diminish the action of the arc at the contact which shunts the exciter rheostat.

The ability of the shunt contacts to break the circuit is the limiting feature of the apparatus. This limit is reached at about 50 kw. on the exciter. Above this two or more breaks must be used in series, each shunting

constant pressure, with the series coil of the alternating solenoid cut out. With this arrangement the bus pressure may be maintained constant at

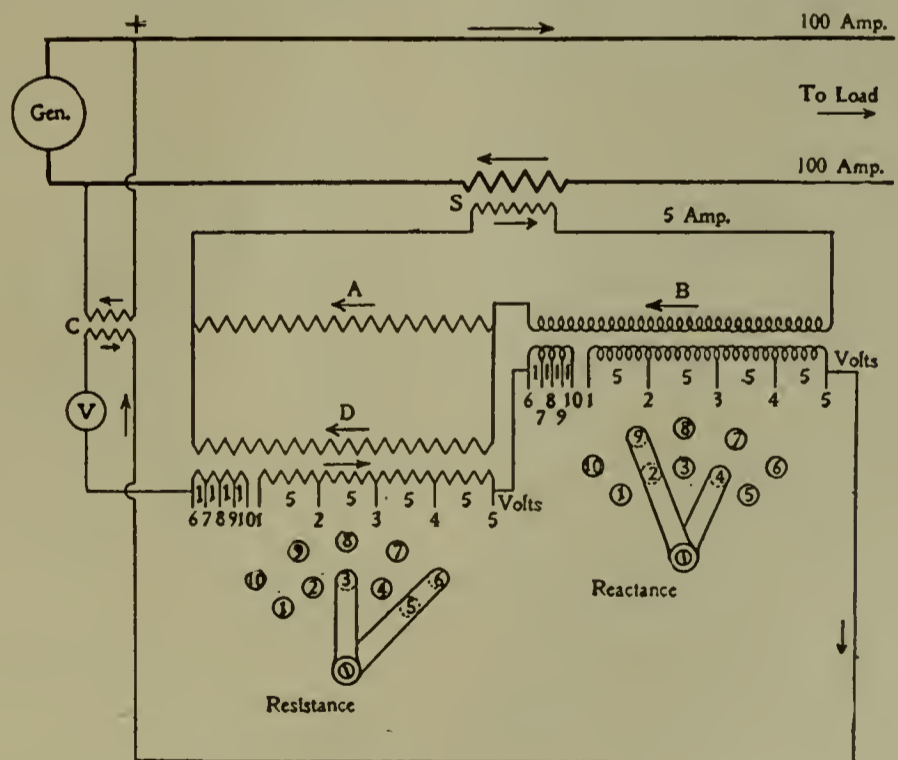

CONNECTION DIAGRAM OF COMPENSATOR, 24 PERCENT COMPENSATION

FIG. 9.

any desired point by the insertion of an adjustable resistance in the pressure circuit of the alternating solenoid.

The feasibility of having at the station an accurate indication of the pres-

sure at each feeder end, without the use of pressure wires, has made the line-drop compensator an invaluable adjunct of alternating-current systems. The apparatus as perfected by the originators of the device, the Westinghouse Electric & Manufacturing Company, is illustrated diagrammatically in Fig. 9.

This company provides compensators for a maximum drop of 6, 12, 24 or 36 volts, the one illustrated in Fig. 9 being a 24-volt compensator.

The current from the secondary of the current transformer *S* passes through the inductive section *B* and the non-inductive section *A* in proportion to the load on the feeder. The ratio of the current transformer must be such that at its full-rated load the

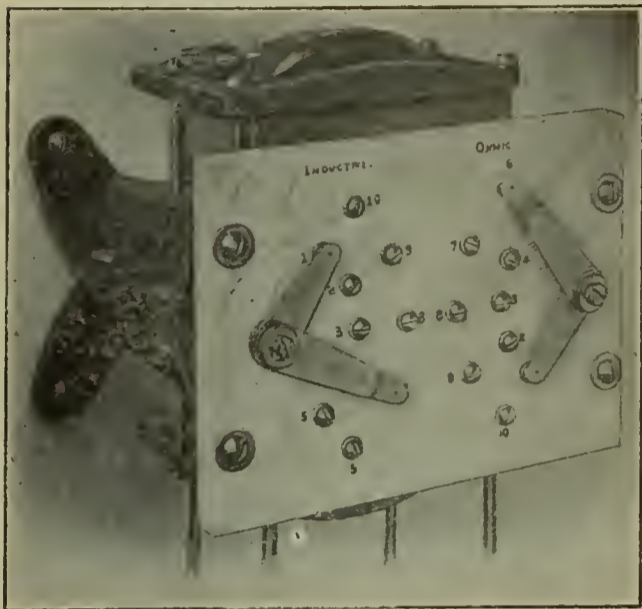

FIG. 10.

current in the secondary will not exceed 5 amperes. The inductive section is wound on an iron core, which serves also as the core of a pressure transformer.

The secondary winding is divided into four sections of five volts each and four sections of one volt each. The five-volt terminals are connected to the contacts numbered 1, 2, 3, 4, 5 and the one-volt terminals to the contacts numbered 6, 7, 8, 9, 10. The arms may be independently adjusted, thus permitting any setting from 1 to 24 to be made, as in the following table:

Switch Points	Per Cent. Compensation	Switch Points	Per Cent. Compensation
5-6	0	3-8	12
5-7	1	3-9	13
5-8	2	3-10	14
5-9	3	2-6	15
5-10	4	2-7	16
4-6	5	2-8	17
4-7	6	2-9	18
4-8	7	2-10	19
4-9	8	1-6	20
4-10	9	1-7	21
3-6	10	1-8	22
3-7	11	1-9	23
		1-10	24

The non-inductive section is similarly equipped and the settings are made in the same way.

The pressure from the main pressure transformer *C* passes through the feeder voltmeter to terminal 6, through the two movable arms to 3, through the portion of the non-inductive section, which is included between 3 and 5, thence through the inductive section by a similar path

through the portions between 9 and 6, and between 4 and 5. It then returns to the pressure-transformer. In making this circuit the impressed pressure has been opposed by a counter electromotive force of 10 volts in the non-inductive section and by 8 volts in the inductive section.

The reading of the voltmeter is, therefore, reduced by the same amount as would be a voltmeter connected at the end of a feeder having a resistance drop of 10 volts (secondary) and a reactance drop of 8 volts at full load. If the normal secondary pressure delivered to the feeder voltmeter is approximately 100 these drops are also percentages of the secondary pressure, but if the secondary pressure on the voltmeter is 110, or any other appreciably different voltage, the compensator figures cannot be considered as percentages of the secondary pressure.

The general external appearance of this type of compensator is illustrated in Fig. 10.

The compensator, as worked out by the General Electric Company, is somewhat simpler in construction. The general scheme of connections is illustrated in Fig. 11.

In this type the current from the main current transformer is reduced in the ratio of 5 to 1 by a current transformer inside the case of the compensator. There is but one movable arm on each section and 8 points each of which represents 3 volts when 5

eration of setting is easily accomplished by any station attendant without danger of confusion or reference to a table of settings, corresponding to various percentages of compensation. The general appearance of this type is shown in Fig. 12.

#### PROBLEM.

With a feeder of No. 0 wire, 5000 feet long, overhead wires 12 inches



FIG. 12.

apart, pressure 2200 volts at feeder end, frequency 60 cycles, current transformer rated 100 to 5 amperes, pressure transformer rated 2200 to 110 volts, how should the compensator be set?

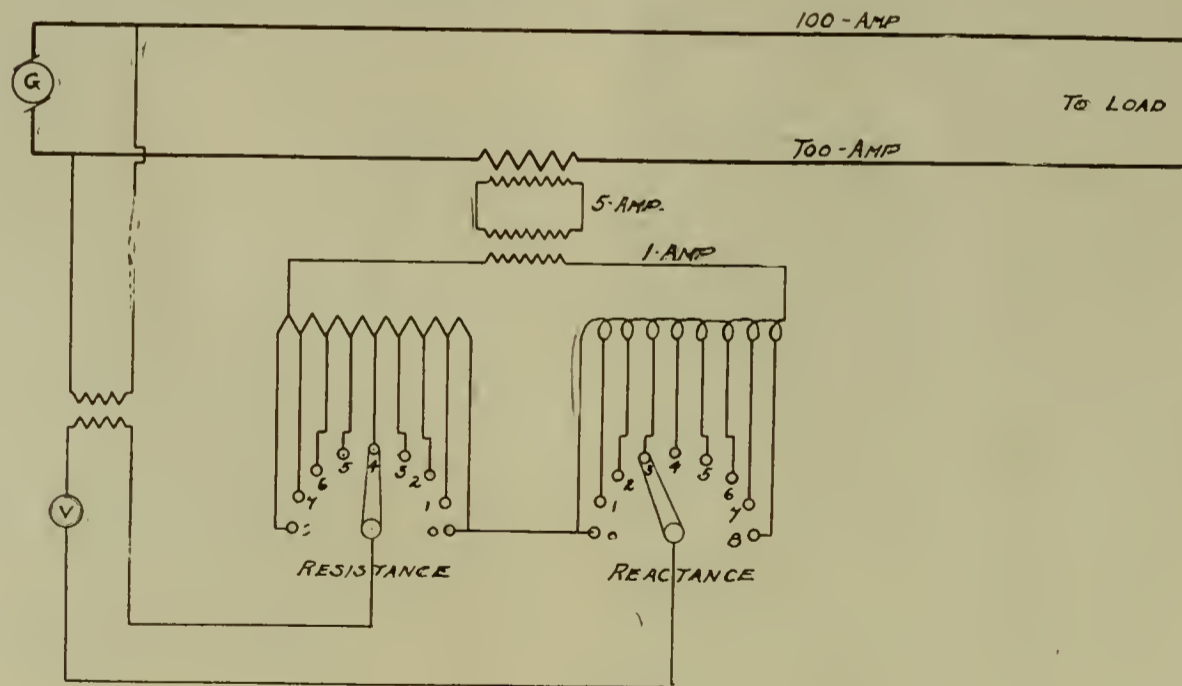

FIG. 11.

amperes are following in the compensator.

The compensator in Fig. 11 is set so as to introduce in the voltmeter circuit an inductive counter electromotive force of 9 volts and a non-inductive counter electromotive force of 12 volts when the feeder is carrying full load.

The points being numbered, the op-

The full-load rating of the compensator being 5 amperes, that of the feeder is 100 amperes. The ohmic drop on a No. 0 feeder at 100 amperes is 0.2 volts per ampere per 1000 feet of two-wire circuit. Hence the ohmic drop is  $100 \times 5 \times 0.2 = 100$  volts or 4.5 per cent. Likewise the inductive drop is  $100 \times 5 \times 0.22 = 110$  volts or 5 per cent.

If the primary mains are designed to give not over 2 per cent. ohmic drop, the transformers 2 per cent. and secondary mains 2 per cent., the average ohmic drop from the feeder end to the consumer's premises should be about 3 per cent.; the inductive drop

premises. In this case the total ohmic drop is  $4.5+3=7.5$  per cent., while the inductive drop is  $5+3=8$  per cent.

If a Westinghouse 24-per cent. compensator were used, the setting of the resistance section would be  $7\frac{1}{2}$

the points have a value of three volts each, and the setting must be made on the nearest point. In this case the arm of each section would, therefore, be set at the third point.

On a two-phase four-wire feeder the method of connection is similar to that used in the single-phase feeder, except that one equipment is required for each phase. The method of calculating the setting for each phase is the same as in the case of a single-phase feeder. With a three-wire two-phase feeder, which always carries a balanced load, a compensator is required in the two phase wires only. But with unbalanced load one is required in each of the three wires. The connections should be as shown in Fig. 13 when the load is unbalanced.

In calculating settings it must be borne in mind that the values of resistance and inductance per 1000 feet used in the case of the single-phase feeder are based on two wires, whereas in a three-wire feeder each compensator corrects the drop in one wire only. The values used for single-phase feeder resistance must, therefore, be divided by two before being applied to a three-wire feeder, whether two phase or three phase.

In case the common wire is equipped with a current transformer having a higher ratio than the other wires, this must be taken into account. Likewise if the common wire is larger than the other wires, the proper values must be used for this conductor. The allowance made for drop in the primary mains, transformers, secondaries, etc., should be added to the calculation for the phase wires of the feeder only as it is in phase with the drop in these wires.

With a two-phase feeder of three No. 0 wires similar in other respects to the single-phase feeder previously described, and with a current transformer in the middle wire rated at 150 to 5 amperes, the ohmic drop in the middle wire would be  $5 \times 150 \times 0.1=75$  volts or 3.5 per cent., the inductive drop would be  $5 \times 150 \times 0.11=82$  volts or 4 per cent. The drop in the outer wires would be  $5 \times 100 \times 0.1=50$  ohmic and 0.55 inductive, or about 2.5 per cent. Adding the allowance of 3 per cent. for drop in the distributing mains, the compensator on the outer or phase wire should be set at 6 per cent. on each dial of the compensator. The compensator on the middle wire should be set at 4 per cent. on each dial.

In the case of a three-wire three-phase feeder carrying unbalanced load, a compensator is required in each wire. For instance, if the feeder previously used for illustration were a

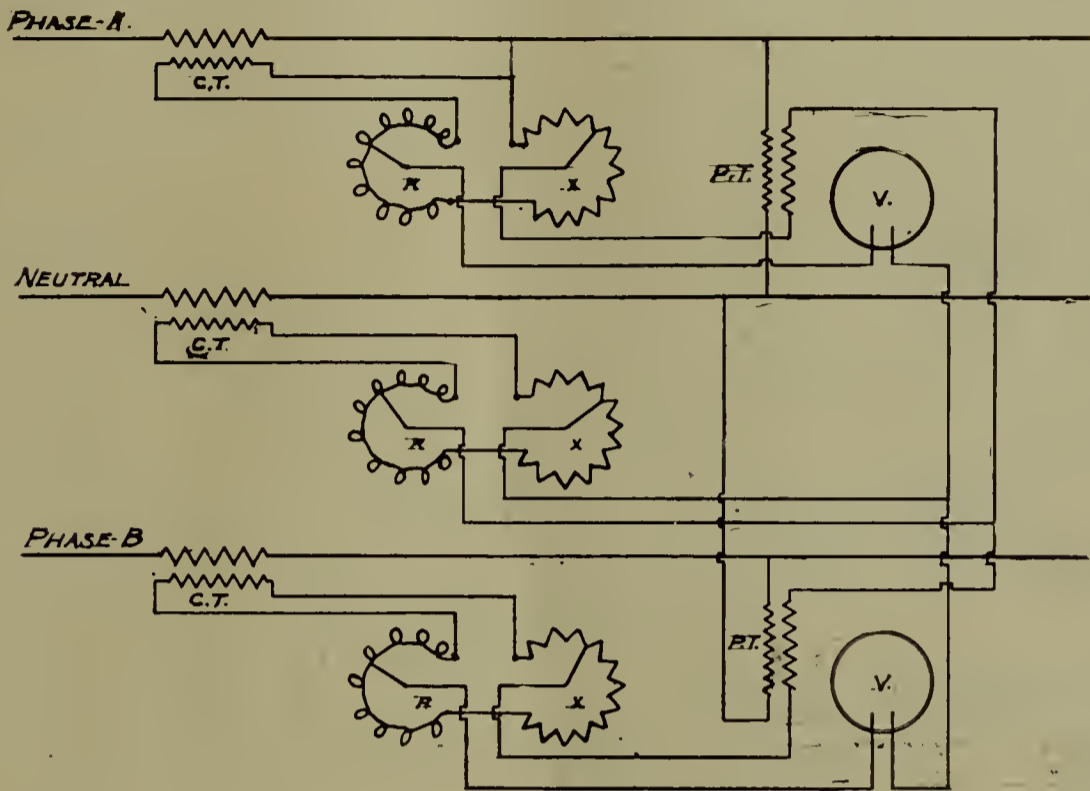

COMPENSATOR CONNECTIONS FOR TWO PHASE UNBALANCED SYSTEM.

FIG. 13.

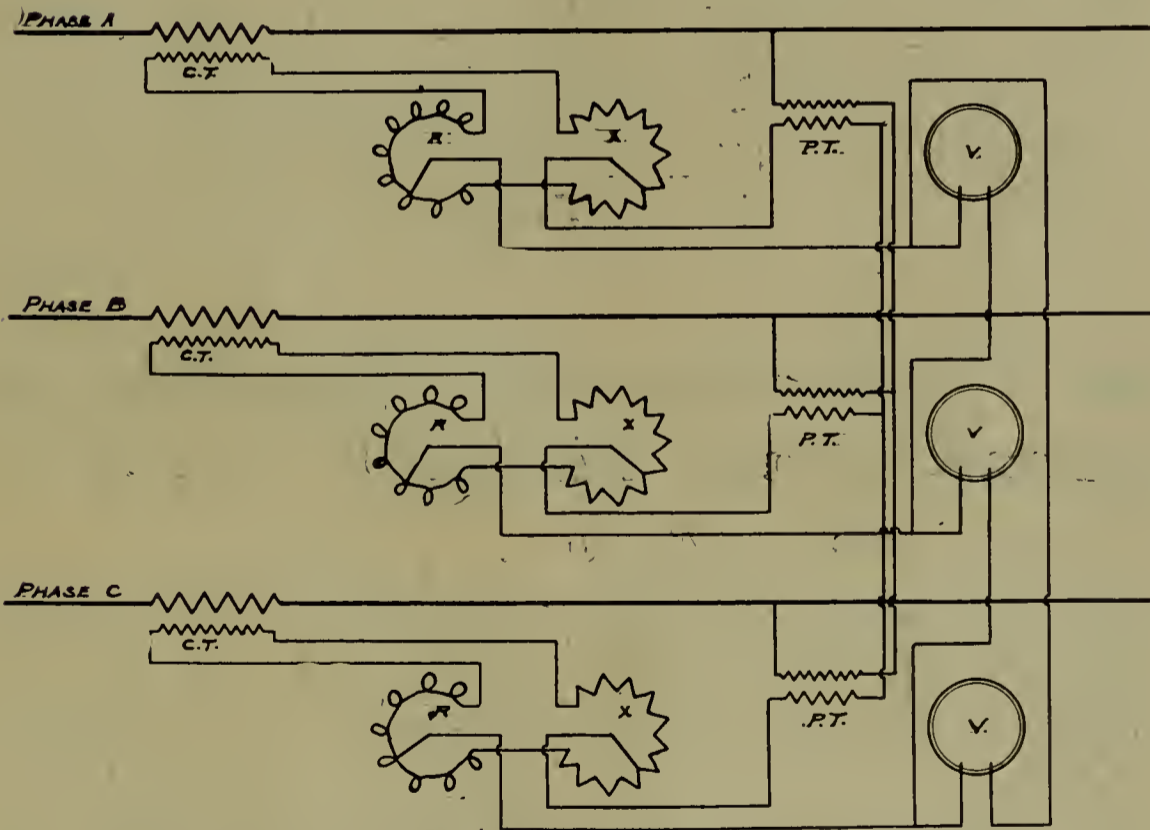

COMPENSATOR CONNECTIONS FOR THREE WIRE THREE PHASE SYSTEM

FIG. 14.

should be about 3 per cent. also. Assuming that these averages are applicable to the major portion of the distributing mains, they may be added to the drop on the feeder, and the compensator set so that the drop on both feeder and distributing system will be taken into account. The pressure may thus be regulated to give constant pressure at the average consumer's

per cent. of 110 or 8 volts, and of the reactance section 8 per cent. of 110 or 9 volts. The resistance arms would therefore be set at 4-9 and the reactance section 4-10. The operator will then keep the feeder voltmeter at 110 volts at all loads, this being maintained as a standard pressure.

With a General Electric compensator having eight points on each part,

three-wire three-phase feeder the ohmic drop in each wire will be  $5 \times 100 \times 0.1 = 50$  volts, and the inductive drop 55 volts. These values are respectively 2.2 per cent. and 2.5 per cent. of the working pressure 2200 volts. In this case the drop on each wire affects the pressure on two of the three phases. The compensators must, therefore, each interpose a counter electromotive force in the voltmeter circuits in proportion to the drop in the phase wire which it represents. This drop must be expressed as a percentage of the working pressure.

The diagram of connections for this system is illustrated in Fig. 14.

The allowance for drop in distributing mains must be divided between any two compensators, as it is in phase with the working pressure. 1.5 per cent. should, therefore, be added to the 2.2 per cent. ohmic and 2.5 per cent. inductive drops, making the ohmic setting 3.7 per cent. and that of the inductive 4 per cent.

In a three-phase four-wire system operating at 2200 volts between each phase and the neutral, the method of calculating the drop is as follows: With a feeder of four No. 0 wires running 5000 feet from the station as a three-phase feeder, the drop in each wire is 50 volts ohmic and 55 volts inductive. The working pressure being 2200, this is 2.5 per cent. If the entire load of the feeder is delivered from this center of distribution the compensator on each phase wire should be set at  $2.5 + 3.0$ , or say, 6

per cent. on each dial. That on the neutral should be set at 2 per cent. on each dial. If, however, the A-phase branches off with a neutral to a single-phase center of distribution 2000 feet beyond, there must be added to the A-phase setting  $100 \times 2 \times 0.2 = 40$  volts, or 2 per cent., making it 8 per cent. on each branch. If the other phases branch to similar centers of distribution at different distances, the drops must be figured as if they were single-phase feeders from the end of the three-phase trans-

mission to the single-phase center of distribution. These drops must then be added to the three-phase drop above calculated. On four-wire feeders, which reach the limit of three-phase transmission within 3000 feet of the station, it is usually unnecessary to install a compensator on the neutral wires, as the neutral drop is negligible, even with a considerably unbalanced load.

The connections for a four-wire three-phase feeder are shown in Fig. 15.

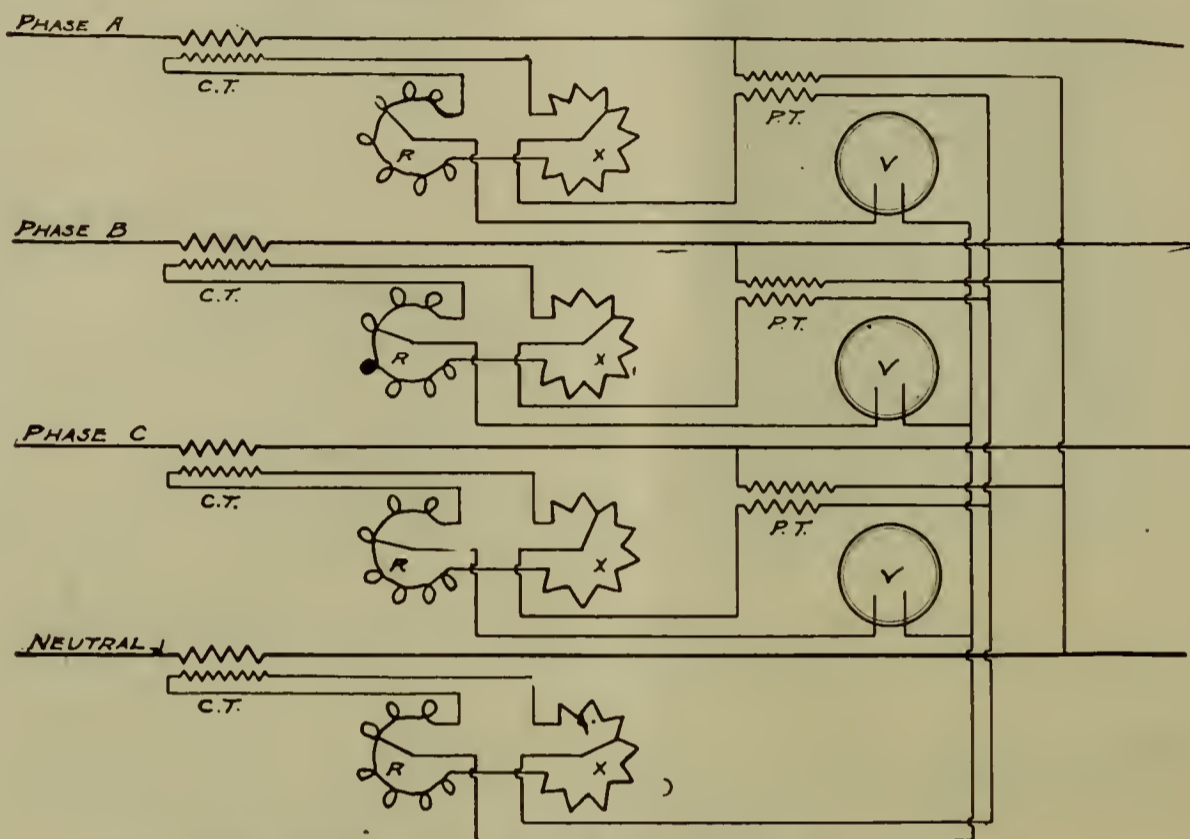

COMPENSATOR CONNECTIONS FOR FOUR WIRE THREE PHASE SYSTEM

FIG. 15.

## Some Points in the Connecting and Repairing of Alternating-Current Motors.

M. O. BUCKLEY

When a direct-current motor is spoken of as four-pole or six-pole, it is understood that the stationary, or field part, has that number of poles in it. These poles may be seen with the eye as large solid coils surrounding a metal core, but when a four-pole or six-pole alternating-current motor is examined no poles are visible. The field is then found to be an apparently continuous winding of wire, such as occurs upon the armature of a direct-current motor. The poles are there, nevertheless, and perform the same duty as in the direct-current machine. The reason they are not visible is because the coils are wound flat in such a manner that the layers of any one pole overlap the windings of the ad-

jacent poles, producing in the finished machine the appearance of a continuous winding. If the connecting leads from the terminal block are



FIG. 1.—TWO-PHASE; THREE-PHASE STAR, OR Y; THREE-PHASE DELTA CONNECTION.

followed back, it will be found that in a single group perhaps five coils are joined together and connected to a

similar group some distance beyond. In fact, if the leads are traced from the terminal block it will be seen that the seemingly continuous winding is cut up into many small groups.

Each group of windings represents a collection of coils so connected by short stub connectors that the current passes through each coil of a group in the same direction. The coils of a group are, however, distributed in successive slots. Each group represents a pole, every other one in a given phase being of one polarity and the next of opposite polarity. Thus we have north and south poles as in the direct-current motor.

The grouping of these coils is shown

diagrammatically in Fig. 1. It will be observed that in the two-phase motor the two phases are separate. It is unusual to connect them. In the three-phase machine it is customary to connect one end of each phase to a

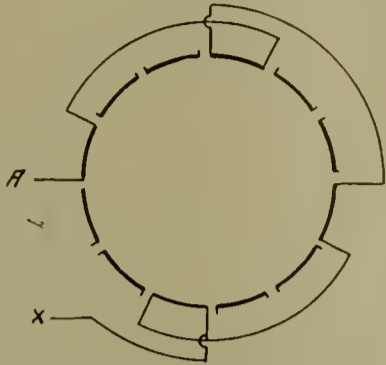

FIG. 2A.—THREE-PHASE, FOUR-POLE, 440-VOLT—ONE-PHASE CONNECTED.

common connection. The free ends are connected to the terminal block. This method of connection is known as the Y or star connection. Where all six terminals of the winding are connected to the terminal block we have the delta connection, the use of which is explained later.

Fig. 1 shows the windings of a four-pole two-phase and of a four-pole three-phase machine connected in star and in delta. Six, eight, ten or more poles on each leg would simply include that many additional north and south poles. The reason for reversing every other phase connection is to reverse the current through that pole and thereby produce a pole of opposite polarity from the one before it. Of course, north and south pole refers to a momentary condition only, as each reversal of current through a phase winding reverses the polarity of each pole.

We will apply a Y three-phase winding to a stator (stationary part) having 24 slots, and therefore 24 coils, to be connected to each pole. The whole winding may therefore be

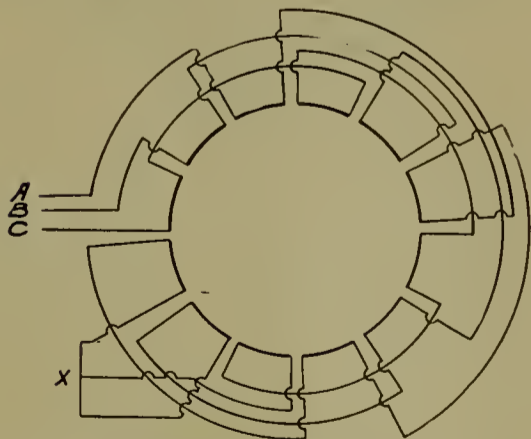

FIG. 2B.—THREE-PHASE, FOUR-POLE, 440-VOLT—ALL PHASES CONNECTED.

paired off into groups of two coils in series. A start may be made from any point, as the position of a pole with reference to any mechanical line of the motor has no bearing at all. Fig. 2 A results in winding when

each pole of one phase is hooked up, and Fig. 2 B when each phase is similarly connected.

110-, 220-, 440-, 550-VOLT CONNECTIONS.

Suppose each set of coils on a pole has 55 ohms resistance with four poles per phase, there would be a total of 220 ohms per phase. Then, neglecting inductance, etc., for the sake of simplicity, 440 volts divided by 220 volts equals two amperes. See Fig. 3. If 220 volts were applied to the motor terminals, only one ampere would flow. But if each two pairs of poles in series were paralleled with each other pair, as shown in the diagram, Fig. 5, then the same current would flow and the same torque would be developed.

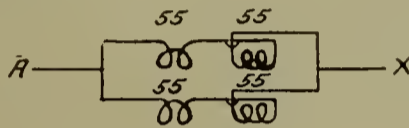

FIG. 3

Again, if all poles per phase are placed in parallel, as in Fig. 6, the result would be the same. This is the plan upon which induction motors are wound, and as shown two amperes per coil will be obtained to give the required ampere turns for 110, 220 or 440 volts. It follows from the above that a motor wound, or put on the

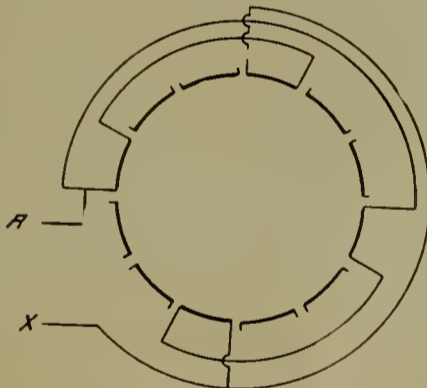

FIG. 4.—THREE-PHASE, FOUR-POLE, 220-VOLT.

market as a machine for one voltage, may be changed over to a motor of similar speed and horse power, but for another voltage, by simply changing the loops to all series, series-parallel or parallel, as the case may call for. In motors of many poles, the number forming a group for any voltage will, of course, be one-half or one-fourth of the whole. For example, a 16-pole motor would have eight in series, or one leg for 220 volts, and four in series for each 110-volt leg. Five hundred and fifty volt motor windings are considered as "special" by manufacturers, for no combination of groups will produce the right result for that voltage. A six-pole motor, or any machine having a winding which cannot be properly subdivided, must evidently have one particular special winding. If designed for 440 volts,

with six poles in series, then three poles in series will give the 220-volt combination and the 110-volt winding would be special. Some manufacturers, however, obtain the required resistance for 220 volts by ar-

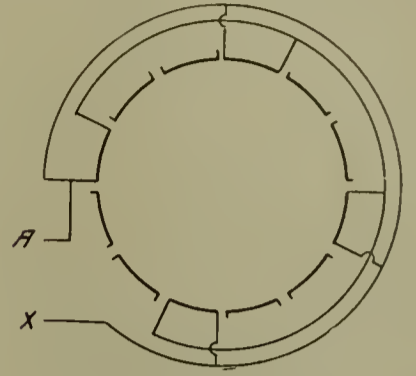

FIG. 5.—THREE-PHASE, FOUR-POLE, 110-VOLT.

ranging for the six poles to be in series at that voltage, in which case the three poles in parallel would give a 110-volt winding and call for a special one for 440 volts. A repair or test man on getting a motor of this sort would have to follow the loops to determine which method had been used.

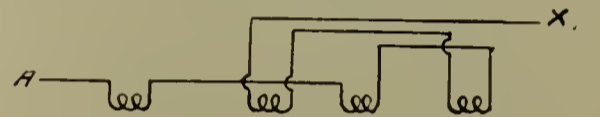

FIG. 6.

Some makers vary the method of connecting groups shown in Fig. 1 by connecting the north pole coils together, and reversing through the south pole coils together, as shown for one phase of a winding at Fig. 7. This method of connecting is shown in several of the accompanying diagrams and gives the same result as before.

The reason for using the Y winding in three-phase work is evident. In

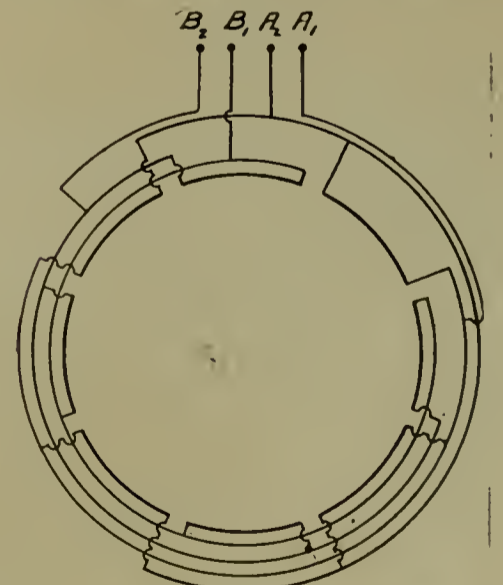

FIG. 7.—TWO-PHASE, FOUR-POLE, DOUBLE-PARALLEL WINDING.

the delta each leg has to withstand the full voltage of the terminals. In the Y we have a partial effect of two legs in series across the terminals, so that each phase has to be insulated

only for  $\frac{1}{\sqrt{3}}$  of the line voltage, or practically 58 per cent. This materially favors the insulation of motors with the windings connected in Y.

This observation takes us into the usage of the delta winding. We have explained how pole groups are built on the unit plan. In a Y winding it is evident that phase A-A would not have 440 volts across its ends, but 58 per cent., or about 255 volts. If a flow of two amperes were required, as in our example, then wire of lower resistance or slightly heavier cross section would have to be used than before. It often happens that at the end of a long transmission line, either 220 or 440 volts, the standard voltages cannot be obtained, due to a heavy drop in the line or other effect. Suppose, for example, that in attempting to obtain 220 volts on the secondary only 180 volts or 250 volts could be secured. If one 220-volt motor were placed on a 180-volt line, the horse

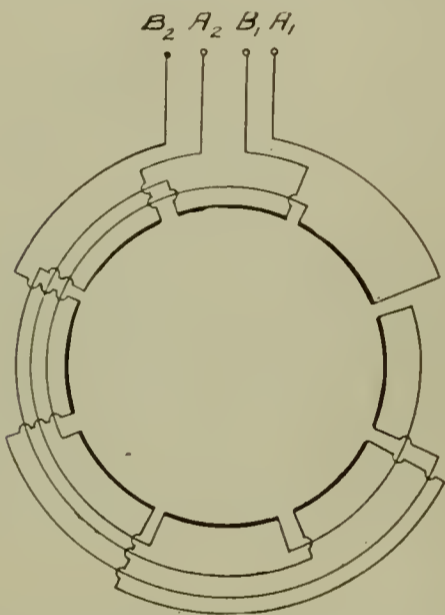

FIG. 8.—TWO-PHASE, FOUR-POLE, SERIES WINDING.

power would be reduced in the ratio of  $(220)^2$  to  $(180)^2$ ; as nominal is to actual horse power. (Horse power varies as square of voltage in alternating-current motors.) If a 20-h.p. motor were being considered, it would have its rating reduced to about 13½ h.p. On the other hand, if this same motor were placed on the 250 volts, its rating would change approximately to 26½ h.p. Neither result would be desirable, for there would likely be too little power in one case and too much of a tendency in the other case to load up the motor with more work than its windings would stand.

If, however, the motor were connected with all poles in series for 440 volts and a delta connection used, the result would bring the windings to within a few volts of what would be required. It is customary to use

a delta connection only in such a case as this.

Most single-phase motors are in reality two-phase machines. The "running" winding will have many coils per pole and the "starting" winding few coils. In every other respect they are to be treated as two-phase motors. The General Electric motor has a straight three-phase winding, as was explained on page 25 of the January issue of THE ELECTRICAL AGE. In this motor the two ends of each phase are brought out of the motor, with the proper connections made in the starting box. The Wagner repulsion motor and other single-phase motors have their windings connected in accordance with the general plans described, and no trouble will be encountered if the leads from the terminal block are traced back in the winding.

We have discussed heretofore only stator windings. Some types of motors have wound rotors or even armatures with commutators. The explanation given above, however, also explains wound rotors, as an inspection with the eye will quickly show. Repulsion type motors with armatures having commutators are to be considered as if the armatures were for direct-current machines.

#### MOTOR TROUBLES.

The chief troubles of alternating-current motors are as follows:

##### (1) Short-circuited coil.

This will show itself quickly by heat, as the short-circuited section will act as the closed secondary of a transformer. The hand will readily detect the faulty spot or a sizzling of insulation if it continues very long.

##### (2) Open Circuit.

If in the stator of a two-phase or Y-wound three-phase motor, the machine will not start. If delta-wound it will start, but the torque will be reduced. If under the latter condition the motor had to carry nearly a full load, it would not come to speed. Again, ammeter readings will show open circuits in the first two cases, and unbalanced readings on the delta.

If in the rotor (wound rotor type) open circuits or unbalancing will show up on the ammeter. If all phases are open, of course the motor will not start at all.

##### (3) Reversed Phase.

If a part or the whole of one phase is reversed, the torque will be affected. If tested with an ammeter, unbalanced currents will be obtained when the motor is running. This trouble may also be located by tracing back the leads from the terminal block to find

if the connections have been correctly made for the proper theoretical diagram. The rotor windings are similarly traced.

##### (4) Grounds.

Open up all phases and test for grounds in accordance with the usual tests for such purposes.

##### (5) Humming.

If there is a defective leg in any phase, so that full speed is not obtained, then the motor will hum quite loudly. Methods described above must then be used. If the motor attains full speed and hums, it probably means loose laminations. The holding bolts must now be tightened or wedges driven in to take up space. In rare cases a few laminations may be jammed over with a cold chisel and hammer, in order to tighten up the core. This latter is only a method of last resort, as the insulation of the windings is apt to be injured by this procedure.

If the rotor is off-center with respect to the stator, there will be magnetic unbalancing and loud humming. This is easily remedied by turning up the machine so that the air gap is uniform at all points.

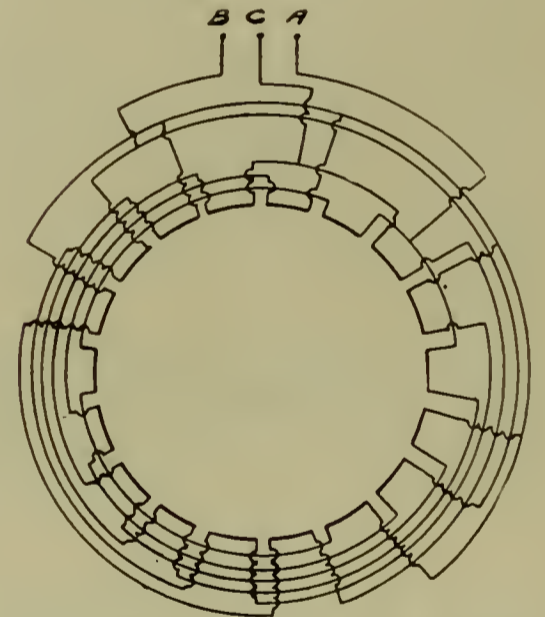

FIG. 9.—THREE-PHASE, SIX-POLE, PARALLEL WINDING.

Motors from about one horse power to 300 h.p. are easily repaired away from the manufacturers' shop by the use of machine-made coils. Very small motors require many turns of small wire, and these are wound into the slots by hand. Such a winding, when completed, by being dipped and baked becomes so hard that it is almost impossible to replace one coil without rewinding the whole motor. In very large motors the coils, when "set," become so hard that it is extremely difficult to replace a defective one. In such cases a single coil may be dug out of the windings and the

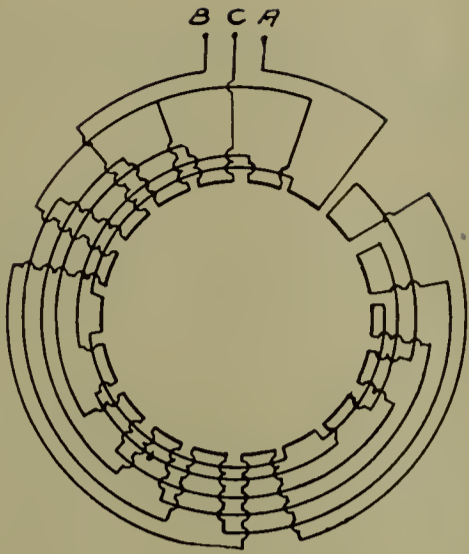

FIG. 10.—THREE-PHASE, SIX-POLE, SERIES WINDING.

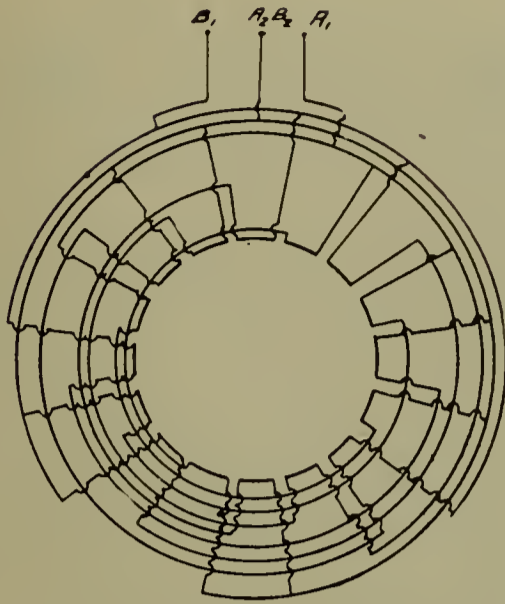

FIG. 13.—TWO-PHASE, EIGHT-POLE, THREE-WIRE, DOUBLE-PARALLEL WINDING.

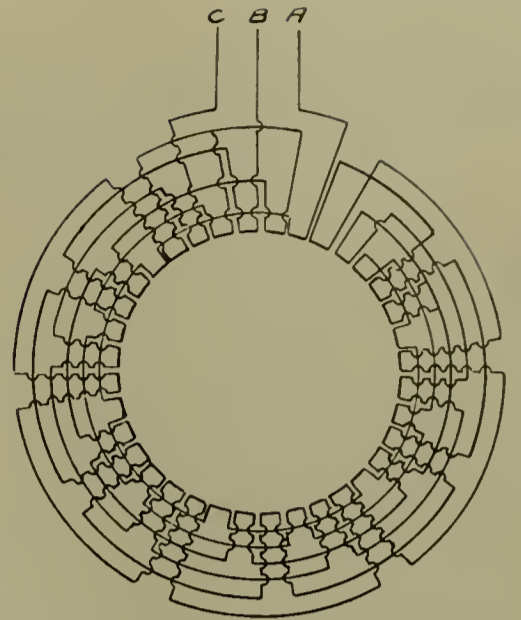

FIG. 16.—THREE-PHASE, TWELVE-POLE SERIES WINDING.

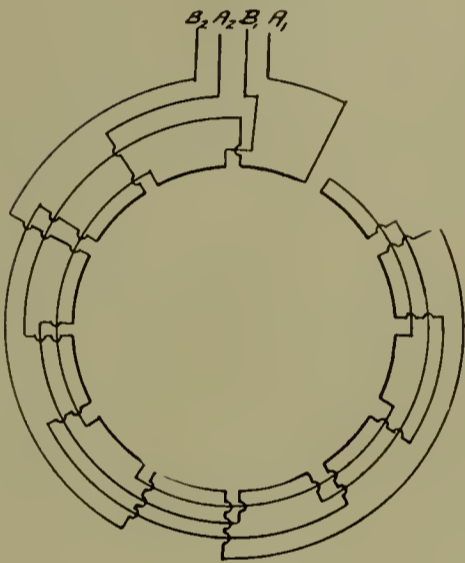

FIG. 11.—TWO-PHASE, SIX-POLE, SERIES WINDING.

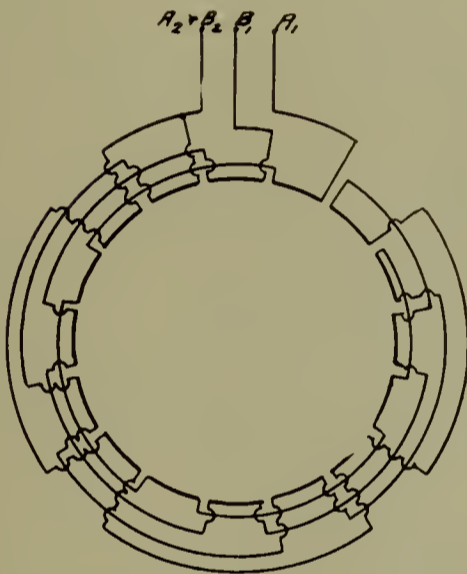

FIG. 14.—TWO-PHASE, EIGHT-POLE, THREE-WIRE, SERIES WINDING.

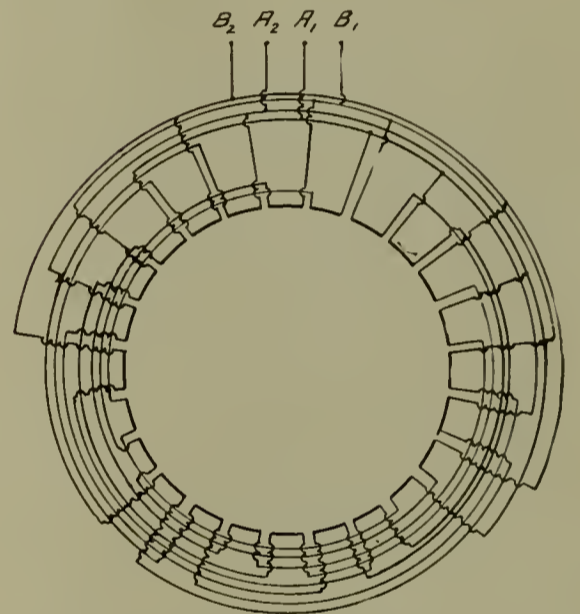

FIG. 17.—TWO-PHASE, TWELVE-POLE, DOUBLE-PARALLEL WINDING.

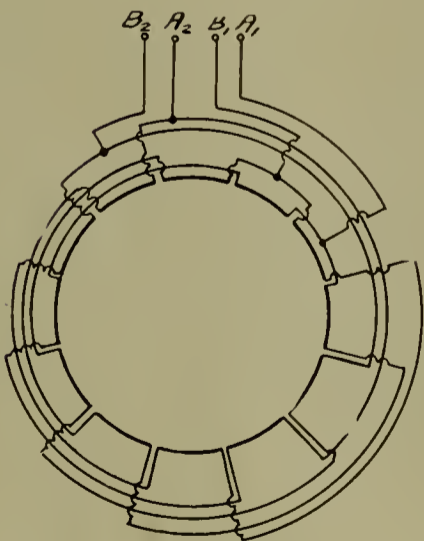

FIG. 12.—TWO-PHASE, SIX-POLE, PARALLEL WINDING.

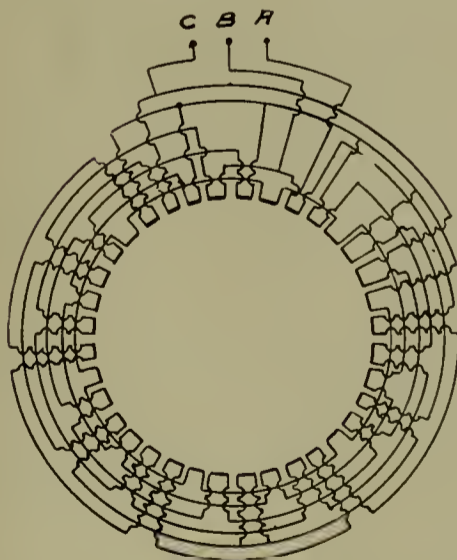

FIG. 15.—THREE-PHASE, TWELVE-POLE, PARALLEL WINDING.

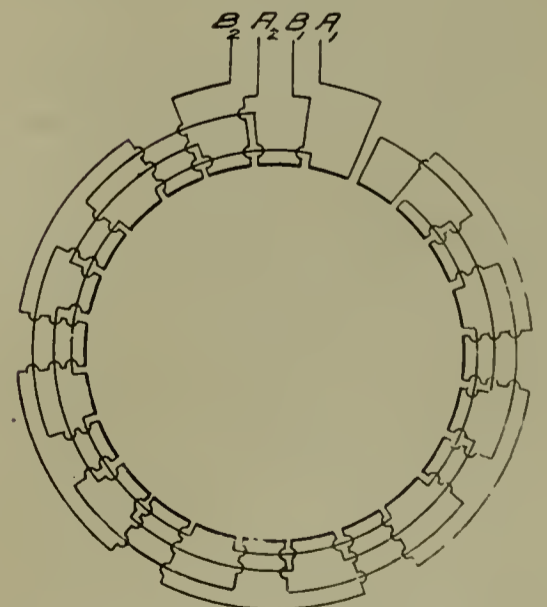

FIG. 18.—TWO-PHASE, TWELVE-POLE, SERIES WINDING.

two adjacent coils bridged across the empty gap. This is common practice where the coil removed will not re-

duce the resistance of a given phase more than five per cent. If a parallel or series-parallel winding is used, a

reduction of one or two per cent. will not unbalance enough to cause trouble of any kind.

# Investigation by the Public Service Commission of the Lighting Companies of New York

THE inquiry of the Public Service Commission, First District, into the affairs of the lighting companies of New York will cover the investigation into the franchises, property and operations of the companies, inquiring into the methods employed by the companies, and each of them with respect to any discrimination in rates and whether such discrimination is undue, unreasonable, or unjust; whether contracts are required of customers as a condition to service, and if so, their nature, and whether legal, just and reasonable; emergency service and auxiliary or supplemental service; regulations governing the introduction of wires upon the premises of customers and others, including the cost and charges therefor; regulations governing the discontinuance of service and also the price charged for electricity and any regulations governing the same; the kind, condition and accuracy of meters used, the condition of the currents, wires, conduits and services, and generally the methods employed by the said corporations in generating and supplying electricity and in the transaction of their business; and into the every matter and thing necessary or proper to inform the commission whether the property of a company is maintained and operated for the security and accommodation of the public, and in compliance with the provisions of law and their franchises and charters.

The first subject taken up by the commission at the initial hearing, February 26th, was the matter of breakdown service, to which the New York Edison Company objected, on the ground that the commission has no power or jurisdiction to go into this subject, in which protest several of the other companies also joined. Counsel for the commission read a letter from the New York Edison Company outlining a new service rate for "breakdown" installations. In its communication the company called attention to the fact that such a service is not a service in the usual sense, but insurance to protect customers against breakdown or overload and that it amounts to rendering the equivalent of a duplicate plant duplicated from the coal pile and boilers through the engines and generators to an independent generating and distributing switchboard, with the equivalent

of such a plant under constant steam pressure ready to serve at an instant's notice. The company calls attention to the fact that its engines and generators are always running to provide an adequate reserve, or their general service with other units revolving slowly in readiness to take up the load, all of which requires the operation of boilers, consuming steam, calling for many supply and maintenance expenditures and the constant attendance of engineers and helpers.

The tentative breakdown proposal is as follows: A service charge of \$30 annually for each kilowatt of installation connected.

In rating the installation each 16 c-p. incandescent lamp should be taken as equivalent to 50 watts; each arc lamp at 10 c-p. equivalents and each horse-power at 15 equivalents.

Within the service charge of \$30 annually, customer may consume electric current at usual rates without additional charge.

Service connections will be carried only to the building line, on which meters will be installed. Beyond this point connections must be provided by the consumer, who must furnish the throw-over switch.

The first witness, Mr. Arthur Williams, explained that the company did not distinguish between breakdown service and auxiliary service; that there were only 123 such connections, which consumed during 1907 3½ million kw.-hrs. Most of these connections were of long standing and none have been given within the last two years. Mr. Williams states that calls for this particular sort of service were very infrequent and not enough to attract any particular attention, until two years ago when the number increased and the company decided it would no longer supply such a service. The reason for discontinuing breakdown connections was given by witness as endangering the company's entire system by the possibility of having a very large installation thrown upon some part of the system not constructed for the extra load. Mr. Williams further stated that it would be absolutely necessary to provide extra service distribution for the entire amount of breakdown connection, even with 2000 buildings connected, though he was not of the opinion that it would require the full generating capacity.

In response to an inquiry as to how the company arrived at a service charge of \$30 per kw. of breakdown installation, Mr. Williams stated that one point bearing on the price was the company's average return per kw. installed, which amounts to about \$50 a year. It was thought fair to charge three-fifths of this amount for breakdown service. The \$30, however, was not based upon any exact calculation as to cost; it represents about 10 per cent. of \$300, the investment cost for service. Mr. Williams' personal opinion was that the amount should be 15 per cent. of \$300, 15 per cent. covering more closely the items of fixed cost.

Mr. J. W. Lieb, Jr., Third Vice-President of the company, was called at this point to explain what the \$30 represented and how the company arrived at this figure. He stated that the rate had been used and was, to some extent, current, it being the equivalent of the minimum guarantee that is sometimes exacted for the service of \$1.50 per year per 16 c-p. equivalent, which amounts to \$30 per year. In response to an inquiry about the \$300 a kilowatt of capacity, Mr. Lieb did not have in mind any calculations made on this line and would not undertake to explain Mr. Williams' figures. He stated that they had made detailed calculations as to the proper stand-by costs.

In response to a question whether \$30 had been arrived at by taking three-fifths of the average of \$50 per customer, Mr. Lieb stated: "That was a very important feature of the calculation, as I have already outlined. That was one point of view, and one point of view leading to the \$30 per cent. that I have already assigned, and in considering the question from the other standpoint, from the standpoints and the considerations that I have indicated, again \$30 seemed to be a reasonable figure, and it was as the result of these considerations and general consultations that the figure of \$30 was finally arrived at as a proper one to submit to the commission."

In response to a question as to whether he wished to add anything further as to the way in which this figure was attained, Mr. Lieb answered, "I think, Mr. Commissioners, I have covered that subject fully."

Mr. Hemmens, Counsel for the New



York Edison Company, at this point brought the witness to say that the \$30 charge included the use of current up to that amount, so on this basis a breakdown customer was on the same basis as another customer.

Here is a sample of some of the interesting testimony:

(Q) You would consider then that possibly the same ratio would apply to breakdown service as to ordinary service?

(A) Not necessarily, sir, possibly more.

(Q) What do you estimate?

(A) Well, I think that we had in mind that in an ordinary class of customer who would be likely to request a breakdown service which would mean, as a matter of fact, rather a wholesale consumer, that we should expect to be called upon for possibly between 60 and 75 per cent. of his connected installation.

(Q) What is the percentage of the ordinary consumer?

(A) About between 30 and 35.

(Q) You consider it would be about double in the case of the—

(A) I think it would in this class of service.

(Q) You say that is based on any data that you have?

(A) On our best judgment.

(Q) Do you know of any statistics that have been compiled to show?

(A) I have never seen any statistics as to what the demand in the case of breakdown service is, so I have no other guide than what I have indicated.

(Q) Do the facts regarding these 123 customers—would they throw any light upon it?

(A) I think not; I think not.

(Q) Why not?

(A) Because they don't show.

Mr. Weldon W. Freeman, Vice-President of the Edison Illuminating Company in Brooklyn, in response to inquiry, stated that he was connected with the company since 1889, first as assistant to the secretary and treasurer until 1895, then assistant secretary until 1898; secretary until 1902, then secretary and treasurer for one year, and his present position since 1903.

Mr. Freeman testified that their company exacted as a condition for breakdown service a minimum charge at the rate of \$1 per year per 16-c-p. lamp installed, which is equivalent to \$20 per kw.

In early operations of the company, plants were connected without any such requirements as to guarantee, but after the company learned how unprofitable these connections were the guarantee was instituted some ten or twelve years ago. Only recently had they made inquiry into the actual cost when it developed for the year 1907 each kw. connected installation cost \$21.50 per kw. per annum.

In making this estimate, all fixed charges of the company, except dividends and surplus profits, were included. Mr. Freeman stated that the maximum demand on their system was close to 50 per cent. of the total connected installations. He did not think it would be safe to figure any lower percentage for breakdown service than 50 per cent.

At the second hearing, March 5th, Mr. W. W. Freeman again took the stand for the Brooklyn Edison Company and explained how their company arrived at the \$21.50 figure. He

also explained that they had before omitted in their calculation the item of general expense, the inclusion of which would raise the stand-by charge from \$21.50 to \$27.27 per kw. He stated that the general expenses of their company were \$370,643.26.

Insurance .....	\$40,827.95
Legal expenses and... damages .....	20,600.00
Taxes .....	175,500.00
Technical expenses....	84,560.29
Street and Installation maintenance and repair expenses.....	130,548.76
Interest and discount....	672,785.29
Depreciation .....	242,931.71

With the total connection on the system at June 30, 1907, of 64,021 kilowatts.

Mr. Freeman stated that their average receipts for the year 1907 were approximately \$50 per kw.

Mr. J. W. Lieb, Jr., stated that in case breakdown connection assumed an importance which it has not hitherto had, that it would be necessary for the company to provide an automatic service switch so adjusted that an overload beyond that provided for in the contract could not be connected. An auxiliary device on the switch would give indication on the customer's switchboard when he reached within 15 or 20 per cent. of his contract capacity, so that he would have considerable warning beforehand of the limit which he had asked for. It would also be necessary to provide an arrangement with the meter in order to avoid pumping back into the system and to avoid unregistering and the turning back of the meter.

## Study Men

JOHN F. HAYFORD, C. E.

**Y**OUR predecessors who have done their part as engineers in turning the forces of nature to the use of man have changed this world from one in which the winner was the man with the brute strength and physical bravery which gave him the power to win in a hand to hand battle.\*

By turning the forces of nature to the use of man, your predecessors as engineers have changed this into a world in which the winner is the man who thinks clearly, controls himself, and may be depended upon—the man who serves rather than the man who fights.

\*From address delivered on Commencement Day, June 14, 1907, Thomas S. Clarkson Memorial School of Technology, Potsdam, N. Y.

Perhaps you think that I have exaggerated in crediting the engineer with all these changes.

Think for a moment how the steam engine and other machines are the basis of your comfort. Think of the large part they have played in furnishing you the light and heat you have in your houses, the clothes you wear, the food you eat.

The locomotive, the marine engine, the printing press and the telegraph, have made all the peoples of the world acquainted and changed them from enemies into friends.

You, graduates, have been under the continuous influence of the teachers in school and college for sixteen to twenty years—for more than three-

fourths of your life. You have acquired through their efforts. They have guided, encouraged and inspired you. To a large extent your knowledge has been selected by them and your views colored by them. You have learned from and through your teachers rather than from direct contact with facts.

During this school and college period you have learned much from books rather than from teachers. But a book is simply the ideas of a man made visible and explained in the way which seems best to him. You seldom think of the man behind the book.

If you prove to be a successful engineer you will pass through three periods with reference to the acquisi-

tion of knowledge and wisdom. First, the school and college period when you acquired through books and teachers. Second, the period comprising the first ten or more years after you leave college, the period during which you will occupy subordinate positions and be in close contact with material facts. By that close contact with facts you will gain experience which will remedy, to a considerable extent, the inevitable defects of any education furnished by books and teachers alone.

Just as rapidly and as certainly as you gain real success by showing ability to make yourself useful in the world, and by using your ability, you will find your responsibility increased, the demands upon you increased, and will find that you cannot, if you are to accomplish most, remain in direct contact with all the facts of your daily work. You will enter into the third period with respect to the acquisition of knowledge and wisdom. You will find yourself in a position where you must acquire knowledge through your subordinates who are themselves in more direct contact with the facts. The chief engineer of a railroad, the chief engineer of a great government engineering bureau, like the Reclamation Service, the head of a great technical school, necessarily sees the facts of the work for which he is responsible mainly through the eyes and brains of his subordinates. In the third, or executive, period then, as in the first, or school period, the successful engineer acquires knowledge and wisdom by utilizing the brains of other men.

When you are in school and college, you are, as a rule, learning things which were well known long before your time, you are acquiring knowledge which is well organized by the successive efforts of many men, teachers and authors. Because it is well organized knowledge, already worked over by many men, this concentrated experience comes to you from the past with comparatively little coloring, due specifically to the last author and the last teacher in the series through which it passed to you. But it does come to you with high coloring and in a distorted form, because the long series of authors and teachers have, as a rule, belonged to one profession—teaching—because they have all been thinkers, rather than doers. It is within your power, to a great extent, to remove the inevitable false coloring, and to round out the inevitably distorted form by heeding your own experience to be gained in the second period already referred to—the period during which you are to be in engineering in subordinate positions in close contact with facts.

But as you gradually, by being successful, pass into the third period in which you again depend upon utilizing the brains of others, you will find that the facts you must deal with have not been known long, that they are not well organized, that they come to you through one man or through a short series of men only, and that, as a rule, the relations between the facts are but dimly perceived by the men from whom you get them. Under these conditions the facts and principles come to you highly colored and greatly distorted and but dimly outlined because of the peculiarities of the man, or the few men, through whom you get them. It becomes, therefore, of prime importance to you to understand that man, or those men. To be entirely successful you must study men.

An engineer does very little directly without the intervention of other men between him and his accomplishment, even when he is in minor, subordinate positions. Even the levelman is dependent on his rodman and recorder. The inspector on construction may see with his own eyes, but he produces changes only by operating through a foreman or perhaps a chain of several men, including the engineer to whom he reports, the contractor, the contractor's foreman, and finally the workmen. The draftsman may seem to be directly in contact with his work, but he really accomplishes something only as he succeeds by means of drawings in guiding the skilled workman whom perhaps he never sees. In each of even these simple cases the effectiveness of the engineer is conditioned in part on his accurate understanding of the thoughts and feelings of the men through whom he works.

As an engineer rises higher in the organization with which he works, his field of influence becomes larger, but the line of men through whom he works to produce material results also lengthens. He works to an increasing degree through other men and it is of increasing importance that he understands other men. Or, if he fails to know men he is apt to fail to rise.

If you are to succeed—to be valuable in the world—to know is not enough, you must make others to know.

As soon as you are well started in studying men you will find yourself studying the need and purpose of organization. For as soon as you fully realize what great differences there are in their principal characteristics, and even how widely the capabilities of a given man may vary at different stages of his life, you will realize why and how it is that a group of men working together as an organization may accomplish much more than the same

men could if they worked independently, as individuals.

A very common conception of organization is that it is an arbitrary arrangement by which orders are transmitted by various steps, through different groups of officials, from the man at the head of the organization to the many men who form the rank and file and do the actual work. Many graduates have shown that they believe that the way for a man in a high position to get a thing done is to order it done. Poor and inefficient administrators may do it that way. The successful administrators are men who act on the principle that their business is to administer unto those below them in the organization in three ways. First, by putting them into such places and under such conditions that they can do their best; second, by giving them orders necessary to show what is expected of them; and, third, by enlisting their wills, as well as their bodies and minds, in the work of the organization so that they will do their best. The first and third of these, the average graduate has never seriously thought of. He sees in the administrative officer the man who orders. The successful administrator finds his time so thoroughly filled with the first and third kinds of administration, with putting each man in the place and under the conditions most favorable to his effectiveness, and with enlisting in the service the will of the man, that orders fill but a small part of his horizon.

The men near the top in an organization normally do the most difficult work. Normally, they are the men who work most intensely and for the longest hours. In the great organization with which I am connected, the civil service of the United States, this is so commonly recognized that it calls forth no comment to see the rank and file leave at four-thirty and come at exactly nine, while others who are in responsible control of the organization work early, late and strenuously.

To attain to the highest success as an engineer you must not be the type of man who knows how to do things excellently, but cannot tell others how to do them—the man who gets knowledge abundantly, but can apply it only through his own fingers. Instead of devoting your energy simply to increasing your own output by fifty or even one hundred per cent., it is far better—you make yourself more useful to the world—by using your energy to increase the output of each of one hundred men by ten per cent. The world recognizes this by awarding the prizes to the administrators.

# Some Points About Series Transformers

H. S. BAKER

IT is commonly known, but not so commonly appreciated as it should be, that the secondaries of series transformers should be always either short circuited when there is current flowing in the primaries, or else connected so that the current delivered may not be constrained from its normal value or phase by the reaction of other series transformers. The bad effects of such constraint of the secondary flow of current are as follows:

A serious voltage rise occurs upon the whole series system fed by the transformers. This often results in someone getting a bad bump who touches the series wiring, and has in at least one instance resulted fatally. Although a voltmeter placed across the open secondary of the series transformer that produced the above fatality showed only 400 volts, yet a consideration of the case will show that while the "root mean square" voltage as shown on the meter was 400 the instantaneous voltage waves were probably over 1500 volts.

The voltage rise on opening the secondary series connections has in several instances been observed to break down insulation in instruments connected to series transformers and has been seen to strike an arc over one thirty-second inch and to draw an arc of over an inch when full load was on the transformers.

Instruments are given in the factory higher insulation tests on shunt circuits than on series circuits, but in practice more than otherwise are the series circuits given the greater insulation strain due to open circuited series connections.

The iron of series transformers is apt to run hot enough to destroy the insulation if the secondary is left open for a length of time with load on the primary. This is on account of the excessive saturation of the iron due to the prevention of the secondary ampere turns from neutralizing the effect of the primary ampere turns in magnetizing the iron.

The reasons for the excessively peaked voltage wave delivered by the open secondary of a heavily loaded series transformer are as follows:

When the secondary current is not allowed to flow and neutralize almost entirely the magnetizing effect of the primary current, then the whole full

load value of the primary current goes to magnetize the iron and the result is that the iron is strongly saturated. This saturation obtains over most of the time occupied by a half cycle, and in a very short time when the primary current is passing through its zero value, the whole flux reverses and grows to saturation in the opposite direction. During this short time the voltage wave climbs to its high peak and dies away again. This is the interval in which the man gets his "bump" and the instrument gets its insulation strain. A peaked wave shows only a low voltmeter reading compared to its maximum instantaneous value, and a voltmeter connected to the open secondary allows a little current to flow, thus receiving less than the true open circuit voltage of the series transformer.

Some cases of voltage rise have been observed as follows:

First: The secondary of two series transformers were erroneously connected in series and fed some meter circuits. The primaries being on different phases of the power circuit. Each transformer tried to deliver current in phase with its primary current, but both secondaries being in series, constrained the current to be alike in both coils. The result was, somewhat hot iron and a voltage rise.

Second: On a three-phase line there was a series transformer primary in each wire of line. The secondaries were connected in star, but one secondary was reversed. Each secondary feeds an ammeter, and the circuits after passing through the ammeters came together in a star. The instantaneous value of the current which the reversed transformer tried to deliver toward its ammeter was opposed by the resultant of the instantaneous currents fed from the other two transformers. The result was that two of the ammeters showed an incorrect reading, and the third showed zero. There was a voltage difference generated between the star point of the transformers and the star point of the meters. Upon connecting these two star points by a wire the three meters read correctly, and the flow of current in this star connector was twice that in one of the meters.

Third: When the reversed transformer in the above case was cor-

rected there was no flow of current in the star connector and it was removed. However, when a partial ground would occur on the line a spitting was reported to be heard in the meters. This can be explained by a voltage rise between the star points being generated due to the fact that the instantaneous algebraic sum of the primary currents in the series transformers did not add up to zero and hence the secondary currents tried to add up to a value other than zero, but on account of there being no star connector this excess current could not flow and hence the voltage rise was produced.

## Centrifugal Pump Trouble

W. WILSON

The recent experience of a manufacturer of centrifugal pumps with outfits consisting of a centrifugal pump connected to a shunt-wound, direct-current motor manufactured into a direct-connected unit, may be of interest as showing some of the peculiar phases of electric drive. The head against which the pump was to work called for a speed in the pump of about 1180 rev. per min. As the competition was severe the pump manufacturer purchased one of the cheaper motors in the market of 1200 rev. per min. The motor was sent to the pump shop for mounting, and the set having been tested was shipped to the purchaser.

The outfit was duly installed and connected up and current finally turned on. The attendant found that the pump did not pick up its load. He was sufficiently familiar with direct-current motors to know that by shifting his brushes a bit the speed could be raised above normal. He shifted them until the pump caught its load and started in to work successfully. Finding everything working satisfactorily he went about his duties in another part of the building but returned in one-half hour just in time to see his fuses blow out, but not before he caught by the sound that the set had been racing at unknown speed. He put in new fuses and jiggered the brushes back to the 1200 rev. per min. point, but as the indicator showed that the tank was full, he left the set without start-

ing it again. In twenty minutes he returned to find that more water was needed in the tank and accordingly started up the set. The motor now picked up its load at once although it had refused previously to do so at this point. He let it run a while, and making sure that everything was right, went away for about fifteen minutes. On returning he again found the pump racing and so he now moved the brushes down to about the normal 1100 rev. per min. point, when the speed, according to his ear, became all right again. After a five-minute run at this speed the tank became filled and he pulled the switch. In less than a quarter of an hour he received a call from the office to start the pump on account of low water, and forgetting where he had left his brushes started up on the 1100 rev. per min. speed. The motor picked up its load at once and continued without any trouble. The following morning when he tried to start on the 1100 rev. per min. point the motor would not pick up its load nor would it start on the 1200 rev. per min. point; it was only when he shoved the brushes to the 1300 rev. per min. point that he could start the pump. Intermittently all day long he would sometimes be able to pick up load on one speed or another.

This peculiar condition when reported to the pump manufacturer caused considerable speculation as to the cause, as the set had been tested before it left the shop. The trouble had every indication of being an electrical one and the motor manufacturer was called into consultation. He very quickly located the trouble and corrected it. In the first place, the set when first put up on their test floor was put to work against an artificial head supposed to be equivalent to the service conditions but probably not equal to it. When installed at the customer's work and first started the motor was cold, and 1200 rev. per min. would not quite pump water to the tank. The attendant having raised the speed to about 1300 rev. per min. obtained speed enough and delivery started. The motor carrying its full load quickly warmed up and the increased heat of the field-winding soon caused a higher resistance in the fields. This higher resistance weakened the field and increased the speed of the motor slightly. This change in speed caused the pump to increase its load as the square of the speed change, so that the slight excess of motor speed produced a relatively heavy pump overload. The motor now began to draw still more current followed by more heating and still higher speed, following this cycle until the fuses

finally blew out as the attendant first came into the room. With the brushes shifted back to the 1200 point, the set was started up the second time with the fields still hot, so that 1300 rev. per min. were obtained instead of 1200 rev. per min. The brushes after some time were shifted back to the 1100 rev. per min. point, where the load was thrown off. The set was started up the third time while the fields were still hot enough to give 1300 rev. per min. from the 1100 point. Of course the following morning the motor would not pick up its load at either the 1100 or 1200 points because the motor had cooled down over night.

A motor wound for 1300 rev. per min. with a compound winding adjusted to keep the speed change within two per cent. was substituted for the shunt motor and no further trouble resulted. Ordinarily a shunt-wound motor would not have changed in speed as much as this one did, but the motor manufacturer had put into his yokes an inferior iron, with the result that there was practically no regulation in the motor.

#### Commercial Day Program N. E. L. A. Convention, 1908

Thursday, May 21st, has been set aside by President Farrand as commercial day for the annual convention of the National Electric Light Association.

The committee, composed of C. W. Lee, J. Robert Crouse, John F. Gilchrist, George Williams, Howard K. Mohr and Frank B. Rae, Jr., has been busily engaged in preparing the program for the day. It is the purpose of the committee to have the papers which will be presented consume the least possible time; the major portion of the two sessions being devoted to discussion. The following is the program as outlined by the committee:

##### (1) Special Feature:

Relationship between the engineering and commercial departments by a prominent electrical engineer.

##### (2) Preparation for a Campaign:

- (a) Field work and other essentials,
- (b) Analysis of customers' accounts,
- (c) Proportion of lamp equivalents lost to lamps connected—showing percentage in cities of varied population.
- (d) Policy of handling complaints,
- (e) Policy of handling collections.

##### (3) The Contract Agent and the Representative:

- (a) The contract agent—his possibilities,
- (b) The district representative—his possibilities,
- (c) The special representative,
  1. The sign expert,
  2. The power expert,
  3. The woman representative.
- (d) Solicitors meetings—their objects.

##### (4) The Display Room:

- (a) Appointments and methods,
- (b) Value of special demonstrations,
- (c) Value of electrical and food show exhibits.

##### (5) Advertising:

- (a) What is being done?
- (b) Why?
- (c) Results.

##### (6) Publicity:

- (a) Methods to create proper public sentiment,
- (b) Dormant publicity opportunities of lighting companies.

##### (7) Creating Demands for Electricity:

- (a) The creative principle,
- (b) Notable examples,
- (c) Stereopticon talk upon outlines and sign lighting—showing progress in large and small cities.

##### (8) Evolution of New Business Building:

- (a) Examples of central stations that have continued methods during depression,
- (b) Strong plea for up-keep of commercial departments and advertising,
- (c) Opportunities for creating business along existing lines.

##### (9) The Electrical Contractor: Symposium:

- (a) What he is doing to assist in creating greater demands for electricity,
- (b) Specific examples.

##### (10) Co-operative Commercialism: J. Robert Crouse.

##### (11) Illuminating Engineering as a Commercial Factor: Illustrated. By V. R. Lansingh.

##### (12) Report of Committee on Solicitors' hand-book: Award of prizes offered by Co-operative Electrical Development Association.

Questions and Answers

Question.—I have to wire up a three-horse power, alternating-current motor which is not provided with any compensating starting device. Now the full load amperes of this motor are 10 per leg. The starting amperes, according to the bulletin, will be about 40. If I fuse my line switch for 10 amperes they will blow out every time I start. If I put in 40-ampere fuses I will have no protection against overload when the motor settles down to work.

Answer.—Wire according to the sketch herewith shown.

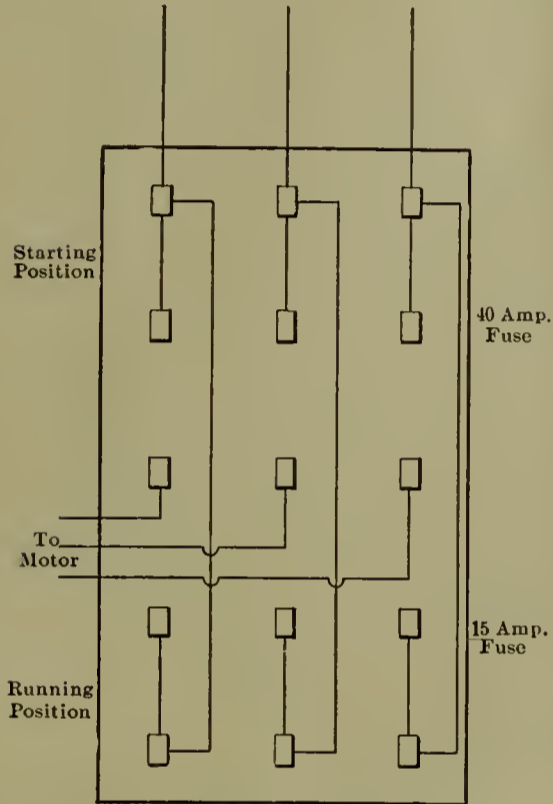

By this method the 15-ampere fuses will be cut out during starting, but cut into service when the motor has reached load speed and current is down to its running value.

Question.—Does not a slow-speed motor take less current through the meter than a high-speed one, because its speed is not so great and therefore would not require so much current to drive it as a high-speed motor?

Answer.—Both motors will take the same current through the meters. A motor does a certain amount of horse-power work and draws that amount of horse power of electrical energy through the meter. The unit of horse power is made up of two things, a pull measured in pounds and a distance through which that pull is exerted, measured in feet. A multiplication of these two gives foot-pounds of energy (one pound by one foot equals one foot-pound). If one motor be built with a pulling effect at the surface of its pulley equal to 10 lb., and we revolve this pulley through a distance of 3300 ft. a minute (approximately 1100 rev. per min.) we have a 1-h.p. motor. If, however, we had taken a motor having

30 lb. at the pulley and had revolved it through only 1100 ft. (or about 375 rev. per min.) we would still have a 1-h.p. motor. In both cases the foot-pounds were the same, and as the customer pays for the electrical equivalent of the foot-pounds (watts) his bills would be alike in both cases.

Question.—I have a number of belt drives to install where my changes in speeds will be all the way from 3-1 to 10-1. What is the limit of change between any two pulleys according to best belt-drive practice before there would begin to be too much slippage on the small pulley end due to the belt not having enough contact surface?

Answer.—Millwrights seldom install over a 6:1 reduction between pulleys unless the distance between centers is very great, that is, considerably over 15 ft. If obliged to make a 10-1 reduction you should belt motors to a countershaft and belt to drive shaft again, making two reductions. As an alternative you can purchase a motor carry an idler pulley which will keep the belt lapped over about two-thirds of the motor pulley. By using this drive you can belt directly from shaft to motor pulley on even a 10-1 reduction.

Question.—We are going to install a centrifugal pump driven by a direct-current motor. Should we purchase shunt or compound-wound machine?

Answer.—Buy a compound-wound motor so that the speed of the shaft may be as nearly as possible constant under all conditions. Read the article on another page telling of a peculiar pump trouble.

Question.—Will you please inform me through the valuable columns of your Journal the formula for finding the safe carrying capacity in amperes of rubber-covered wire?

Answer.—The formula is usually given as

$$I = \frac{d^2}{48}$$

where I is current in amperes and d is diameter in mils, or thousands of an inch. The values are given in the table:

B. & S. GAUGE		AMPERES
Solid.....	16-15	6
	14-13	12
	12-11	17
	10-9	24
	8-7	33
Strand.....	6	46
	5	54
	4	65
	3	76
	2	90
	1	107
	0	127
	00	150
	000	177
	0000	210

Electrolytic Copper Refining

A current of electricity passed between two electrodes of copper suspended in a solution of copper sulphate will dissolve copper from one electrode, carry it to the other electrode and deposit it thereon. This is the process by which about 400,000 tons of copper, more than one-half the raw copper production of the world, is refined. There are about a dozen electrolytic copper refineries in the United States, and these supply over 86 per cent. of the world's output of electrolytic copper.

Copper may be refined in less expensive ways where the raw copper does not contain gold and silver, but where these metals exist in the raw copper the electrolytic process is justified by the value of the by-products. Ulke has estimated that over 27,000,000 oz. of silver and 346,020 oz. of gold are recovered annually from the slimes of the American (U. S.) copper refineries. We are therefore largely indebted to the presence of the precious metals in copper ores for the pure copper so much used in the electrical industries.

The anodes of cast raw copper are prepared in casting machines, a modern example of which is the revolving furnace at the Tacoma refinery. This is constructed on the model of the black-ash revolving furnace used in the Le Blanc alkali industry, the anodes being cast by pouring the molten metal on a series of movable trays and molds. These anodes are cast with lugs, by which they are supported upon two bus bars running along each side of the vat.

The cathodes in the multiple process described below are thin sheets of pure copper obtained by electro-deposition in special vats. They are provided with devices to prevent buckling and are supported by hooks from rods running transversely across the vats.

The vats are of wood, lined with lead and supported on insulators, and therefore resemble the tanks used for station storage batteries. The number of electrodes in each vat is sometimes as great as 60 and the weight of anode metal per vat may now amount to 6½ tons.

The anodes and cathodes in each vat are generally connected respectively in parallel and the vats in series. This is known as the multiple or Thofern system, but another one known as the series or Hayden system is coming into use. In this system only the two end electrodes in each vat are connected to the current leads, and all the intermediate ones are supported on insulators. The current passes from one end of the vat

through the electrolyte and through the secondary electrodes, and while copper is dissolved from one face of these, it is deposited on the other face. The cathode faces have to be specially prepared in order that the deposited copper may be stripped off. This process eliminates the use of special cathode sheets and separates the electrodes of opposite voltage so as to reduce the risk of short circuits.

The current density varies from 13 to 40 amperes per square foot in different refineries. A high current density involves extra operating risks, but is desirable in order to obtain a quick turn-over of the copper.

The latest practice is to use high speed homopolar generators with taps for 125, 250, 375 and 500 volts, the voltage used depending on the number of vats to be connected. These generators offer the important advantage of having no commutator.

The charging and discharging of the vats are effected by traveling cranes.

The precious metals are not dissolved appreciably by the sulphuric acid radicle and therefore fall to the bottom of the vats as slime. A slight amount of silver which may go into solution is precipitated by hydrochloric acid in the electrolyte. The slime is removed from the vats

periodically and boiled in sulphuric acid to remove traces of copper and is separated from the copper sulphate by filtration. The mud is thoroughly washed, pressed into cakes, and the gold and silver extracted from the dried cake by metallurgical and chemical parting methods.

#### Electricity In Construction Work

Steel sheet piling has made a place for itself in construction work owing to its superiority over wooden sheet piling, but it has a very serious disadvantage, in that whenever it is necessary to cut such piling off at a desired level it is a very expensive piece of work to do by hand, even when the assistance of power-operated drills and hammers is available. In the construction of the foundations for an extension of the Hoffman House in New York, interlocking channel bar steel sheet piling was used, the sectional area of metal per lineal foot of piling being 14 sq. in. In cutting this off to level, using electric drills and cold chisels, the labor cost \$9 and the electricity \$13, making a total cost of \$22 per lineal foot. This was so expensive that it was decided to endeavor to burn the piling off by the use of an electric arc.

A connection was made to the lines

of the United Electric Light and Power Company, delivering single-phase 2500-volt current and four 20-kw. transformers were installed, connected in multiple to deliver current at 50 volts potential. One side of the circuit was grounded on the steel piles while the other was connected to a carbon electrode mounted on a long wooden handle. The electrode consisted of a carbon bar 12 in. long and  $1\frac{1}{4}$  by  $\frac{3}{4}$  in. clamped between two copper plates. A horizontal bar with a sliding suspender was provided to guide the electrode. The man operating this device was protected by an asbestos mask, large black goggles and gloves, so that no portion of his skin was exposed to the glare of the arc or its heat.

The operation of the device was very simple, it being only necessary to make a contact with the steel pile and form an arc, care being used to avoid breaking the arc after its formation. The arc consumed about 650 amperes at 50 volts potential and the cost of cutting off the piles by this method was \$1 per lineal foot. The foregoing data was supplied by the Thompson-Starrett Company, contractors for the building, and is of interest as illustrating the adaptability of electricity to one of the difficult problems met by contractors.

## Downward Illumination

THOSE who have been long in the lamp business will remember the familiar dark spot under the old Edison hair-pin filament. Actual test showed the downward distribution of this form of carbon filament to be about 2 c-p. on a 16-c-p. lamp. While the dim spot on the floor or table beneath the lamp was of course less objectionable than the broad black shadow of the gas fixture which it replaced, nevertheless the downward distribution of the filament was quite unsatisfactory. Some years later the idea was introduced of a double hair-pin filament, each part having about half the length of the first filament. This was the original Bryan Marsh double filament lamp. It gave 4 c-p. in downward intensity on a 16 c-p. lamp and was satisfactory progress. Following closely upon this development came the oval-anchored type of filament adopted by the General Electric Company which is the universal type of Edison lamp now in service. A 16-c-p. lamp using this filament shows 7.2 c-p. vertically downward. The light distribution curves corresponding to these various figures are shown in the accompany-

ing cut. The particular set of tests from which these curves and figures are taken was made in 1904 by the United States Bureau of Standards, Washington, D. C., under the supervision of S. W. Stratton, director of the Bureau.

The deficiency of the oval-anchored filament in downward illumination has, however, been sufficient to produce several types of lamps which surpass it in this respect.

The ordinary incandescent lamp is usually placed some feet above the point where light is desired; and except in the general illumination of public buildings, the strongest light is needed directly under the lamp or in the lower quarter circle of its distribution. Illustrations of this may be found in the lighting of machines, work benches, desks and counters. The use of a reflector would be unnecessary if the filament were arranged so as to have the largest amount of possible light in a general downward direction instead of in a sidewise direction. To appreciate the force of this point it is only necessary to hold an Edison lamp horizontally and then vertically, noting the great increase of light in the former posi-

tion. As a result of continued thought on this problem we have the double round coil used in the Columbia lamp, the Tipless Lamp Company's lamp and the Sunbeam reflector lamp. This filament shows 9.8 c-p. downward in a 16-c-p. lamp. Lastly come the Shelby double flattened coil filament showing 11.3 c-p. downward, the Sterling spiral showing 15.3 c-p., and the Wormley or so-called downward light lamp, showing a maximum intensity of 16 c-p. downward. In the downward light uniformity of horizontal distribution is somewhat sacrificed; the maximum horizontal intensity of light in this lamp being twice as great as the minimum. In most of the other types, the horizontal distribution is nearly uniform. Comparing all the lamps, however, on the basis of equal mean spherical candlepower, that is for a given total flux of light, the Wormley lamp shows much the greatest intensity of light in the quarter circle downward. In this respect the Sterling spiral filament is a close second.

Both of these types of lamps are rapidly gaining favor in sign work where the maximum light is needed through the end of the bulb. In this

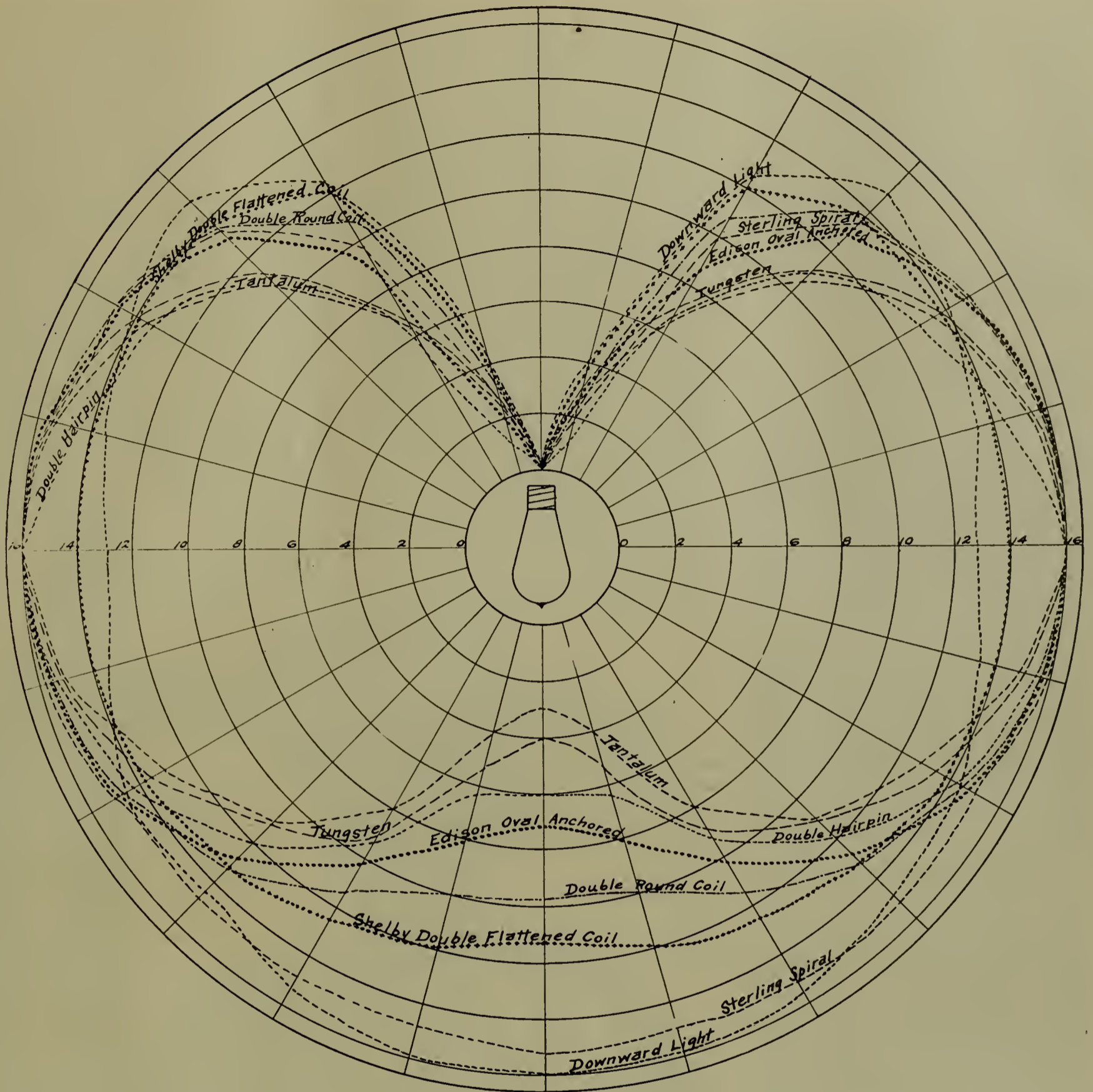

CHART SHOWING THE DISTRIBUTION OF LIGHT OF A NUMBER OF LAMPS SHOWING A LARGE AMOUNT OF DOWNWARD ILLUMINATION.

class of work a 2 c-p. downward successfully displaces a 4 c-p. oval-anchored filament lamp, having as much outward illumination with the same current consumption.

There is no commercial reason why one of the latter types should not displace the oval-anchored type entirely for car lighting. In cars where lights are placed vertically over the seats without reflectors, as in the Interborough and New York Central cars, a 16 c-p. downward light would throw twice as much light on the passengers' newspapers as a 16 c-p. Edison lamp; or on the other hand an 8 c-p. downward would give as much as a 16 c-p. Edison. With the Sterling or Shelby light the advantage

would be almost as great. In store lighting, too, the advantage of this class of lamps is evident not only in throwing light down upon the showcase and counter, but also diagonally upward upon shelves of goods. It is plain from a study of the distribution curves that such a lamp hung vertically over a counter will illuminate the shelves of goods displayed from ceiling to floor in a more nearly uniform manner than the oval-anchored filament. Rays of light proceeding in a horizontal direction travel the shortest distance to illuminate the objects upon which they fall. The intensity of the horizontal light from these lamps is less than that which is thrown in a diagonal direction and

which has to travel a greater distance to illuminate its field. In using an oval-anchored filament the most brilliant rays are given out sideways, and as its horizontal illumination has the shortest distance to travel, objects approximately in a horizontal plane are brilliantly illuminated and objects removed from a horizontal plane receive much less illumination. There are two reasons: first, the light has farther to travel from its source, and second, the intrinsic brilliancy in this direction is diminished very considerably.

While the various high efficiency lamps using metallic filaments are not destined soon to replace the carbon filament among general consumers, a

glance at their light distribution curves will be interesting. The same cut shows curves for bare tungsten and tantalum lamps in which the distribution is much poorer than for the standard carbon filament lamps. In fact, they are so unsuited for use as a bare illuminant that it is necessary to employ reflectors to change the distribution curve. Properly, the tungsten lamp may not be considered as an illuminant *per se*. It requires the combination of lamp and reflector to give the proper distribution of light.

#### Legal Notes

##### FALL OF STREET LAMP—BURDEN OF PROOF ON COMPANY.

Proof that an electric light lamp suspended over a street fell and injured a traveler because the rope holding it broke raised a presumption of negligence on the part of the light company, and the burden is on it to show the contrary. *Louisville Lighting Co. v Owens*. Court of Appeals of Kentucky. 105 Southwestern 435.

##### PRIVATE LIGHTING BY MUNICIPALITY.

A company which has obtained from a city a franchise to furnish light for its inhabitants cannot object to the grant of a similar right to some one else or to the furnishing light by the city itself to its citizens. *Crouch v. City of McKinney*. Court of Civil Appeals of Texas. 104 Southwestern 518.

##### LINEMAN INJURED BY FALL OF ROTTEN POLE.

A lineman, engaged with others in removing wires from poles, who was injured by the falling of a pole on which he was at work, caused by its being rotten beneath the sidewalk in which it was planted, cannot be held to have assumed the risk from such danger under the circumstances explained. *Munroe v. Fred T. Ley & Co.* U. S. Circuit Court of Appeals. 156 Federal 468.

##### SUPPLY OF ELECTRICITY BY CITY TO INDIVIDUALS.

Where a city owning an electric light plant has a surplus of electricity remaining after discharging its public duty, it may expend current funds to put that power in use so as to supply electricity to its citizens for private use. *Crouch v. City of McKinney*. Court of Civil Appeals of Texas. 104 Southwestern 518.

##### INJURY TO LINEMAN—QUESTION FOR JURY.

In an action by a lineman employed with others in removing electric light

wires from the poles on which they were strung to recover for an injury caused by the falling of a pole on which he was at work, it was shown that the cause of the injury was the negligent method of doing the work; that the act of negligence which was the immediate cause of the falling of the pole was done by a workman by direction of one of two men who were standing on the ground, and not working with their hands, but giving directions to the workmen. *Held*, that such evidence was sufficient to entitle plaintiff to go to the jury on the question whether or not such men were, or either of them was, "entrusted with and exercising superintendence and whose sole or principal duty was that of superintendence," so as to render the defendant, as employer, liable for his negligence under the Massachusetts employer's liability act (Rev. Laws Mass. c. 106, § 71). *Munroe v. Fred T. Ley & Co.* U. S. Circuit Court of Appeals. 156 Federal 468.

##### DAMAGES OF \$30,000 NOT EXCESSIVE FOR PERSONAL INJURY.

Where plaintiff, an electric lineman, was severely burned through defendant's negligence by a heavily charged electric wire, and suffered and would continue to suffer indescribable pain in consequence of the injury, a verdict of \$30,000, sustained by the trial court, will not be set aside on appeal as excessive. *Reeve v. Colusa Gas & Electric Co.* Supreme Court of California. 92 Pacific 89.

##### DUTY OF ELECTRIC CO. TO USE REASONABLE CARE.

An experienced electric lineman was not negligent, as a matter of law, in working near wires which he did not know were charged, without inquiry as to the current of electricity; it being the duty of the electric company to use reasonable care to so control and manage the operation of the system and the place where plaintiff was put to work that the wires should be free from dangerous currents under the company's control while the work was in progress, or to give plaintiff necessary warning and instructions to enable him to avoid the danger, in so far as it was reasonably possible and compatible with the nature of the work. *Reeve v. Colusa Gas & Electric Co.* Supreme Court of California. 92 Pacific 89.

##### LINEMAN EXCEEDING INSTRUCTIONS.

Plaintiff, an experienced electric lineman, was given a general order to assist in transferring a transformer from one pole to another. He had been informed that there was necessity for haste, and after he had attached the crossarm on the pole, ready to receive the transformer, he saw his fellow servants on the ground getting ready to throw to him the rope necessary to hoist the block and tackle to be used in raising the transformer to its place, and also saw the foreman take the cord containing the transformer and run it up under the pole. *Held*, that plaintiff was not negligent in exceeding his instructions in proceeding at once to the top of the pole to attach the pulley to hoist the transformer without special instructions, which he was attempting to do when he was burned by a heavily charged wire; plaintiff being ignorant of the fact that his foreman intended to delay the raising of the transformer until after the lunch hour. *Reeve v. Colusa Gas & Electric Co.* Supreme Court of California. 92 Pacific 89.

##### PROPER FASTENING OF ELECTRIC LAMP TO CEILING.

In an action for an injury to a clerk in a store, caused by the fall of a lamp maintained by defendant electric light company, and hung by a hook screwed through a thin board, it was improper to exclude a question, asked a carpenter testifying for plaintiff, as to where hooks are usually placed when attached to ceilings; the obvious intention of the question being to show that the hook should have been screwed into a joist. *Fish v. Waverly Electric Light & Power Co.* Court of Appeals of New York. 82 Northeastern 150.

##### INJUNCTION TO RESTRAIN CITY FROM SELLING ELECTRICITY TO PRIVATE PERSONS.

One seeking to restrain a city owning and operating an electric light plant to light its streets from selling electricity to private persons for lighting must show that the city did not sufficiently light its streets, and that it was financially able to extend its system for lighting its streets, since the city, after discharging to the best of its ability its duty of lighting the streets, could sell its surplus power to private citizens for lighting. *Crouch v. City of McKinney*. Court of Civil Appeals of Texas. 104 Southwestern 518.



# New Type of High-Speed Steam Engine

## The American-Ball Angle Compound

A NEW and interesting type of high-speed engine is described in the following article for the first time in this paper.

This engine marks a distinct epoch in the development of practical steam engines, and is the culminating work of a life-time spent in developing and perfecting high-speed engines.

This latest engine is the joint production of Mr. F. H. Ball, the well-known engine designer, and his son, Mr. F. C. Ball.

In the early days of high-speed engines there was great similarity in the valve gears of all makes, but in later years there has been a divergence in the line of development followed by

engines and the greater liability of interrupting service more than offsets the small gain in efficiency that may be realized from a multiplication of the valves and valve mechanism, and that where high efficiency is desired, a much better plan is to use a compound engine of simple design because it is vastly more economical of steam than any simple engine even with the most complicated valve gear.

Mr. Ball and his son have consistently held to this view and have sought to attain the extreme of simplicity and fewness of parts. The well-known duplex-compound engine is in this line of development, and now this newest engine, called the angle-compound, is another step in the same direction.

The general plan of combining a

York City, but engineers do not seem to have appreciated the many desirable features of this arrangement for high-speed engines of the single-valve type.

It is well understood that with reciprocating engines the question of counterbalance becomes increasingly important and serious as the speed is increased.

A very erroneous idea is somewhat prevalent to the effect that reciprocating engines may be counterbalanced so that the thrusts of inertia are neutralized. Nothing could be further from the truth, because a counterweight attached to the heel of a crank merely transfers the unbalanced thrust from the plane of the reciprocating parts into a plane at right angles to it. Thus in a locomotive the counterweight in the driving wheel, which is absolutely necessary to keep the engine from "nosing" violently at high speeds, simply transfers the unbalanced thrust to a vertical plane. Recent experiments with a locomotive testing equipment have shown that at high speeds this vertical thrust becomes so great that when the counterweight passes over the shaft, the wheels, with the weight of the engine on them, are actually lifted clear of the track. This seems incredible, but has been abundantly demonstrated.

The casual observer of high-speed engines does not understand that with a horizontal engine the inertia thrust of the reciprocating parts which will rock a foundation badly will, if transferred into a vertical plane, be easily resisted by the same foundation. The engine then has no rocking tendency and, therefore, seems to be balanced.

The usual practice of engine designers is to counterbalance to the extent of transferring the largest part of the horizontal thrust to a vertical plane, leaving only such an amount of horizontal thrust as will be safely resisted by the usual foundation.

Keeping this in mind, it is evident that by combining a horizontal and vertical engine on the same crank pin, the total amount of horizontal thrust may be neutralized by counterbalance; and when the counterweight is in a vertical plane, it is opposed by the reciprocating parts of the vertical engine so that at four points of the stroke a perfect balance is realized, and between these four points there is no position of the crank when any appreciable unbalanced condition is found.

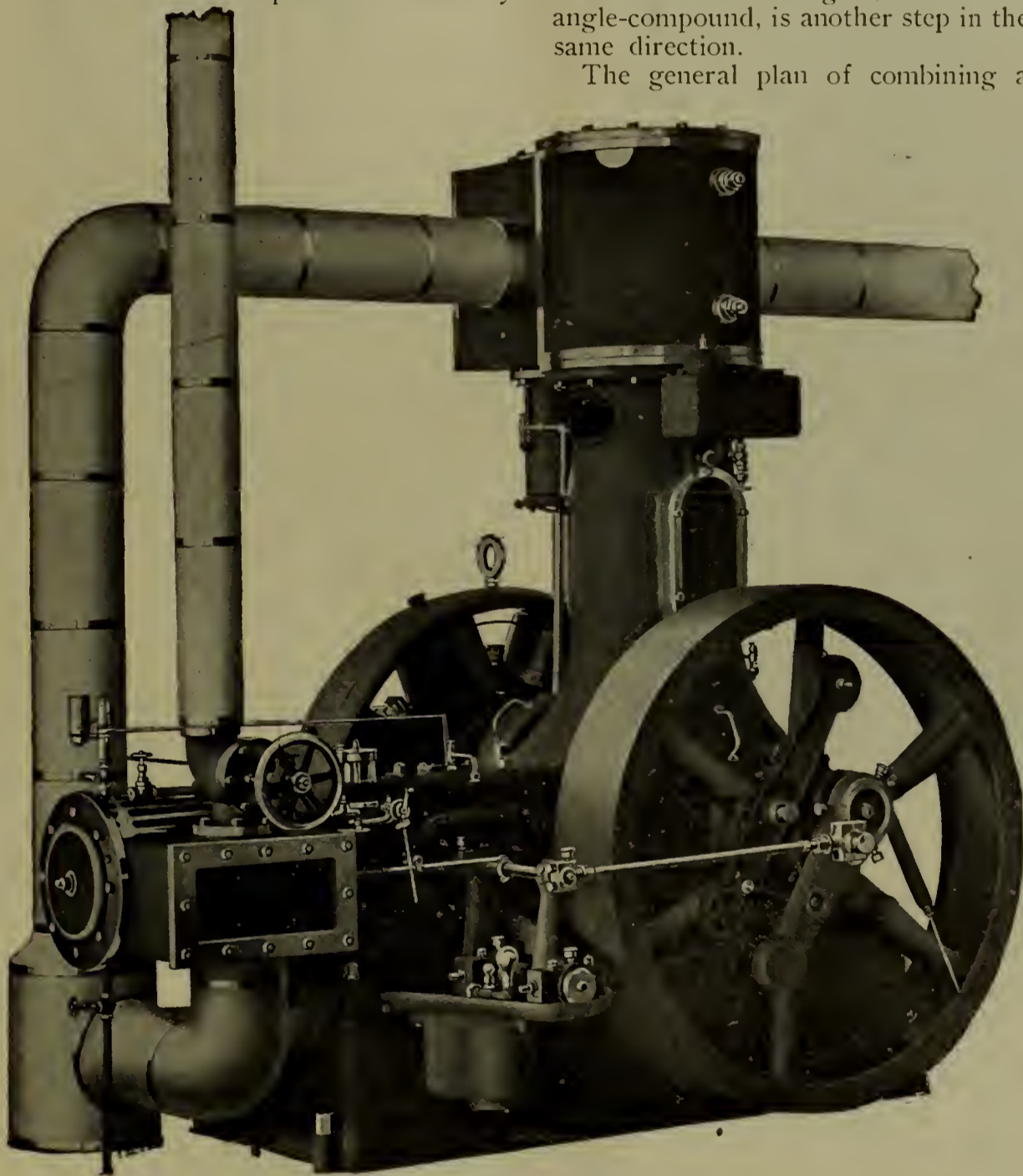

AMERICAN-BALL ANGLE COMPOUND ENGINE.

designers of this class of engines. Some have sought a refinement of efficiency by the use of complicated valve gear. Others have claimed that the increased cost of maintenance of complicated valve gear on high-speed

horizontal engine and a vertical engine so that both shall work on the same crank pin is not new. There are conspicuous examples of this general type in the giant engines installed in the traction power-houses of New

In the angle-compound engine here-with illustrated, the conditions for perfect balance are brought about by making the low-pressure piston a very light, conically-shaped steel structure of about the same weight as the ordinary cast iron piston in the high-pressure cylinder. The low-pressure engine is made the vertical engine because it is thought desirable to have the larger piston rest on the piston rod rather than to drag in a horizontal cylinder.

It will be seen by reference to the several views of the engine that the high-pressure valve is driven by the usual valve gear and shaft governor, and the low pressure by an eccentric which is enclosed in an oil-tight cas-

water drip from mingling with the oil of the circulating system. The water drip from all these stuffing boxes is carried off by concealed piping so that the engine is never untidy in appearance.

A new departure has been made in this engine in the arrangement of the crosshead and guides, which are of the bored type. It will be noticed that the crosshead is a single piece without the usual adjusting shoes, while the guides are made adjustable. These guides are carried in bored seats, and a projection from the back of the guide fits between the supports so as to resist and thrust. One of the guides is secured to the support by screws, and is only adjustable by

the crank at each revolution instead of two large ones would seem to have every justification. They have recently installed in their own power plant one of these new engines of 160 h.p., 11-in. stroke, running about 300 rev. per min., direct connected to one of their generators. This engine has no special foundation, except the concrete floor of the building, and has not a single foundation bolt. The writer stood a new full length pencil on its end on the horizontal cylinder head and then on the vertical cylinder, and there was not vibration enough to disturb the delicate balance of the pencil even with a fluctuating load on the engine. It is apparent, also, that this is the only form of reciprocating engine that can really be counterbalanced, and it is therefore better suited to high speed than any other type of reciprocating engine.

It is evident, also, that the floor space of this engine is very small. Since a horizontal engine carries a vertical engine of the same power, the power for a given floor space is, therefore, doubled. This also reduced the cost of foundation to the same extent, so that practically half the foundation is saved; besides, the perfect balancing of the engine makes the foundation problem such a very simple one, that where concrete floors are used no further foundation is ordinarily required, thus saving the entire cost of foundation.

For large powers these engines, combined in pairs with the generator or belt-wheel between them, make an exceedingly compact unit. In these combinations the engines are used as double-compounds when run non-condensing, or where condensing water is available, as four-cylinder triple-expansion engines. In the latter case one horizontal engine is the high pressure, the other horizontal the intermediate pressure and the two vertical engines combined are the low pressure, thus giving a large area of low-pressure piston without using any pistons of very large diameter.

Since the normal speed of an engine of this kind is high, the cost of the generator and the amount of floor space are both greatly reduced.

#### Large Electrical Machines Built at West Allis Works, Allis-Chalmers Company

Several months ago steps were taken to stock and equip two of the great machine shop units at the West Allis works of Allis-Chalmers Company, known as shops 5 and 6, for the building of large electrical machines, particularly those intended for direct connection to the various forms of prime movers which constitute a

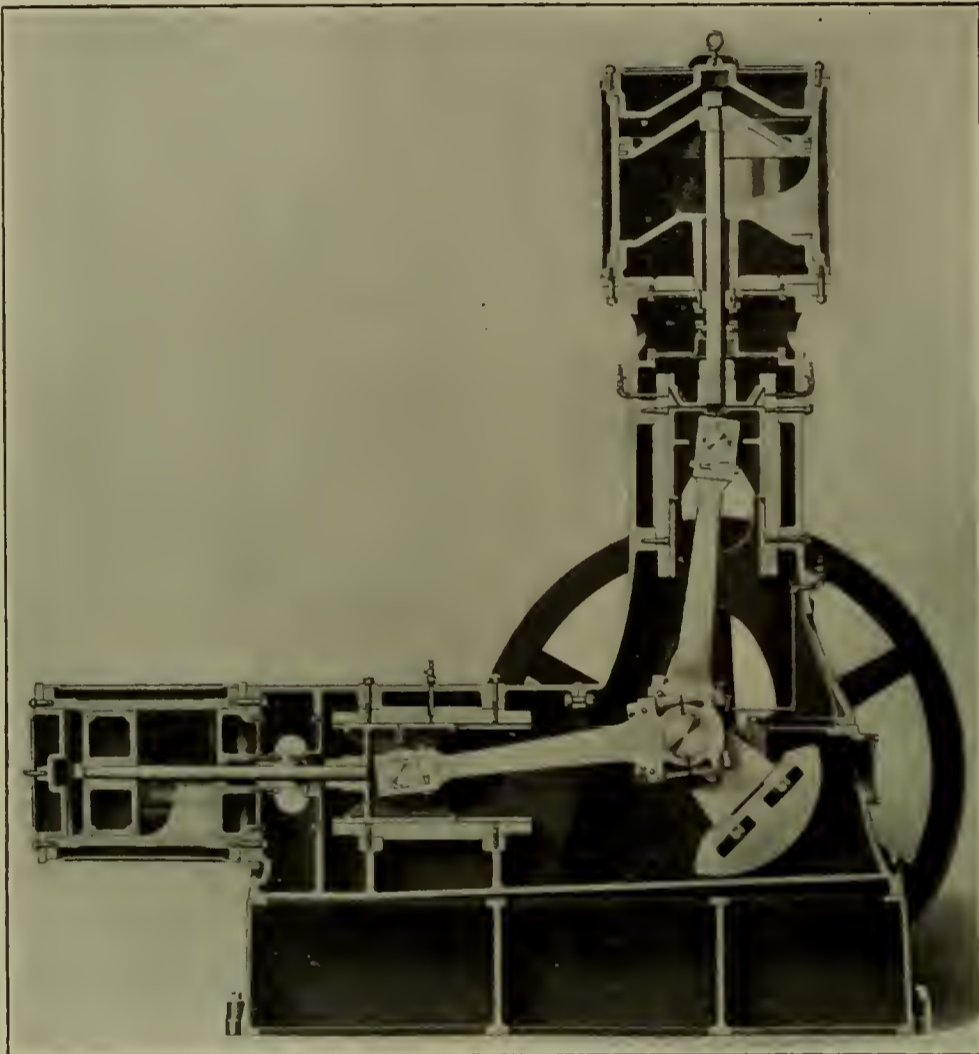

CROSS-SECTION OF AMERICAN-BALL ANGLE COMPOUND ENGINE.

ing and connected with the oil-circulating system of the engine. From this eccentric a rod drives direct to the low-pressure valve stem, which is guided by a cross-head carried in guides as shown, and this cross-head and guides are also included in the oil-circulating system of the engine. The oil-circulating system is similar to that used on the American-Ball engines, with which engineers are familiar, except that the oil is pumped directly to the gravity storage tank on the low-pressure frame, which is kept constantly overflowing by the supply delivered to it from the pump.

A double stuffing box on the valve stem and bulk heads and stuffing boxes on both piston rods prevent the

means of shims, but the other has a pair of screws at each support to provide for delicate adjustments, and the guide is securely held against these adjusting screws by a bolt that locks the adjustment securely when set up.

It is, of course, understood that the crank pin is double the usual length, and that the connecting rods are placed side by side on this double length pin. This completes the general description of this new and interesting engine.

The builders' claim that this type of engine runs more smoothly and with much less strain and shock than any other form of high-speed engine because of its perfect balance, and because it has four small impulses on

large part of the product of this great company.

Heretofore the large electric generators for driving by gas engine, steam turbine, water-wheel or Corliss engine have been built exclusively at the company's works in Cincinnati, Ohio. The construction of a part of these large machines in Milwaukee gives much needed room for the manufacture of motors, transformers and small generators at Cincinnati and does away with the former necessity of shipping heavy engine shafts to the electrical works to be fitted and keyed to the rotors of engine type generators. On the other hand, the West Allis works are better equipped, through large experience in the building of big equipments, to handle the heavy parts.

To indicate the type of work which has already been turned out at West Allis, shipment was recently made of two 2000-kw., 6600-volt, 25-cycle, 3-phase alternators which were sent to the Homestead works of the Carnegie Steel Company. These alternators are for direct connection to 42 by 54 in. Allis-Chalmers twin tandem gas engines, also products of the West Allis works.

A third alternator was recently shipped to the central furnaces of the American Steel and Wire Company. This machine was a 1000-kw., 13,200-volt, 25-cycle, 3-phase unit, designed for direct connection to a 34-in. by 42-in. Allis-Chalmers gas engine. These three generators were the first to be completed and shipped from the new shops, and others, including a 6500-kw. unit, will follow in rapid succession during the next few weeks.

#### Electrical Equipment of Hydro-Electric Plant

The General Electric Company is furnishing complete electrical equipment for a hydro-electric plant in Nagoya, Japan, a city with a population of about 250,000, situated some 300 miles from Yokohama. The main generating station will be built at Yawozo, on the Naiko River, where power will be generated at 6600 volts by four three-phase, 2500-kw., 60-cycle, 360 rev. per min. water-wheel-driven generators. The generator voltages will be stepped up to the line voltage of 60,000 volts by 12 water-cooled transformers of 1000-kw. capacity each, and transmitted 30 miles to the main substation just outside of the city of Nagoya. Here the line voltage is to be stepped down to 11,000 volts by nine water-cooled transformers of 1350-kw. capacity each, and transmitted underground to the distributing station through triple-conductor, lead-armored cables, the city ordinances prohibiting an

overhead transmission of over 2500 volts.

In the central distributing station the voltage will be stepped down to 3400 volts by nine water-cooled transformers of 1350-kw. capacity each, at which potential it is to be distributed throughout the city by both overhead and underground cables.

It is interesting to note that from the nearest railway station the entire power apparatus for the Yawozo station will have to be transported on specially constructed wagons driven by oxen.

The Naiko River is normally 40 ft. in depth, but in the rainy season the river often rises to 40 and 70 ft. above low water mark. This rising characteristic of the river will necessitate the building of a specially designed dam to take care of the high water.

#### New Madeline Furnace of the Inland Steel Co., Indiana Harbor, Ind.

Since blowing in the new Madeline blast furnace at Indiana Harbor last August, the Inland Steel Company has produced its own pig-iron for use in steel making, instead of buying the iron from outside, as was formerly the custom. The new furnace has a nominal capacity of 400 tons of pig-iron per day, and the equipment of the plant auxiliary to the furnace, as well as the facilities for handling the blowing engines, power equipment, etc., are all of the most approved standard design and latest construction.

The new plant is located alongside of the company's steel plant, and a portion of the power generated in the newly installed power station is transmitted to it for use in operating various machinery. The works have a protected harbor 300 feet wide for receiving raw material, a good dock 1000 feet long and plenty of Lake Michigan water for cooling purposes.

Ore is taken directly from lake boats by means of electrically-driven hoists and carriers and deposited in storage piles or bins. Scale cars on motor-driven trucks handle ore between the bins and the furnace. The furnace proper is 85 ft. high, with a diameter below the hearth top of 20½ ft. As far as possible the furnace filling and distribution are done automatically.

The open-hearth plant is located across the tracks of the Lake Shore & Michigan Southern Railway, and a concrete-lined hot metal tunnel, built under the railroad tracks, communicates with it.

Coke is stored in a 60-ft. bin, and six bins 91 ft. 9 in. long hold limestone and ore. The cast house is 108

ft. long, with an additional length of 104 ft. for claw mixing and ladle-drying purposes.

The boiler plant, situated directly back of the furnace, comprises eight 500-h.p. Sterling boilers, each with individual stacks. There are two pairs of Allis-Chalmers Vertical Long Crosshead Furnace Blowing Engines installed, whose steam cylinders are 44 in. and 84 in. in diameter and air cylinders 84 in. and 84 in. in diameter, with 60-in. stroke. These engines are designed to operate either singly or in compound condensing pairs. The steam may pass through a reducing valve when the low pressure side is run singly.

The power plant is further equipped with three Allis-Chalmers cross compound Corliss engines, each direct-connected to a 550-kw. direct-current generator of the same build. The engines are uniform in type, having cylinders 20 in. and 42 in. by 42 in. stroke. Power is transmitted from the power-house to a distributing station at the steel mills, a distance of about 1200 ft., by conducting cables supported on steel towers, to the property line of the blast furnace plant and from this point by underground conduit beneath the intervening tracks.

In addition to the engines already enumerated there is installed in this plant an Allis-Chalmers horizontal cross compound Reynolds-Corliss pumping engine used for hydraulic transmission in the mills, operating lifts, stands and other handling apparatus. The water end of this unit has a capacity of 800 gal. of water per minute against a working pressure of 500 lbs. per square inch under severe continuous service. Mr. Arthur G. McKee, engineer, of Cleveland, designed and superintended the erection of the plant.

#### Western Portable Instruments

A low-priced line of portable alternating-current instruments has lately been placed on the market by the Weston Electrical Instrument Company, Newark, N. J. The voltmeters range from 75 to 750 volts, direct reading, ammeters from 1 to 300 amperes, direct reading, and the milliammeters range from 75 to 750 milliamperes.

These instruments have no discernible working error, practically no temperature correction, are independent of the frequency of the circuit and possess closely uniform scales. One of the strongest points of the high-grade Weston instruments is the dead-beat character of their indications, and in this respect the low-priced instruments are fully as good.

### Remarkable Performance of an Induction Motor

The general sturdiness and endurance of the induction motor under adverse conditions is proverbial, and the following incident serves to illustrate the reason for their universal popularity.

A five-horse power, 440-volt, squirrel-cage General Electric induction motor was belt-connected to a centrifugal pump in the quarry of the G. H. Perry Co., Sioux Falls, S. Dak., the capacity of the pump being 158 gal. per min.—lifting same about 45 ft. The motor was operated continuously during the rainy season, and was often allowed to run without attention during the night.

One Sunday morning an operative noticed that the quarry pit was full of water, the motor being partly submerged. The necessity of clearing the pit of water being evident, the current was turned on. To the surprise of all, the motor came up to speed and carried the load until the pit was clear, apparently none the worse for its prolonged bath. On examining the motor the next day, that portion of the paper pulley which had been under water was found to be softened and considerably warped out of shape. This motor gave excellent service until two months later, at which time it was completely destroyed in a fire which consumed several of the company's buildings.

### All Together for a Bigger, Brighter and Busier Marion

The Marion Light & Heating Co., Marion, Ind., has recently put into successful operation one of the best new business schemes evolved in many years. Here it is:

The Marion *News Tribune*, the important daily of that thriving city, appeared one morning as an electrical edition with a special electrical supplement of eight pages. The front page showed a large night view of Washington Street, the main business street of the city, and gave an account of a banquet of the employees of the lighting company under a special head.

The leading business houses were featured in electric signs—free advertising, and the industrial plants utilizing electricity exclusively were also played up splendidly in half-tones and in interviews of their proprietors setting forth the advantages of the electric drive.

The local paper has probably found this special edition profitable, as it contains a large number of extra advertisements of the electrical and allied interests.

The slogan of the company—"a bigger, brighter and busier Marion"—

has aroused the citizens of that city to largely co-operate with the earnest efforts of the lighting company to give Marion a greater commercial importance.

We are of the opinion that this clever stroke of business boosting hardly cost the local lighting company more than the distribution of a monthly flyer. It did, however, cost some thought on the part of S. H. Smith, the energetic superintendent of the company, and E. T. Hollingsworth, manager of its new business department. They are to be congratulated.

### General Electric Earns \$9,800,000

The report of the General Electric Co. for the year ended January 31, 1908, will be made public some time in May. The statement will show a gross business of approximately \$70,000,000, which compares with \$60,071,883 in the preceding fiscal year.

Had it not been for the depression in the latter part of 1907, the company would have made an even better showing.

The ratio of profits to business billed was about 14 per cent. or about the same as in the preceding year, which will bring the net earnings on the \$70,000,000 of business billed up to approximately \$9,800,000, an increase of about \$1,400,000 as compared with the fiscal year ended Jan. 31, 1907.

The following table gives the amount of business billed, profits applicable to dividends and the percentage of profits to gross of the General Electric Co. over a series of years, the figures for the fiscal year ended January 31, 1908, being estimated:

Year ended January 31st:

	AMOUNT BILLED	PROFITS APPLICABLE TO DIVIDENDS	PER CENT. PROFITS TO GROSS
1908.....	*\$70,000,000	*\$9,800,000	14%
1907.....	60,071,883	8,427,842	14%
1906.....	43,146,902	7,319,161	17%
1905.....	39,231,328	6,719,546	17%
1904.....	41,699,617	7,789,370	19%
1903.....	36,685,598	10,232,839	28%

\* Approximated.

The above table shows a remarkable expansion in the business of the General Electric Co., but the decrease in the ratio of profits to gross cannot be regarded as a favorable development.

It would appear that while the gross business of the company has shown an extraordinary increase, there has accompanied it an increase in operating costs which have operated against a proportionate expansion in net profits.

One explanation advanced for this showing is the high prices for copper and other material entering into the manufacture of electrical equipment,

competition and higher operating costs in general over the last few years.

It is well known that the business of the General Electric Co. this year will not be as large as in the preceding fiscal year and, naturally, earnings are expected to show a falling off. However, the General Electric Co. will have the advantage of lower priced copper, etc., in the current year, and a reduction in operating costs would not be at all surprising.

The current depression in business did not begin materially to affect the shipments of the General Electric Co. until January of this year. In that month it is understood that shipments aggregated about \$4,400,000, or at the rate of \$53,000,000 a year, as compared with \$70,000,000 for the full fiscal year ended January 31, 1908.

President Coffin in his last annual report called attention to the fact that the sales billed for the first two months of the fiscal year ended January 31, 1908, were more than 50% greater than in the corresponding period of the preceding year. Also that the total stock issued and subscribed aggregated \$65,134,300, and that there had been authorized but not issued or subscribed \$14,819,866, making a total outstanding and authorized capital of \$80,000,000.

Shortly after the annual report was made public, the General Electric directors voted to offer stockholders approximately \$13,000,000 five per cent. convertible bonds at par. These bonds have all been sold. In view of the heavy falling off in business, no General Electric financing is to be expected this year.

The General Electric Co. is now operating about 50% of its normal capacity, and its consumption of copper is about one-third of normal.

The company has been buying copper, but its purchases for some time past have been of a hand-to-mouth character.—*Wall Street Journal*.

### Joints

One of our esteemed contemporaries furnishes the following information. The extract is given in full:

Bad joints may be considered as the unpardonable sin among electrical men, especially on circuits carrying small volume currents. Even with care, however, they will sometimes develop, as there are so many causes that may produce them. Every binding screw, every fuse or cut-out, every connection of whatever nature may be considered as a source of bad joints trouble and treated accordingly. Needless to say, every line joint should be soldered or sleeved.—*Electrical Record*.

# THE ELECTRICAL AGE

Volume XXXIX. Number 4.  
\$1.00 a year; 15 cents a copy

New York, April, 1908

The Electrical Age Co.  
New York and London

ESTABLISHED 1883

Published monthly by The Electrical Age Co., 45 E. 42d Street, New York.

J. H. SMITH, Pres. C. A. HOPE, Sec. and Treas.

JOHN HAYS SMITH, Editor.

Telephone No. 6498 33th. Private branch exchange connecting all departments.

Cable Address—Revolvable, New York.

## SUBSCRIPTION RATES

United States and Mexico, \$1.00; Canada, \$1.50. To Other Countries, \$2.50

## NOTICE TO ADVERTISERS

Insertion of new advertisements or changes of copy cannot be guaranteed for the following issue if received later than the 15th of each month.

## LONDON OFFICES

Business and Editorial Departments, 33 Bedford Street  
Strand, W. C.

London Telephone, Post Office, 3807 Central. Private branch exchange. London Cable  
Address—Revolvable, London.

All remittances to London Office should be crossed London and County Banking Company.

## BRANCH OFFICES AND AGENCIES

Subscriptions may be sent to the following branch offices or agencies, where they will receive the same careful attention as at the home office in New York:

124, Queen St., Melbourne  
359, George St., Sydney  
61, Main St., Yokohama  
23, Esplanada Rd., Bombay

33, Loop St., Cape Town  
Unter den Linden, 5, Berlin  
Nevsky Prospect, St. Petersburg  
31, bis rue de Fauburg Montmartre, Paris

General Agents for United States and Canada: The American News Company

## Electricity From Coal

There is periodically brought before the public, puffed and put on the market, a new form of electric battery which, it is claimed, is about to effect a revolution in our methods of power generation. Most of these are so obviously worthless that the investing public pays little or no attention to them, but occasionally a battery of sufficient novelty to attract the attention of technical men is devised and a great future predicted for it. A battery which consumes coal or carbon is sure to attract the attention of the public, and the claim that it will halve, or even reduce by 90 per cent., the cost of power is listened to with more or less credulity. It will not be amiss, then, to consider what claim these carbon-consuming batteries have on the attention of the public.

When a pound of coal is carefully burned it gives out sufficient heat to raise the temperature of about 8500 lb. of water 1 degree cent. This, as demonstrated by Joule, Rowland and others, is equivalent to raising a weight of 1,000,000 lb. through a height of 12 ft., or 12,000 lb. through a height of 1000 ft. Therefore, if all the energy of coal were available, a supply of one pound of coal per hour would give six horse-power. Now, a very excellent steam engine and boiler give only about one-half horse-power for every pound of coal consumed per hour. Hence we get but one-half horse-power where we should get six. This extraordinary wastefulness is inherent to all heat engines. A good modern steam engine utilizes nearly 90 per cent. of the energy available from the steam that enters it, about 10 per cent. being lost in friction and other incidental losses.

In an average boiler, from every pound of coal consumed per hour, about 1.5 h-p. goes up the chimney in hot gases; about 0.15 h-p. remains in the hot and partly consumed ashes;

about 0.3 h-p. is radiated from the boiler, and about 0.3 h-p. goes off in unburned gases, leaving 3.75 h-p. to evaporate the water. Of this 3.75 h-p., a part is wasted by radiation, condensation and friction in the steam pipes and engine. This amounts to about 0.1 h-p. Hence, if all the energy of the steam were available, the engine should give about 3.65 h-p., but as a matter of fact it will only give one-half of one. In short, the engine will only convert into mechanical work about one-seventh of the energy of the steam, or about one-twelfth of the energy in the coal.

The action of all heat engines depends on the flow of heat from one body to another, and it is not possible to extract all the heat energy from a body without removing all of its heat. All the heat cannot be removed from a substance unless its temperature is brought down to 273° cent. below zero. The efficiency of a heat engine is directly proportional to the difference between the temperatures of the incoming and outgoing fluid. Thus we see that good efficiency cannot be expected from any steam engine unless the temperature of the exhaust is very low and that of the incoming steam very high. That is the reason why superheated steam is attracting so much attention. Even with a perfect engine exhausting at the absolute zero of temperature (−273° cent.), only about one-half of the energy of the coal would be available, owing to boiler losses. It thus appears that the boiler is so inefficient and the engine so defective in principle as a machine for producing mechanical energy that there is great need for a more efficient way of utilizing coal.

As a contrast to the wasteful engine, consider the electric battery. Here conditions are reversed. Instead of only one-twelfth of the energy of the fuel appearing as useful work, eleven-twelfths are used. The effi-

ciency of an electric battery may be 90 to 95 per cent. Unfortunately the battery of to-day cannot compete with the dynamos and steam engine on account of the great cost of the fuel it consumes. This fuel is almost invariably metallic zinc and its cost is quite prohibitive. In the electric battery the stored chemical energy of the fuel is converted directly into electric energy with only a few secondary and unimportant losses. With a battery of low resistance these losses are very slight. The ideal way of obtaining power is to cause some fuel of the value of coal to combine rapidly in an electric cell with some cheap oxidizer like air or water. How to do this is a problem that scientists and inventors have been occupied on for over half a century. The limited degree of success attained is evident from the fact that as a motive power the steam engine still holds undisputed sway.

The electric battery is primarily a chemical apparatus, so that to understand the principle of the battery it is necessary to grasp the chemical principles underlying its action. When any chemical action takes place there is either an evolution or an absorption of kinetic energy. This energy usually appears or disappears in the form of heat. The combination of substances having a mutual affinity gives rise to kinetic energy, while the decomposition of a compound requires the expenditure of energy. These two cases have good mechanical analogues. Two substances having a mutual chemical affinity may be likened to the earth and some water at an elevation. These have a mutual attraction. The water tends to fall to the earth's surface, and in falling gives up the energy it possessed in virtue of its position. This energy ordinarily goes to waste in heating the water, as in the falls and whirlpools of Niagara, but it may be usefully employed in turning

a, waterwheel and so supply power to factories. In the same way chemical action usually goes to waste as heat, but there is an apparatus analogous to the waterwheel which enables the liberated energy to be collected and used for practical purposes. This apparatus is the electric battery, or voltaic cell. An electric battery is an apparatus which enables the energy evolved by the combination of substances having chemical affinity to be collected as electrical energy instead of as heat. Analogous to the decomposition of a chemical compound is the separation or raising of water from the earth. This requires an expenditure of energy through a pump. Analogous to the pump is an electroplating bath, in which the metal is, at the expense of outside energy, forcibly separated from its compound and deposited on a foreign body. If carbon be caused to combine with oxygen there is an evolution of heat, while a considerable amount of energy is required to decompose carbon dioxide into carbon and oxygen. The combustion of one pound of coal will raise the temperature of 8500 lb. of water 1 degree cent., but the combustion of one pound of pure carbon will only raise the temperature of 8080 lb. of water one degree. A carbon-consuming battery would work more economically if it consumed carbon in the form of coke than if it consumed coal, because of the value of the gas and coal tar obtainable by distillation.

The combination of one pound of carbon with  $2\frac{2}{3}$  lb. of oxygen to form  $3\frac{2}{3}$  lb. of carbon dioxide is attended with the evolution of 8080 calories. If this heat is used to work a steam engine most of it will go to waste. If the evolved energy instead of appearing in the form of heat could be made to appear as electrical energy, we should have an ideal generator. Now, there is no way known in which carbon can be made to combine directly with oxygen so as to give rise to electrical energy. All voltaic cells that we know of require a liquid to attack the zinc, carbon, or whatever fuel may be used. Thus in order to make carbon and oxygen combine we must make the carbon take oxygen from a liquid compound containing that element. In order to make oxygen combine with carbon it must be separated from its compound, but in the case of many oxides a greater amount of energy is required to decompose the oxide in order to liberate the oxygen than is produced by the combination of this oxygen with the carbon. The chemical action in such a battery therefore would not only give rise to no evolution of energy, but would actually have to absorb energy in or-

der to take place at all. An example of such a battery is one using molten litharge or oxide of lead, where, in order to consume one pound of carbon, 803 calories would have to be supplied. The oxides which give rise to evolution of energy are those of antimony, arsenic, bismuth, bromine, chlorine, copper, gold, hydrogen, iodine, mercury, nitrogen, palladium, platinum, selenium, silver, sulphur, tellurium, thallium and some very rare elements. Of these metals some are not found in nature and cost much to make, others give rise to so little energy as to be negligible and others are volatilized at a temperature below that at which they will attack carbon. The only ones left as worth considering are the oxides of copper, nitrogen and sulphur.

In the case of copper oxide,  $\text{Cu O}$ , one pound of carbon requires 13 lb. of oxide to effect complete combustion, and although the heat produced by the union of carbon and oxygen is 8080 calories, the decomposition of the copper oxide requires 6321 calories. The difference between these sums is 1759 calories, and represents the energy liberated by the reaction. This is only about 22 per cent. of the total heat available from the combination of carbon and oxygen.

If copper oxide occurred commonly in nature this process might be useful, owing to the reduction of the oxide into metallic copper. Unfortunately copper oxide does not occur commonly in nature and is too expensive to make this practicable.

Sulphur dioxide is a gas at ordinary temperatures and pressures, and sulphur trioxide exists only in combination. An oxide of nitrogen exists in nature in the nitrates, as, for example, in saltpeter. The energy available from this is about 88 per cent. of that obtained by direct combustion in oxygen. Notwithstanding this high efficiency, the cost is prohibitive on account of the high price of saltpeter. The oxides of hydrogen have no effect on carbon. It thus appears that a voltaic cell in which carbon is consumed by an oxygen compound has no great future before it.

Consider, now, the combination of carbon with other elements. There is a series of compounds of carbon known as hydrocarbons. There is a great number of such compounds, but they cannot be produced by the direct action of hydrogen on carbon at ordinary temperatures. Whichever of these many compounds be considered, the energy liberated by the combination of hydrogen and carbon never exceeds one-fifth of that required to

produce the hydrogen by decomposing water. As water is our cheapest source of hydrogen, a hydrocarbon cell seems out of the question. The liquid hydrocarbon, dipropylene, is produced by the combination of one pound of carbon with one-fifth pound of hydrogen, the energy evolved being 814 calories. Now to obtain one-fifth pound of hydrogen, 1.6 lb. of water have to be decomposed, and this requires the expenditure of 5840 calories. What is true of dipropylene applies in various degrees to all the hydrocarbons.

There is no other combination which carbon enters into which gives rise to the evolution of one-fifth of the energy evolved when it combines with oxygen. Combined with sulphur, carbon forms carbon disulphide, and with nitrogen it forms cyanogen, the most deadly poison known. Very little energy is evolved by either of these reactions, or by the combination of carbon with the metals.

It thus seems that there is *no known* way of acting on carbon so as to liberate sufficient energy to compete with our present wasteful method. It hence follows that an economical carbon-consuming cell must be the result of an entirely new discovery.

There can be no doubt that the solution of the problem of devising an economical voltaic cell for consuming carbon rests as much with the organic chemist and physiologist as with the inorganic chemist. It seems less probable that the problem will be solved by trying to consume carbon directly than by trying to consume one of its compounds. Needless to state, this reaction must not require any heat to produce it, nor must it give rise to any appreciable amount of heat, and either the compound acted on must be very cheap or the compound produced must be valuable and marketable in practically unlimited quantities. Thus, if the product of combustion were acetylene or gasolene, a chemically inefficient reaction might be economical from a commercial point of view. The same is true if the products of combustion were easily converted into substances of commercial value, such as illuminating gas.

Many carbon cells have been devised which are not voltaic cells, but heat engines. It is quite possible that an electric heat engine—that is, an apparatus converting the energy of heat into electrical energy without the intervention of chemical action—may be made more economical than the present boiler and steam engine. This increased economy might be due to the absence of boiler losses and to the increased efficiency of the engine due to the higher temperature at which it

might be worked, but it must be remembered that all heat engines working within moderate ranges of temperature are intrinsically inefficient. With such a thermo pile, as it is called, the efficiency might be double that of our present heat engine, but it could never be very great.

It thus seems that there are serious limitations to the problem of utilizing all the energy of carbon or coal, but if in spite of these difficulties a really cheap source of energy should be invented, there will be as great a revolution in our industries as attended the invention of the steam engine.

#### The Delmar Short-Circuit Indicator

The difficulty of distinguishing a short circuit from a legitimate load has been a troublesome matter ever since the advent of heavy traction. A short circuit taking one thousand amperes would cause enormous damage, but on a modern traction system where a starting train takes several thousand amperes, the station circuit breakers have to be set so high that they do not open unless the overload is greatly in excess of the latter amount.

Hence it is not uncommon to hear of persistent short circuits entirely unknown to the station attendants, but involving thousands of dollars damage. This condition of affairs need no longer exist, thanks to the ingenious device described by Mr. Del Mar in this issue. The device is unpatented, and being endorsed by the New York Central Railroad as eminently satisfactory, should obtain extensive use wherever large feeders are employed.

The application of the system to third rails, although not yet tried, appears excellent. In the event of a train being derailed a long way from a substation, the short circuit current might not be sufficient to open the circuit breakers, but might set fire to the wreckage and cause serious loss of life. The possibility of this could be entirely obviated by the use of a short circuit indicating wire run along the third rail. If this system had been in use in the Paris Metropolitan system the terrible accident of August, 1903, could not have happened.

#### New Patent Laws in Britain

Hitherto the patent laws of the United Kingdom have been quite similar to our own, requiring merely a nominal fee, no taxes, and placing no obligation on the patentee to work his patent within the term of its life. With the passage of the Patent and Designs Act, 1907, effective January 1, 1908, the situation of the American

inventor taking out a British patent is greatly altered. He is now required to work his patent within four years and to make payments during its life, aggregating £155 (\$754.50). On the application for the provisional protection, the patentee is feed £1 with a fee of £3 on filing the complete specification and a further fee of £1 at the granting of the patent. At the end of four years from the date of patent, he may pay £50, and at the end of eight years further, £100; or beginning at the fourth year, he may make annual payments of £10 each, continuing until the eighth year, when the payment becomes £15, and £20 after the 10th year. A patent shall cease if the patentee fails to pay the prescribed fees within the prescribed times.

At any time not less than four years after the date of a patent, any person may apply to the Controller for revocation of the patent on the ground that the patented article is manufactured and carried on exclusively or mainly outside of the United Kingdom, and if this be established, on inquiry, the patent will be revoked. There are sundry limitations and privileges arising after various contingencies. The act is retroactive and will apply to all patents taken out in 1904.

The far-reaching effect of the new patent laws can hardly be measured at the present time, but it can safely be said that ultimately it will compel a large number of German and American manufacturers to build plants in England to hold their trade, as otherwise their patents will be revoked and British manufacturers will seize them. It will be interesting to see how the clause providing for the revocation of a patent upon an article manufactured mainly outside of the United Kingdom will work out when the courts come to take the matter in hand.

#### The Lighting of the Institute Library

In the last issue of THE ELECTRIC AGE we had something to say about the bad lighting of the library in the United Engineering Building. What was said of the lighting is indubitably true. It appears, however, that the lighting plans of the consulting engineer were not properly followed out, and the faulty lighting cannot therefore be imputed to them properly. The room is amply wired for the placing of sufficient lights and only some tardiness or indecision on the part of the proper committee has kept the library in its miserably lighted condition during the past year.

At the time of building a great number of floor and ceiling outlets were installed, both in the center of the library floor and in the center of the

alcoves, so that from six to twelve lights could readily be installed on each table. None of the fixtures has been installed, as it is understood that the Building Committee is undecided as to how the library would be finally arranged.

Two circuits have been run to each alcove for special outlets for lighting around the book-cases, but they have not yet been put in use. Unquestionably this part of the illumination should be remedied at once and a complete outfit of lamps should be installed on the reading-tables.

#### A Half Decade of Steam Turbine

We publish at another page the first authentic figures on steam turbine sales covering a period of about five years elapsing since the commercial exploitation of the steam turbine in this country. The aggregate kilowatts of Curtis turbines is 1,073,695, as against 640,700 kw. of Westinghouse turbines. Definite figures are not furnished us by the Allis-Chalmers Co., the only other important manufacturing company, but we should estimate their sales at under 200,000 kw. They have come into the field later than the other two.

A greater capacity of steam turbines of the vertical type has been sold than of both types of horizontal turbine, though it is not to be inferred from this statement that engineers generally show preference for the vertical type.

The collaborator of the Westinghouse figures has seen fit to omit the exact number of machines in each classification, but since this figure was necessary to get the average kilowatt which is given in the table, it is just as certainly easy to approximate the number by the inverse calculation. We make it 525, approximately. The number of vertical machines sold is 1096, or about twice as many. The Allis-Chalmers Co. has probably sold about 200 turbines. All counted, then there are about 1800 machines sold, and about 1500 in service.

The General Electric Co. has sold 243 turbines for industrial and miscellaneous purposes and the Westinghouse Company has sold about 235, as closely as we can reckon from the figures they give out. It would appear, therefore, that the turbine business has been about evenly apportioned in the industrial field. This shows pretty clearly that engineers have been about evenly divided in their opinion of the merit of the respective types.

The total kilowatts sold is about 1,800,000 kw., which represents, at current prices, an investment of about \$80,000,000 in this type of prime mover.

# Central Station Distributing System

## Secondary Distribution

H. B. GEAR and P. F. WILLIAMS

Commonwealth Edison Co., Chicago

IN the early stages of the introduction of alternating-current systems, the use of 52 to 55 volt secondary circuits was advocated by some engineers because of the superior life of incandescent lamps of these voltages. Such a voltage was not permissible in direct-current work because of the excessive amount of copper required, but was quite feasible in alternating-current systems because of the possibility of locating transformers close to the consumers' premises. At this voltage, however, it was not possible to supply more consumers from one transformer than could be reached from the pole on which the transformer was placed without an excessive use of copper. The result was a system in which a large number of small transformers were required, which consumed an excessive amount of energy in their cores and required the operation of extra generating capacity during the light load period to supply their large leakage currents.

As soon as such a distributing system attained such size that these items became too expensive a remedy was sought. The higher voltage lamp having been improved, 110 volt secondaries were introduced and the 55 volt consumers were gradually changed over to 110 volts. The use of the higher voltage increased the range of distribution so that a single 110 volt transformer was installed to replace several 55 volt transformers, with a saving in the amount of capacity required and a very great saving in the core losses and leakage currents.

Later, the availability of the Edison three-wire system for general secondary distribution increased the range of such lines by permitting the use of 110-220 volt mains, with 110 volt lamps. With this system it is possible to supply consumers economically within a radius of 400 to 600 feet from the transformer. This increases the number of consumers which can be carried from a single transformer and thereby reduces the capacity required per kilowatt connected. This is due to the fact that different consumers take their maximum demands at different times and the resulting maximum demand on the transformer therefore never equals the sum of the maximums of the individual consumers.

This system of secondary distribution is the one most generally used in American practice as it is the simplest and most economical for lighting work.

A system of secondary mains passes through three general stages of development in expanding from a small to a large system.

1.—A period in which scattered transformers supply isolated secondary mains not interconnected with other transformers.

2.—A period in which the mains from adjacent transformers grow together along principal thoroughfares where they may be connected to each other but intersecting few other secondary mains of importance.

3.—A final stage in which secondary mains are required on nearly all streets and are therefore joined into a network.

The first period is that found in residence and other outlying territory not fully built up. When a new consumer is to be connected in such a territory the problem is—Shall a transformer be installed or the nearest secondary main extended to the premises? The installation of a transformer involves an investment and an operating expense, due to its core loss. The extension of the secondary main also involves an investment in conductors and perhaps an increase in the capacity of an existing transformer. The cost of the two alternative plans being ascertained the one selected should be that which involves the least annual cost for interest, depreciation and operation. For instance, assume that service is required for a new consumer, for a load of one kilowatt, at a point where there is no secondary main available. Assume that if a separate transformer is installed the investment will be about \$30.00 and that if the nearest secondary main is extended the expenditure will amount to \$40.00. How shall service be given?

If the \$30.00 investment is made there will be fixed charges at the rate of 15 per cent., amounting to \$4.50 per annum. There will also be an operating expense, due to the core loss of a one kilowatt transformer of about 30 watts 8760 hr. per year, or 263 kw-hr. At one cent per kilowatt-hour,

this amounts to \$2.63 and the total annual cost is \$7.13.

Were the \$40 expended for a secondary main the fixed charges at the rate of 12 per cent. are \$4.80 and no operating expense is added unless it be required to increase the capacity of the transformer then installed. If it is necessary that one kilowatt be added to the capacity of the existing transformer the expenditure would be increased about \$8.00, adding a fixed charge of \$1.20 and an operating expense of about 10 watts or 87 kw-hr. per year, costing 87 cents. The cost per year under this plan is therefore \$4.80 in case the existing transformer can take the added load without change, or \$6.87 if it cannot. In this case it would therefore be preferable to extend the secondary rather than to install a separate transformer.

There is little occasion in this period of development to connect secondary mains in multiple. Where the mains have been extended until they meet each other it is usually preferable not to interconnect them, as the blowing of the fuse of either transformer shifts the load to the other and overloading it blows its fuse also; and transformers are so far apart that they cannot share each other's load to any appreciable extent in case of an overload on either of them.

The second period of development is reached when consumers become so closely situated that it is necessary to provide a secondary main along the entire length of a thoroughfare. This condition is usually first met along business streets and boulevards, and results in a long secondary main fed at intervals by transformers, but intersected by few other secondary mains of importance. When such a main has been established, it is the problem of the engineer to determine how far apart transformers should be located and what size of conductor should be used.

The density of the load varies in different parts of the street and there are large blocks of load at particular points which make the problem a perplexing one at best. A general solution is usually not possible, owing to the widely varying local conditions. However, a determination may be made which will serve to indicate the approximate limits within which the



most economical arrangement of transformers and wire will lie, and from which some general principles of value may be deduced.

Assuming that an overhead three-wire 115-230 volt secondary main

transformers is 3000 watts from the assumed values in the table above. This goes on 24 hr. a day, 365 days a year or 8760 hr. and therefore amounts to  $3 \times 8760 = 26,280$  kw-hr. At one cent this will cost \$262.80, or

In like manner the calculation is made for the other spacings of transformers at this load density and for the other densities of 100 kw. and 150 kw. per 1000 ft. Calculations are also made for a four-wire three-phase secondary operating at 115-200 volts, at a density of 150 kw. per 1000 ft. for purposes of comparison.

In case of water power the value of core loss should not be included and in large steam plants its value would be less than one cent per kilowatt in many cases.

Table 1 shows the results of the calculation for overhead lines and Table 2 for underground cables. The cable calculations are based on the use of single conductor paper insulated cable, having  $\frac{4}{32}$  in. insulation and an equal thickness of lead sheathing, with copper at 16 cents and lead at five cents per pound.

The curves in Fig. 3 show the variation of the various elements composing the annual cost with a load of 50 kw. per 1000 ft. overhead.

Fig. 4 shows the variation in annual cost on overhead lines at the three load densities assumed, together with the calculations for a three-phase secondary at 150 kw. per 1000 ft.

Fig. 5 shows the same for underground lines.

It is at once apparent from the curves in Fig. 4 that the minimum annual cost with overhead lines occurs with a spacing of about 500 ft. be-

6000 ft. in length is uniformly loaded at intervals of 100 ft., what will be the best size of wire and proper spacing of transformers?

The wire will be calculated to give two per cent. regulation from the transformers to a point midway between.

The value of transformers and wire with different spacings will be calculated for each of three load densities. Interest is taken at five per cent., depreciation on wire at seven per cent. and on transformers at 10 per cent. The cost of energy at one cent per kilowatt-hour and the cost of weather-proof wire at 15 cents per pound. The cost of transformers and their iron losses are assumed as follows:

Size K. W.	10	15	20	25	30	40
Watts, Iron Loss	110	150	175	20	230	260
Cost, Dollars	100	135	175	210	240	280

Size, K. W.	50	60	75	90	100
Watts, Iron Loss	300	330	380	430	450
Cost, Dollars	320	360	420	480	520

Calculations are made for load densities of 50 kw., 100 kw. and 150 kw. per 1000 ft. of line.

For instance, in the case of a load of 50 kw. per 1000 ft., a spacing of transformers 300 ft. apart would require 20 15-kw. transformers for the run of 6000 feet. It is found that No. 6 B. & S. will give two per cent. regulation in the secondary wire at full load. The iron loss of 20 15-kw.

\$263.00. The value of transformers is  $20 \times 135 = \$2700.00$ , and the fixed charges are \$405.00, at 15 per cent. per year. The value of 18,000 feet, 1980 lb., of No. 6 weather-proof at

15 cents per lb. is \$297.00 and the fixed charges at 12 per cent. are \$36.00 approximately. The total annual cost is therefore \$263.00, plus \$405.00, plus \$36.00, or \$704.00.

OVERHEAD

Size of Wire	Size & No. of Transf.	Iron Loss, Wtts	Distance between Transf.	Value of Transf.	15% on Transf.	Value of Wire	12% on Wire	Value of Core Loss at 1c	Total Cost
50 K.W. per 1000 Feet									
6	20-15	3000	300'	\$2700.	\$ 405.	\$300.	\$ 36.	\$ 263.	\$704.
2	12-25	2400	500'	2520.	378.	675.	81.	210.	669.
0	10-30	2300	600'	2400.	360.	1098.	129.	201.	690.
300	6-50	1800	1000'	1950.0	292.5	3150.	379.	157.	828.
100 K. W. per 1000 Feet									
4	20-30	4600	300'	4800.	720.	442.	53.	402.	1175.
0	15-40	3900	400'	4200.	630.	1098.	130.	340.	1100.
2/0	12-50	3600	500'	3900.	585.	1335.	160.	314.	1059.
4/0	10-60	3500	600'	3600.	540.	1207.	246.	305.	1091.
150 K.W. per 1000 Feet									
2	20-45	5600	300'	6000.	900.	675.	81.	490.	1441.
2/0	15-60	4950	400'	5400.	810.	1335.	160.	430.	1400.
4/0	12-75	4560	500'	5040.	756.	1207.	246.	392.	1394.
300	10-90	4300	600'	4800.	720.	3150.	410.	345.	1475.
150 K. W. per 1000 Feet (3-phase, 4-wire)									
4	60-15	9000	300'	8100.	1215.	590.	71.	788.	2074.
0	45-20	7900	400'	7900.	1185.	1464.	175.	691.	2051.
2/0	36-25	7200	500'	7560.	1134.	1791.	215.	631.	1980.
4/0	30-30	6900	600'	7200.	1080.	2760.	387.	605.	2072.

TABLE I.

UNDERGROUND

Size of Cable	Size & No. of Transf.	Iron Loss, Wtts	Distance apart	Value of Transf.	15% on Transf.	Value of Cable	15% on Cable	Value of Core Loss	Total Cost
50 K.W. per 1000 Feet									
6	20-15	3000	300'	\$2700.	\$ 405.	\$1710	\$256.	\$263.	\$ 924.
2	12-25	2400	500'	2520.	378.	2340	350.	210.	938.
0	10-30	2300	600'	2400.	360.	3330	500.	201.	1061.
300	6-50	1800	1000'	1950.	293.	7000	1050.	157.	1500.
100 K.W. per 1000 Feet									
6	30-20	5250	200'	6250.	787.	1710	256.	460.	1503.
4	20-30	4600	300'	4800.	720.	1980	297.	402.	1419.
0	15-40	3900	400'	4200.	630.	3330	500.	340.	1470.
2/0	12-50	3600	500'	3900.	585.	3850	575.	314.	1474.
4/0	10-60	3500	600'	3600.	540.	5200	780.	305.	1625.
150 K.W. per 1000 Feet									
4	30-30	6900	200'	7200.	1080.	1980	297.	602.	1979.
2	20-45	5600	300'	6000.	900.	2340	350.	490.	1740.
2/0	15-60	4950	400'	5400.	810.	3850	575.	430.	1815.
4/0	12-75	4560	500'	5040.	756.	5200	780.	392.	1928.
300	30-30	4300	600'	4800.	720.	7000	1050.	376.	2146.
150 K. W. per 1000 Feet (3-phase, 4-wire)									
6	90-10	9900	200'	9000.	1350.	2280	342.	865.	2457.
4	60-15	9000	300'	8100.	1215.	2640	395.	788.	2398.
0	45-20	7900	400'	7900.	1185.	4450	667.	691.	2543.
2/0	36-25	7200	500'	7560.	1134.	5150	770.	631.	2535.
4/0	30-30	6900	600'	7200.	1080.	6950	1060.	605.	2745.

TABLE II.

tween transformers, whether the load is 50 kw. or 150 kw. per 1000 ft. With underground lines the most economical spacing is about 300 ft. between transformers.

It is also evident from the shape of the curves of annual cost that the percentage of variation is small when other spacing than the most economical is considered. For instance, in the case of a load of 100 kw. per 1000 ft. overhead, a spacing of 300 ft. increases the annual cost but 11 per cent. over the most economical spacing of 500 ft. and an increase in the spacing results similarly. In view of this condition it is possible to allow some flexibility in spacings in order to take advantage of other considerations. For instance, the susceptibility of transformers to lightning and similar disturbances makes it desirable to work toward the longer spacings and a lesser number of transformers. The curves indicate that this can be done if desired without seriously affecting the economy. Again, it is usually desirable in building extensive secondary mains to anticipate an increase in load, by erecting a larger conductor than is required for immediate needs. This may be done and the spacing of transformers gradually lessened as the load increases. The cost will be slightly excessive at first, but decreases until a spacing of about 500 ft. is reached and then increases as spacings are further lessened.

Further growth must then be provided for by the replacement of the overloaded portions of the main by conductors of a larger size.

The entire foregoing discussion is based on an assumption that the load is evenly distributed along the line throughout its length.

Unfortunately such is usually not the case in practice. It is usual to find a portion of a secondary main heavily loaded and other portions lightly loaded owing to differences in the character of the neighborhood through which it passes. At intervals a large store, church or other consumers of electricity may throw heavy loads upon the line.

It is therefore necessary in practice to locate transformers as closely as possible to such large consumers' premises and design the main between them to carry the scattered consumers whose load is approximately evenly distributed. An extended secondary main may therefore be made up of several sizes of wire at different points with transformers having various spacings, depending upon the load density in the vicinity.

The design of the various portions of such a secondary main is therefore likely to be difficult unless the general theory outlined in the foregoing is taken into consideration, and intelligently applied.

The network is the last step in the development of a system of secondary

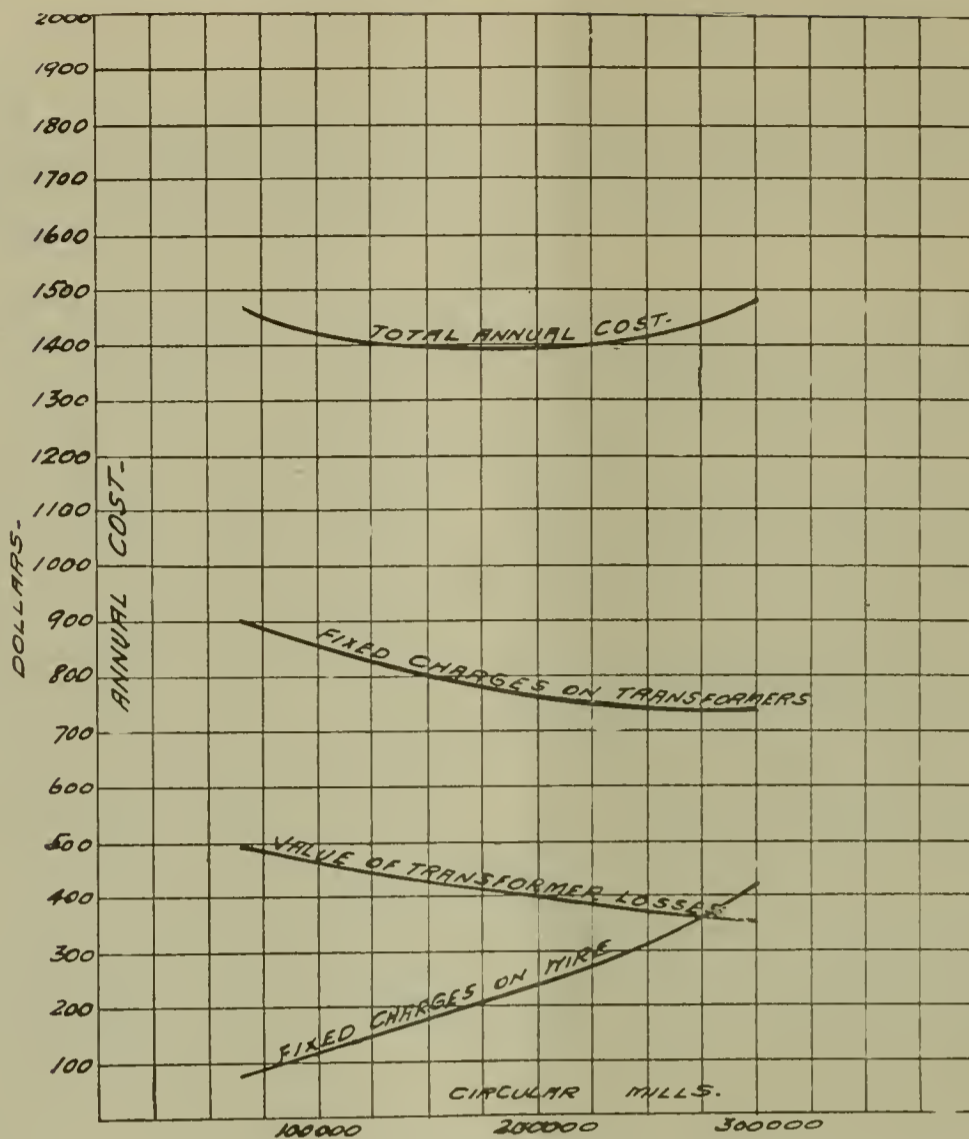

FIG. 3.

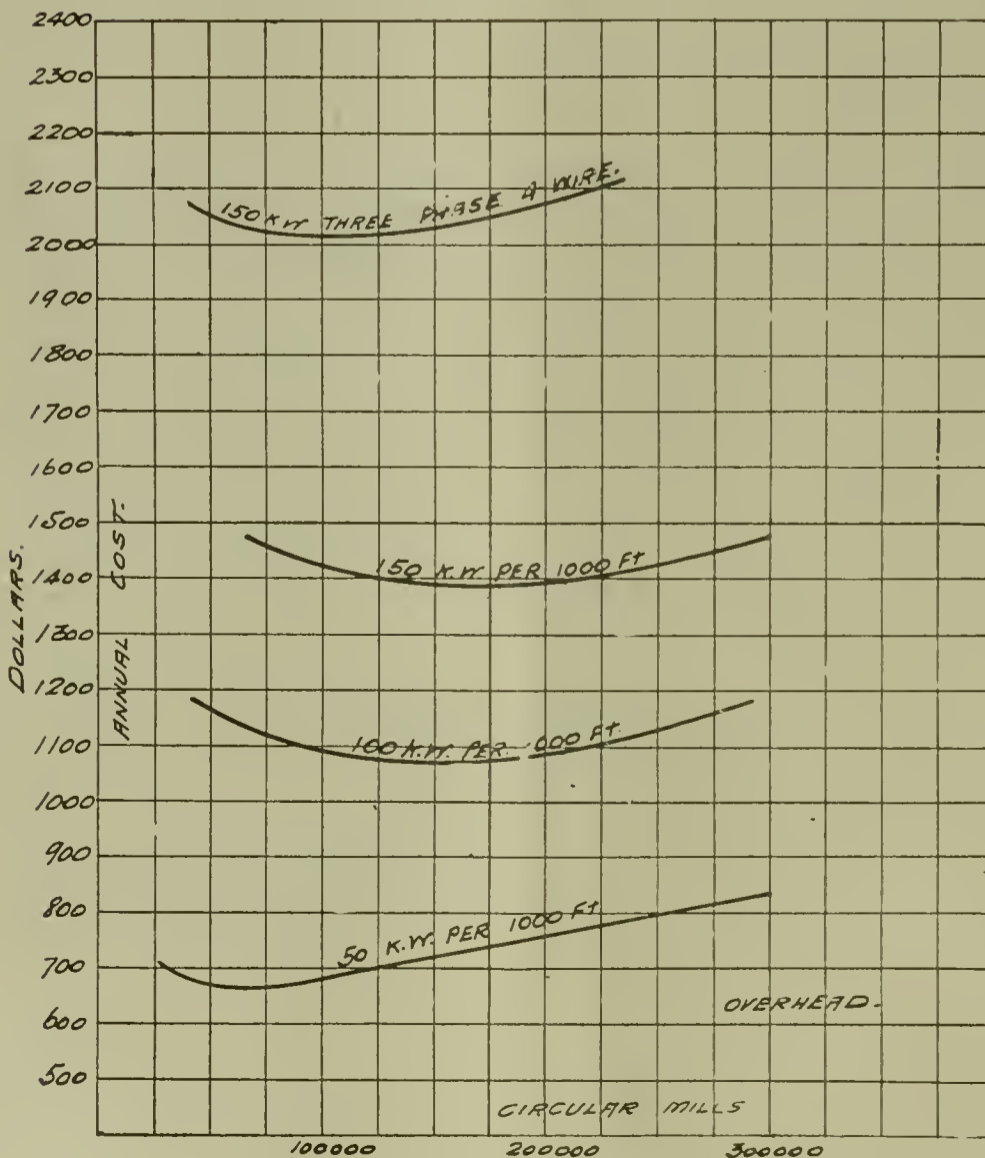

FIG. 4.

mains. It consists of a number of mains running at angles so that they cross each other and may be interconnected at all intersecting points.

Transformers are located at points of intersection where they deliver current in all directions with the best economy of copper. The transformers thus maintain the full feeder end pressure at all junction points where they are placed, as the primary mains are so short that there is no appreciable drop in them. This is an advantage over a direct-current network where each feeder usually is connected to the network in only one or two places and the mains must have greater capacity in order to maintain an even pressure throughout.

Large networks are usually underground since this form of construction is commonly required by municipalities in congested sections. This form of construction is favorable to the maintenance of lines and the requirements of continuous service.

The provision of manholes of suitable size for the large transformer units required in sections where the load is very dense becomes a difficult problem. The presence of conduits, gas pipes, water pipes, car tracks, etc., utilizes so much space that it becomes a physical impossibility to secure clear space in manholes for large transformers, except by excavating to a depth where drainage becomes impossible. The difficulty and expense under such conditions may make it preferable to establish a transformer substation from which low tension feeders emanate as in direct-current systems.

These substations having no moving apparatus may be located in a comparatively small space in a basement so situated that the feeders may be short and may not require independent regulation.

The design of secondary systems is subject to some restriction, when inductive loads, such as arc lamps and motors must be served along with incandescent lighting.

The regulation of most transformers is not so good with inductive load as with non-inductive load, owing to the reactive drop in their windings. In case power and lighting loads are supplied from the same transformer the heavy starting current required by the induction motors may momentarily overload the transformer with current at low power factor. This low power-factor current drops the pressure on the secondary line for a few moments and causes a flickering of the incandescent lights. If the motor load is a considerable part of the total load the pressure remains lower while the motors are in operation and varies as the motor load changes. It is there-

fore necessary to install separate transformers for power load and for large installations of arc lamps where these constitute a majority of the load, if the best regulation is required for the incandescent lighting.

The regulation which will be secured with a given transformer may be calculated for any set of conditions which may arise, if the impedance drop of the transformer is known.

The impedance drop of a transformer is that pressure applied at the primary terminals which will cause full load current to flow in the secondary when its terminals are short circuited. For instance, in a certain 10 kw. transformer wound for 2200-110 volts, it was found that a pressure of 80 volts applied at the primary terminals would cause full load current to flow through an ammeter connected across the secondary terminals. The impedance drop was therefore 80.0 volts or 3.6 per cent. The impedance drop is the resultant of the resistance drop and the reactance drop just as in the case of an electric circuit. The resistance of the primary and secondary coils measured by means of direct current was found to be such that at full load the resistance drop was 1.8 per cent. or 40 volts.

The reactance drop is therefore—  

$$\sqrt{(80)^2 - (40)^2} =$$

$$\sqrt{6400 - 1600} = 69 \text{ volts} = 3.1\%$$

In Fig. 6 let  $OA$  be the impressed pressure on the primary at no load.  $AB$  is the ohmic drop in the transformer windings, which in this case is 40 volts. This is in opposition to the impressed electromotive force and must therefore be added directly to it in determining what pressure must be impressed on the transformer in order to deliver its rated secondary pressure at full load.  $BC$  represents the inductive drop of 69 volts which must be laid off at right angles to  $AB$ . The pressure necessary to secure 110 at the secondary at full load is therefore  $\sqrt{(2240)^2 + (69)^2} = 2241$  volts. With an incandescent lamp load of 100 per cent. power-factor the regulation of this transformer is therefore 1.8 per cent.

With a load of 10 apparent kw. at 70 per cent power-factor the regulation is calculated thus:

In Fig. 6 the impressed pressure, 2200 volts at no load is  $OE$ . This is opposed by a power consuming component in the load of  $OH = 0.7 \times 2200 = 1540$  volts, and a wattless component  $EH = 0.71 \times 110 = 1562$  volts. The ohmic drop in the transformer  $EF = 40$  volts and the inductive drop  $FG = 69$  volts. The impressed pressure at the primary necessary to maintain 110 volts at the secondary of the transformer is therefore—

$$OG = \sqrt{(OH + EF)^2 + (EH + FG)^2}$$

$$OG = \sqrt{(1580)^2 + (1631)^2} =$$

$$2270 \text{ volts.}$$

The drop at 70 degrees power factor full load is therefore 70 volts = 3.2 per cent. At 100 per cent. overload this would be 6.4 per cent. With a motor taking current at a power factor of 60 per cent. or less at starting it is evident that incandescent lights supplied by the same transformer will flicker whenever the motor is started and will burn at reduced candle-power while the motor is running, unless the motor load is so small compared with the lighting that the starting current is less than the full load current of the transformer.

With a load consisting of arc lamps the power factor is approximately 70 per cent. and the drop at full load is as in the foregoing case about 3.2 per cent. This would be considered too much for satisfactory incandescent lighting in many cases and if so it would be necessary to set a separate transformer for the arc lamps. When combined with an equal amount of incandescent lighting, the resulting power factor at the transformer is increased to about 93 per cent. and the regulation of the transformer is not excessive.

The table in Fig. 7 shows some of the characteristics of line transformers of the sizes commonly used, which will be of use in making calculations. Improvement has been made by reducing the reactance drop in the smaller sizes of transformers by some manufacturers in recent years. The installation of separate transformers for power load necessitates separate secondary systems for the power consumers whose premises are in the same vicinity. The design of power "secondaries" is governed by the same principles that control the arrangement of lighting mains, except that it is permissible to allow the regulation to be as high as 5 per cent instead of 2 per cent. It usually permits longer runs and requires no more copper than is necessary for carrying capacity. In manufacturing districts the power load usually exceeds the lighting, and duplicate secondary systems are frequent, though not close enough together to permit interconnection to any extent. In mercantile districts the reverse is the case and the heavy lighting secondary system is capable of absorbing miscellaneous power without seriously affecting the lighting service. The use of separate transformers for power in such sections is therefore not necessary except for occasional large consumers.

In two-phase systems having three-wire single-phase lighting secondaries

two additional secondary wires are required for two-phase power consumers, making a five-wire service necessary, where light and power are served in the same building.

In a three-phase system two methods of carrying mixed light and power load are available. The most commonly used consists of star-connected transformers supplying a four-wire main operated at 115 volts from phase to neutral and 200 volts across phase wires. Lights are balanced as nearly as possible on the three phases. The smaller lighting services may be made three-wire, being connected to two phases and neutral. Four-wire service is required wherever both light and power is to be served in the same building. The chief objections to this system are the difficulty of maintaining a balance and the necessity of installing three transformers at each point where the secondary main is fed.

In the other method, which is illustrated in Fig. 8, all the lighting is carried on one phase by means of a three-wire Edison secondary. Small power may then be served by the installation of one additional smaller transformer, and a fourth secondary wire operating on the open delta connection. Larger power may require two power transformers in addition to the lighting transformer. This system is easier to keep balanced, and since all the lighting is on one phase, permits the use of less transformer capacity for lighting purposes and re-

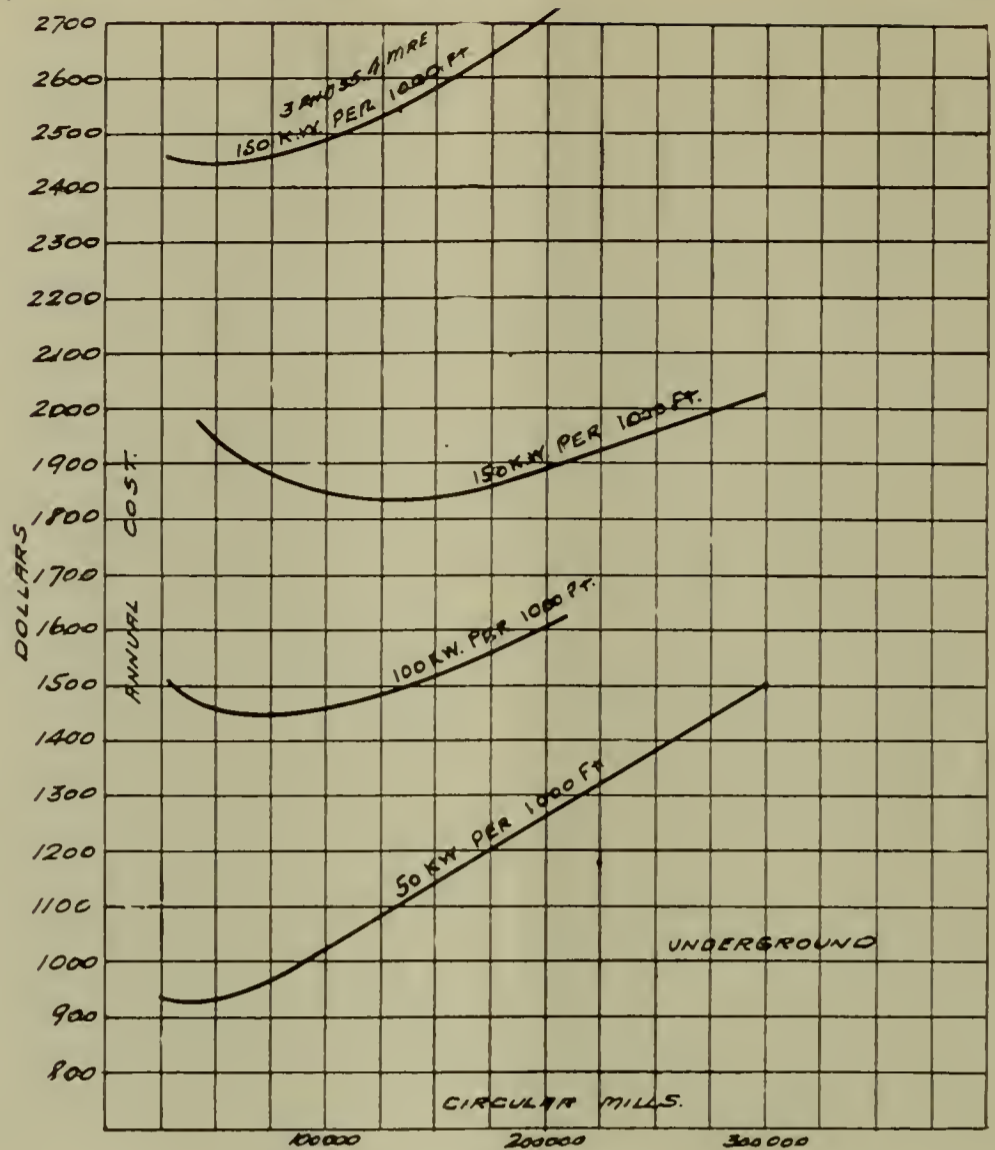

FIG. 5.

wire that in the case of a load density of 150 kw. per 1000 ft. on the four-wire three-phase system the minimum

ers of small capacity are required in the three-phase system as against one in the single-phase. The saving in wire due to the use of three-phase transmission is therefore much more than offset by the increased cost of transformers and greater iron losses.

Another advantage of the system in which all lights are carried on one phase is that the effect of the starting current of motors is noticed less on the lighting supplied by the large unit on the lighting phase than it is where the starting current is drawn from three small transformers, each of which carries lighting load. It is, therefore, possible with this system to carry larger power loads interconnected with the lighting than in the star-connected system under the same conditions.

Where a network has been developed, this system can, of course, not be interconnected with other secondary mains except those which are fed from the same primary phase. Under these conditions it is necessary to sectionalize the network so as to divide the load between the primary phases. As the size of the mains in the network increases this becomes undesirable, and the objections to the star-connected system becomes less important. The four secondary conductors may then be changed over to a star-connected system using the three heavy

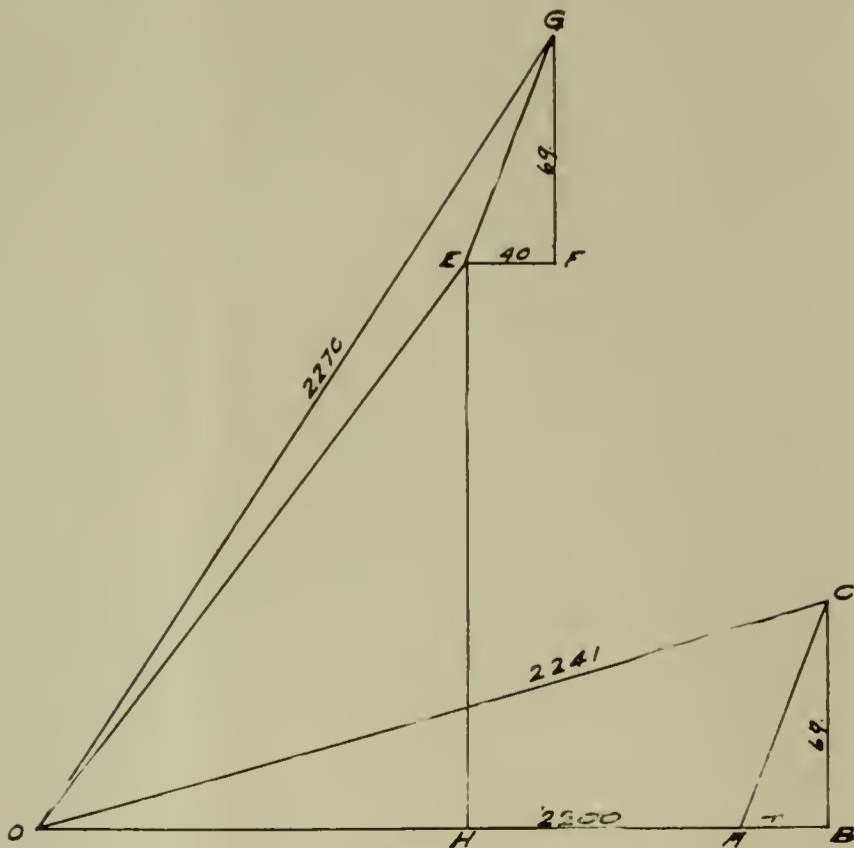

FIG. 6.

duces transformer investment and core loss materially as compared with the star-connected secondary.

It will be noted in the calculations made for the most economical size of

annual cost of such a system is \$1998.00, as compared with \$1413.00 for an Edison three-wire system with the same conditions. This difference is due to the fact that three transform-

conductors which were formerly used for lighting as the outer wires of the new system and the power wire as the neutral. The network may then be interconnected throughout and increased reliability of service thus secured.

The use of combined light and power secondary mains becomes desirable in an underground system as soon as there is a sufficient number of power consumers to warrant a general system of power secondaries in any locality.

The expense of extra ducts, man-holes, and separate cables for power secondaries soon becomes prohibitive and it is therefore found desirable to combine light and power secondaries into one system at an earlier stage of development than in the case of overhead lines.

The selection of the proper size of transformer for the supply of various classes of consumers is a matter of great importance since excess capacity involves idle investment as well as unnecessary core losses. The size of transformer units should therefore be kept as low as possible consistent with preservation of the apparatus and good regulation.

Very few electric light and power consumers use their entire connected load at any time. In lighting there are always some lamps which are not in use at times when the principal part of the lighting is on, and in power the load is frequently less than the rated capacity of the motor. Where there are a number of motors in use the maximum load is rarely on all of them at the same time.

Where a number of consumers are grouped on one transformer the maximum demands of the various consumers do not occur simultaneously and the resultant maximum demand must be ascertained by measurements. These measurements may be made by means

TRANSFORMER CHARACTERISTICS.

Capacity K. W.	Ohmic Drop Per Cent.	Impedance Drop Per Cent.	Regulation at 100 Per Cent., P. F.
1.	2.8	3.1	2.9
1.5	2.9	3.3	3.
2.	2.4	3.25	2.4
3.	2.1	3.25	2.2
4.	2.	3.25	2.1
5.	2.	3.3	2.08
7.5	1.9	3.3	2.
10.	1.8	3.7	1.9
15.	1.7	3.7	1.8
20.	1.65	3.6	1.7
25.	1.6	3.6	1.65
30.	1.6	3.5	1.63
40.	1.55	3.5	1.6
50.	1.5	3.4	1.6

FIG. 7.

of a split ring current transformer and ammeter or by the installation of a Wright demand indicator. The use of the demand indicator is preferable as it may be left in circuit throughout any desired period and the absolute

maximum for the entire period thus determined, whereas readings taken with an ammeter give results which are applicable only to the time at which the readings are taken. Certain ratios of maximum demand to connected loads may be established by a series of such measurements for the various class of consumers for which it is necessary to select transformers. These ratios may then be applied with reasonable certainty to the selection of transformers for new consumers.

For instance, it has been found in the City of Chicago that in store lighting the maximum demand for window lighting, signs and other display lighting is practically 100 per cent. of the connected load. The demand on interior store lighting is 75 to 80 per cent. There are usually two or three nights in the week in which the demand will be less than this.

In residences where the connected

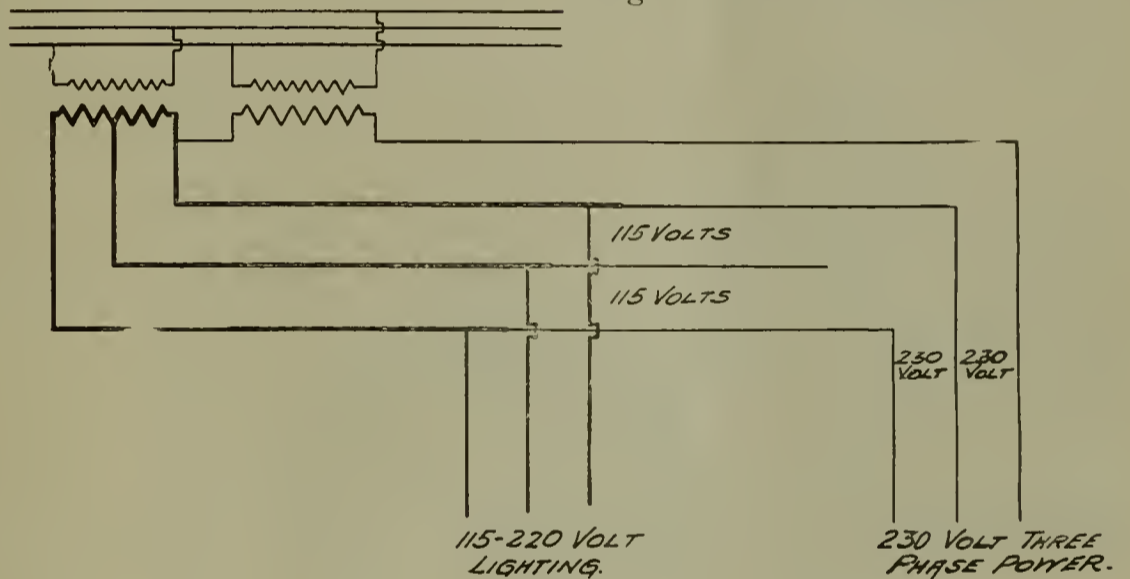

FIG. 8.

load is 50 lights or more, the average maximum demand of a group of residences is 15 to 20 per cent. of the connected load. Individual residences may have occasional maximums of 30 to 50 per cent. for which some allowance should be made in selecting transformer capacity. The size of the transformer should be such that it will carry the occasional high maximum of the largest individual consumer together with the average maximum of the other consumers on the transformer. Oil transformers may safely be permitted to carry 25 to 50 per cent. overload occasionally in such cases.

Small residences and apartments having connected loads of 40 lights or under average about 20 per cent. of the connected load, with 25 to 30 per cent. as an occasional maximum.

In general, a higher ratio must be used where there are but two or three consumers on a transformer than where there are 10 or more consumers, as the occasional maximum of indi-

vidual consumers is a much larger percentage of the total.

In the case of churches and similar public buildings capacity must be provided for the illumination of the largest room in the building together with the necessary hallways and corridors. This usually requires capacity for at least 75 per cent. of the connected load.

In theater lighting allowance may be made for the use of border and foot lights of several colors which are not used simultaneously and for the fact that the stage and auditorium are not lighted simultaneously except for a very few minutes at a time. In a small theater the ratio may be from 70 to 85 per cent. while in a large theater it frequently runs as low as 50 per cent.

Where several classes of buildings are fed by one transformer, the capacity must, of course, be determined by taking each class into consideration separately and thus arriving at an average ratio for the whole.

The selection of transformers for power consumers is a more difficult task, as the maximum load may vary greatly from day to day or from month to month. Consumers having but one or two motors generally require from 60 to 90 per cent. of the aggregate horse power of their machines. The connected load should be estimated where possible from the nature of the work done rather than from the motor rating, as motors are frequently chosen with reserve capacity. Where there is a considerable number of motors the maximum load is often not more than 40 to 50 per cent. of the aggregate rated horse power of the motors. Elevator and crane motors require transformers of 100 to 125 per cent. of their rated capacity unless there are several motors supplied by one unit. This is necessary in order to hold up the pressure in starting. The load of such equipments is so intermittent that heating is usually not a factor in determining the size of the transformer.

# Cost of a Single-Phase Line Equipment

JOHN HAYS SMITH

ANYONE who has gone deeply into the subject of railroad electrification costs cannot fail to be impressed with the courage and progressive spirit of the N. Y., N. H. & H. R. R. in venturing on such a big experiment as the application of the single-phase system to their lines.

That the system will work, and work well when everything is adjusted, is a foregone conclusion, but it is interesting, at this time, to consider what it has cost in order to form some idea of the availability of the system for general railroad electrification.

While the New Haven engineers have not, and probably will never publish the details of cost of their system, the descriptions which they have permitted to be published from time to time now enable an engineer with estimating experience to form a fairly close estimate of what the system has cost.

The estimate given below is based on the New Haven R. R. descriptions which have appeared at various times in the technical press, and on unit prices now prevailing. The details are tabulated at the end of this article, and it should be noted that the esti-

mate is probably very low on account of the omission of special work at low street bridges and of extra large bridge foundations, which occur very frequently.

## SUMMARY.

Per mile of 4-track line.	
Contact System.....	\$36,388
Feeder System.....	1,890
Track Bonds.....	1,800
Total .....	<u>\$40,078</u>

While the cost of the New Haven power-station may be readily estimated (being from \$85 to \$90 per rated kilowatt), it depends principally on the train tonnage to be moved and very little on the length of line. It is therefore of no interest to classify it with the items which depend directly on the track mileage, as the total would then be inapplicable to other systems.

According to the New York Central time-table, it is 440 miles from New York to Buffalo, and the line is described therein as four-track. Using the above unit price per mile, the cost of electrifying the New York Central to Buffalo would be about 40,000 by 440 = \$17,600,000, exclusive of power-stations and locomotives. This is a very low figure, as no special work is allowed for such as would be required going through Syracuse in the open streets, etc., and under the hundreds of street and road crossings.

It would appear that the electrification of trunk lines will be retarded until some economies are effected in contact line cost.

An item having a commercial as well as humanitarian aspect is the danger of the high-tension trolley to employees. The loss of life on the New Haven system from 11,000-volt shocks has been very serious; the author has no exact statistics to date, but remembers seven cases during what was practically experimental operation. The result of this at the present time is great delay in executing repairs, owing to the unwillingness of employees to touch the wires without elaborate precautions. This contrasts most unfavorably with the 600-volt third-rail system, which is easily in repair while alive.

## CONTACT LINE AND SUPPORTS

ITEM	Quantity—Unit	Price	Per mile of single track	Per mile of four tracks
Steel bridges, intermediate; every 300 ft., wgt. 13,000 lbs.	115 tons	\$100.00		11,500
Steel bridges, anchor; every 2 miles, wgt. 23,000 lbs.	5 <sup>3</sup> / <sub>4</sub> tons	100.00		575
Foundations for intermediate bridge, 9 cu. yds. each side; 34 per mile	306 yds.	10.00		3,060
Foundations for anchor bridge, 12 cu. yds., 1 per mile.	12 yds.	10.00		120
Special foundations.....				775
Trolley wire, No. 0000 B. & S., 5,280 ft.	3,280 lbs.	.18	607	
Messenger wires, two 5/8 in. steel, 10,900 ft.	9,150 lbs.	.08	732	
Hangers, 10 ft. apart.....	528	.75	395	
Insulators, two every 300 ft.	34	.50	17	
Pins and yokes for above.....	34	.75	26	
Strain insulators and accessories, 16 every two miles.	8	6.00	48	
Trolley strain insulators and section breaks, 4 every 2 miles.....	2	16.00	32	
Circuit breakers, 8 per section.....	4	500.00	2,000	
Linesmen's materials.....			20	
Labor on trolley, messengers, and supports.....			1,200	
			5077x4	20,308
Total for Contact System.....				36,388

## FEEDER SYSTEM

ITEM	Quantity—Unit	Price	Per mile of single track	Per mile of four tracks
Feeder wires, No. 0 B. & S. (two), 10,900 ft.	3,380 lbs.	\$ .18		608
Insulators.....	35	.50		18
Pins.....	35	.50		17
Circuit breakers.....	1	500.00		500
Control wire and pipe.....	500 ft.	.50		250
Control transformers, 5 kw., 2 per section.....	1	100.00		100
Lightning arresters.....				50
Miscellaneous material.....				20
Labor on feeders.....	10,900 ft.	.03		327
				1,890

## TRACK BONDS

ITEM	Quantity—Unit	Price	Per mile of single track	Per mile of four tracks
Bonds, No. 000, B. & S., 32 in., 1 1/2 in. terminal expanded.....	353	\$ .83	300	
Labor.....	353	.43	150	
			450x4	1,800

# The Richmond and Chesapeake Bay Single-Phase Railway, Richmond, Va.

FRANK C. PERKINS

THE accompanying illustrations and drawings show the construction and the electrical equipment of the Richmond and Chesapeake Bay Railway, a single-phase electric line recently placed in operation in Virginia and extending a distance of about 15 miles to Ashland from the City of Richmond.

The power for operating this single-phase electric railway is supplied by the Virginia Passenger and Power Company from its Twelfth-Street power-house at a pressure of 6600 volts. The current is transmitted to the trolley line at Richmond by underground cables, and is utilized directly at the above pressure without being transformed in any way, no substation being utilized except for lighting service at Ashland.

The electrical equipment was installed by the General Electrical Company, and the cars were built by the St. Louis Car Company, the trucks being manufactured by the Baldwin Locomotive Works.

The cars are about 54 ft. long over all, and 9 ft. 10 in. in width, the bottom framing of the car consisting of yellow pine side sills reinforced by steel plates, the intermediate sills being 6 inch I-beams. The electrical equipment of the cars is of the multiple-unit type, with four General Electric motors of the single-phase railway type, arranged with duplicate control. It is stated that the apparatus is so arranged that each pair of motors and the compensator, as well as their contactors, are entirely independent of the second similar equipment, so that in case of any accident to any of the apparatus the other two motor equipments may be utilized for operating the car. For transferring the auxiliary circuits for heating and lighting from one compensator to the other double throw switches are used.

It is held that oil-cooled railway compensators, designed for 6600 volts at 25 cycles, are arranged with taps giving from 600 volts down to 113 volts, and that these are the first General-Electric equipments put into operation with two compensators. On the auxiliary circuit only are the 600-volt taps used, and the cables are introduced into the tanks, which are made of fluted steel through special stuffing boxes.

The cars are provided with two trolleys of the pantograph type built

with steel pans, which are said to be better than aluminum or copper, these pans being provided with grooves for receiving a lubricant.

The cars have wheels 38 in. in diameter on axles,  $6\frac{1}{2}$  in. at the center and  $7\frac{3}{4}$  in. at the gear seats. The wheel base is  $7\frac{1}{2}$  ft. and total weight of each truck is about eight tons.

The four motors have a capacity of 500 h.p., and are of the series repulsion type designed for sustaining very heavy overloads without injury. Each of the motors has a rated capacity of 125 h.p., but is capable of developing far greater power, the overload capacity, it is claimed, being due to the fact that the whole space in the slots

E. P. Allis type have been installed, each having a capacity of 1000 h.p. These engines have a stroke of  $3\frac{1}{2}$  ft., the high-pressure and low-pressure cylinder measuring 20 in. and 40 in. in diameter, respectively. The engines are directly coupled to 750 kw. direct-current generators of the General Electric type. The hydraulic turbines are located under the boiler-room, the latter being equipped with six water-tube boilers of the Babcock and Wilcox type, each having a capacity of 500 h.p. with a steam pressure of 145 lb.

In this power-house of the Virginia Passenger and Power Company is installed the unique generating equip-



END VIEW OF SINGLE-PHASE CAR—RICHMOND & CHESAPEAKE BAY RAILWAY.

is available for copper, and that there is no excessive heating as when the leads are of high resistance.

At the power-house on the James River there are steam engines provided, as the hydro-electric equipment cannot be depended upon on account of the variable capacity of the river, although a dam has been built to provide for water storage.

In order to have sufficient power available at all times, five vertical tandem compound engines of the

ment of the Richmond and Chesapeake Railway. This machinery included two three-phase railway generators of 750 kw., each operating at a speed of 128 rev. per min., and supplying a current having a frequency of 25 periods and a pressure of 6600 volts, or 13,200 volts.

There is a hydraulic turbine provided of 1450 h.p. with one of the above-mentioned generators directly connected at one end, and at the other end of the turbine a 750 kw. three-

phase generator supplying a 2300-volt current at a frequency of 60 cycles.

This really amounts to a direct-connected motor-generator set, the

be used as a motor when there is not enough water to operate the hydraulic turbine. The 1000-h.p. engines of the vertical type referred to

electric power in case the hydraulic turbine cannot be used.

It is stated that when water-power is available for driving the railway company's generator the direct current, as well as the alternating-current machines, may be utilized for city lighting, and the railway company's generator may be driven by a direct current, or by water-power, or by an alternating current of 60 cycles. It is stated that one phase of the 25-cycle three-phase alternators is used to supply the single-phase 6600-volt alternating current under the present operating conditions.

The Richmond and Chesapeake Bay Trolley line is supplied with a single-phase alternating current of 6600 volts from the Terminal Depot at Richmond, it being conducted to this point by an underground transmission cable in a conduit of vitrified earthenware, the total distance being about 1½ miles from the depot to the power-house.

The overhead construction, as seen in the accompanying illustrations, is of the suspended catenary form, with No. 0000 grooved copper wire for the trolley itself with a seven-strand steel messenger cable ¾ in. in diameter provided, which has a tensile strength of 5½ tons. The vertical columns are made up of steel pipes three inches in diameter with a horizontal bar two inches in diameter, malleable



VIEW OF REINFORCED CONCRETE VIADUCT—RICHMOND & CHESAPEAKE BAY RAILWAY.

electric units being mounted on a common base and so arranged that the three-phase 60-cycle generator may

above operate direct-current generators of 750 kw. each, and the current from these units may be used for operating another motor-generator set, which is also combined with a hydraulic turbine.

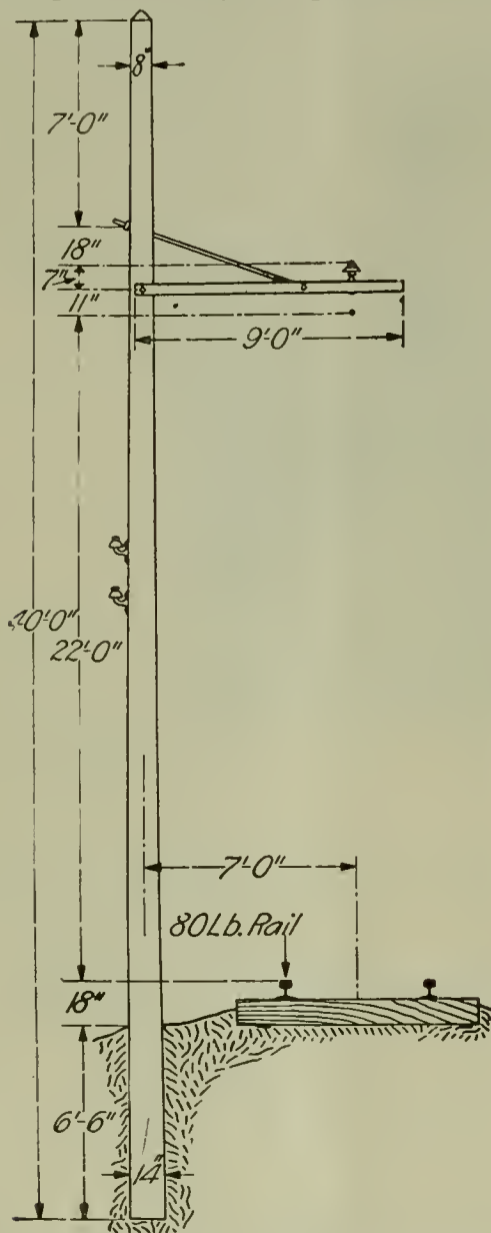

TYPE OF BRACKET CONSTRUCTION USED ON RICHMOND & CHESAPEAKE BAY RAILWAY.



INSULATED CROSS-OVER FOR 600 VOLTS SINGLE PHASE DIRECT CURRENT AND 6600 VOLTS ALTERNATING CURRENT—RICHMOND & CHESAPEAKE BAY RAILWAY.

This outfit consists of a water turbine directly coupled to a 25-cycle alternator at one of the shafts and a direct-current generator of 750-kw. capacity at the other end, this dynamo being used as a continuous motor for operating the 25-cycle generator by

iron elbows being used. The poles are 40 ft. in height and the trolley is located 22 ft. from the rail level for the overhead construction of the bracket type between the Ashland terminus and the Richmond viaduct.

The insulators are 6¾ in. in di-



ameter and are 4½ in. high, tested to a pressure of 50 thousand volts and supplied by the Locke Insulator Company and the General Electric Company. The poles are placed 120 ft. apart on the level tangent track, while at curves and highway crossings the spacing is reduced to 60 ft.

There is one substation at Ashland for reducing the pressure from 6600 volts to 440 volts, and from the low-tension transformer terminals leads are passed through a phase-splitting device, which consists of a resistance and a reactance, before being connected with the induction motor of the single-phase alternating-current type.

The motor-generator set provided consist of this single-phase induction motor, above referred to, directly coupled to a single-phase alternator, which supplies current to the lighting feeders at a pressure of 2300 volts.

The two step-down transformers, above mentioned, are of the oil-cooled type of 150-kw. capacity, and they supply current to the 150-h.p. motor at 440 volts and 25 cycles, while the 100 kw. single-phase generator of the motor-generator set, operating at a speed of 720 rev. per min., supplies a single-phase alternating current having a frequency of 60 cycles, at which frequency the current is used for lighting the station with arc lamps and General Electric tungsten lamps.

The Richmond Terminal Depot is built of brick and is provided with an electrically operated hoist for raising the freight to the station floor level. The terminal depot at Ashland, containing the lighting substation

above described, is a wooden building with platform extending entirely around the structure eight feet in width.

There is a viaduct of reinforced concrete more than half a mile in length constructed to carry the track

of 14.8 miles. These rails are spiked to the ties, which are of white oak 8½ ft. long and 7 by 8 in. in cross-section.

It is stated that the maximum curve on this single-phase electric railway is 412 ft. long and a trifle over 7



GENERAL VIEW OF TYPICAL TURN-OUT ON RICHMOND & CHESAPEAKE BAY RAILWAY.

through the suburbs of the City of Richmond at a high level varying from 18 to 70 ft. above the street. The spans are from 23 1/3 ft. to 66 ft. in length, and expansion joints are provided every 200 ft. for arranging for the variation in temperature. The rails used are of the standard 80-lb. type over the whole length of the line

degrees, while 1 per cent. is the maximum grade on this single-phase road. It is maintained that the first extension considered for this line is from Ashland to Tappahannock on the Rappahannock, and it is held that the construction of a line through this district would be very profitable not only for passengers but for freight traffic.

### A Short Circuit Interrupter

WILLIAM A. DEL MAR

Long direct-current feeders have the serious fault of being liable to short circuits, or grounds, which may be of sufficient magnitude to cause great damage, but not to open circuit breakers set high enough to meet the regular load demands in heavy traction.

In order to meet this condition, the writer devised the scheme outlined below whereby a short circuit, or ground, is made distinguishable from a heavy legitimate load, so that the circuit breaker will respond to the former, but not to the latter.

The system consists in incorporating in, or attaching to, the feeder cable a small insulated wire, which is connected in circuit with a relay and source of current in such a way that the relay will operate when this small wire is severed at any point, either from a short circuit or any other cause. The relay is connected to the

shunt trip coil of the circuit breaker, so that the operation of the relay actuates the latter and opens the circuit breaker.

This scheme was worked out by the writer about two years ago, and has been put into use on the direct-current feeders of the New York Central Railroad electric system. Among the features worked out at the time referred to above was the application of the system to third rails, and the in-

corporation in the feeder cables of an insulated strand to be used in connection with the system. The use of the system by the New York Central Railroad was described by Mr. W. J. Wilgus before the American Society of Civil Engineers, and had been elsewhere commented upon favorably by New York Central officials.

Premature publication of the system prevented patenting, so that it is now available to all who wish to use it.

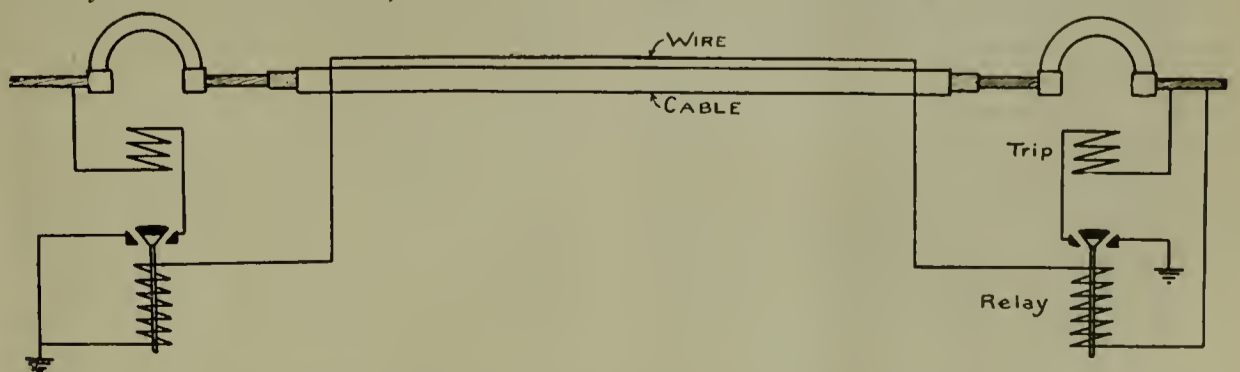

DIAGRAM OF CONNECTIONS OF SHORT CIRCUIT INTERRUPTER WIRE. (If there were two cables, the return, instead of being grounded, would be the wire on the second cable.)

# The Problem of Illumination

ARTHUR J. SWEET

I.

IN most of the fields in which the engineering sciences are applied to forwarding the world's comfort and to doing the world's work, the question of the efficiency of the apparatus employed and of the installation as a whole is one which must receive the very serious consideration of both the designing engineer and the man who pays the bills. In few of these applied sciences, however, is efficiency of such supreme importance as in illumination. In the application, for instance, of electrical energy to mechanical work through the agency of the electrical motor, the primary consideration is usually the reliability of the apparatus for service whenever required, while efficiency, though an important, is none the less a secondary consideration. In the air-brake or in the signal system, reliability of service is of vastly more importance than operation at an efficient power consumption. In illumination, however, efficiency of operation is a consideration so paramount that it may rightly be called *the* problem of illumination.\*

I fancy there are two possible questions which may be raised by those who hesitate to accept the statement that the problem of illumination is essentially a problem of efficiency. "We agree," one party may say, "that the issue is one of satisfactory illumination at low cost; but is efficiency of operation the all-important factor of the cost? Is not the useful life of the illuminating apparatus of equal or greater importance?" The question here raised can easily be settled beyond dispute and settled once for all. Those who are most apt to lay great importance on the question of useful life are those who use the incandescent lamp as a source of illumination. In Fig. 1 is shown the relation which the renewal cost of the lamp bears to the power consumption cost at different costs of power per kilowatt-hour. The curves apply to the 16-c-p., 3.1 watts per c-p., 110-volt carbon filament lamp. Curve A represents the renewal cost expressed as a percentage of the total cost of operation, including renewal. Curve B represents power-consumption cost, likewise expressed as a percentage of the total cost. This curve sheet shows that, at all costs at

which it is practicable to generate electrical energy, the power-consumption cost is considerably greater than the renewal cost. Within the range of cost at which electrical energy is commonly available to the user of light, 8 cents to 15 cents per kilowatt-hour, the renewal cost is an almost negligible factor as compared to the power-consumption cost—I have chosen the most efficient carbon filament lamp to illustrate the case; had a less efficient lamp been taken, the life of the lamp would have shown up as a still less important factor.

It is obvious that in the case of gas in open burners, and of spirits or oil illuminants, the life of the illuminating apparatus is a very trivial factor in the total cost of operation. In the case of the gas mantle, Nernst lamp, mercury vapor lamp, or any of the various forms of arc lamp which are

many another applied science, art and efficiency go hand in hand. Not all so-called artistic installations are efficient, but the truly efficient installation is almost invariably artistic in the best and highest sense of that much abused word. And therein lies the answer to our critics. Efficiency comes first. We must seek efficiency with a single eye and satisfy its canons. Only by so doing can we lay the secure foundations upon which the superstructure of true art must be built.

Perhaps the expression of these principles in general terms seems abstract, almost meaningless. Take a concrete example. A false sense of the artistic, which finds much favor at the present time, decrees that the incandescent lamp must not be suspended vertically from the chandelier, but at an angle to the vertical. The same artistic sense surrounds the lamp

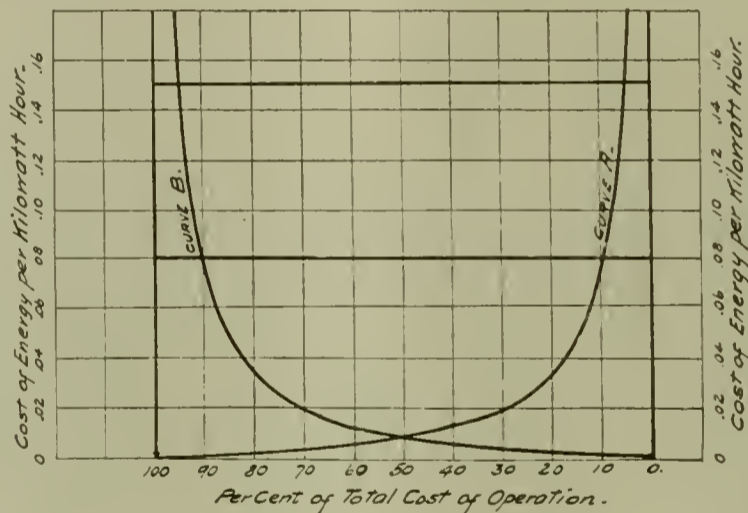

FIG. 1.

in extended commercial use, the renewal cost bears to the power-consumption cost a relation similar to that which we have already found true for the incandescent lamp.

We have seen that the useful life of the illuminating apparatus is of minor importance in the problem of illumination, as compared with efficiency of operation. There is yet one other party of critics who have a right to be heard. These will assert that the artistic quality of the installation is frequently of more importance than its efficiency. If artistic merit and efficiency were antagonistic, or even independent principles, these critics would be right. We do desire beauty in our surroundings, and we will have it, if necessary, at the cost of dollars and cents. But in illumination, as in

with a reflecting glass shade. With such an installation, whenever one faces the chandelier even partially, one is struck in the face with a beam of light. The result is not merely unpleasant, but inartistic in the highest degree. Had the problem of efficiency first been studied it would have been found that the most efficient position, the vertical, is also the most artistic in the illumination results attained.

I have thought it worth our while to discuss at some length the proposition implied in the title of this paper. The problem of efficiency is the fundamental problem of illumination. The laws upon which efficiency of illumination depends are to become the fundamental laws of the new-born science of illuminating engineering. Our natural and only logical procedure,

\*A paper delivered before the Pittsburg section of the American Institute of Electrical Engineers at meeting January 8, 1908.

therefore, as students of the new science, is to analyze the various factors which determine the efficiency of illumination and to recognize and classify the laws according to which these factors act.

## II.

At the outset it is necessary to have a clear conception of what is meant in illuminating engineering by efficiency. In the older and better-established engineering sciences efficiency is regularly taken to mean the useful energy output of the apparatus or installation divided by the energy input, the result being expressed as a percentage. In the practice of these sciences, the end sought is the transformation of one purely physical form of energy—mechanical, electrical, chemical—into another purely physical form of energy. In illumination, however, the end sought is a physiological process—sight. The difficulty of measuring efficiency of illumination at once becomes apparent. Watts and horse power can be reduced to a common unit and the one divided by the other. But what common unit can be found between watts and the sensation called clear vision? Does clear vision under different illumination conditions represent always the same amount of energy expended in the physiological process? Can, indeed, any satisfactory unit of "clearness of vision" be found, whether energy unit or otherwise?

It is foreign to the purpose of this paper to follow the inquiry into which these and kindred questions would lead. It is sufficient for present purposes to recognize that illuminating engineering has as yet no unit of efficiency. None the less, the term efficiency can be used, and the distinctions of higher and lower efficiency can be drawn. That such practice is legitimate a moment's consideration will make clear. It has already been pointed out that in the older engineering sciences efficiency varies directly as the useful energy output and inversely as the energy in-put. If, now, either useful output or energy in-put can be brought to a given definite condition, relative efficiency at that condition can be expressed in terms of the other quantity. In illumination there is, for any given installation, a fairly definite condition known as "good illumination." For any given plane of reference, or for any combination of such planes, the relation of efficiencies of two different schemes of illumination will be the inverse relation of the energy in-put required to produce "good illumination" in each case.

"Good illumination" is indeed a rough and inexact measure for a sci-

ence which seeks to be exact. But however ill we like it, we will be the better engineers for clearly recognizing that it is at present the only measure we have of useful energy output—of the energy which is active in stimulating the optic nerve and producing visual perception.

This, then, is the situation in which the illuminating engineer finds himself. His problem is fundamentally a problem of efficiency—the problem of using the energy at his disposal so as to accomplish the greatest amount of useful work measured in terms of visual perception. He has, however, as yet no unit of efficiency. He cannot, therefore, measure efficiencies in absolute terms. He can, however, compare the relative efficiencies in inverse terms of energy in-put required to produce a certain condition of visual perception popularly termed "good illumination." He can, moreover, determine the laws on which efficiency depends and apply those laws so as to produce highly satisfactory practical results, even though he cannot express in absolute terms the results attained.

## III.

When the term "efficiency of illumination" is considered closely, it is seen that in this term is included the combined effect of three different kinds of efficiencies. First, there is the efficiency of the light source, by which is meant the efficiency with which chemical or electrical energy is transformed into light energy. Second, there is the efficiency of light distribution, by which is meant the relation between total light energy generated and light energy useful in producing desired conditions for visual perception. Third, there is the efficiency of visual perception, this being the efficiency with which the eye receives light energy and transforms it into visual perception. None of these factors is trivial—each is of tremendous importance in determining the resultant efficiency of illumination. It has been the error of the past to lay all the emphasis on the efficiency of the light source. With the development of illuminating engineering, and particularly as a result of the admirable work of Mr. Van Rensselaer Lansingh, there is coming to be a general realization of the importance of light distribution. It remains for the future to recognize that efficiency of visual perception is a factor which cannot be neglected.

Our problem lies clear before us. We seek efficient illumination. To obtain it we must have efficiency of visual perception, of light distribution, of light source—all three. What, then, are the conditions upon which

each of these three kinds of efficiencies depend?

## IV.

Efficiency of visual perception depends upon three conditions. These are (a) the intrinsic brilliancy of the light source and of the surrounding light-reflecting objects; (b) the color of the light; and (c) the intensity and steadiness of the light. Each of these conditions will be briefly considered in turn.

(a) Intrinsic brilliancy of light source. It is a well-known fact that the eye adjusts itself to various degrees of light intensity by the automatic expansion or contraction of the pupil—that opening in the iris diaphragm through which light is admitted to the eye. Now, the light which is active in causing a greater or less contraction of the pupil is not merely the light which comes from the center of the field of vision, but the light which comes from the entire field of vision. The light which is active in causing visual perception, however, comes under normal conditions entirely from the central portion of the field of vision. The same amount of light, therefore, falling upon and reflected from the given visualized object may produce very different degrees of illumination due to changes in the size of the pupil, such differences resulting from differences in the intrinsic brilliancy of the outlying portions of the field of vision.

A concrete example will make clearer. One sits reading, let us say, in a room with dark-colored walls, the only source of light being above and behind the reader, entirely outside of his field of vision. Photometric measurements of light intensity on the printed page give results of two foot-candles. The reader calls it good illumination. Now we will introduce a second light source, say a brilliantly incandescent Welsbach mantle or a tungsten lamp, into the reader's field of vision, screening the printed page so that it gets no light from the new light source. Gradually we will bring the new light source more and more to the center of the reader's field of vision. Just so gradually the pupil of the reader's eye contracts, admitting to the retina less and less light from the printed page. When the new light source, still screened from the printed page, has been brought near the center of the reader's field of vision, photometric measurements are again made and the results again announced to be two foot-candles. "I know nothing about your foot-candles," is the reader's impatient reply, "but I call it mighty poor illumination."

White or very light colored walls and ceilings, if brightly lighted, may

have an effect in contracting the pupil similar to a bright light source in the field of vision.

The competent illuminating engineer recognizes the serious decrease in efficiency which results from brilliant light sources or brilliantly lighted white walls, and he embodies that recognition in the following concrete rules of practice.

Whenever a brilliant light source is so placed that it may come within the field of vision, reduce to a low value the intrinsic brilliancy of that light source by a diffusing sphere, bowl, stalactite or bell-shaped shade. Never use a bare incandescent lamp, nor the Welsbach mantle with no shade other than the clear glass chimney or mica chimney.

Do not illuminate light-colored walls or ceilings too brilliantly.

This last rule, and the physiological conditions which justify it, are ignored by those who recommend installations of what is usually called cove-lighting.

A study of the effect produced on the efficiency of illumination by unshaded light sources and by brilliantly lighted white walls is recommended to those who seek to apply the foot-candle as an adequate measure of illumination.

(b) Color of light used. The effect on efficiency of visual perception arising from the color of the light is a subject too involved and at the present time too little understood to warrant discussion. It is sufficient to say that for the same light intensity as measured in foot-candles, lights of different color give appreciably different illumination values. For illumination where objects of a great variety of color are to be viewed, the best light is probably light of the quality of summer daylight—that is, light containing all wave lengths, but having a slightly undue preponderance of the green rays. For illumination of black and white effects, as drafting-room illumination, it is an open question whether modified white light, such as just described, or green light as of the mercury-paper lamp, is most suitable.

(c) Intensity and steadiness of the light. It is a common fallacy to assume that the more light, the better illumination. As a matter of fact, for any given integral of light intensity in the outer portions of the field of vision there is a corresponding definite intensity of light for the central portion of the field of vision which will give best conditions for visual perception. Greater intensities than this will produce gradual or rapid fatigue of the eye, resulting in less clear vision. A flickering, unsteady light also pro-

duces rapid fatigue of the eye functions. For this reason the old style open gas burner should never be used unless protected from air currents by a chimney. Burners employing incandescent mantles are free from this defect.

It is here intended to point out only the relations which intensity and steadiness of light bear toward efficiency of visual perception. In addition to this effect on efficiency of visual perception, and separate from it, is the permanently injurious effect on the eye which unsteadiness and too great an intensity of light may have.

To recapitulate, increased efficiency of visual perception may be obtained by detailed application of the following general rules. Reduce to a low value the intrinsic brilliancy of the light source on all sides exposed to the eye; avoid intensity of light on light-colored walls or ceilings; use light of correct color value; avoid unsteady light, and avoid excessive intensity of light on surfaces which are constantly or frequently objects of visual perception.

#### V.

The second kind of efficiency with which the illuminating engineer has to deal, efficiency of light distribution, depends upon two important factors: (a) the distribution of light which emanates from the illuminating unit and (b) the size of the unit and the location of centers of light distribution.

Light is a very unstable form of energy. It may be generated only with poor efficiency, and, once obtained, it slips back under ordinary conditions almost immediately into other forms of energy. Absorption is the chief process by which light energy is lost as such. Excluding mirrors and surfaces especially prepared for reflecting purposes, when light falls upon any of the surfaces with which we are commonly surrounded, a very considerable percentage is absorbed, while the rest, usually the much smaller part, is reflected. To give average figures, the percentage of light which is reflected from differently colored papers is as follows:

Table 1

White paper.....	80%
Orange paper.....	50%
Yellow paper.....	40%
Light pink paper.....	35%
Light blue paper.....	25%
Emerald green paper.....	18%
Dark brown paper.....	10%

These figures make it obvious that, if light is to be used efficiently, it must not undergo many reflections, losing in each as it does under average conditions, say 70 per cent. in intensity. Indeed, ideal efficiency of distribution is obtained only when all of

the rays emitted by the illuminating unit proceed directly and in proper proportion to the various surfaces to be illuminated, whence they are reflected into the receiving eye. *In proper proportion*, it is said. For suppose the illuminating unit emits in one direction more rays than required to give the proper illumination of the surfaces A, B, C on which they fall. A large number of these additional and unnecessary rays will be absorbed, which means that that much light is wasted, thrown away. Such of these rays as are not absorbed will be diffusely reflected. Now these diffusely reflected rays will decrease rather than increase the effectiveness of illumination of the surfaces A, B, C, for without them we had the correct degree of illumination. Most of these diffusely reflected rays, however, will not enter the eye, but will fall on the other surfaces, D, E, F. Here there will be another absorption. The few rays that remain may, it is true, be useful in the illumination of the surfaces D, E, F, but at what a sacrifice of efficiency is such illumination obtained?

The facts here adduced are so well known that detailed discussion of them seems trite. Nevertheless they are largely ignored in the vast majority of existing installations. There are few present installations in which the power consumption required to operate cannot be halved, or the efficiency of illumination doubled, by utilization of the light now needlessly wasted through absorption. Here, then, is a factor just as important for efficiency of illumination and just as deserving of attention as the recent developments in high-efficiency incandescent lamps.

It has been stated that the ideal efficiency of distribution is obtained only when all the rays emitted by the illuminating unit proceed directly and in proper proportion to the various surfaces to be illuminated. When attempt is made to realize this ideal, an apparently serious difficulty is encountered. None of the present light sources give of themselves such light distribution as to fulfil even approximately the condition just stated. The Nernst lamp and the inverted gas mantle give better distribution than any of the other largely used light sources, but even the distribution of these is unsuitable when high efficiency of illumination is sought. Fortunately the distribution of the bare light source can be greatly modified and highly efficient distribution obtained by the use of reflecting or refracting shades or globes. Of these various means for modifying and making efficient the distribution,

prismatic glassware stands away and above all others as best accomplishing the desired results. Indeed, where strong concentration is wanted in one direction and at the same time a small amount of light in all other directions—a frequently desired form of distribution—prismatic glassware is the only means at present known which will accomplish this result. For broad downward distribution of light, satisfactory results can be obtained by the use of suitably shaped opal or green-enameled glassware. The etched glass shades so frequently used are inefficient and unsuited for properly modifying the distribution. Where large areas are to be illuminated from a few light sources, excellent distribution can be obtained by the use of sand-blasted or opal glass globe with flat conical reflector of green-enameled or opal glass mounted immediately above the globe.

The application of suitable glassware to give proper distribution results is a problem which should not be attempted by engineer or layman unless he be especially trained and fully qualified as an illuminating engineer. No educated man, much less a scientifically trained man, would think of going to an optician's store and selecting a pair of eye-glasses because the curvature of the lens looks suitable to him, or because the mounting was artistic. Yet procedure no whit less ridiculous is the common occurrence in illumination problems. The writer has known trained engineers, men in some cases of unusual ability, to install prismatic glassware without even knowing the distribution effects given by the particular type in question. Sharp downward concentration, perhaps, was desired; yet the reflectors were installed in utter ignorance of whether they threw maximum light downward or maximum light laterally with minimum light downward. And when poor illumination results were obtained, as was to be expected, the conclusion was drawn that prismatic glassware was a greatly overrated product. It is a fact too little appreciated that the problem of obtaining efficient distribution is a complex, technical problem, requiring for its solution highly specialized knowledge of the physics of light and of the materials of illumination, and a broad experience with illumination installations.

The foregoing may profitably be summarized and emphasized as follows:

First, a correct distribution of light about the illuminating unit is an indispensable condition to efficient illumination and low cost of operation.

Second, no light source now on the

market gives of itself correct distribution. Hence suitable glassware to modify and correct the distribution should invariably be used.

Third, the problem of correct distribution and proper means of obtaining it is a highly technical problem to be solved only by the competent illuminating engineer.

The size of the illuminating unit and the location of centers of light distribution is a second important factor in efficiency of distribution. Each installation is so much a particular problem that it is difficult to lay down any universal laws expressing the relation of these factors to efficiency of distribution. The following rules, however, will be found to have a general application.

The center of light distribution should be located over each point at which relatively high intensity of light is desired. The need of additional centers and the location of such varies with the particular problem.

Avoid too many centers of distribution. Such design is not only costly to install, but less efficient in operation.

be obtained by means independent of the wall brackets.

In applying the above rule to residence lighting, and observing the principles already stated that too much light is just as much to be avoided as too little light, it will be found that small light sources are required. In residence lighting, cases are very unusual where light sources of mean spherical candle-power greater than 20 c-p. can be used without considerable sacrifice in efficiency. A light source of mean spherical candle-power from eight candle-power to 10 c-p. has largest application in residence lighting. It is in this feature that the incandescent lamp has its greatest advantage over other illuminants: it is readily obtainable in whatever size it is most efficient for the particular installation.

## VI.

The efficiency of the light source is the third kind of efficiency with which the illuminating engineer has to deal. Efficiency of light source depends primarily upon a single factor—namely,

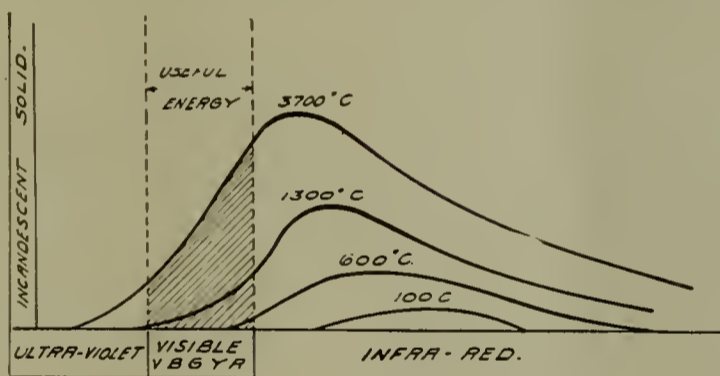

FIG. 2.

More artistic results and better efficiency are obtained when the light comes from clearly marked sources. It should be noted, however, that the application of the previous rule will sometimes require a large number of centers of distribution; for instance, in drafting-room illumination. In such cases the previous rule is paramount.

Several smaller illuminating units adjacently located at the same center of distribution give more efficient effects than a single larger unit. The most suitable number of units for one center of distribution is usually three, four or five.

Do not locate an illuminating unit on wall bracket or closely adjacent to a wall. If wall brackets are insisted upon on account of their supposed artistic effect, a small light source, surrounded by a relatively large diffusing globe, should be used. By this arrangement the so-called artistic effect is attained without introducing any objectionable factors into the illumination. The actual illumination will, of course,

the temperature to which the incandescent light-giving body is raised.

A clear idea of the relation of temperature of incandescent body to efficiency of light generation may be obtained by reference to Fig. 2. The curves here shown are copied from an article by Mr. E. Percival Lewis in the *California Journal of Technology* of April, 1907. The curves graphically show the various steps in the phenomenon of light generation. When sufficient heat is imparted to a body to raise it to a low temperature, say 100° C., the body radiates energy in the form of long period ether waves. These waves are capable of stimulating certain nerves of the skin, and from this we have come to call them heat waves. These waves, it should be noted, have not the power to stimulate the optic nerve. If, now, the temperature of the body be raised to 600° C., a larger amount of energy is radiated, and the radiations are over a broader range of wave-lengths. Some of the shorter of the waves now generated are capable of stimulating

the optic nerve. These waves we call light. Again raising the body to a higher temperature a still large amount of energy is radiated over a still broader range of wave-lengths. The shorter of the waves now produced are incapable of stimulating either optic nerve or nerves of the skin; but these very short waves are especially active in producing chemical changes, and hence they are sometimes called chemical waves. It will be noted that as the temperature rises and the total amount of radiating energy increases, the increase is chiefly in the shorter wave-lengths. Hence the proportion of light waves to total wave energy, or, in a word, the efficiency increases as the temperature increases.

The curves apply equally to any incandescent solid whatever its chemical constitution. They therefore apply to all light sources in practical commercial use except the mercury vapor and other vapor lamps.

Every body or material has, however, its own fairly well-marked limiting temperature beyond which, if it is raised, the structure of the body rapidly deteriorates. Carbon, for instance, when heated in vacuum, throws off minute carbon particles very rapidly at temperatures above 1800° C. This, therefore, is the temperature which limits the efficiency of the carbon filament incandescent lamp.

Fortunately, in the case of both gas and incandescent lamp light sources, materials have been found which will withstand high temperatures without rapid deterioration. The gas mantle is too well known to need comment, but at its introduction it marked a tremendous advance in efficiency of light sources. Now a still greater advance has been made by the development of methods of preparation of various metals, of which tungsten stands first, for use as the filament of the incandescent lamp. Tungsten may be raised in vacuum to a temperature of at least 2300° C. without the occurrence of rapid deterioration. This increase in temperature from 1800° C. to 2300° C. represents an increase in efficiency of two and one-half times.

A short digression from the subject proper of this paper is, I trust, permissible, in order to bring out certain salient features of the new high-efficiency tungsten lamp.

Fig. 3 shows the relative light distribution of carbon filament and tungsten filament lamps when burning at equal wattage. The carbon filament lamp is burning at 3.1 watts per mean horizontal candle, the tungsten filament lamp at 1.25 watts per mean horizontal candle.

Table II shows the comparative efficiency of the tungsten lamp among other electric illuminants. This table, with the exception of the value for the tungsten lamps, is taken from Cravath and Lansing's *Practical Illumination*. Values for the tungsten lamp were obtained from tests made in the laboratories of the Westinghouse Lamp Company, and are correct for the type of lamp tested to within + or - 3 per cent.

The brittleness of tungsten is so extreme that it seems at present very improbable that lamps of lower candle-power than 25 mean horizontal can ever be commercially made for operation on 110-volt circuits. At the present state of development, the commercial practicability of a lamp of lower candle-power than 40 has not

lamp can be produced with filament strong enough to withstand shipment with small percentage of breakage.

The tungsten filament lamp, on ac-

TABLE II

All values involving candle-power are expressed in terms of mean spherical candles.

Kind of Lamp	Mean Spherical Candle-Power	Watts per Candle	Amount of Light per Kilo-Watt Hour
Common 56 watt carbon filament incandescent lamp rated at 3.5 w. p. c.; 16 horizontal c. p. . . . .	13.2	4.24	236
Common 50 watt carbon filament incandescent lamp rated at 3.1 w. p. c.; 16 horizontal c. p. . . . .	13.2	3.78	264
3-glower 264 watt Nernst lamp . . . . .	81.0	3.26	307
High-efficiency Gem 125 watt graphitized carbon filament lamp of 50 horizontal c. p. . . . .	40.7	3.07	326
44 watt tantalum lamp 22 rated horizontal c. p. . . . .	16.0	2.75	364
Direct current 5.1 amperc enclosed arc on 110 volt circuit, 0.5 inch carbons . . . . .	213	2.63	380
Alternating current enclosed 5.7 amp. arc taking 388 watts on 110 volt circuit 0.5 inch carbons . . . . .	152	2.55	392
Tungsten 60 watt 1.25 w. p. c. 110 v. lamp . . . . .	37.0	1.62	641
Luminous 8 amp. arc, 440 watts, 2 in series on 110 volt circuit . . . . .	1020	0.431	2320

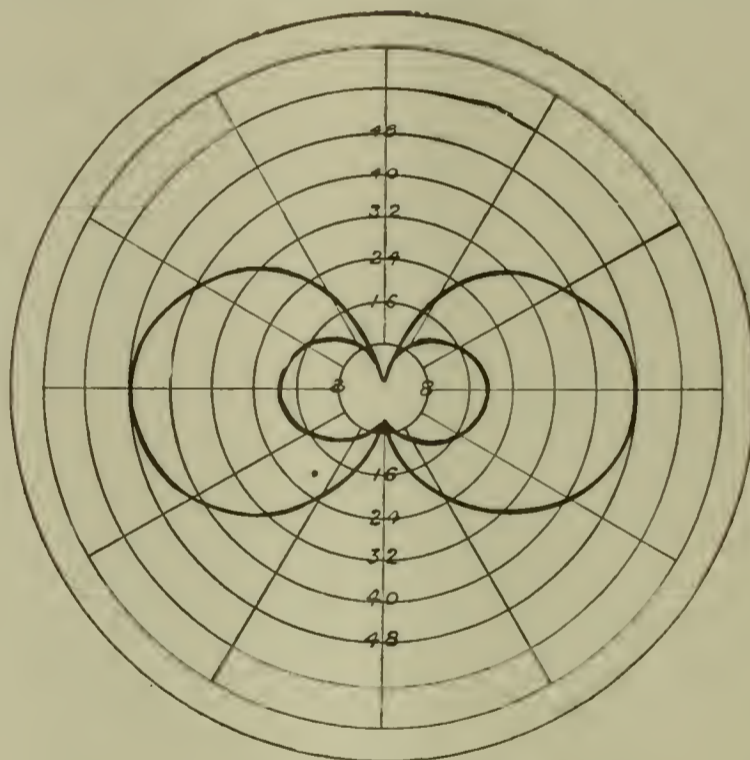

FIG. 3.

been fully proven. The 40 c-p. lamp, or even the 25, is too large a unit for most residence lighting. At present writing it seems very probable that for residence lighting some plan of circuits will have to be adopted so as to give available voltages of 25 volts or 50 volts across the lamp terminals. At 25 volts a 10 c-p. (mean horizontal)

count of the positive temperature coefficient of tungsten, is very much less injured by variations in voltage than the carbon filament lamp. Double voltage may be thrown across the terminals of the tungsten filament lamp without causing immediate burn-out, the average lamp burning at such double voltage for over an hour.

# Downward Versus Horizontal Illumination

THE author of the article entitled "Downward Illumination" in the March issue of THE ELECTRICAL AGE has taken a wrong, though a popular, point of view in considering the advantages of the "downward light" lamps that have been put on the market. He shows curves which indicate the well-known fact that the flattened coil and spiral filament lamps give a higher tip candle-power than do the ordinary oval anchored carbon or the tantalum filament lamps. He then endeavors to show why these "downward light" lamps should replace the ordinary types when a strong illumination is needed directly under the lamp, leaving almost out of consideration the use of proper reflectors.

The "downward light" lamps get their downward distribution on account of having a large part of the filament arranged approximately horizontal. They can be designated, then, as "horizontal filament" lamps as opposed to the ordinary, or we may say, the "vertical filament" lamps. Let us consider the distribution curve of one of these horizontal filament lamps (Fig. 1). This is the curve for a spiral filament. It shows the charac-

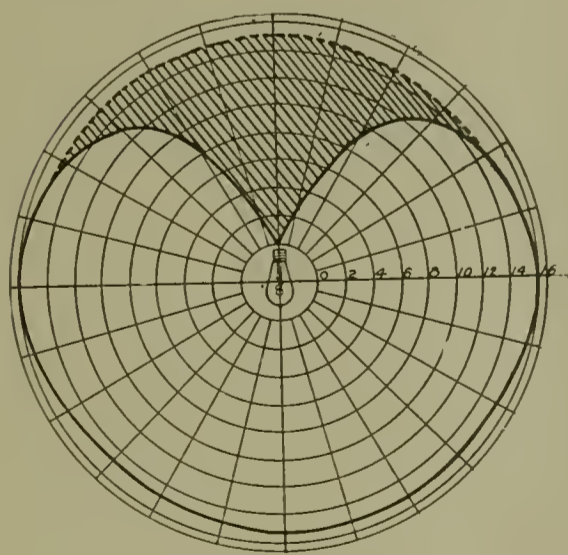

FIG. 1.

teristic high candle-power in the downward direction, obtained by the approximately horizontal arrangement of the filament. Since the filament must emit light equally in all directions normal to its surface, there must be the same intensity of light emitted

downward as upward. Most of the light radiated upward from the horizontal portions of the filament is lost in the base by absorption. If it were not for the presence of the stem and the base of the lamp, the distribution curve would be almost symmetrical on both sides of the horizontal axis, since the filament is approximately symmetrical. Let us now draw a dotted curve above the horizontal to correspond with that half of the distribution curve below, thus making it symmetrical. Now from the area (shown shaded) between this dotted curve and the curve of distribution above the horizontal, we get an indication of the amount of light that is lost in

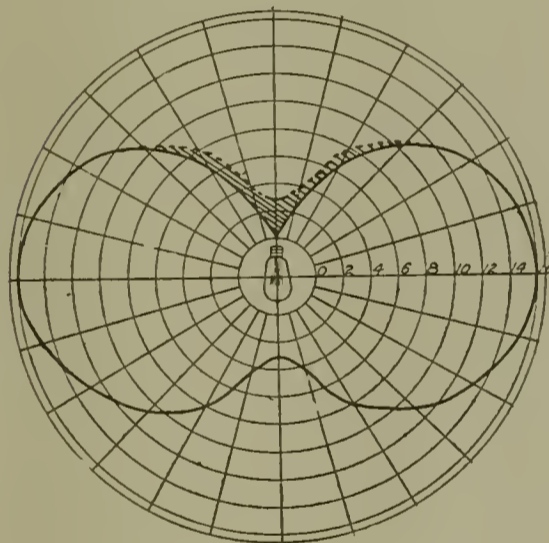

FIG. 2.

the base of the lamp when this shape of filament is used. The area is large, indicating a large loss.

The curve in Fig. 2 represents the distribution about the tantalum lamp, one of the most pronounced types of the vertical filament lamps. Here there is a low tip candle-power indicating that but little light is thrown downward and upward. When the dotted curve is drawn as it was with the horizontal filament lamp the area enclosed is very small, indicating a very small loss of light in the base. Hence, for a given watt per candle consumption the bare vertical filament lamp would be more economical than the bare horizontal filament lamp. The horizontal filament lamp has, however, the advantage in the fact that its distribution is more often de-

sirable than that of the vertical filament lamp.

A bare incandescent electric lamp having a filament of whatever shape is very seldom a proper lighting unit. Hence, to get a proper distribution, both sorts of lamps will often require the use of reflectors. Near the base of a lamp all light that has its course changed downward by reflectors must strike the reflector at a large angle. This, of course, is a condition that favors absorption losses in the reflector. With the vertical filament lamp the radiation in these unfavorable directions is less than in the horizontal filament lamps, and is superior for that reason when reflectors are used.

The case of the horizontal filament lamp, then, may be stated as follows: (1) It gives in some instances a distribution approximately that desired; (2) this distribution is obtained at the cost of a considerable loss of light in the base; (3) if it is desired to change its distribution by means of a reflector, light of fairly high intensity must strike the reflector at large angles, which is a condition favoring absorption losses. In regard to the vertical filament lamp it is observed: (1) It gives in few instances the distribution that is desired; (2) there is little loss of light in the base, because little of the filament is horizontal; (3) when the distribution must be changed by a reflector there is little light that strikes the reflector at large angles and then it is of low intensity, thus giving low absorption losses in the reflector. When one considers the fact that the best reflectors are inexpensive, that they can be obtained to give any desired distribution and that they greatly enhance the beauty of the light a vertical filament lamp equipped with a reflector seemed a much better proposition than a horizontal filament light of the same watt per candle consumption either with or without a reflector.

T. H. AMRINE.

This communication was received too late in the month for us to make a reply. Next month we shall publish a full answer to Mr. Amrine's criticism.—ED.

# Electric Locomotives—Concluded

H. L. KIRKER

THE electric locomotive is not only more economical than the steam locomotive, but it is simpler. It is equally as reliable, and gives a smokeless service. These are important factors in the question of substitution of the electric for the steam service. The advisability of substitution, however, does not directly concern us here. It is a question that the management has already settled, so far as the St. Clair Tunnel is concerned, or I would not be talking to you this evening. The interesting fact is that alternating-current locomotives are substituted. Our concern, then, is to get a working notion of alternating electric currents.

## DIRECT CURRENT VS. ALTERNATING CURRENT.

I pointed out that the speed characteristics of the series motor, the economic advantage of electric traction and the desirability of smokeless service are commercializing the electric locomotive. There are no indications, however, that the direct-current locomotive will eliminate the steam locomotive from main-line work. The trolley-voltage limit settles that point. There are but few traction systems that operate direct-current motors on a voltage greater than 650 volts. There have been many improvements in motor design within the last ten years, but the voltage limit seems to remain about 650 volts. Heavy power, we know, cannot be transmitted long distances economically with such a direct-current trolley voltage as this, even if special means of generation and transformation are resorted to. I also pointed out that there is a considerable waste of energy every time the direct-current motor starts. Then there is the electrolytic effect of direct current. You know that direct current has a dissolving effect on metal pipes at points where the current flows from the pipes into moist earth. Minute particles of the metal seem to travel along with the current at these points. The tracks usually constitute an important part of the return circuit. It is not surprising, then, that we find in the large urban systems that some of the current strays from the proper returns and finds its way to gas pipes and water pipes and thence into earth, as the current makes its way back to the station. The damage these stray direct currents do to these pipes is sometimes serious.

The natural solution of the electrolysis problem is, of course, to neutralize this dissolving tendency. Suppose our current instead of being continuous is a rapidly alternating one. We can readily imagine that the minute particle of metal that is caught up by the current and carried to earth is immediately returned to the pipe a fraction of a second later when the current reverses and flows from the earth to the pipe. When a 25-cycle current is used the same particle will travel back and forth 25 times per second. Had continuous current been used, why 25 particles of metal would have been permanently transferred each second from the pipe to earth. In fact, we know from experiment that the electrolytic effect of alternating current on iron pipes is negligible. Consequently, if we can make our series motor work satisfactorily on alternating current we can, by the use of alternating current, eliminate the electrolysis of gas and water pipes.

But will the series motor work on alternating current? A glance at the diagram settles this, for we know that if we reverse the field current alone we reverse the direction of rotation; also, that if we reverse the armature current alone we reverse the direction of rotation, but if we reverse the field current and armature current simultaneously, why the direction of rotation is unchanged. Reversing the line current must reverse the field and armature current at the same time, so does not affect the rotation (refer Fig. 25). So far as the series motor is concerned, then, we can use either direct or alternating current.

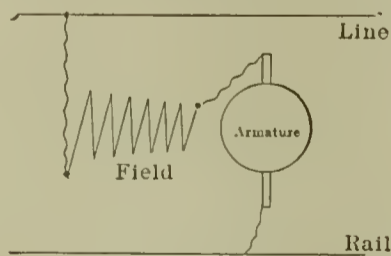

FIG. 25.

You know, of course, what alternating current is—that 25-cycle current, for instance, flows alternatingly out through the trolley and back through the rail, then out through the rail and back through the trolley, 25 times in each direction per second. If it flows alternatingly 60 times in each direction per second it is 60-cycle current. You also know that, by the use of induction coils, alternating current can

be raised to a high voltage and likewise, by the use of induction coils, it can be reduced to low voltage again. This induction feature makes possible the economical transmission of alternating current over long distances. Moreover, we shall see presently that the same induction feature enables the alternating-current series motor to eliminate the losses incident to starting the direct-current motors.

Alternating current is the kind that Faraday discovered. It is the kind you get by moving a wire back and forth across a magnetic field. You will recall that a commutator had to be devised to make the current flow continuously in the same direction in the line to which the armature is connected. Now the simple alternating current, or single-phase current, as it is called, seems to solve the electrolysis problem, extend indefinitely the range of economical transmission and minimize the starting losses. These three facts mean that the alternating-current series motor has a vast field of usefulness before it. However, this simple alternating current, which is so easily produced and which so easily induces other alternating currents, has been a long time in coming to the front as a suitable current for traction purposes. It has been split up into two-phase and three-phase currents. The three-phase current is almost universally used for long-distance transmission and for constant-speed motor work. There has been no difficulty in producing alternating currents, single-phase or polyphase, nor has there been much difficulty in producing a constant-speed polyphase motor. They have all been in use for a long time. The problem has been to develop a variable speed motor that will start on a single-phase current. The solution of this problem involved the proper handling of the induction effects that are always possible with alternating current. Years of experience in operation and design have finally solved the problem, and we now have a single-phase series motor that can compete with the direct-current motor. The single-phase series motor is the kind you will have on the tunnel locomotives. So far as we are concerned, we can consider your motors as direct-current series motors. What I want to especially direct your attention to is the induction property of the alternating current. It is easily understood in the terms of Faraday's discovery.



ALTERNATOR-TRANSFORMER SINGLE-PHASE LOCOMOTIVE.

I just stated that it is an easy matter to produce alternating current. We can get it from our direct-current armature by tapping the winding at two diametrically opposite points, and connecting tap No. 1 to an insulated slip ring on the armature shaft, which slip ring is connected to the trolley wire by an insulated brush, and then connecting tap No. 2 to another similar slip ring which is connected to rail in the same way as No. 1 is to trolley (see Fig. 26). Assume that the direction of the field and the direction of rotation is to be the same as before. Consider what is going on when tap No. 1 is in the top position. We see that current is flowing up both halves of the armature winding and out through tap No. 1 to the trolley, thence down through the motor and back through the rail to tap No. 2. Now a half revolution later tap No. 2 is on top and we see that the current is flowing up through both halves of the armature winding and out through tap No. 2 to rail, thence up through the motor and back through the trolley to tap No. 1 (see Fig. 27). Another

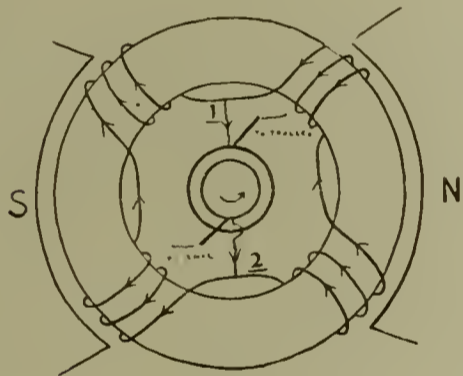

FIG. 26.

half revolution brings tap No. 1 on top again, and the armature currents, which are always flowing up, flow out through the trolley again. So the current goes on reversing, making a complete cycle for every revolution of our armature. The same armature could supply direct current through the commutator to one circuit at the same time that it supplies alternating through the slip rings to another circuit. It could also run as a direct-current motor and supply alternating current through the slip ring, or run as an alternating-current motor and supply direct through the commutator. You know that this latter arrangement is used in street railway work for changing alternating current into direct current. Such a machine is called a rotary converter. When acting as a rotary converter, however, the machine is usually supplied with three-phase current. I will remark in passing that we can get three-phase current by tapping our armature

winding at three equidistant points. Three slip rings and three line wires are required (see Fig. 28). We see that when tap No. 1 is on top the current flows out wire No. 1 and back No. 2 and No. 3. When No. 2 is on top the current flows out No. 2 and back No. 3 and No. 1, and when No. 3 is on top the flow is out No. 3 and back No. 2 and No. 1. However, when single-phase motors are used direct current is not required, so the rotary converter is eliminated, and, consequently, the three-phase current is unnecessary.

So much for the alternator; but how about the induction coil, or transformer, as it is called? Well, it is based on Faraday's discovery that cutting lines of force induces a voltage, and on the further fact that voltage varies with the rate of cutting. Suppose we wind 1000 turns of insulated wire on an iron ring and connect the ends to an alternating-current circuit (see Fig. 29). When the current is flowing into the top end of the coil the direction of the magnetism in the ring is down through the coil. When the current is flowing into the bottom end of the coil the direction of the magnetism in the ring is up through the coil. When the current is zero there is no magnetism in the ring. Consider loop No. 1 when the current begins to flow. The incipient rings of magnetism dilate until they lie completely in the iron circuit. As they dilate they cut across all the loops. Likewise, the magnetism due to the current in coil No. 2 cuts across 999 loops. So does the magnetism of loop No. 3. So does the magnetism of every one of the 1000 loops. We see, then, that each loop is cut by the magnetism due to 999 loops. Now as the current dies away the rings of magnetism contract and disappear,

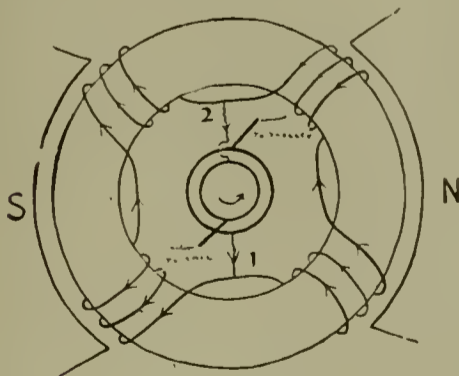

FIG. 27.

and in doing so cut across the loops again, but in the opposite direction. The greater the total magnetism and the greater the number of reversals per second, why the greater the voltage induced in each loop. In other words, the greater the rate of cutting done by each loop, why the greater the voltage induced in the loop. We can assume in this case that the num-

ber of lines is such and the frequency is such that each loop generates one volt. The combined voltage of the 1000 loops then is 1000 volts. This voltage set up in the coil by the passage of alternating current through the coil is called the voltage of self-induction.

An examination as to the direction of the voltage of self-induction shows that it is opposed to the current that produces it. We found a similar set of conditions in the motor armature. There the induced voltage opposes the current that rotates the armature. In order that a current may flow, the line voltage must be greater than the induced voltage. We see, then, that the voltage supplied by the alternator must be slightly greater than 1000 volts in order that the alternator may drive a current against the 1000 volts



FIG. 28.

of self-induction set up by the alternating current.

Suppose now that we bring out two taps, so as to include 25 turns. We get 25 volts across the taps. Suppose we tap on so as to include 250 turns. We get 250 volts. We can connect out series motor to these taps (see Fig. 30). These rapidly reversing 250 volts of self-induction will drive an alternating current of the same frequency through our series motor. This current, since it is driven by the voltage of self-induction, will be in opposition to the current from the alternator. At a particular instant, for ex-

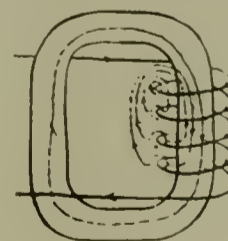

FIG. 29.

ample, the line current will be flowing down through 750 turns, will be opposed by the motor current flowing up through the 250 turns. The two currents will combine and flow out through the top tap to the motor, then down through the motor. The line current will go on into the line and back to the alternator. The current that came from the 250 turns will flow back through the bottom tap into the 250 turns again.

We have just seen that the motor current is in opposition to the line current, consequently, it will have a demagnetizing effect on the iron ring. This diminution in the magnetism will cut down the voltage of self-induction. This will allow a bigger current to flow from the line. The increased line current, however, is not sufficient to return the magnetism to its former value, for if it were the voltage of self-induction would regain its former value and the bigger current could not continue to flow. If we increase the load on the motor we draw a heavier current from the 250 turns, and accordingly wipe out still more of the magnetism in the ring, which allows a still bigger line current to flow. So the line current will go on increasing as the load on the motor increases. There is a definite ratio between the line current and the motor current. In the case where the motor is taking, say, 200 amperes at 250 volts, the alternator delivers 50 amperes at 1000 volts. The ratio is 1000 to 250, or four to one. Now if our coil had 10,000 turns the ratio would be 40 to one. So when the motor takes 200 amperes at 250 volts, the alternator gives five amperes at 10,000 volts. As we increase the voltage we must also increase the quality of the insulation. There is no special difficulty in getting a high voltage, say 75,000 volts, but there is great difficulty in finding an insulator that will stand up indefinitely against such a pressure. However, lines employing 60,000 volts are in use. Now the generator voltage need be only one-tenth of the line voltage, for transformers can run up the voltage as high as desired. The motor voltage need be only 250 volts, for transformers can cut the line voltage down as desired.

You will note here that we can, by tapping the transformers at successive points, get the graduated voltage required for starting the motor, and accordingly eliminate the rheostatic losses.

Now we can wind two coils on the same ring, and, as we have just seen, can, by sending an alternating current through one coil, induce an alternating current in the other. If one of these coils has 1000 turns and the other 60,000 turns and the proper amount of iron is in the circuit we can, by applying 1000 volts to the 1000 turns, get 60,000 volts from the 60,000 turns. Consequently, we can, with such a transformer, use a 1000-volt dynamo and get a 60,000-volt feeder pressure. Likewise, if we had another transformer of the ratio of 60,000 to 10,000, we could step down from a feeder pressure of 60,000 volts to a trolley pressure of 10,000 volts, and

with the auto transformer could step down from a trolley pressure of 10,000 volts to a motor pressure of 300 volts, or 200 volts, or 100 volts, or 50 volts—in fact, we could get whatever pressure was required for running or starting the motor. Assuming, for simplicity, that there are no losses in the transmission and that the motor requires 90,000 watts, we see that the generator will deliver 90 amperes at 1000 volts to the step-up transformer, that the step-up transformer will deliver 1.5 amperes at 60,000 volts to the transmission line, and that the line will deliver 1.5 amperes at 60,000 volts to the step-down transformer, which will deliver nine amperes at 10,000 volts to the trolley, which will deliver nine amperes at 10,000 volts to the auto transformer, and if the motor is built for 250 volts the output of the auto transformer will be 360 amperes at 250 volts.

The alternating current, as stated,

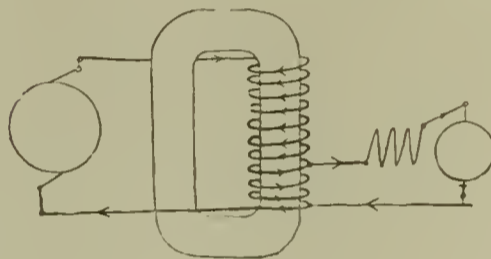

FIG. 30.

will have no appreciable electrolytic effect. The single-phase series motor then is a solution of the electrolysis problem, a solution of the starting-loss problem and a solution of the trolley-voltage limit problem. It would seem then that the single-phase locomotive is almost ideal, and that it will have an enormous field of usefulness. However, the evolution of a commercial single-phase motor has taxed the talent of the designing engineer. We have just seen that alternating current tends to induce counter-currents. The problem of the designing engineer has been to keep these induction effects within the danger limits. If alternating current were applied to the ordinary series motor, why the induced currents would burn out the motor in short order. The motor must be so designed as to minimize the voltage of self-induction, and minimize the currents due to the induced voltages. These induced currents generate heat. These heat losses are in addition to the losses incident to the direct current. The total losses of the alternating-current motor, then, are greater than those of the direct-current motor, and if the heat due to the total losses cannot be radiated as fast as they are generated, why the motor will eventually burn up. However, the skill of the designing engineer has finally triumphed, and we now have

an alternating-current series motor that can compete with the direct-current motor.

The single-phase locomotive, then, is a special case of the direct-current locomotive. The motors are series wound, but they are so designed that they minimize the induction effects of the alternating current. The starting rheostat of the direct-current motor is replaced by the auto transformer. The controlling device for operating the switches is essentially the same as that used with direct current. The trolley arrangement is the same except that it is insulated for the higher trolley voltage. The brake rigging is the same. The single-phase locomotive, then, when approached from the standpoint of the steam locomotive and of the direct-current locomotive, is a simple affair after all.

#### LAG.

There is just one more point at which you should glance before we finish our remarks on alternating current; it is the effect this self-induction has on the time relation of the main voltage to the main current. You know that our hottest days come after our longest days. Well, in a circuit in which there is self-induction the heaviest current drags behind the heaviest voltage and the amount of the lag varies with the nature of the load, the nature of the circuit, etc. However, you do not need to worry about this, but if you will bear in mind that when a current is a rapidly reversing one, it will produce self-induction in any coil in the circuit, and the effect of the self-induction will be to make the time of the maximum current lag behind the time of the maximum voltage, and you will see that the power at any instant is the product of the instantaneous current by the instantaneous volts. So, if, when the voltage is maximum, the current is only 80 per cent. maximum, the actual energy of the circuit is only 80 per cent. of the product of the maximum current by the maximum volts. The presence of self-induction then complicates the measurement of alternating-current energy. But that does not concern us here. Knowing that self-induction and lag exist does not involve the necessity of your measuring them.

It is essential, however, to measure the power the alternating-current locomotive takes to do its work. The watt meter will measure it for us. The watt meter is a diminutive motor whose speed is proportional to the power in the main circuit. It is so designed that its field strength is proportional to the line voltage, and its armature current to the line current. It will accordingly respond to varia-

tions in either, and measure the instantaneous product of both. The little motor is the accountant that charges up the locomotive with its drafts on the power-house. It represents the commercial aspect of the case. It is the tell-tale that ultimately decides the fate of the machine. It is the final check that is applied to the industrial application of Faraday's discovery. Having arrived at the meter, we have reached the point where we can measure the power consumption of the single-phase locomotive, and that is as far as we need to go.

#### SUMMARY.

I have given you no details as to the electric locomotive, nor is it my intention to do so. You will find such technical descriptions in the trade journals, and there will be plenty of specific articles dealing with your particular locomotive. What you want is a grasp of the general principle that pervades the machine. You know that knowledge is increasing discrimination. Consequently, if you understand the functions of the locomotive and add to that a mental picture of current-producing motion, and a mental picture of motion-producing current, why it is only a question of easy discriminating steps to arrive at the specialized case of the single-phase locomotive. As I have pointed out, it is mainly a question of patience. A single principle will explain a multitude of facts. The economical method, therefore, is to capture the principle instead of laboriously memorizing the facts. Now I have aimed to blaze the trail and have tried to make it a straight one. It is not a short one, but like any other path, the more often it is used the easier it is to follow. I do not know of any short cut. Locomotive work is our subject and the work must be measured. The magnetic properties of the electric current are the basis of the motor, consequently, induction must be understood. The commutator is a practical means of securing continuous armature rotation in a magnetic field, so it must be clearly understood. The rotation of the armature in the magnetic field sets up a voltage in the armature, consequently we must discriminate between the conditions incident to operation as a motor and operation as a dynamo, and see that the same current which makes the motor armature push also makes the dynamo armature drag. We also get a quantitative notion of the relation of voltage to speed, and combine this with the quantitative relation of current to torque in order to be able to understand that the product of current by volts means power. Knowing that current produces heat we must find a means not only of

measuring the heat, but of calculating the current, the resistance through which the current flows, and the voltage required to drive the current through the resistance. Having found out how to translate electric energy into terms of heat we must trace the chain of transformation from the coal to the motor in order that we may compare the performance of the electric locomotive with the steam. Since the series motor gives the electric locomotive the same speed and draw-bar characteristics as the steam locomotive, we must understand the series motor. Having compared the steam locomotive and the direct-current locomotive and discovered the limitations of direct current and the possibilities of alternating current, it is necessary for us to know how alternating current can be produced, transmitted, applied and measured, in order that we may know just where the single-phase locomotive stands with reference to the steam locomotive. Having arrived at that point, we have achieved the object of our talk—to put the electric locomotive before you as an understandable commercial machine.

#### Long Acre Company Hearing

The Public Service Commission, in its investigation of the electric light companies of New York, held a meeting March 12th to look further into the affairs of the Long Acre Co. Walter H. Knight stated that, of the total issue of \$1,000,000.00 worth of 4 per cent. bonds, \$500,000.00 had been sold and \$100,000.00 hypothecated as collateral with The American & British Mfg. Co. Mr. Knight stated that this company had been given a formal order on July 3, 1907, to perform all work and labor in connection with the proposed Long Acre plant at the actual net cost, as shown by vouchers presented to and duly approved by the general engineer of the Long Acre Company, plus a profit of 15 per cent., the Long Acre Co. agreeing to surrender \$100,000.00 of the face value of its bonds to the American & British Co. for the performance of its terms of the agreement.

During the year 1907 the Long Acre Co. had no receipts, and its expenditures were mostly for incorporation matters.

Henry W. King, as counsel for the Long Acre Electric Light & Power Co., stated in response to an inquiry respecting the books of the American Electric Illuminating Co. that he had traced the books of said company into the hands of John M. Ward, its receiver, but that Mr. Ward was dead and he was unable to trace the books further. He failed to find the books

of the American Electric Manufacturing Co. The question being raised as to whether the American Electric Illuminating Co. had operated its franchises prior to July 1, 1907, Mr. King stated that this company operated a plant in a building on East 25th Street at Avenue A, with 250 arc-light dynamos, stringing wires down Avenue A to Houston Street in 1889.

The Long Acre Co. franchise was granted to the American Electric Mfg. Co. in 1887, was assigned in 1888 to a Mr. Townsend and in 1889 was assigned by him to the American Electric Illuminating Co. In consequence of a judgment obtained against that company by a Mr. Dalton in 1897, the property was sold at auction to a Mr. Minturn for \$100.00, the only property being found to be the company's franchise. In 1896 Mr. Minturn turned the franchise over to the Long Acre Electric Light & Power Co. The franchise is perpetual and applies to the City of New York as it was organized in 1887, which included the present Borough of Manhattan and the portion of the Borough of The Bronx west of the Bronx River. One of the stipulations of this franchise was that one arc lamp was to be supplied to the city free for every 50 arc lights furnished to other customers, and Mr. King contended that the American Electric Illuminating Co. had fulfilled this stipulation, but admitted that it had not paid a cent per lineal foot for the streets which it occupied under the city permit.

An attempt on the part of Commissioner Maltbie to elicit information regarding the real ownership of the company and the 490 shares of stock voted by Mr. Bouchie, only elicited information that Mr. Bouchie was the trustee for the Manhattan Transit Co., and that the other 10 shares of stock were held by individuals for the purpose of qualifying them as directors.

Mr. Knight, being recalled to the stand, stated that the Long Acre Co. had been engaged since January, 1908, in constructing a small central power plant and placing ducts leading to the conduits in the streets, and that it is now engaged in making subsidiary connections to its customers. The power plant is located on Second Avenue and Forty-seventh Street. The only customer connected at the time of the hearing was the Manhattan Transit Co., whose bills run from \$400.00 to \$500.00 a month.

Mr. Knight stated that the company was planning a storage battery station and was carrying out plans for a large Waterside station, and that they had an offering of the lamp load of the Criterion Theater when its present

contract expired. The relationship between the Manhattan Transit Co. and the Long Acre Co. is that the Manhattan Transit Co. owns 98 per cent. of the capital stock of the Long Acre Co. and that the plant of the Long Acre Co. is located on the property of the Manhattan Transit Co., from which it leases room.

Mr. W. H. King, on being recalled, gave the following inventory of the property of the Long Acre Light & Power Co., as of February 1, 1908:

- 2 75-h.p. Diesel oil engines.
- 1 5-panel main switchboard.
- 2 6-in. kw. generators.
- 6 Wattmeters.
- 1 10,000-gal. oil tank.
- 2 10-h.p. motors and regulators.
- 1 5-h.p. motor and regulator.
- 1 1/2-h.p. motor and regulator.
- 1 lot of encased fuses.
- 1200 ft. No. 0 lead-covered cable.
- Wiring and connections to cable.  
\$16,000.00.
- Cash in treasury, \$18,010.24, making a total of \$34,010.24.

On being questioned as to the advantage arising from competition to be introduced by his company, Mr. King stated that the consumer naturally profits by competition; that his company could sell electricity at a less price than the commonly prevailing price in New York. He did not consider it at all likely that there would be an agreement between the two companies to fix prices. Mr. King admitted that it was possible for the Consolidated Gas Co. to acquire a controlling ownership which would eliminate competition.

#### Legal Notes

##### TELEGRAPH COMPANY'S RIGHT IN HIGHWAY.

A telegraph company obtained from a bridge company the right to lay its cables and wires across the bridge for an annual rental. Thereafter the bridge was acquired by the county in which it was situated. *Held*, that the county could not compel, by a suit in equity, the telegraph company to remove all wires and cables or pay rental for the use of the bridge; it having adequate remedy at law in an action to recover damages for the use while no compensation was paid. *Beaver County v. Central Dist. & Print. Tel. Co.* Supreme Court of Pennsylvania. 68 Atlantic 846.

##### DEATH BY SHOCK—INSUFFICIENT COMPLAINT IN SUIT.

Under Rev. St. 1895, art. 3017, subd. 2, giving a right of action for wrong-

ful death, a complaint in an action for death against a corporation furnishing electric power for domestic, etc., purposes, which alleged that while decedent, an employee of one of defendant's customers, was repairing an electric wire, defendant's engineer negligently and contrary to his agreement with decedent turned on the current, thus causing decedent's death, but which did not allege that defendant failed to exercise due care in selecting a competent engineer, or that it was negligent in the selection of its machinery or in the construction of its poles and wires, did not state a cause of action. *Williams v. Northern Texas Traction Co.* Court of Civil Appeals of Texas. 107 Southwestern 125.

##### CITY LIGHTING PLANT—SAFETY.

Where the wires connecting with a city lighting plant ran along a partition wall above the roof of a building, it was the city's duty to the owners of the buildings and their servants, and to others having a legal right to use the roofs, to maintain such wires in a safe condition. *City of Greenville v. Pitts.* Supreme Court of Texas. 107 Southwestern 50.

##### LOCATION OF TROLLEY POLES.

Where an electric railroad company is authorized by a city to locate trolley poles along a street, they are not nuisances; but such permission does not authorize the company to locate its poles so as to unduly and unnecessarily interfere with the public use of the streets, or with the use of proper ways of ingress and egress to and from the street by abutting owners. *Lambert v. Westchester Electric Ry. Co.* Court of Appeals of New York. 83 Northeastern 977.

##### TURNING ON CURRENT AFTER NOTICE THAT WIRE WAS DOWN.

Without regard to the respective contentions of the parties as to the proximate cause of the electric light wire being down across the street which the plaintiff was traversing at the time that he came in contact with it, and was injured by the electric current with which it was charged, the jury could have found from the evidence that the proximate cause of the plaintiff's injuries was negligence on the part of the defendant in turning on such electric current, after receiving actual notice that the wire was down, and without taking any steps to remove the dangerous situation which existed by reason of its being down. *Mayor of Madison v. Thomas.* Supreme Court of Georgia. 60 Southeastern 461.

##### REGULATING PUBLIC SERVICE CORPORATION.

Though the power to establish a tariff of rates for a public service corporation is legislative, and not an executive or judicial function, the Legislature may delegate the right to fix rates for a specified service to an administrative body to conform to a standard established by the Legislature, especially where it appeared that no uniform rate of charges could be established throughout the State that would be just or reasonable, and that an approximation of a reasonable tariff would require special rates to be prescribed for many different localities. *Village of Saratoga Springs v. Saratoga Springs Gas, Elect. Lt. & P. Co.* Court of Appeals of New York. 83 Northeastern 693.

##### ESTABLISHMENT OF ELECTRICITY COMMISSION NOT INFRINGEMENT OF LEGISLATION.

Laws 1905, p. 2092, c. 737, establishing a commission of gas and electricity, and authorizing it to fix, after hearing, within the limits prescribed by law, the maximum price for gas and electricity furnished by any public-service corporation, is not a violation of the federal Constitution guaranteeing to every State a republican form of government, in that it assumes to delegate legislative powers to an administrative body; the true meaning of the constitutional division of governmental power being that the "whole" power of one of the three departments of government shall not be exercised by the same hands which possess the "whole" power of either of the other departments, there being no objection to the imposition on an administrative body of some powers legislative in character. *Village of Saratoga Springs v. Saratoga Gas, El. Lt. & P. Co.* Court of Appeals of New York. 83 Northeastern 693.

##### DUTY OF CITY TO KEEP WIRES SAFE.

Where plaintiff, a police officer, went on the roof of a building in the nighttime to detect persons violating the law, without the owner's knowledge or consent, he was at most a licensee, and could not recover against the city for injuries received from contact with an improperly insulated electric wire belonging to the city, since it was under no duty to plaintiff to keep the wires in a safe condition. *City of Greenville v. Pitts.* Supreme Court of Texas. 107 Southwestern 50.

### A New Type of Induction Motor

The flexibility and economy of the alternating current method of power distribution has led to its almost universal adoption in central station service, and because of the economy of the use of this central service many industrial plants are now purchasing power. The same features that led to the selection of alternating current generation and distribution for central stations have, in a somewhat lesser degree, led to its distribution for large industrial works. On account of this it was necessary to provide alternating-current motors of varying characteristics. The earlier polyphase motor was of the brushless or squirrel cage type and compared more nearly with the shunt-wound direct-current motor. To meet the varying conditions imposed by high starting torque with a low initial starting current, a modified form of motor has been produced by the Westinghouse Elec-

trical & Mfg. Company known as the type HF. The brushes are liberally proportioned, so that they have long life and require the minimum of attention. The rotor is unlike the usual short-circuited type of armature on induction motors, and has a regular winding in which the resistance is inserted while starting, and thus the starting current is limited. Approximately full load current is required to produce full load starting torque.

Special covers are provided for enclosing the brushes where this may be desired. The illustrations show the method employed with the semi-enclosing covers by which the brushes and slip rings are protected from any coarse particles, and the totally enclosing covers which prevent all dust from lodging on these parts.

Type HF motors are built in the usual sizes from 5 to 500 h.p., with

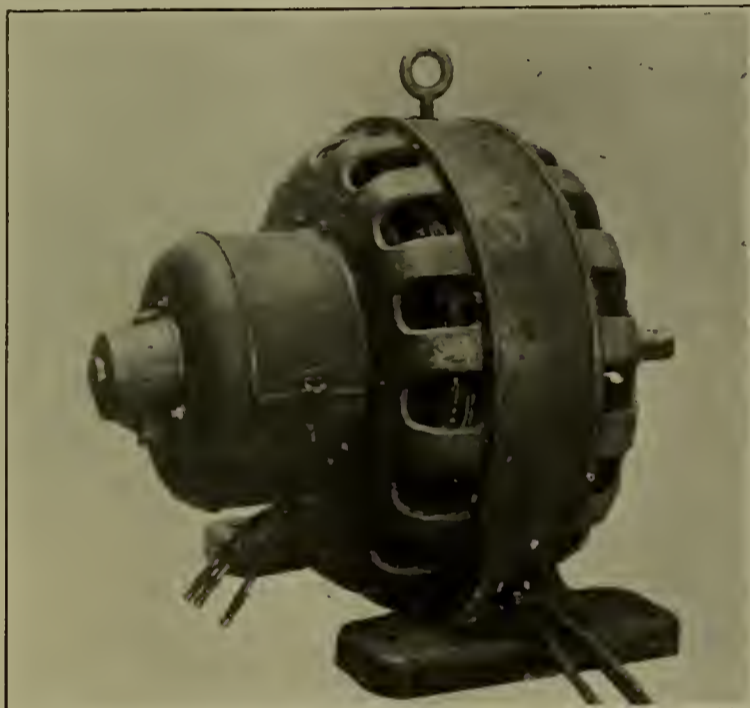

FIG. 3.—HF MOTOR WITH BRUSHES TOTALLY ENCLOSED.

trical & Mfg. Company known as the type HF.

The general appearance of this motor is shown in the illustration, from which it will be noted that it is especially rugged and substantial. The frames are amply ventilated, but so constructed as to protect the laminations from injury. Throughout, the motors have been designed for hard service. The insulation on the coils has been very thoroughly made and will stand much greater stresses than it receives in normal service. It is furthermore so built that vibration, and consequent wear of the insulation, is prevented.

Attention is called to the brushes shown in the illustration, by means of which connection is made to an external resistance. These bear on con-

tinuous rings of metal so that there is no occasion whatever for sparking. The brushes are liberally proportioned, so that they have long life and require the minimum of attention. The rotor is unlike the usual short-circuited type of armature on induction motors, and has a regular winding in which the resistance is inserted while starting, and thus the starting current is limited. Approximately full load current is required to produce full load starting torque.

In connection with these motors, special starting devices are supplied by which the current at starting is varied by hand. These starters cut resistance out of the circuit of the rotating armature until the handle reaches the full-on position, when the resistance is all short-circuited and the motor runs with practically the constant speed characteristics of the squirrel cage armatures. A special short-circuiting switch is provided on motors of 100-h.p. or larger if desired. This relieves the brushes and the leads and contacts on the starter, as the windings are short-circuited inside the motor.

### Aids to the Solution of Practical Illuminating Problems

The science of illuminating engineering is as yet in its infancy, and data of value in the laying out of lighting installations are not plentiful. The activity of the General Electric Company in the advancement of the art of illumination is evidenced by its systematic dissemination of information on this subject. Two bulletins recently compiled by the Harrison, N. J., works of the company illustrate the thoroughness with which such subjects are now being treated. These bulletins are valuable primarily to the practical man engaged in planning lighting installations and are also of interest to every central station organization as a whole.

A perusal of these bulletins, Nos. 4561 and 4506 on GEM high efficiency incandescent units and tantalum incandescent lamps, respectively, will convince the reader of their value as aids to the solution of practical illuminating problems. The illumination tables contained in these bulletins are invaluable in such work and contain information hitherto not available. This data leads itself readily to the laying out of lighting installations and will be appreciated by architects, contractors, solicitors, and others daily confronted with the solving of illuminating problems.

In bulletin No. 4566 the tantalum lamp with its high efficiency and long life is specially recommended to central stations as a desirable factor in the reducing of peak load conditions inasmuch as the use of the 40 or 80-watt tantalum lamps gives the customer 25 per cent. more light than the standard 16 or 32-c-p. lamps, and with an expenditure of 20 per cent. less energy on the part of the central station. Thus it is seen that the general satisfaction which attends the use of the tantalum lamp is shared alike by both buyer and seller of current. Stress is laid on the brilliant and attractive quality of light emitted by the tantalum lamps, qualities which make it most desirable for hotels, theaters, cafés, stores and all public buildings.

The use of the table showing the actual amount saved in dollars and cents by the use of these lamps should prove of great value to lighting solicitors as a convincing argument in favor of the more brilliant and efficient tantalum lamps. This table shows that the tantalum lamp at the average lighting rates now in force will save more than twice the initial cost during its average life of 750 hours.

Several pages are devoted to the elucidation of a practical method for the solution of illuminating problems. The illumination table intended for

use in connection with this method is comprehensive for the 80-watt lamps with three types of holophane reflectors, and by interpolation can also be used for the 40-watt and 50-watt tantalum units. Several curves giving the candle-power distribution with different types of holophane reflectors are also shown.

Bulletin No. 4561 contains valuable information in regard to "GEM" high efficiency incandescent units. These lighting units are composed of the "GEM" lamps with varying types of holophane reflectors and are made in 100, 125, 187 and 250-watt sizes. Candle-power values of these lamps are not given, as it is obvious that these values will vary according to the type of reflector used.

The method of solving illuminating problems which was referred to in bulletin No. 4566 is here treated more fully. The subject of illumination in general is taken up and treated briefly. This is followed by a specific treatment of the subject with reference to "GEM" high efficiency units. Assuming the degree of illumination desired, a problem is worked out, reference being made to the illumination tables for the solution.

Two photographs are shown of the interior of a dry-goods store before and after the installation of Gem units. The original installation consisted of six-light electroliers with ordinary 10-c-p. incandescent lamps, placed  $7\frac{3}{4}$  feet from the floor. The Gem installation consisted of 125-watt high candle-power units with bowl holophane reflectors. These units were installed on the ceiling 14 feet above the floor.

### The Bristol Company

The Bristol Company, of Waterbury, Conn., has come under the control of Prof. William H. Bristol whose inventions this company has been manufacturing since it was first organized in 1889. Prof. Bristol assumed active charge of the management of the business on Friday, March 28th, and now owns the majority interest.

The business which has been carried on under the personal name of Wm. H. Bristol at New York will hereafter be combined with The Bristol Company, and by this consolidation of interests The Bristol Company will now have the most complete line of recording instruments in the world for pressure, temperature, electricity and for a great variety of other applications.

The Bristol Company was organized in 1889 under the name of "Bristol's Manufacturing Company" to manufacture Bristol's pressure

gauges and Bristol's steel belt lacing, for which Wm. H. Bristol had taken out patents. To these were added many other inventions from time to time, and in 1894 the business was incorporated under the name of "The Bristol Company."

Two years ago Wm. H. Bristol withdrew from the presidency of the company, and since that time has developed many new inventions, including the Wm. H. Bristol electric pyrometers and patented smoke chart recorders. The new pyrometers have come into wide use, there being, for instance, fifty of these pyrometers in service in one of the large steel plants.

Mr. Bristol has taken out a large number of patents during the last three years on new instruments. One of these which will be soon put on the market is the long distance electric thermometer, designed especially for indicating and recording refrigeration, atmospheric and drying temperatures. This instrument will fill a long-felt want for use where it is desired to quickly indicate at some central station by means of switches the temperatures at several distant points.

The new lines of Wm. H. Bristol instruments supplement those of The Bristol Company, supplying a variety for applications for which the old instruments could not be recommended. For example, the standard Bristol's recording thermometers cannot be successfully used for temperatures above  $600^{\circ}$  F., while the Wm. H. Bristol pyrometers are being applied to great advantage for the higher ranges of temperature, especially for ranges from  $600^{\circ}$  to  $2600^{\circ}$  F.

The new lines of Wm. H. Bristol pyrometers are fitted with special movements made by The Weston Electrical Instrument Company, and are designed for extremely accurate measurements. The combined line of recording instruments to be hereafter manufactured by The Bristol Company will make it possible for the company to co-operate better than ever before with its customers in giving them perfectly satisfactory service.

### A New Vertical Pump

For many years there has been a growing demand for an inexpensive vertical steam pump of small and moderate size adaptable to boiler feeding and general service, and where the modern high working pressures necessitate substantial construction. The Blake & Knowles Steam Pump Works of New York City have just perfected a new design for a vertical duplex pump which meets these conditions and which is nicely shown by the accompanying illustration. It is especially adapted for services where compactness and strength are of prime

importance; *i. e.*, for marine use and also for power-houses and establishments where the economy of floor space is an important consideration. The pump cylinders are of the piston

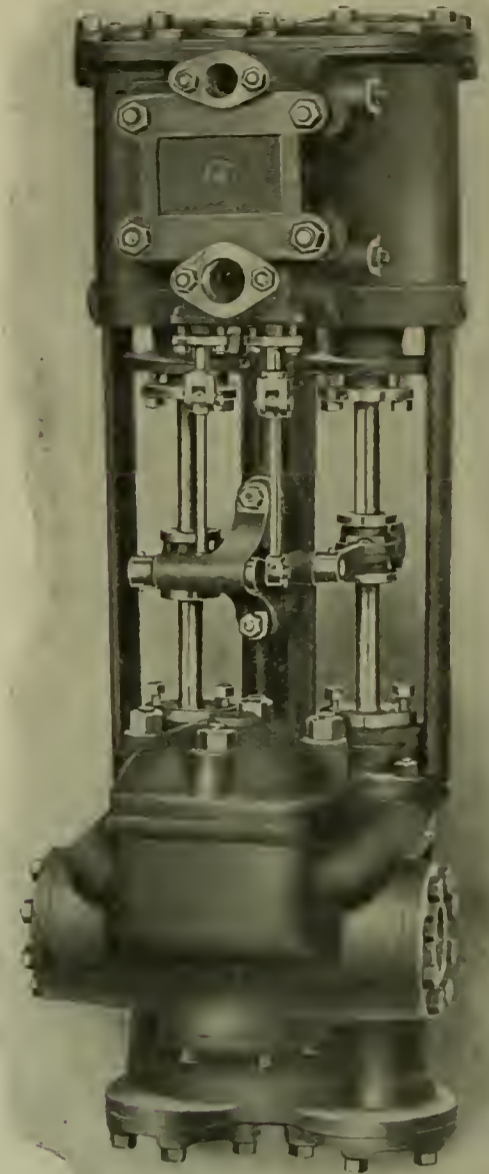

A NEW VERTICAL PUMP

pattern and fitted with substantial brass linings. The pump pistons are very deep and packed with fibrous packing suited for hot or cold water. The piston rods are of Tobin bronze. The steam cylinders are of the regular duplex pattern and of similar design to that which has for many years been successfully used with the well-known horizontal Blake-Knowles special duplex pumps. The cast iron cradle or center piece which ties the steam and water ends is extremely rigid, an improvement on the ordinary tie bar construction, as it prevents any possibility of the cylinders getting out of alignment. The cylinders are fitted with brackets for bolting to a bulkhead or wall, although if preferred a special base is fitted for placing the pump directly on the engine room floor. The pumps are suited for a working water pressure of 200 lb. per sq. in. A new illustrated publication, B-K 811, issued by the manufacturers, contains complete information with table of sizes and dimensions of this type of pump.

**Steam Turbine Sales**

We publish herewith tables giving a summary of steam turbine sales of the Curtis vertical turbine and the Westinghouse horizontal turbine. The figures are up to Dec. 31, 1907, from the beginning of the steam turbine era.

A number of interesting facts are revealed in the statement of Curtis turbine sales.

Curtis turbine generators for the past fiscal year of the General Electric Company, 286,320 kw. capacity, or more than 25 per cent. of the total sales since the Curtis turbine was introduced.

Another fact of considerable interest is the large number of plants for which the Curtis turbine has been selected as prime mover. The large

**New Allis - Chalmers Alternator for Nevada - California Power Company, Goldfield, Nevada**

The Nevada - California Power Company, formerly the Nevada Power, Mining and Milling Company, Goldfield, Nev., is preparing to install a fourth Allis-Chalmers alternating-current generator, of the water-wheel type, having 1500 kw. rated capacity, to augment the enlarged power service now contracted for in the vicinity, pending the completion of their new hydro-electric stations on Bishop Creek, Inyo County, California.

The unit is a 3-phase, 60-cycle, 2200-volt machine to run at 400 rev. per min. and is arranged for direct connection to a water-wheel operating under an 850 ft. head, alongside of three similar units already installed and similarly driven, the last of which was placed in service in 1905.

These generators are of the standard Allis-Chalmers water-wheel type, with two bearings and extended shaft. Current is transmitted 113 miles at 60,000 volts to Tonopah and Goldfield, Nev., with branches from this line to other points, and supplies power to a number of the mines in that district whose equipment is electrically operated. The following are a few of the properties in Tonopah and Goldfield which have installed Allis-Chalmers induction motors ranging in size from 5 to 100 h.p., and are supplied from the Nevada-California Power Company's mains: Goldfield Consolidated Mines Co., Goldfield Milling & Mfg. Co., Nevada Goldfield & Reduction Co. and Montana Tonopah Mining Co. The latter company has installed fifteen motors aggregating 600 h.p. With the completion of its two stations, the Nevada-California Power Company will possess hydro-electric power facilities unequalled in this section, as there are two plants already in operation, and the combined capacity will be 14,000 h.p. Much additional power can also be developed, as the company controls 3,200 ft. of fall on Bishop Creek, and large storage reservoirs can be built on the headwaters of the stream at no great cost.

**Incandescent Lamps for Singer Building, New York**

It has been announced that the new Singer Building, New York, will require some 25,000 lamps to fill the sockets, and the first shipment of 10,000 lamps has been made. Two hundred and thirty-volt Columbia lamps will be used, the contract having been secured by the Central Electric Company of Chicago, general Western sales agents for the Okonite Company.

CURTIS TURBINE SALES

ORDERS to Dec. 31, 1907	NUMBER OF PLANTS		Total number of plants	Average kw. cap. of plants	Total kw. capacity
	Capacity 1000 kw. and less	Capacity above 1000 kw.			
Central Station and Railway Traction.....	71	190	261	3,778	986,020
Industrial Plants and Miscellaneous.....	243	45	288	305	87,675
Totals.....	314	235	549	1,956	1,073,695

	Number of machines	Average kw. capacity per machine	Total kw. capacity
Installations to Dec. 31, 1907.....	943	857	807,610
Orders on hand Dec. 31, 1907.....	153	1,739	266,085
Total Sales to Dec. 31, 1907.....	1,096	980	1,073,695
Orders for fiscal year ending Feb. 1, 1908.....	325	890	286,320

WESTINGHOUSE STEAM TURBINE SALES

CLASSIFICATION	PLANT CAPACITY		Total number of plants	Av. ca- pacity of turbines kw.	Total capacity kw.
	up to 1,000 kw.	above 1,000 kw.			
<i>Electric Traction</i>					
Electric Railways.....	18,900	263,700	69	1,975	282,600
(R.R. Electrification).....		46,900	4	3,350	46,900
Total.....	18,900	310,600	73		329,500
<i>Electric Lighting</i>					
Central Stations.....	23,550	156,550	73	1,440	180,100
Isolated Plants.....	3,200		7	400	3,200
Municipal.....	4,000	4,700	11	570	8,700
Total.....	31,700	161,250	91		192,000
<i>Steam Railroads</i>					
R. R. Electrification.....		46,900	4	3,350	46,900
(R. R. Car Shops).....	9,200	6,500	17	490	15,700
Total.....	9,200	53,400	21		62,600
<i>Industrial</i>					
Textile Mills.....	8,200	5,500	22	595-20	13,700
R.R. Car Shops.....	9,200	6,500	17	490-30	15,700
Cement Mills.....	700	6,400	5	1,012-7	7,100
Iron and Steel Works.....	1,000	4,000	3	500-10	5,000
Pulp and Paper Mills.....	800	6,200	5	778-10	7,000
Rubber Works.....	900	3,450	4	621-7	4,350
Powder Works.....	1,200		2	400-3	1,200
Machinery Manufacturers.....	5,400	9,600	12	576-30	15,000
General Manufacturers.....	5,750	1,500	11	453-15	7,250
Total.....	33,150	43,150	81	132	76,300
Mining and Irrigation.....	8,000	13,950	19	686	21,950
U. S. Government.....	1,750	10,500	4	1,225	12,250
Miscellaneous.....	6,700	2,000	14	483	8,700
Grand Total.....	99,250	541,450	282		640,700

Industries in parentheses, but allowed for in grand total.  
NOTE.—Business uncompleted December 31, 1907: 60 turbines of 153,550 kw., total, leaving shipped or in operation 433 machines, or 487,150 kw., averaging 1,122 kw.

The most noticeable single item is the total capacity sold to Dec. 31, 1907—1,073,695 kw., or about 1,556,000 brake h.p. This is the strongest indication of the advance of the steam turbine generating unit that has ever been published. That this advance is accelerating rapidly is shown by the amount of the sales of

range of sizes in which this turbine is sold is probably responsible for the great variation in average sizes of plants in which it is used. The large central stations and electric traction enterprises with an average size of 3778 kw. plant capacity strikingly differ from the industrial plant of 305 kw. average capacity.

## Trade News Items

The Northern Engineering Works, of Detroit, have furnished the Mammoth Copper Mining Co., of Kennett, Cal., with a 15 ton, 48 foot span Northern traveling crane.

The Northern Engineering Works, Detroit, Mich., report recently shipping to the Nederlandsche Gist en Spiritusfabrik, Delft, Holland, an overhead track system, consisting of approximately 500 ft. of overhead track with hangers, switches, etc., and an electric one-ton trolley hoist, two-motor alternating-current design.

The Chas. J. Bogue Electric Co., will remove on May 1st from 213 Centre Street to 513-515 West 29th St., New York.

The telegraph, telephone and electric-light companies reported the purchase of 3,493,025 round poles exceeding 20 ft. in length in 1906. Over three-fifths of these poles consisted of cedar and more than 28 per cent. of chestnut. Relatively small amounts of pine, cypress, redwood and other poles were also purchased. In addition to the poles required by these commercial companies, a large number of smaller poles were used for local telephone lines and similar purposes.

The Electric Cable Company, of 17 Battery Place, New York, whose plant at Bridgeport, Conn., was partially destroyed by fire, announce that they have made arrangements which will permit of filling all orders. Pending adjustment of insurance details, the Company will make no announcement of its plans for re-building.

The semi-annual meeting of The American Society of Mechanical Engineers will be held in Detroit, Mich., June 23-26. Among the papers to be presented at this session are A Method of Cleaning Gas Conduits, by W. D. Mount; A Method of Checking Conical Pistons for Stress, by Prof. George H. Shepard; Clutches, with special reference to automobile clutches, by H. Souther; Horse-power, Friction Losses and Efficiencies of Gas and Oil Engines, by Prof. L. S. Marks; Some Pitot Tube Studies, by Prof. W. D. Gregory; The Thermal Properties of Superheated Steam, by Prof. R. C. H. Heck; A Journal Friction Measuring Machine, by Henry Hess; A By-Product Coke Oven, by W. H. Blauvelt; Tests of Some High Speed Steam Engines, by F. W. Dean.

The executive offices of the Westinghouse Electric & Manufacturing

Company, now at 111 Broadway, New York, N. Y., and the New York sales offices and export offices, of that Company, now at 11 Pine Street, have been removed to the new City Investing Building, 165 Broadway, New York.

The general offices of the General Electric Co., of the American Locomotive Co., and the New York sales office of the Crocker Wheeler Co., have been removed to the Hudson Terminal Building, 30 Church Street, New York.

The Wheeler Condenser & Engineering Co., Carteret, N. J., has made arrangements with Charles S. Lewis & Co., Granite Building, Fourth and Market Streets, St. Louis, Mo., to handle "Wheeler" apparatus in the State of Missouri.

The Westinghouse Machine Company, builders of the Roney mechanical stoker, reports for the first two months of this year a good demand for stoker equipment. The Merchant's Ice & Cold Storage Company, of Cincinnati, are installing three equipments; the Montgomery Ice & Cold Storage Company, Jenkintown, Pa., two equipments; and the Holt Ice & Cold Storage Company, Indianapolis, Ind., the same number. Another municipal lighting station at Troy, O., operated by the Board of Public Service, has adopted Roney stokers, and the Pennsylvania Light, Heat & Power Company, of Allegheny, Pa., operating a large central station at that place, increases its present equipment with two stokers of large capacity. The Mutual Union Brewing Company, Alliquippa, Pa., is installing three equipments, and the Alpha Portland Cement Company, operating a number of plants in the country, one of the largest size.

The Duquesne Steel Foundry, which operates a large plant in the Pittsburg district, has decided to adopt the gas-power system to operate the works formerly driven by steam. The initial equipment will consist of a 400 h.p. (max.) Westinghouse gas engine of the three-cylinder vertical enclosed type, direct connected to a 240 kw. generator which will serve the various motor drives around the plant.

In the United States Circuit Court of Appeals for the Third Circuit, the Westinghouse patent No. 582481, issued to Nolan, assignor, for fastening the laminæ of core plates, was upheld in a suit brought by the appellee against the Prudential Life Insurance Co.

## Catalogue Notes

Graded shunt resistance multigap lightning arresters for 1908 are described in a new bulletin issued by the General Electric Company, Schenectady, N. Y. The bulletin also contains detailed descriptions of low voltage arresters, static dischargers, constant-current horn arresters, disconnecting switches, choke coils and the well-known Type M, Form D-2 direct-current arrester for voltages up to 6000. Tables of general data regarding the apparatus, connection and dimension diagrams, etc., are included. The multigap arresters for high voltages consist essentially of a series of knurled cylinders placed closely together, the discharge taking place across the path of gaps thereby produced and being extinguished before the dynamic current can follow it for more than half a cycle by reason of the peculiar composition of the metal making up the cylinders.

The arcs are shunted by low, medium and high resistances which have the effect of making the arresters sensitive to a very wide range of frequencies and are claimed to discharge with safety under practically all conditions.

The multiple connection of the arresters allows them to relieve strains between line and line as well as between line and ground. An important feature of their design is the absence of series resistance which gives a free discharge at high frequencies as well as a free discharge of large quantities of lightning. The bulletin discusses briefly the theory upon which the arresters operate and their details of construction. It is bound in an artistic cover.

## EDISON "GEM" HIGH EFFICIENCY INCANDESCENT UNITS.

In Bulletin No. 4561, the General Electric Company, Schenectady, N. Y., has issued an interesting 16-page pamphlet on illumination and the best solutions of many of the problems involved. Illumination tables giving the foot-candle values on different horizontal planes when the lamp is used with various types of Holophanes are also given. The "Gem" unit is easily renewed, fits the standard socket and burns on any standard circuit. It gives a perfect distribution of light with a downward efficiency of from  $1\frac{3}{4}$  to nearly one watt per candle, and the quality of light is brilliant, soft and uniform, making it especially useful for all interior lighting. The "Gem" units are inexpensive, giving low investment charge and cheap renewals, and no repair account is necessary with their use.



# THE ELECTRICAL AGE

Volume XXXIX. Number 5.  
\$1.00 a year; 15 cents a copy

New York, June, 1908

The Electrical Age Co.  
New York and London

ESTABLISHED 1883

Published monthly by The Electrical Age Co., 45 E. 42d Street, New York.

J. H. SMITH, Pres. C. A. HOPE, Sec. and Treas.

JOHN HAYS SMITH, Editor.

Telephone No. 6498 38th. Private branch exchange connecting all departments.

Cable Address—Revolvable, New York.

## SUBSCRIPTION RATES

United States and Mexico, \$1.00; Canada, \$1.50. To Other Countries, \$2.50

## NOTICE TO ADVERTISERS

Insertion of new advertisements or changes of copy cannot be guaranteed for the following issue if received later than the 15th of each month.

## LONDON OFFICES

Business and Editorial Departments, 33 Bedford Street  
Strand, W. C.

Londoo Telephone, Post Office, 3807 Central. Private branch exchange. London Cable  
Address—Revolvable, Londoo.

All remittances to London Office should be crossed London and County Banking Company.

## BRANCH OFFICES AND AGENCIES

Subscriptions may be sent to the following branch offices or agencies, where they will receive the same careful attention as at the home office in New York:

124, Queen St., Melbourne  
359, George St., Sydney  
61, Main St., Yokohama  
23, Esplanada Rd., Bombay

33, Loop St., Cape Town  
Unter den Linden, 5, Berlin  
Nevsky Prospect, St. Petersburg  
31, bis rue de Fauburg Montmartre, Paris

General Agents for United States and Canada: The American News Company

## General Electric Company's Report

The sixteenth annual report of the General Electric Co., dated Jan. 31, 1908, is remarkable as an exposition of a continued far-sighted policy of ultra conservatism in internal affairs, together with an equally notable policy of liberalism during troublous times in dealing with the vast aggregation of industries represented by 21,000 regular customers. This was a policy intended to minimize the effect of hard times, and not to "kill the goose that lays the golden eggs."

The evidence of this is found in the item of \$31,957,999.73, shown as due from customers on Jan. 31, 1908.

Of this sum \$9,396,242.59 is in the form of notes, and \$22,561,757.14 in open accounts. This sum remains due after making cash collections of about \$66,000,000, although the sum remaining due is only about \$3,500,000 more than was due the year before at the same date; it really represents a more important item.

It is known that the business of the early part of the year was at a rate of \$85,000,000 a year. When the slump came, sales fell off to such an extent that the total of orders received for the year was but \$59,301,040, and the total sales billed was \$70,977,168. This, however, was an increase of 18.2% over the previous year.

"Of some 21,000 regular customers," the report says, "an increase of 1300, there were debit balances against 10,000 at the close of the year."

It is not difficult to read between the lines and to discover a broad-minded policy carried out which kept the wheels of other industries going by not withholding the needed supplies and equipment, although deliveries involved the taking of extraordinary risks for collections. These risks have been provided for by writing down the asset value of accounts receivable by the sum of \$2,100,272.89.

The conservative internal policy referred to is evidenced by those portions of the report which show the writing off of millions in items which most companies carry along year after year as book assets. The first of these items is a sum of \$872,345.67 expended during the year in acquiring patents, licenses under patents and in patent litigations. This is in accordance with a policy which leaves all the company's patents, franchises and good-will standing on the books at a valuation of only \$1.00.

The same policy has been followed in dealing with investments in factory properties and materials on hand.

The sum of \$3,745,989.06 was written off during the year from the cost of factory properties, and the book value of the stock inventories advanced by \$2,000,000, bringing the reported value of all material in hand below the market values on Jan. 31, 1908, regardless of cost.

The total sums written off the cost of factory properties during the last 15 years has been \$21,951,013.93, leaving these properties valued at only \$12,900,000. This represents a cost chargeable to manufacturing of only \$2.00 a square foot of floor space.

That this plays an important part in enabling the company to compete for the world's business is evident when it is considered that the average cost in the large electrical factories of the world is between \$4 and \$6 per square foot of floor space.

Almost the entire cost of the Pittsfield plant of the Stanley Works, which was forced upon the company in 1903, has finally been liquidated.

Notwithstanding the large sums written off, the declared profits of the company for the year were \$6,586,653.37. From this, dividends amounting to \$5,183,614 were paid during the year, and an amount of \$1,403,039.37 was carried to the surplus account, making a total surplus of \$16,513,836.14. Another item which at-

tracts attention is the sum of \$12,250,720.92 cash in hand on Jan. 31, 1908.

This large sum represents the cash which was provided in 1907 by the issue of \$12,872,750.00, in 5 per cent. bonds, to provide ample working capital for the great volume of business then in sight. As business fell off in the latter part of last year, this sum returned to the treasury and is now in hand, ready to be employed whenever a revival of business may require it.

Comment has been made upon the apparent falling off of the percentage of manufacturing profits for the year.

The profits are said to have been actually reduced about 1 per cent. by the high price of materials and other temporary causes, but the other change is entirely accounted for by the conservative course of the management in putting all of the assets on a basis which cannot apparently be adversely affected, even if the revival of business is delayed even beyond the most pessimistic expectations.

Reference is made in the report to the purchase of 700 acres of land near Erie, Pa., at a cost of \$232,301.53, to provide for future development at some point nearer the central West. "In view of the existing depression," the report says, "the erection of buildings thereon is deferred for the present."

## Downward vs. Horizontal Illumination

In the April issue of THE ELECTRICAL AGE there is an article by Mr. T. H. Amrine, in which the question of the relative advantages of distribution, as between the commercial forms of incandescent lamps, is discussed. The writer falls into an error which is undoubtedly common enough among laymen, but one which it is important that those professionally interested in illumination, at least, should avoid.

This error consists in considering the area of the ordinary distribution curve as significant of quantities of light. This error is as natural as it is wide of the truth. So natural is it to compare the areas of distribution curves that it often requires careful and elaborate explanation to convince the untechnical observer that the area has no significance whatever and that only the length of the radial lines must be taken into consideration.

One of the stock arguments against the type of incandescent lamp, of which there are several commercial varieties, which aims to give a greater amount of light in the vertical direction than the ordinary type, is the light lost in the base. Mr. Amrine attempts to show this by shading portions of polar diagrams of the so-called "downward light" type and the familiar oval-anchored filament type. A little consideration of the mathematical problem involved will show that this well-worn argument has almost nothing to rest upon, and should have been worn out and discarded long ago. The fallacy of the argument may be summed up in two points: In the first place, the quantity of light intercepted by the base of the lamp is so small as to be practically negligible; second, a considerable portion of this light is reflected by the glass and cement with which the base is attached.

A glance at the familiar Rousseau diagram will show how extremely small in quantity are the amounts of light included within given angles near the poles, as compared with similar angles near the equator. Thus, the amount of light falling within the 15 degrees from the vertical is less than 2 per cent. of the total flux, assuming the intensity to be equal in all directions; and this amount undoubtedly exceeds the total amount of light actually intercepted by the base of the lamp. The absorption-in-the-base argument may, therefore, be dropped as wholly academic and impractical.

As to the relative merits of the different types of lamps when used with reflectors, that is quite a different matter, and, as in the case of the lamps used bare, will depend largely upon the particular type of distribution wanted. If a wide distribution is desired, unquestionably the lamp having a naturally wide distribution is preferable, since it is difficult to deflect rays that are included, say, within the vertical and 45 degrees, into a direction nearer the horizontal. On the other hand, if vertical concentration is desired, then the lamp having naturally a greater intensity in the vertical is easier to handle.

There are, however, a considerable

number of cases in which accessories by way of shades and reflectors are undesirable, as, for example, where the risk of mechanical breakage is great, or the presence of smoke or dust renders them unfit for their purpose. In such cases lamps having a high vertical intensity will have the advantage for most purposes where incandescent lamps would naturally be used.

The advocate of the standard type, that is, the type giving a horizontal intensity practically twice the vertical, will, of course, call attention to the fact that the vertical, or so-called "downward type," gives equally high intensity upward, barring the absorption by the base. While this is true, the argument applies just as well to any other type of lamp. In other words, all types of lamps give practically the same quantity of light above as below the horizontal plane passing through the filament, that is, divide their light equally between the upper and lower hemispheres. Since, in the case where lamps are used bare, the light in the upper hemisphere may generally be considered useless, the argument, as between the two, narrows itself down to the distribution in the lower hemisphere.

In choosing between the several types of incandescent lamps, then, the points to be considered are:

First—Is the use of a reflector possible or advisable?

Second—If a reflector is to be used, is a wide or concentrated distribution desired?

Third—If reflectors are not to be used, is a general distribution, or special lighting required?

In any case, let it be borne in mind—First, that the particular form in which the filament is looped or placed in the lamp has absolutely nothing to do with the efficiency of the lamp. You cannot get something for nothing by simply giving a peculiar twist to the filament.

Second, a lamp that is giving greater intensity in some particular direction than some other form of lamp must, of necessity, be giving less intensity in some other direction. It is merely a matter of deciding in which direction it is most desirable to have the intensity.

Third, the polar, or distribution curve, as commonly given, indicates how the light is distributed on the average in a vertical plane, and is to be read as a curve only, the area included having no significance whatever.

If these facts be thoroughly understood and remembered, the opportunities for misunderstanding on the part of the user, and misrepresentations on the part of the seller—which latter

are happily of comparatively rare occurrence at the present time, thanks to the establishment of illuminating engineering—will be reduced to a minimum.

### The Boron Jewel

It is understood that the research laboratory of the General Electric Company, which is commonly reported as spending \$200,000 annually in its quest for new things of commercial profit, has succeeded in devising a new method of isolating the element boron in a crystalline form of absolute purity. The value of boron to the electrical industry lies in the fact that it is a non-conducting substance of great hardness, which can be cut like the diamond or sapphire into jewels for use in electric meters and other instruments of precision.

Boron is much harder than the sapphire in any of its forms, all of which it scratches readily, being very close to the diamond in hardness. This fact has been known to chemists and mineralogists ever since Wöhler and Deville, in 1856, at Goettingen, succeeded in converting amorphous brown boron into the crystalline form, though they were unable, owing to the crudity of the chemical process employed by them, to get crystal boron of perfect purity. The boron made by the laboratory at Schenectady is said to be the first which is chemically pure. It is understood that the process of manufacture is by the electric furnace, producing a cheap and easily manipulated product, which can be molded into shape while in a liquid condition. Thus it seems possible to produce a meter jewel much superior to the sapphire, of a close hardness to the diamond, and at a very low cost.

The significance of this industrial discovery will be understood when it is considered that there were about 300,000 electric meters manufactured in this country last year. More than half of them carried two jewels per instrument, so that the total number of jewels cut from sapphire for this purpose was about 475,000 in the year. A jewel costs the manufacturer from 30 to 40 cents apiece, so that we have here an expenditure of more than \$150,000 annually for jewels. This was, however, the year of largest output.

It may be useful to sketch briefly the chemical process hitherto employed in the preparation of crystal boron, as it is suggestive of the means to be employed to reduce it in the electric furnace.

Boron occurs most commonly in nature in the well-known form of borax ( $\text{Ma}_2\text{B}_4\text{O}_7 + 10\text{H}_2\text{O}$ ), from

which boron trioxide is readily obtained.

Ten parts of boron trioxide and six parts of metallic sodium are mixed in a crucible already heated to redness, and covered with a layer of powdered sodium chloride well dried. As soon as violent reaction subsides, the mass is stirred with an iron rod until the sodium is oxidized, and then carefully poured into water, while the boron remains behind as a brown amorphous powder.

This is then collected on a filter, and it must be carefully dried, as it is easily oxidized and may take fire. Amorphous boron does not undergo change in air or oxygen, nor melt at an ordinary white heat, though it is easily fusible in an electric furnace.

"If amorphous boron be pressed down tightly in a crucible, a hole bored in the center of the pressed mass and a rod of aluminum dropped into the hole and the crucible heated to whiteness, the boron dissolves in the molten aluminum and separates out in the crystalline form when the metal cools. The aluminum is then dissolved in caustic soda, and thus the insoluble boron is left in large transparent yellow or brownish crystals.

"The same modification may be obtained by melting together boron trioxide and aluminum, forming smaller crystals, often joined together in long prismatic needles.

"In order to prevent the action of air upon the fused mass, the crucible is placed in a larger one, filling in the space with powdered charcoal.

"In this process boron takes up 2 to 4 per cent. of carbon, probably in the form of diamond carbon. There is also a certain percentage of iron and silicon from the crucible. These impurities can be removed by treatment with HCl, and afterward with a mixture of HNO<sub>3</sub> and HF.

"These crystals of adamantine boron, according to Hampe, contain aluminum as well as carbon, and possess a constant composition B<sub>48</sub>C<sub>2</sub>Al<sub>3</sub>—Roscoe & Schorlemmer"

#### Sapphire and Diamond Jewels

For twenty years the electrical industry has been endeavoring to discover some cheap form of jewel for supporting the moving part of meters and instruments of precision. Where the movement is only occasional, quartz or agate suffices very well, but where the movement is continual, as in electric meters, even the sapphire (hardness 9) wears away and the supporting jewel soon loses its proper curvature. For this reason the dia-

mond, in spite of its cost, has been much employed in the commercial electric meter.

Sapphire jewels are chiefly imported from Ceylon, and until lately have been cut on the continent at Geneva and at Amsterdam, costing about 30 cents apiece in the finished form, though the price is subject to wide variations, owing to the uncertainties of the supply. The discovery of boron for jewel work will free the manufacturer from the uneven jewel market and justify its adoption for this reason alone.

The two most common forms of meter on the market are the Westinghouse induction meter and the Thomson-Houston recording meter. The Westinghouse meter has a very light moving part and the Thomson-Houston meter has a relatively heavy moving part, which is supported upon a jewel which in turn rests upon a spring. By long and varied experimentation, the General Electric Company has determined that the life of the jewel in this form of meter depends upon the relation between the strength of the spring and the weight of the moving part, manufacturing several types of springs.

The necessity for this variation in the spring part is due to the comparative softness of the sapphire jewel, which wears out quite rapidly in this form of meter—the average life of its sapphire jewel is about one year, when the jewel must be replaced. To maintain absolute accuracy of registration it is necessary also to recalibrate this form of meter about once in every three months, which is a serious question for a central-station. It is the general custom in progressive operating companies to go over the meters in service once a year. So far as we are aware, no central-station inspects and tests its meters as frequently as this interval would require.

Much care must be exercised in installing this form of meter in order to protect the jewel from damage to its surface, which occurs whenever the meter is located so that the moving part is subjected to jarring. For this reason users are cautioned not to place a meter upon a wooden partition, or other unstable structure; or upon a wall, which is liable to form a sounding-board, and thus magnify by rhythmical acceleration the ordinary oscillation of the moving part, which is frequently sufficient to cause the meter to give out a slight hum in operation. In this form of meter the life of the sapphire jewel probably does not extend beyond a million revolutions of the moving part.

In the form of jewel support manufactured by the Westinghouse Co. there are two sapphire jewels separated by a hardened steel ball of minute size. The life of this jewel is found to be from three to ten years, and the moving part will run about 5,000,000 rev. before either of the jewels must be replaced. The greater life of the sapphire jewel in this form of meter is due, first, to the extremely light moving part and to the clever form of bearing just described. In the Westinghouse laboratory one of these meters, which has been running continuously for three years, has registered 10,000,000 rev. without appreciable error, and after 25,000,000 rev. was found to be only 4 per cent. out on a 2 per cent. load. This remarkable performance, while in a measure due to the type of construction, must, since it exceeds the average performance, be attributed to exceptional hardness of the sapphire jewels.

It is well known that the hardness of the commercial form of sapphire bearing varies a good deal, and while formerly the Ceylon sapphire was exclusively used in meter construction, a variety of sapphire found in Montana has lately come into extensive use. Its color is milky white, as distinguished from the clear sapphire of Ceylon.

For some years back diamond jewels have been extensively used in the heavier types of meters, particularly for switchboard work. The General Electric Co. and the Edison Companies have experimented long in an effort to obtain a suitable diamond jewel for the commercial electric meter, but thus far have permitted the little information to become public.

The diamond jewel is flat because it is well-nigh impossible to concave and polish the stone in a satisfactory manner. It, therefore, is necessary to use a ring-stone of sapphire in order to hold the meter staff on the center of the diamond face. Since this form of jewel is practically indestructible, its cost, which is about two dollars per jewel, does not deter its use in meters with heavy moving elements, or where there is unavoidable vibration of magnitude. It is, indeed, common practice to provide meters of considerable capacity with diamond jewels, since their use insures accuracy at light load. Diamond jewel meters frequently show an erratic and variable speed at constant current, due to the fact that the meter staff frequently gets into contact with the ring-stone, thus increasing the meter friction.

# Meter Department of the Central Station

JOSEPH B. BAKER

THE EVOLUTION OF THE METER DEPARTMENT.

THE introduction of motor meters by central-station companies to replace the old Edison chemical meter\* tended at first toward considerable loss of revenue from friction in the meters, due to the fact that after a short period of installation the meters ran slow, especially on light loads. The large percentage of error on light loads, and the imperfect understanding at the time of the causes and remedies of such inaccuracy, doubtless delayed the introduction of metered service in place of the old flat-rate or contract system which was in vogue in the early days of electric lighting. Even after the meter situation began to be improved—on the one hand by improvements effected by meter manufacturers, and on the other hand, by better care of the meters by the operating companies—the fact that the meters, once installed, must be *maintained* in accurate running condition was slow to be recognized.

In a catalog of the old Stanley Instrument Company it is stated that "more than 60 per cent. of the current consumed in electric lighting in the United States is passed through the meters at a load of less than one-tenth of the capacity of the meter." A meter's failure to register on a load of one or two amperes may mean a loss of 50 per cent. in the revenue from residence customers. The same conditions are, however, found in churches, schools and other public buildings (banks, libraries, theaters, office buildings, etc.), where night lights, or watchmen's lights, are employed. Many central-station companies have recognized and endeavored to offset this state of affairs by establishing a "minimum charge" on consumers' bills, sometimes termed "meter rent."

The majority of the early electric light companies purchased meters in

a desultory way—the "Meter Department," in the rare instances in which that term was used, having an irresponsible, or, at any rate, an indefinite or experimental status—and installed them in an equally desultory way, with a childlike reliance upon the claims of accuracy made by the meter manufacturer whose product happened to be preferred. The matter generally ended there, so far as any consistent or sustained system of meter maintenance was concerned. Even after the use of motor meters at consumers' installations had entirely replaced both the old flat-rate system of charging—the charge being usually made on a "per 16-c-p. lamp per month" basis—and the employment of the Edison chemical meter, the central-station companies were remarkably slow in realizing the importance of efficient organization in connection with the device upon which their entire revenue depended. Up to a recent date many of the best managed companies, with elaborate and costly layouts for securing maximum economy in the generation and distribution of electricity, have been slow to sanction expenditures to secure efficiency at the other end of the proposition—the actual metering of the product as delivered to the consumers. Oftentimes the utmost care has been exercised in preventing waste at the coal pile and in securing efficient boilers and engines, and money has been spent cheerfully for the installation of larger and more efficient generators and the laying of heavier conductors, while the meters have been allowed to take care of themselves.

Though a meter that "runs fast" may occasionally be found, due to extraordinary conditions or accidentally defective adjustment, the natural tendency of a meter, as of any machine, is to "run slow" in service. Adequate calibration, therefore, much more than pays for itself in preventing losses through underregistration.

The advisability of maintaining the accuracy of a central-station company's meters by adequate rating and calibration is demonstrated by the fact that a 1 per cent. increase in revenue, secured by such maintenance is equivalent to a saving of several per cent. in the coal bill. Moreover, only by maintaining the accuracy of its meters can a company be in a position

to adjust its charge equitably for all of its customers. Occasional customers whose meters are found to be registering far too low may be disgruntled on finding that their meters are running faster following the visit of the inspector, and may order the service discontinued. Such customers are, however, undesirable anyway, since acceding to their demands results either in loss of the power delivered to them or in injustice to other consumers by the effect on the rates of such virtual discrimination.

Modern methods demand high efficiency in all departments, however, and with growing realization, by central-station companies, of the importance of the meter proposition, it has become well recognized that in addition to selecting correctly designed and well-constructed meters and installing them with care, the meters must be systematically maintained at their initial accuracy.

In this connection Mr. W. J. Mowbray, in a paper entitled "Maintenance of Meters," presented at the A. I. E. E. meeting of April 28, 1905, says:

"To the company supplying electric energy which is measured by meters and charged for accordingly, the maintenance of meter accuracy is of supreme importance. Losses in other apparatus become insignificant when compared with the loss of revenue from meters that are allowed to follow their natural tendency to run slow. For example, in a steam boiler a drop of 10 per cent. from normal efficiency would be detrimental to approximately the same percentage in the single item of the cost of coal, whereas in the meter system it would be 10 per cent. of the entire gross revenue to which the supplying company is legitimately entitled. Furthermore, if a metering system did actually deteriorate so as to record 10 per cent. less than the true energy, this loss would by no means remain constant; it would continue to increase.

"Periodic overhauling is the obvious and generally adopted means of maintaining meter accuracy. Overhauling—a strict examination for correction and repairs—is efficient in proportion to the cheapness and accuracy with which it is done, and to the permanence of the result."

In recognition of modern ideas,

\*The writer has heard that in the early days of the use of the Edison Chemical Meter, it was the custom in some companies to estimate the customers' bills by a mere inspection of the amount of deposition of zinc on the meter cathodes. Thus the "expert," seated at a table on which were piled the zincs just removed from a group of consumers' meters, would pick up each zinc in turn, examine it critically, and announce "No. 24, \$1.40; No. 47, \$3.00; No. 10, \$2.25"—and so on. This practice has, of course, sooner or later superseded by the system of accurately determining the increase of weight of the cathodes; a system which remained in operation, subject to various refinements and modifications, until the discontinuing of the use of the Edison meter.

the meter departments of central-station companies have been given more scope. The increased efficiency, showing as direct increase of revenue, to be attained by consistent testing of the connected meters, and the good results to be attained by handling the clerical work connected with installing, reading and testing of the meters directly by, or in close co-operation with, the meter department have been recognized, and in the larger companies have led to something like the following organization:

1. A stockroom and construction department for storing, installing and removing consumers' meters.

2. A testroom for the systematic testing and calibrating of the meters before installation, and after removal for any cause from consumers' premises; with facilities for repairing and making over meters, and a system of routine and special testing of the meters on the customers' premises.

3. A combined meter-reading and bill-computing organization, handling all routine and special meter reading and the entire clerical work connected with the actual billing of the consumers.

These different parts of the meter work are discussed in other chapters.

Although the meter departments of central-station companies do not usually embrace the management of all the above divisions of the meter work, it is recognized that there should be free and intimate co-operation among them.

The importance of such co-operation for the good of the service may be illustrated, for example, by the need of agreement between divisions 1 and 3 on the location of meters to be installed, involving consultation in some individual cases to ensure that the meter is located to the best advantage for testing and reading. Again, division 2 and 3 need to keep in touch to ensure the laying of concordant (non-clashing) meter routes for testing and reading, respectively.

In a few companies, however, the advantages gained by close co-operation and a common clerical system have led to the including of all the above divisions in the province of a single Meter Department.

METER READING.

The accurate reading of installed meters is obviously a matter of great importance. Errors in reading consumer's meters result in inaccurate bills, which are exasperating no less to the company than to the consumer, and it is always advisable to employ as meter readers only men who are thoroughly competent and trust-

worthy. With many companies it is customary to shift the men about on the different "meter routes" or sections, so that no one man reads the same route twice consecutively.

The meter readers are often instructed to make a superficial examination of the meter and its wiring, etc., and to report anything defective or irregular about the installation.

In most companies the meters are usually read once a month, except in special cases, where it is necessary to render bills weekly. In small and medium-sized systems, where a comparatively small number of meters are in use, it is customary to read all of

hands or pointers on a printed facsimile of the meter dials.

Many different styles of printed forms for recording the dial readings are employed. Fig. 1 shows a form printed on the back of a "meter card," designed for one year's readings. These cards are filed by meter routes, *i. e.*, in the order in which the meters are to be read. The cards for any meters disconnected can thus be removed, and the cards for meters added can be inserted in their proper places. One such diagram is provided for each reading of each consumer's meter, and the meter reader marks upon it the position of the pointers and turns it

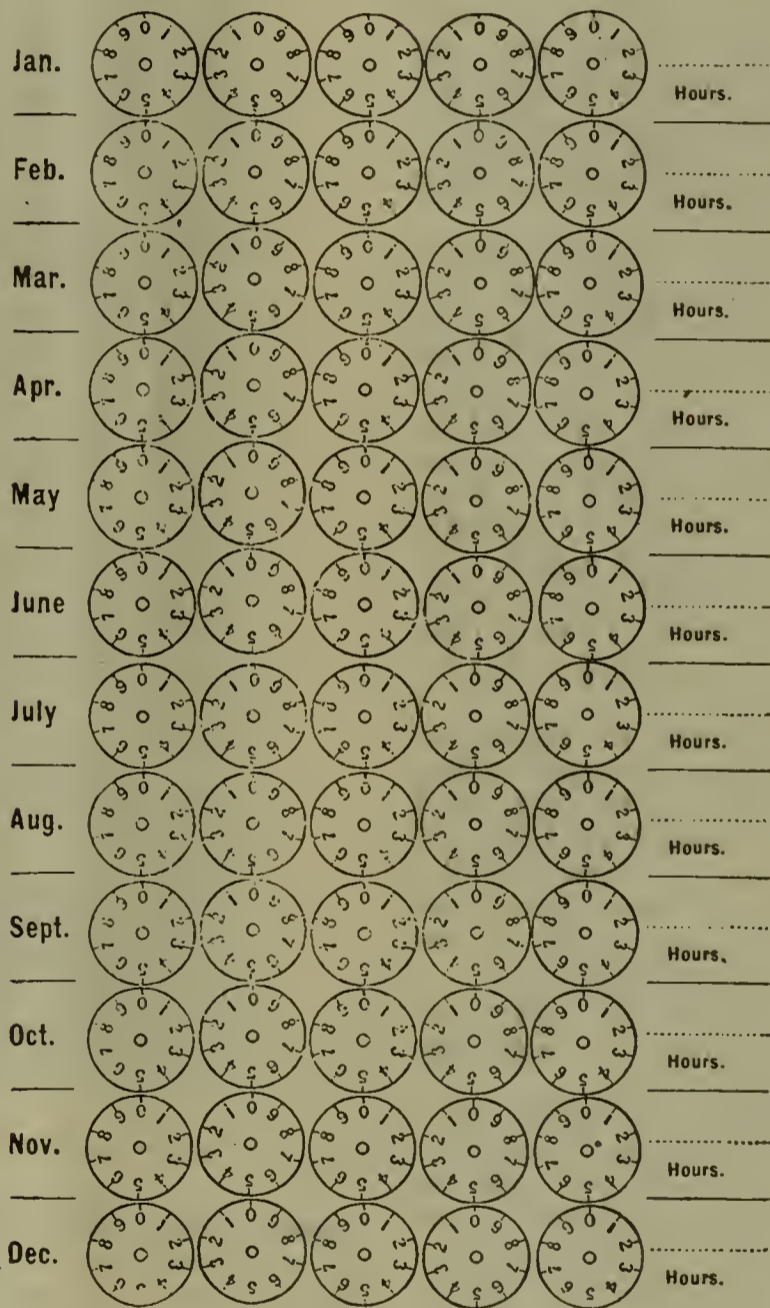

FIG. 1.—PRINTED FORM FOR TRANSCRIBING DIAL READING.

the meters during the last few days of the month and present the bills on or about the first of the following month. On large systems in which the great number of meters renders this method impracticable, it is customary to divide the city into sections and read one section every day.

*Methods of Recording the Dial Readings.* The following two general methods of recording the readings are in use:

1. By marking the positions of the

in as a permanent record, to be reduced to watt-hours by some responsible person. The chief advantage claimed for this method is that it insures closer inspection of the dials by the meter reader, as he is required to record the positions of the hands to represent as nearly as possible their true positions on the dial. The records also furnish a complete history of the successive positions of the dial hands, month by month, which, in the case of complaint resulting from

loose or misplaced dial hands, is frequently of service in adjusting the matter.

As against these claimed advantages, it is fair to assume that ability to mark a dummy card correctly for all positions of the dial hands should qualify the meter reader to record the reading directly in figures: a proposition which implies that the method is more useful for training the novice than for regular use by the expert.

2. By recording the reading directly in figures; the advantage claimed for this method being that it is somewhat more rapid and less cumbersome. It is believed that most expert meter readers employ this method.

*Directions for Reading the Dials.* Whichever of the two methods is used certain positions of the pointers are difficult of interpretation, necessitating great care in reading the register. Hence the following directions should be carefully observed:

A. Note carefully the unit in which the dials read, *i. e.*, whether in watt-hours or in kilowatt-hours. In some makes of meters (*e. g.*, General Electric Company meters) the number marked above or below each dial indicates the value of one complete revolution of the corresponding pointer, so that one division on the dial indicates one-tenth of the printed number. In other makes of meters (*e. g.*, the Westinghouse) the printed number indicates the value of one division on the dial.

B. Note directions of rotation of the pointers. Thus in General Electric meters the pointers of the first, third and fifth dials (counting from the right) rotate in the clockwise direction, whereas the pointers of the second and fourth dials rotate in the counter-clockwise direction.

C. Read the dials the reverse in order of their value, *i. e.*, beginning with the right-hand dial.

Most expert meter readers, however, read the dials in the direct order of their value, *i. e.*, in the order in which the figures are set down to express the reading in kilowatt-hours—except in the case of very difficult readings, which have to be “built up” carefully from right to left.

D. Always read the figure on each dial which the pointer has last passed over or which it just covers. But note carefully that the reading of each dial depends upon the reading of the one next to it on the right. Unless the next pointer on the right has completed a revolution, as shown by its position directly over the zero or a little way past it, the pointer which is being read has not completed the division indicated by the figure upon which it may appear to rest, and still indicates the figure last passed over.

E. See whether the register is direct reading, or whether it has a multiplying constant. Some registers are not direct reading, but require that the reading be multiplied by a constant in order to obtain the true number of watt-hours. Under no circumstances should a constant be used in recording a reading unless the dial face bears a multiplying factor; for example, the words “multiply by  $\frac{1}{2}$ ,” or “multiply by 10.”

The necessity of exercising care in reading the dials is illustrated by the

Nos. 2, 3, 9, and 10 may be taken as examples of “difficult readings.” In any meter register the pointers sometimes become slightly displaced, as shown in Nos. 3 and 4, but the actual indication may be determined by the reading of the pointer at the right of the one in question.

Additional examples of dial readings are given in the following explanatory text referring to Fig. 3, with directions for billing reproduced from a publication of the Duncan Electric Mfg. Company. The registers

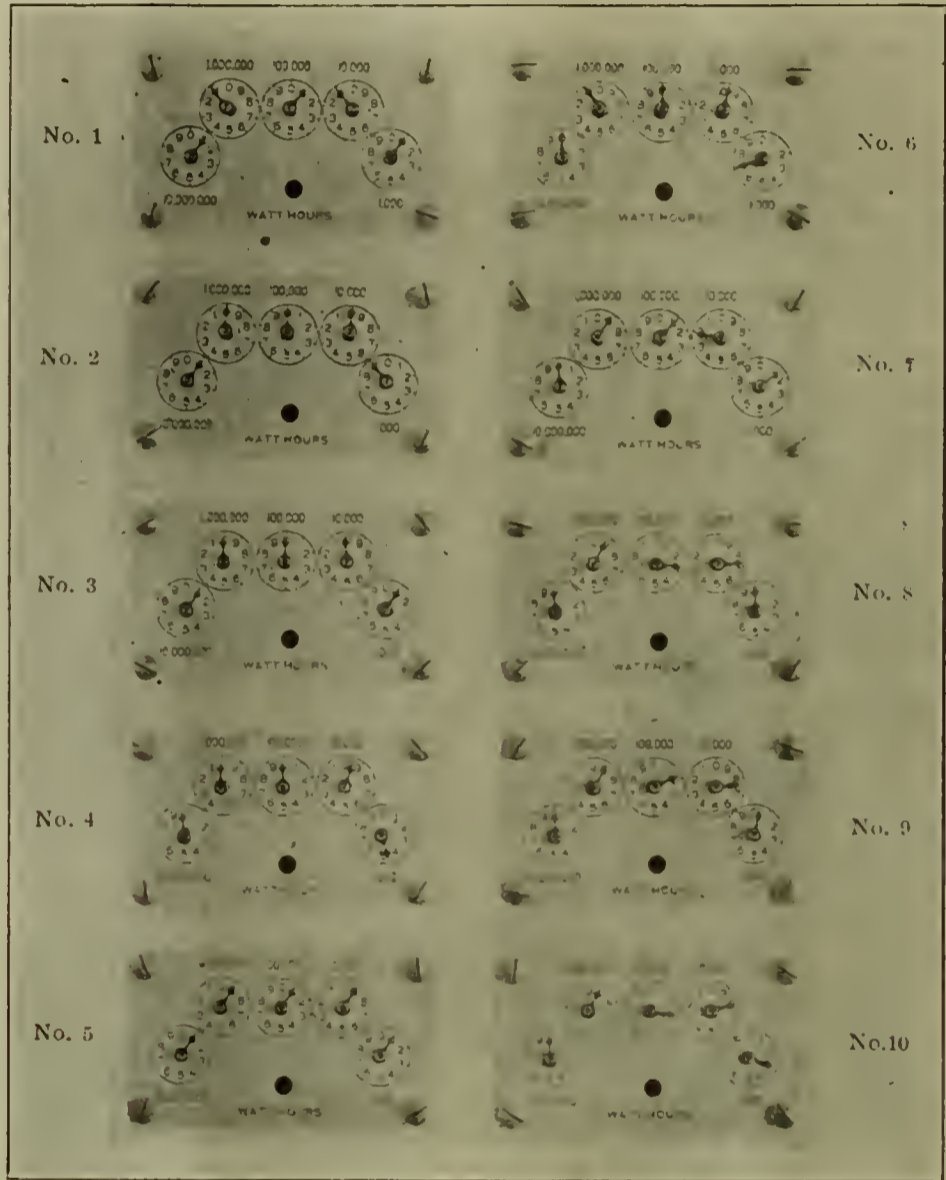

FIG. 2.—EXAMPLE OF DIAL READINGS, GENERAL ELECTRIC METER REGISTER.

accompanying examples of positions of the dial hands on General Electric registers, Fig. 2, in which, as already stated, the number marked near each dial indicates the value of the entire revolution on the dial.

The correct readings for the ten registers shown are as follows:

No. 1	.....	1,111,100
2	.....	999,900
3	.....	1,000,100
4	.....	9,999,500
5	.....	909,100
6	.....	99,700
7	.....	9,912,100
8	.....	9,928,000
9	.....	9,918,100
10	.....	9,928,300

shown are of the standard Duncan type in which the number marked over each dial denotes the value of each division on the dial:

“The values (1000s, 100s, 10s, 1s, Tenths) over the dial circles refer to the *divisions* of the circle over which they stand.

“Therefore, a division on the dial circle to the extreme right indicates one, two, three or four tenths of a kilowatt-hour, while a complete revolution of the hand or pointer would be 10 tenths or one kilowatt-hour, and will have moved the pointer on the second dial circle one division (one kilowatt-hour).

“Thus in reading dial No. 1, the

first dial circle (that on the extreme right) indicates 1 (one-tenth) the next (1s) indicates 1, the next (10s) indicates 1, the next (100s) indicates 1, and the remaining dial circle (1000s) also indicates 1, making the total reading or indication 1 1 1 1 .1 kilowatt-hours.

"A hand or pointer to be read as having completed the division must be confirmed by the dial before it (to the right). It has not completed the division on which it may appear to

then the reading will be 1000 kilowatt-hours.

"The hands are sometimes slightly misplaced. In dial No. 8 the first dial circle (the extreme right) reads 0 (no tenths). The hand of the second dial is misplaced. As the first registers 0, the second should rest exactly on a division; therefore, it should have reached 8. The three remaining dials are correct and make a total of 9928.0 kilowatt-hours.

"In dial No. 9 the second dial hand

ous that it should meet with approval from the central-station managers.

"The following is an example of making out a bill on kilowatt-hour basis: Suppose the dial reading is 21.8 kilowatt-hours at 20 cents per kilowatt-hour or per 1000 watt-hours, which is the same thing, the amount will be  $21.8 \times 20 \text{ cents} = \$4.36$ . If the rate is 16 cents the amount will be  $21.8 \times 16 \text{ cents} = \$3.48$ . If the rate is 10 cents the amount of the bill will be  $21.8 \times 10 = \$2.18$ .

"If the dial has 'multiply by 10' marked on it, the reading must be multiplied by 10. Example: Dial reading 46.8 kilowatt-hours multiplied by 10 equals 468 kilowatt-hours."

The increase in the number of electric meters installed, on both old and new consumers' installations, has led to more or less systematic attempts to educate the public in reading meters and computing "bills for current," and some of the meter manufacturing and central-station companies have issued brief instruction cards or booklets on the subject couched in simple and non-technical language.

Two such publications are a small eight-page illustrated pamphlet entitled, "How to Read Your Electric Meter," issued by the General Electric Company (No. 3523, December, 1906), and a small 12-page illustrated pamphlet entitled, "Wattmeters and How to Read Them," issued by the Westinghouse Company (Folder 4032, July, 1907). Another and more extensive publication is a 56-page illustrated pamphlet entitled, "How to Check Electricity Bills," by S. W. Borden, published by the McGraw Publishing Company.

METER NUMBERING SYSTEMS.

In many central-station companies the factory numbers of the meters owned by the company are used in the records of the meter department. But where a large number of meters are in use by a company, it has been found desirable to renumber the meters in a consecutive series, going by the order in which they are bought. Thus a company owning a number of meters of different makes (the factory numbers of which are not, of course, consecutive) will apply a new number to each meter in a consecutive series from number 1 up, irrespective of the make, type or capacity of the meter.

While this renumbering plan facilitates in some degree the keeping of meter records, etc., as compared with dependence on the factory numbers of the meters only, the practice is growing of marking each meter on a numbering system designed to express at a glance not only the company's serial number of the meter, but also the make, type and capacity of the meter.

rest, unless the hand before it has reached or passed 0, or, in other words, completed a revolution. Therefore, it is always advisable to read dials from right to left.

"In reading dial No. 2, the first dial circle (to the extreme right) indicates 0.9 (nine-tenths). The second hand apparently rests on 0, but since the first rests only on 0.9 and has not yet completed its revolution, the second dial circle also indicates 9. This 9, placed before the 0.9 already obtained, gives 9.9. This is also true of the third dial circle. The second dial circle hand at 9 has not yet completed its revolution, so the third has not completed its division; therefore, another 9 is obtained, making 99.9. The same is true of dial circle four, thereby making the total reading 999.9 kilowatt-hours. When the hand on the first dial circle (extreme right) completes its revolution or reaches 0,

is misplaced, for since the first indicates 0.1 (one-tenth) the second should have just passed a division. As it is near to 7 it should have just passed that figure. The remaining three dial circles are approximately correct. The total indication is 9918.1 kilowatt-hours.

"In dial No. 10, the second dial circle hand is slightly misplaced by being behind its correct position, but not enough to mislead in reading. The total indication is 9928.3 kilowatt-hours.

"By carefully following these directions little difficulty will be experienced in reading the dials, even when the hands or pointers become slightly misplaced.

"These dials read direct in kilowatt-hours (thousands of watt-hours), and as this is the unit upon which the rate of charge is based, it is obvi-

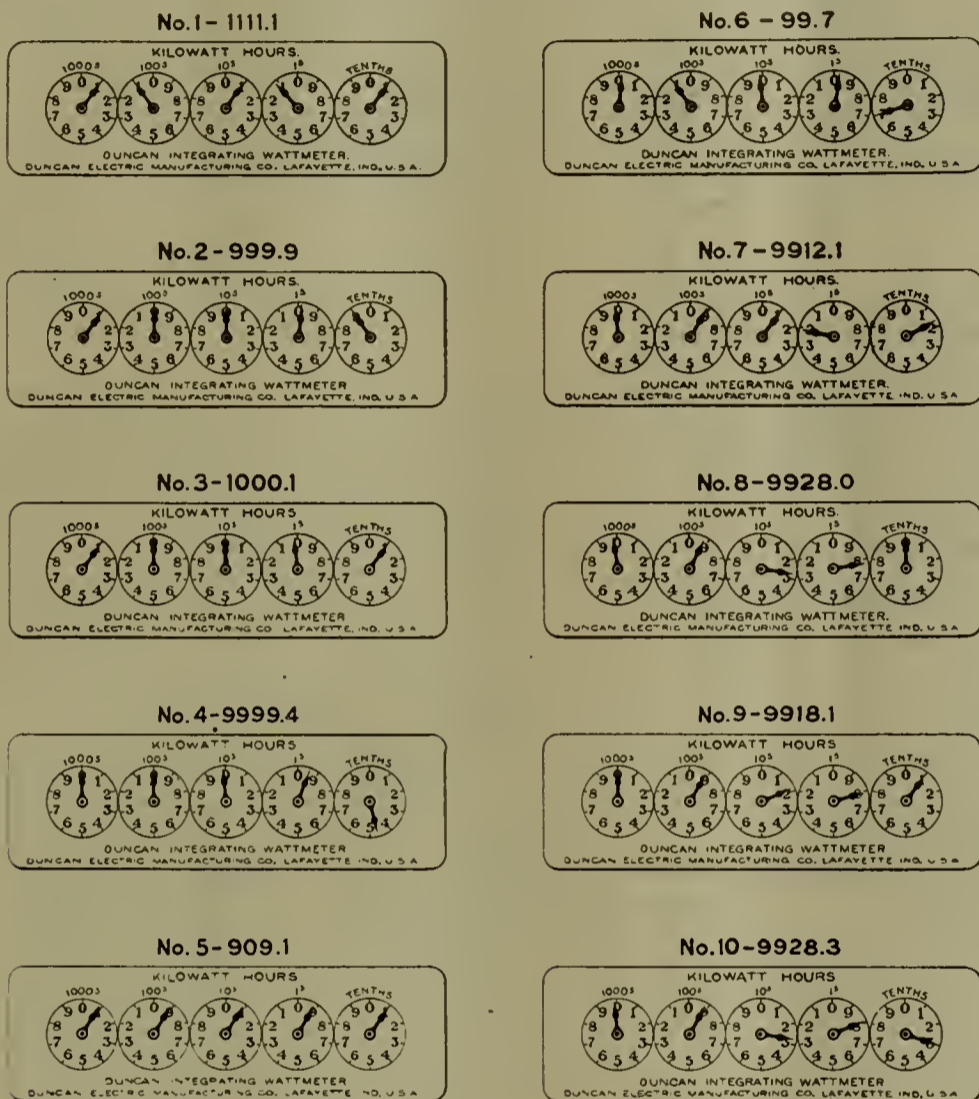

FIG. 3.—EXAMPLE OF DIAL READINGS, DUNCAN METER REGISTER.

Each meter number under this system is a composite number consisting of two parts separated by a symbol or letter referred to a code and designating the make of the meter. The first part is the serial number of the meter, in a series running from one up, for each make of meter owned by the company. The second part, called the "capacity number," consists of an arrangement of three digits referred to a code, and expressing in order the size, voltage and "wire" of the meter, respectively.

The following codes, which are used by certain central-station companies under this system for designating the symbols, and the three digits of the "capacity number," will serve to make the general method clear.

**SYMBOLS CONNECTING THE SERIAL NUMBER AND THE CAPACITY NUMBER.**

Make of Meter	Symbol
T R W Commutator Type.....	-
T R W Induction Type, Single Phase.....	+
T R W Induction Type, Polyphase.....	P
Stanley Recording Wattmeter.....	S
Fort Wayne Integrating Wattmeter.....	F

**FIRST DIGIT: CAPACITY OR SIZE OF METER**

Size, Amperes	Digit (Number or Letter)*
3	1
3½	2
5	3
7½	4
10	5
15	6
25	7
50	8
75	9
100	A
150	B
200	C
300	D

\*Letters are used for meters of capacities of over 75 amp., to avoid the use of two digits to designate these capacities.

**SECOND DIGIT: VOLTAGE OF METER**

Voltage	Digit
110	1
220	2
440	3
550	4

**THIRD DIGIT: "WIRE" OF METER**

Wire	Digit
Two-Wire	2
Three-Wire	3

The following table gives examples of this system of numbering:

Meter No.	Description of Meter
1120 - 523T R W	Commutator Type, 10-amp., 220 volt., three-wire.
15 + 112T R W	Induction Type Single-Phase, 3-amp., 110 volt., two-wire.
246 P 843T R W	Induction Type Polyphase, 50-amp., 440 volt., three-wire.
872 S 612Stanley	15-amp., 110 volt., two-wire.
1064 - B52T R W	Commutator Type, 150-amp., 550 volt., two-wire.

In some companies the "capacity number" is given first, and the "serial number" second; instead of the other way about as above described—the general scheme being otherwise unchanged. For meters having room on the cover, free from other markings, etc., the number may be painted or stenciled on—white-lead paint and a neat stencil gives good results—or may be embossed by machine on an aluminum plate which is then riveted to the cover.

The disk constant of the meter is

**METFR TEST**

Serial No.....Factory No.....District.....  
 Route.....Date.....  
 Customer's Name.....  
 Address.....  
 Premises Occupied as.....  
 Meter Location: Put up on.....  
 In.....  
 Occupied as.....

Meter.....Type.....Form.....Cat.No.....  
 Capacity.....Amp. Constants: Dial.....  
 .....Volts Test.....  
 .....Wire Bill.....  
 Potential.....Volts Seal Found.....

Circuit.....Wire.....Volts at Meter.....Phase   
 Load: Lamps..... 8 c.p.....16 c.p.....32 c.p..Special  
 Motors.....H.P.....Fans.....Arcs  
 Miscellaneous.....

Wattmeter No.....Voltmeter No.....Annmeter No.....  
 Milli-Voltmeter No.....Shunt No.....Stop Watch No..Sealing Tool No...

Time Arrived	As Found						
Per Cent of:	Volts	Amp.	Rev.	Sec'ds	Watts	Inst. Watts	Motor Per Cent Accuracy
Full Load							
5							
10							
25							
50							
100							

Time Left	As Left						
Per Cent of:	Volts	Amp.	Rev.	Sec'ds	Watts	Inst. Watts	Motor Per Cent Accuracy
5							
10							
25							
50							
100							

Lamps Required to start,before adj.....After Adj.....

Reason for Test.....

Adj. { A B C <sup>cc</sup> K D E F G J L M N P R S T V W X

Remarks.....

Test by..... Ass't

Last Test: Page No. Date



sometimes put on the cover also, where it forms a valuable part of the meter description which is of special assistance to the meter inspectors.

Among the advantages of this system of meter numbering may be mentioned the concise presentation of the information needed to identify the meter independently of other meters, and the assistance afforded to meter inspectors, to the stockkeeper and to the accounting department. The employes of the meter department soon accustom themselves to the system so as to identify the meter at a glance without removing the cover. The system is of special advantage in the stock room, as the stockkeeper can always tell quickly—as when determining on a requisition for new meters, or taking an inventory—the number of meters of all makes and sizes that are on his racks.

THE STOCKROOM.

In small companies the stock of meters may be kept on shelves in the common room appropriated to meter work. In many large companies a separate room is set aside as a stockroom and fitted with shelves and open racks to hold the meters, with lockers for meter parts, tools and supplies, and often for the company's equipment of testing instruments. As stated above, the orderly keeping of meter stock is greatly facilitated by the use of a serial numbering system for the company's meters.

The shelves and lockers should be kept clean and neatly painted, and the stock—which of course is constantly changing—should be arranged so that the stockkeeper always knows how it stands. The ideal should be the keeping of the stock in clean shape, with a minimum number of idle, inoperative and out-of-date meters on the shelves or lying about on the benches of the repair shop, yet in such condition that a rush requisition may always be filled.

The stock record generally takes the form of a card index, as described under Office Routine.

CLERICAL MANAGEMENT AND RECORDS.

The clerical management and records of meter stock, and of the installation, regular and special reading, and regular and special testing of meters, are handled in different ways, according to size and organization of the individual companies and the preferences of their officials. The brief remarks herein have been prepared to indicate merely the general scope of this routine and a few of the actual methods that are employed by different central-station companies.

Printed blanks are employed for the

meter readers' and inspectors' use, in the form of a book, loose slips or cards.

The following are typical forms of printed pages of meter inspectors' books, each laid out for a single test:

The form marked No. 1 contains spaces for test observations only. In order to simplify the record of the inspectors' work upon the meter, code letters are provided under "Adj." (ad-

tions made with the test meter (T. M.). It is made up with alternative entries, and the inspector is instructed to check what he has found or had to do in the meter, and to cross off what he has not found or had to do. This particular record shows that the dial constant is 2, that the inspector who last opened the meter was No. 6 (seal), and that the dial mechanism was tested to make sure that the gear-

Meter Test DATE Aug. 16-07

NAME J. Brown  
 ADDRESS 400 Washington St.  
 METER NO. 31100 15 AMP. 230 VOLTS 3 WIRE

---

**As Found**

READING 715 DIAL K 2 SEAL NO. 6  
 DIAL OK. DISK K. — TOP BEARING high, low, O. K.  
 CREEP continuous, occasional, RATE  
 DUE TO Passing vehicles FOR 10 HRS. PER DAY

JEWEL good, cup diamond, sapphire BRUSH TENSION RIGHT medium, heavy, light LEFT medium, heavy, light

(this section for indicating instruments)				REVOLUTIONS		% of actual energy recorded by consumer's meter Correct rev. of T. M. Actual rev. of T. M.
AMP.	VOLTS	SECONDS		CONSUMER'S METER	TEST METER	
		Correct	Actual	Correct	Actual	
<u>1.25</u>				<u>1</u>	<u>20</u> <u>25.</u>	<u>80.0</u>
<u>"</u>				<u>"</u>	<u>"</u> <u>25.</u>	<u>80.0</u>
<u>15</u>				<u>8</u>	<u>10</u> <u>10.2</u>	<u>98.0</u>
<u>"</u>				<u>"</u>	<u>10</u> <u>10.15</u>	<u>98.5</u>

---

**As Left**

<u>15.</u>				<u>8</u>	<u>10</u> <u>9.9</u>	<u>101.</u>
<u>"</u>				<u>"</u>	<u>"</u> <u>9.95</u>	<u>100.5</u>
<u>1.25</u>				<u>1</u>	<u>20</u> <u>20</u>	<u>100.</u>
<u>"</u>				<u>"</u>	<u>"</u> <u>19.8</u>	<u>101.</u>

JEWEL cup diamond, sapphire BRUSH TENSION RIGHT increased, decreased LEFT increased, decreased  
 ADJUSTED magnet, shunt coil, top bearing INSTALLED top magnet  
 CLEANED commutator, brushes, magnet CREEP None SEAL NO. 8

HOW TESTED normal connection, one ammeter or one test meter, on one field.  
normal connection, two ammeters or two test meters, fields per field.  
 INSTRUMENT NO. 152 TIME OF TEST 10:00 TO 10:40  
 TESTER John Smith HELPER \_\_\_\_\_

If it is necessary to make diagram, remarks, etc., reverse carbon and write on back of yellow sheet.

NO 2.

justments), referring to the different parts of A. C. and D. C. meters, and the inspector indicates the parts which he has had to adjust by checking with his pencil the proper letter.

No. 2, which is a filled-in form, contains space for the dial reading as well as for the test observations, and is designed to reduce as far as possible the number of entries, i. e., the amount of writing required of the meter inspectors. The form is laid out primarily for recording observa-

ing connecting with the meter shaft was "in mesh," and whether all the wheels and hands were tight on their individual shafts. There was no constant (K) marked on the disk, the meter being of the style having the disc constant the same as the dial constant. The top bearing was found "low," which should indicate to the tester that it should be raised (after As Found test). The meter crept occasionally, as stated, and a "clip" creep retarder had to be installed on the disk. The

tension of the left-hand brush was found to be too light and was increased. The jewel was reported—of course, upon examination after the As Found figures were obtained—to be a sapphire and in bad condition. The remaining entries will be clear upon examination. The columns in which no entries appear are provided for the use of the form in testing with indicating instruments. These forms are furnished to the inspectors in manifold books consisting of 50 white leaves, perforated for ready removal and constituting the originals, alternating with 50 colored leaves bound securely to give the carbon copies, and numbered consecutively from 1 to 50. This scheme has the advantage that it calls for some marking of each and

mounted on stubs and fastened together in books. The larger card (Fig. 5) contains the meter department record of changes in service and adjustment, and gives the complete service history of the meter, including dates of receipt and installation, length of service, idle periods in the stock-room or repair shop, and performance in service. It has space for six entries, which enable the single card to cover a period of three to six years, according to the frequency with which changes are made in adjustment and installation.

These original records are arranged to be filed at the office of the meter department. The tendency is toward the use of index cards of standard sizes rather than a book, or

primarily for billing, but also to head the card containing the consumer's monthly and special dial readings ("meter-record card"), and to head other cards for insertion in other indexes. The keeping of the meter-record cards in order in the files of the clerical section may be facilitated by indenting the edges of the card with a punch. The card of a given district and meter-inspection route are all indented at the same distance from the top of the card, so that in a group of cards for a given route, the indentations come in line when the cards are racked evenly. Thus a mistake in filing any card with cards of another group shows plainly by the offset of the misplaced card's indentation. The contract notice is then turned over to the construction department as an order to install the meter, and when the installation has been made comes back with the installation order attached and the number of the meter written on the back.

The meter readers transcribe the dial readings to the meter-record cards. They turn in a daily report, with the meter-record cards for the day. Complaints are transmitted via the district office.

The practice of another large company in 1905 is given in the following quotation from an article entitled, "The Meter Department of the New York Edison Company," in the *Electrical World and Engineer*, April 1, 1905: "After this test (the test that is made upon receipt of meter from manufacturer) has been completed and proper entry made in the record of the meter department, the meter is again returned to the storeroom to await installation in a consumer's premises. The contract and inspection departments being conversant with the demand of the customer, assigns the meter size and its location, and advises the distribution department when the installation has been approved by the Board of Fire Underwriters. The meters are installed by the distribution department, a meter of proper capacity being obtained from the storeroom, and the latter notifies the auditing department of the withdrawal of the meter from stock. When the meter has been installed, the contract and inspection department is notified by the distribution department. The former then advises the auditing department that the meter has been officially connected, and a new entry is then made for billing purposes in the records of the latter department. Prompt advice of this installation and connection is made to the meter department, which is thereby enabled to make a regular inspection of the meter within one week after it has been

METER TEST

METER NO. 215180

AT FROM 2 James St.

TYPE DC	MAKE W. E. Mfg. Co.	AMPERES 10	VOLTS 100	CONSTANT
WATTS 1000	POWER FACTOR	REVOLUTIONS 2.5	TIME 60.8	% SLOW 1.3
100		2.5	63	5

CONDITION OF METER ok except on light load

TESTED BY J. D. Simpson

DATE OF TEST

ENTERED ON METER

FIG. 4.—METER-RECORD CARD FILLED IN BY INSPECTOR AT CONSUMER'S INSTALLATION.

METER CARD CARD No. 16012

METER NO. 215180 DATE INV. 3/1/04 MAKE W. E. Mfg. Co. TYPE DC

MFR'S. NO. 215180 AMP. 10 VOLTS 100 CONST.

	DATE	ADDRESS CAUSE	INDEX	TEST				READJUSTED
				TRUE WATTS	REV.	TIME	PER CENT REGISTRATION	WITHIN PER CENT
INSTALLED	3/1/04	2 James St.	111	1000	2.5	59.9	100.2	
REMOVED	1/25/05	"	0	100	2.5	57.9	100.2	
REMOVED	1/25/05	"	346	1000	2.5	60.2	99.7	Too
INSTALLED	1/30/05	"	"	100	2.5	61.8	97.0	
REMOVED	1/30/05	"	"	1000	2.5	59.9	100.2	
REMOVED		"	"	100	2.5	54.8	100.3	
INSTALLED								
REMOVED								
INSTALLED								
REMOVED								
INSTALLED								
REMOVED								

FIG. 5.—METER-RECORD CARD CONTAINING RECORD OF AVERAGES IN SERVICE.

every item, and any omission is readily detected by the inspector himself by a look over the form before leaving the customer's premises.

Another record system is shown in Figs. 4 and 5, which are facsimiles of meter-record cards furnished by the Westinghouse Electric & Mfg. Company. Fig. 4 shows card of the standard three by five-inch size, which is filled in by the inspector at the consumer's installation. The cards are

loose slips, especially in the larger companies, on account of the recognized advantages of the card-index system of filing.

The following general clerical routine is followed in some large companies: When the contract notice, duly approved, comes down to the meter department from the general office, an addressograph stencil is prepared, containing the customer's complete address. This stencil is used



Record of diamond-jewel installation, giving meter description, customers' names and addresses, data of load, date at which the original sapphire jewel was replaced by a diamond jewel, and data constituting the history of the diamond in service. Card is shown in Fig. 11.

No.		Size		Constant		
INST.	READING	FEM.	READING	REVOLUTIONS		

FIG. 11.—METER-RECORD CARD CONTAINING RECORD OF DIAMOND JEWEL PERFORMANCE.

2. A record of each meter reader's and meter inspector's work for determining the relative efficiency of the men and difficulty of the several meter-reading and meter-testing routes. As an illustration of what may be done in this direction with a minimum of clerical work, the following routine, employing the manifold-book form No. 2 described above, is in use with good results in at least one rather large company:

At the close of each day the inspector tears off the original (white) leaves and turns them in as the report of his day's work. These leaves, after being looked over by a person having that duty, are filed for future ready reference. The inspector retains the book with the colored leaves until 50 tests have been made and then turns it in. As each inspector's book, bearing his name on the outside, is filled in, it is given a number and filed in a pigeon-hole cabinet like that shown in Fig. 12, with a section or vertical row of pigeonholes for each meter inspector. Since each book contains 50 tests, the number of tests to the credit of each man is seen at a glance—in the illustration 400, 350 and 500, respectively—thus stimulating a healthy competition or rivalry among the several men. It is a good idea to shift the men around in the various districts so as to avoid any claim that a certain district is much more difficult than others. In practice, the pigeon-hole case might better be made to hold 20 books, or 1000 tests. On a given date, when one section is full, the books are removed to the record storage.

BILL COMPUTING.

Billing of consumers from the original records of the meter readers—either the marked facsimiles of the

meter dials or the records in actual figures already described—or from meter-record cards containing data transcribed from the original records, is performed by clerks at the office of the meter department or in the accounting department at the general office, according to the organization of the company.

In some large companies the consumer's bills are made out from a

ring the making out of bills from meter readings. The chart is redrawn, with changes, from a large chart furnished by the General Electric Company. The figures at the bottom are kilowatt-hours and those at the left are the amounts of bills in dollars and cents. The diagonals are different rates per kilowatt-hour, ranging from 5 cents to 30 cents.

Selecting the diagonal having the

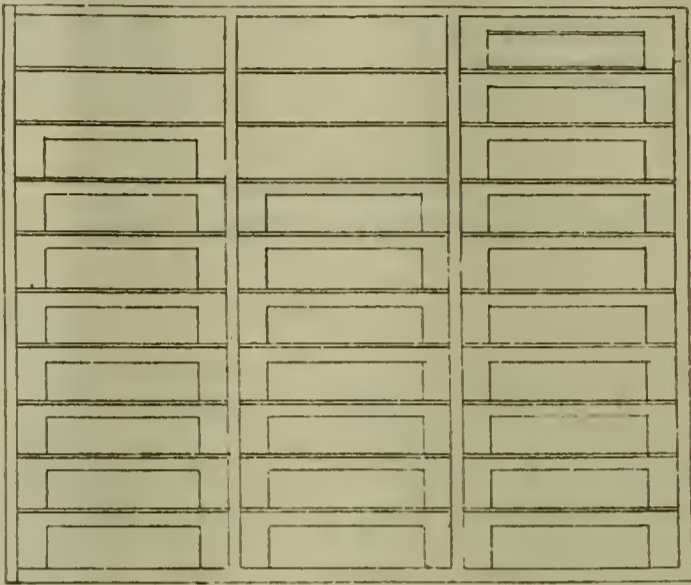

FIG. 12.—PIGEON-HOLE CABINET FOR METER-INSPECTOR'S BOOKS.

"consumer's meter-record sheet," which is filled in from data on meter-record cards. This sheet also contains columns for "net readings," computed either in the clerical section of

rate at which charges are to be made, a point is found on it directly over the number of kilowatt-hours shown by the meter. In the column at the left, on a horizontal line from the point re-

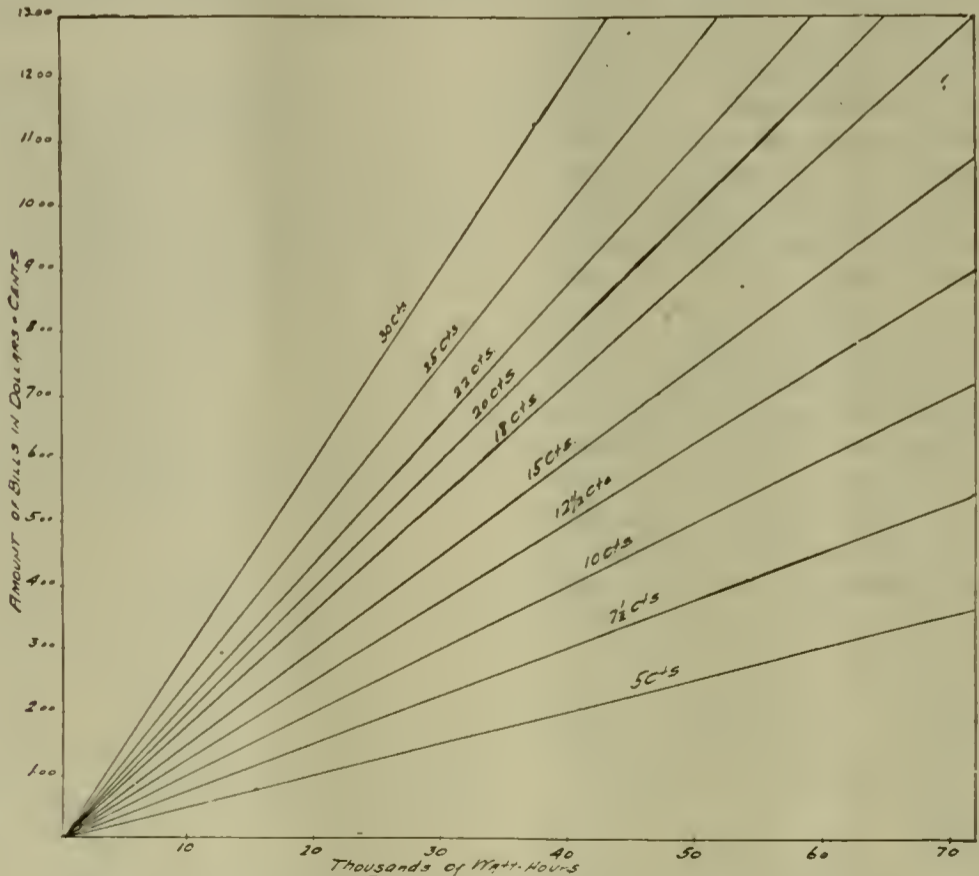

FIG. 13.—PRICE-CHART FOR COMPUTING BILLS FROM METER READINGS.

the meter department or in the general office, and is practically a ledger sheet, with one line for every (monthly) reading.

Fig. 13 is a price-chart for facilita-

ferred to, will be found the amount of the bill. For example, if the meter readings show a consumption of 50 kw-hr., and the rate is 10 cents per kw-hr., the amount of the bill is \$5.

# Cable Insulation

Compiled from Notes by W. A. Del Mar

## INSULATING MATERIALS.

THE principal materials used for insulating power cables are:

- (1) Paper saturated with oil.
- (2) Varnished muslin, variously known as varnished cambric or varnished cloth.
- (3) Compounds containing rubber.

The first two being made of staple commercial materials are generally reliable, but compounds containing rubber vary from the cheap material used for insulating "code wire" to the high-grade compound required by the U. S. navy.

## NECESSITY OF UNIFORM STRUCTURE.

If two conductors are arranged at such a distance apart that the air is just able to withstand for an indefinite time, say, 10,000 volts maintained by a transformer, and then a strip of glass introduced between them, the insulation will break down, although the glass has greater dielectric strength than air. The explanation is quite simple: the fall of volts per centimeter of air is the highest the air can withstand; as glass has a higher specific capacity the potential gradient in the glass is less steep than in the air, and the consequent increased steepness in the air punctures the latter. This experiment shows the necessity of having the insulation of uniform composition. This does not exclude "graded" cables; that is, those in which the small area in contact with the conductor is made dielectrically stronger than the peripheral areas.

## CALCULATION OF INSULATION THICKNESS.

This method is a modification of one suggested in THE ELECTRICAL AGE April, 1907, and is put forward tentatively in the hope that it will either receive approval or bring forth suggestions of improvement.

The variety of opinion as to the proper thickness of insulation to be used shows that this matter is not treated in a scientific way. The method of calculating the proper thickness, given below, while probably susceptible of improvement, is certainly much better than the haphazard guessing often employed.

## THE THICKNESS OF INSULATION.

The thickness of insulation to be placed on a wire is governed by three features:

1. Errors in size of wire, eccentric situation of wire in the insulation, and similar irregularities.

2. Insulation not to be strained by application of test voltage.

3. Insulation to be thick enough to have mechanical strength.

## ERROR THICKNESS.

The thickness of insulation required to make up for errors and irregularities of manufacture may be termed the "Error Thickness." This quantity depends both on the size of wire and on the thickness of insulation. While no exact expression of error thickness is possible, experience has shown it to be proportional to the square root of the wire diameter and proportional to the thickness of insulation. For rubber insulation the following empirical formula represents good practice:

$$\text{Error Thickness (inch)} = 0.01t + 0.07\sqrt{D}$$

where  $D$  = diameter of wire, inches

$t$  = thickness of insulation, inches.

Thus, for a No. 0000 B. & S. with 0.28 in. of insulation,

$$\begin{aligned} E &= (0.01 \times 0.28) + (0.07\sqrt{0.46}) \\ &= 0.0028 + 0.0475 \\ &= 0.0503 \end{aligned}$$

The formula may be more conveniently written:

$$E = 0.01t + 0.098\sqrt{r}$$

where  $r$  is the radius of the wire.

## DIELECTRIC STRESS.

When a high potential is established across the insulation of a cable, the insulation is subjected to a strain which depends upon the degree of concentration of electric force. When this concentration reaches a certain value, the insulation will no longer be able to stand the strain and will break down. It will not necessarily be punctured, but will be disintegrated only where the concentration of electrical force has been excessive. For purpose of analysis, it is usual to represent the intensity of electric force by the density of imaginary lines of force stretching radially from wire to sheath.

Let  $F$  = electric force or dielectric strain

$V$  = Test potential, kilovolts

$t$  = thickness of insulation, inches, over error thickness.

then  $F = \frac{V}{t}$  where the electric force is uniform.

The electric force around a cylindrical-

al wire, however, is not uniform, the lines extending radially from the wire to the outside of the insulation. The density of the force lines is therefore greater at the surface of the wire than at the outside of the insulation. This explains the well-known fact that small wires insulated for high potentials often show a disintegration of the inner layers of insulation without any visible defect on the outside. In this case

$$F = \frac{.434V}{r \log \frac{t+r}{r}}$$

where  $r$  is the radius of the wire, inches, and the logarithm is to the base ten.

$$\text{This gives: } V = 2.3026 F.r.\log. \frac{t+r}{r}$$

This is not strictly true for stranded cables, the dielectric stress being from 1.23 to 1.46 times the value given by the above formula.

The smaller value holds for thick insulation and the latter for very thin insulation.

(The exact formula for stranded cables, according to Professor Levi-Civita, is given by E. Jona in the Transactions of the International Electrical Congress at St. Louis, 1904.)

Owing to the individual wires of a multiplex cable being pressed together in assembling, the voltage test between cables should be slightly less than double that on a single cable. Ten per cent. is taken as a conservative amount for the loss due to this.

## ELECTRICAL THICKNESS.

The error thickness being known, the *electrical thickness*, or thickness required to withstand the electrostatic stress, may be calculated with the aid of the logarithmic formula, above.

The thickness of insulation adopted for potential differences up to about 1000 volts is determined solely by mechanical considerations, the dielectric stress not being concerned.

## MECHANICAL THICKNESS.

The error thickness and electrical thickness of insulation are often insufficient for mechanical reasons. Fig. 1 shows the minimum thickness of insulation which is permitted by mechanical considerations. Unlike the electrical thickness, which is added to the error thickness, the mechanical

thickness is a total figure which includes everything. This graph, while based on average practice, may not meet the requirements of some engineers, and should, therefore, be carefully examined before it is used.

INSULATION RESISTANCE.

The insulation resistance of a cable is derivable from the following formula:

$$M = 58 \times 10^{-7} \times S \times \log \frac{T+r}{r}$$

where

- M=megohms per mile;
- S=specific resistance in megohms per inch cube;
- T=thickness of insulation inches.
- r=radius of wire, inches;
- logarithm is to base ten.

This formula is sometimes written

$$M = K \log \frac{T+r}{r}$$

where

$$K = 58 \times 10^{-7} \times S.$$

The value of K varies from 870 to 23,200 for S=150 and S=4000, respectively. The use of K instead of S has the advantage of brevity and is endorsed by the manufacturers.

Calculating insulation resistance, the total thickness of insulation should be used.

EXAMPLE OF CALCULATION.

It is desired to find the thickness of insulation for a cable to be tested for 15 kilovolts (using a stress of 96 kilovolts per inch), the size being No. 4-0 B. & S. stranded.

Fifteen kilovolts, with stranded cable, is equivalent to  $15 \times 1.3 = 19.5$  kilovolts with solid wire, say.

Then using the formula

$$\begin{aligned} \frac{.434V}{Fr} + \log r &= \log (t+r) \\ \frac{.434 \times 19.5}{96 \times .23} + \log .23 &= \log (t+r) \\ .383 + 1.361 &= \log (t+r) \\ 1.744 &= \log (t+r) \end{aligned}$$

whence,

$$(t+r) = .556$$

$$t = .556 - .23 = .326$$

$$\begin{aligned} \text{Error thickness, } E &= .01t + .098\sqrt{t} \\ &= .00326 + .0475 \\ E &= .051 \text{ approx.} \end{aligned}$$

$$\begin{aligned} \text{Total thickness, } T &= .051 + .326 \\ &= .377 \\ &= \frac{24}{64} \end{aligned}$$

The megohms per mile, assuming K=4000, are:

$$\begin{aligned} M &= 4000 \log \frac{.377 + .23}{.23} \\ &= 4000 \times .421 \\ &= 1684 \end{aligned}$$

In the above case the thickness is well above the amount required for mechanical strength, which would be about  $\frac{6}{64}$  inch. If the thickness had worked out to an amount less than is required for mechanical strength, the proper thickness would have to have been taken from Fig. 2.

In such cases the error thickness has to be calculated and subtracted

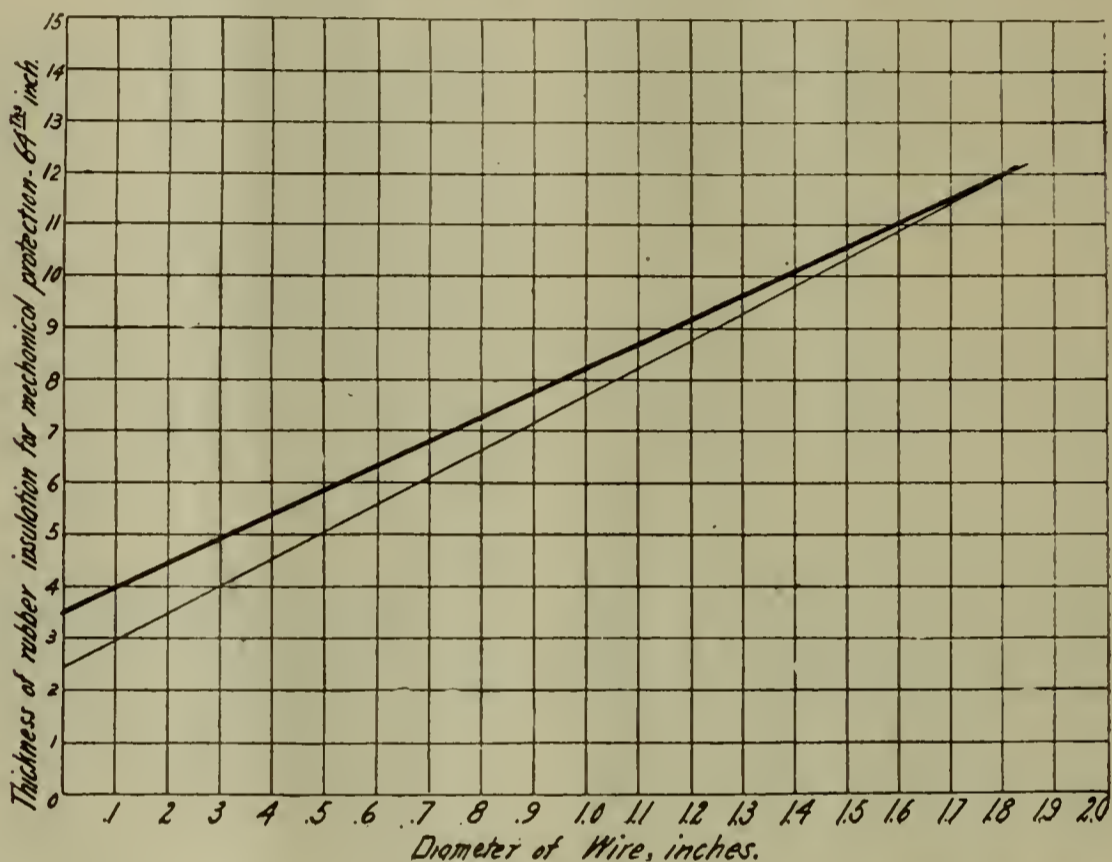

FIG 1.—UPPER CURVE REPRESENTS CONSERVATIVE PRACTICE; THE LOWER ONE, THE LEAST THICKNESS ALLOWABLE

from T in order to obtain t, for which the test voltage is calculated.

RUBBER INSULATION.

- 127 kilovolts per in., conservative testing stress.
- 56 kilovolts per in., conservative working stress.
- 400 kilovolts per in., breakdown stress (approx.)

PAPER INSULATION.

General.

Paper ribbon is wound spirally around the conductor in numerous layers, until the desired thickness is obtained. The cable is then immersed in a bath of oily insulating compound, until saturated. The whole is then enclosed in a lead sheath, which not only serves to retain the compound, but also to exclude moisture.

This type of cable is cheaper than varnished cambric or good quality rubber, and is better able to stand high voltages than rubber insulation. It is almost universally used for volt-

ages from 5000 up, and is very largely used for lower voltages.

Owing to the hygroscopic qualities of paper insulation, it should not be used where the cable is exposed to the direct action of water, as, for example, in submarine work or in badly drained splicing chambers. For this service, rubber or varnished cambric insulation is to be preferred, as, in the event of a burn-out, the insulation will not be spoiled, except at the actual point of trouble.

Dr. Jona, Int. Elec. Congress, 1904, says that paper subjected to dielectric strain for an hour, with progressively

increasing voltage, will stand from eight to ten kilovolts per millimeter. These numbers represent good commercial averages, but it is not unusual to find paper with 20 or 30 per cent. greater dielectric strength.

THICKNESS OF INSULATION (PAPER).

“As the result of some fifteen years of experience with underground cables, the following table, giving thickness of insulation and lead sheath for various sizes of conductors and working pressures, is submitted as representing conservative practice:

TABLE 1.—PAPER INSULATION. STANDARD WORKING PRESSURE OF 3000 VOLTS.

SIZE OF CONDUCTORS	Thick-ness of Insula-tion	THICKNESS OF LEAD	
		Single Cond.	Three Cond.
No. 6 to No. 2 B. & S. . . . .	$\frac{1}{8}$ in.	$\frac{1}{8}$ in.	$\frac{1}{4}$ in.
No. 1 to No. 00 . . . . .	$\frac{3}{16}$ in.	$\frac{3}{16}$ in.	$\frac{3}{8}$ in.
No. 000 to 300,000 cm. . . . .	$\frac{1}{4}$ in.	$\frac{1}{4}$ in.	$\frac{3}{4}$ in.
400,000 to 750,000 cm. . . . .	$\frac{3}{8}$ in.	$\frac{3}{8}$ in.	.....
800,000 to 1,000,000 cm. . . . .	$\frac{1}{2}$ in.	$\frac{1}{2}$ in.	.....
1,250,000 to 2,000,000 cm . . . . .	$\frac{3}{4}$ in.	$\frac{3}{4}$ in.	.....

For each 1000 volts increase of pressure above 3000 add  $1/32$ -in. insulation to the wall until 11,000 volts is reached, and after that add  $1/64$ -in. for each 1000 volts. For example, the insulation required on a No. O B. & S. 25,000-volt cable would be 20-32-in. or  $5/8$ -in. If 35 per cent. para rubber compound or varnished cambric is used for insulation, the above empirical rule may be changed to read: for each 1000 volts increase above 3000, add  $1/64$ -in. insulation to the thickness of wall until 25,000 volts is reached. For the insulation of low-potential cables,  $4/32$ -in. paper should be used on all sizes up to 1,000,000 c. m., and from 1,250,000 to 2,000,000 c. m.,  $5/32$ -in. should be used.

From a purely electrical point of view, one-half of this insulation would be ample to withstand 650 volts working pressure, but the mechanical effects of reeling and unreeling the cable and pulling it into ducts and bending around the manholes, are to practically destroy the insulating qualities of the layer of paper next the lead, so that we really start in with a cable having approximately  $1/32$  in. of its insulation destroyed before it is put into commission; this mechanical destruction of insulation is especially marked in cold weather, as the oils used with the paper tend to congeal when subjected to a temperament below 32 degrees F. The cable manufacturers have met this difficulty by using more fluid oil, with the result that the insulation resistance of the cable may not be more than 50 megohms at 60 degrees F., but by the use of this very soft insulation they have produced a cable giving a very low insulation, but a high puncture test, and at the same time have met, to a great extent, the difficulty of handling paper cable in cold weather. It is always advisable, however, if a cable is to be used in a temperature below 32 degrees F., to keep it in a warm place, such as a boiler-room, for at least 12 hours before drawing it in.

The cable may then be used in the coldest weather, as it gives up its heat very slowly."

H. G. Stott, Oct., 1906.

FACTORS FOR CORRECTION OF INSULATION RESISTANCE TO 15.5° C.

Temp. Deg. Cent.	Factor for High Grade Paper
30	5.38
29	5.20
28	4.82
27	4.45
26	4.09
25	3.71
24	3.32
23	2.97
22	2.61
21	2.24
20	2.00
19	1.78
18	1.57
17	1.36
16	1.14
15.5 (60° F.)	1.00
15	.92
14	.78

VARIATION OF INSULATION RESISTANCE WITH TIME OF ELECTRIFICATION (PAPER INSULATION)

Time of Electrification, Minutes	Relative Insulation Resistance, Referred to Value after 1 Minute Electrification
0	1.00
0 1/2	1.824
1	1.00
1 1/2	1.09
2	1.16
2 1/2	1.21
3	1.24
3 1/2	1.28
4	1.31
4 1/2	1.33
5	1.35

This test represents average results, but must not be taken as correct for any particular cable.

#### VARNISHED CAMBRIC.

Prepared cotton fabric is coated on both sides with multiple films of insulating varnish. The coated cloth is cut into strips and wound spirally on the copper core, with films of non-drying viscous adhesive compound between the layers. A separator is sometimes applied between the copper core and the taping, in order to prevent any possible action of the varnished films on the copper.

This insulation, unlike paper, does not absorb moisture and may be used

for indoor work without a lead sheath. It is suitable for high-tension cables, especially where a lead sheath cannot be used, as, for example, when subjected to vibration. In such cases it is usual to protect the insulation by a spiral galvanized steel tape.

Cambric insulation is considerably more flexible than paper, it being possible to bend cables to a radius of six times their diameter, without injury. Unlike rubber-insulated cables, the insulation remains concentric with the core.

Other advantages of varnished cambric are that splices are simple, and that mineral oils have no effect on it.

#### RUBBER INSULATION.

Rubber insulation, so-called, is a compound of various substances in which rubber seldom predominates. It is, therefore, not surprising to find the properties of rubber compounds varying between very wide limits according to the nature of the substances of which they are composed, and according to the process of compounding.

The qualities which a rubber compound should possess, in order to fulfill all requirements as cable insulation, are as follows:

- (1) High dielectric strength.
- (2) High mechanical strength.
- (3) Fair elasticity.
- (4) Fair specific resistance.
- (5) Permanence or long life.

The first four qualities are not difficult to obtain, and it is easy to test a compound for their presence. The fifth quality, permanence, depends on

FACTORS FOR CORRECTION OF INSULATION RESISTANCE TO 15.5° C.

Temp. Deg. Cent.	Factor for Varnished Cambric
30	13.00
29	11.00
28	9.35
27	8.07
26	6.76
25	5.92
24	5.00
23	4.06
22	3.30
21	2.76
20	2.32
19	2.00
18	1.70
17	1.40
16	1.16
15.5 (60° F.)	1.00
15	.88

two conditions: The first of these is chemical equilibrium, *i. e.*, the rubber and substances associated with it must have no affinity for one another, for the conductor, for air or for moisture. The second condition is that the compound shall contain no substance tending to change its physical state, as, for example, a volatile or crystallizable substance.

Within wide limits compounds of various compositions can be made

#### INSULATION OF HIGH TENSION CABLES

COMPANY	Line Voltage	Kind of Insulation	THICKNESS OF INSULATION IN THOUSANDTHS OF AN INCH			
			Between Conductors	Between Conductors and Ground	Per 1000 Volts	
					Between Conductors	Between Conductors and Ground
New York Edison.....	6,600	Paper	312	312	47	47
New York Metropolitan.....	6,600	"	436	343	67	52
I. R. T. Subway (New York)...	11,000	"	436	468	40	43
Manhattan Ry. (New York)....	11,000	"	436	436	40	40
New York Central R.R.....	11,000	"	437	406	40	37
Buffalo—Niagara Line.....	11,000	Varnish	375	375	34	34
Chicago Edison.....	9,000	Paper	406	406	37	37
Milwaukee.....	15,000	Rubber	562	281	51	25
St. Paul.....	25,000	"	406	383	44	38
St. Paul.....	25,000	Paper	500	437	33	29
Providence.....	12,500	"	562	484	22	19
Montreal.....	25,000	Rubber	436	374	17	15
		"	562	281	45	22
		"	562	406	22	16

\*This varnish cambric cable has a double steel tape without lead and is used in pipes on elevated structure.

THICKNESS OF VARNISHED CAMBRIC (SINGLE CONDUCTOR)

WORKING VOLTAGE	1000 Volts or Less	3000 Volts or Less	5000 Volts or Less	7000 Volts or Less	15,000 Volts or Less
	Test Volts 3000	Test Volts 7500	Test Volts 12,500	Test Volts 17,500	Test Volts 33,000
6 B. & S.	1/16	3/32	1/8	3/16	1/4
4	1/16	3/32	1/8	3/16	1/4
2	1/16	3/32	1/8	3/16	1/4
1	1/16	3/32	1/8	3/16	1/4
0	1/16	3/32	1/8	3/16	1/4
00	1/16	3/32	1/8	3/16	1/4
000	1/16	3/32	1/8	3/16	1/4
0000	1/16	3/32	1/8	3/16	1/4
1/4 M. C. M.	1/16	3/32	1/8	3/16	1/4
3/4 M. C. M.	1/16	3/32	1/8	3/16	1/4
1 M. C. M.	1/16	3/32	1/8	3/16	1/4
1 1/4 M. C. M.	1/16	3/32	1/8	3/16	1/4
1 1/2 M. C. M.	1/16	3/32	1/8	3/16	1/4
2 M. C. M.	1/16	3/32	1/8	3/16	1/4

These are the figures recommended by the G. E. Co.

THICKNESS OF VARNISHED CAMBRIC (TRIPLE CONDUCTOR)

SIZE	WORKING VOLTAGE					
	1000 or Less	3000 or Less	5000 or Less	7000 or Less	10,000 or Less	15,000 or Less
	TEST VOLTAGE					
	3000	7500	12,500	17,500	25,000	33,000
	Inches	Inches	Inches	Inches	Inches	Inches
6	1/16 - 1/32	3/64 - 3/64	3/32 - 3/64	1/8 - 1/8	3/16 - 3/16	1/4 - 1/4
4	1/16 - 1/32	3/64 - 3/64	3/32 - 3/64	1/8 - 1/8	3/16 - 3/16	1/4 - 1/4
2	1/16 - 1/32	3/64 - 3/64	3/32 - 3/64	1/8 - 1/8	3/16 - 3/16	1/4 - 1/4
1	1/16 - 1/32	3/64 - 3/64	3/32 - 3/64	1/8 - 1/8	3/16 - 3/16	1/4 - 1/4
1,0	1/16 - 1/32	3/64 - 3/64	3/32 - 3/64	1/8 - 1/8	3/16 - 3/16	1/4 - 1/4
2,0	1/16 - 1/32	3/64 - 3/64	3/32 - 3/64	1/8 - 1/8	3/16 - 3/16	1/4 - 1/4
3,0	1/16 - 1/32	3/64 - 3/64	3/32 - 3/64	1/8 - 1/8	3/16 - 3/16	1/4 - 1/4
4,0	1/16 - 1/32	3/64 - 3/64	3/32 - 3/64	1/8 - 1/8	3/16 - 3/16	1/4 - 1/4
250,000	3/32 - 3/64	3/32 - 1/16	3/32 - 3/32	1/8 - 1/8	1/16 - 1/16	1/16 - 1/16

The first column in each group is the thickness of insulation on each conductor, and the second is the thickness over all. These figures are recommended by the G. E. Co.

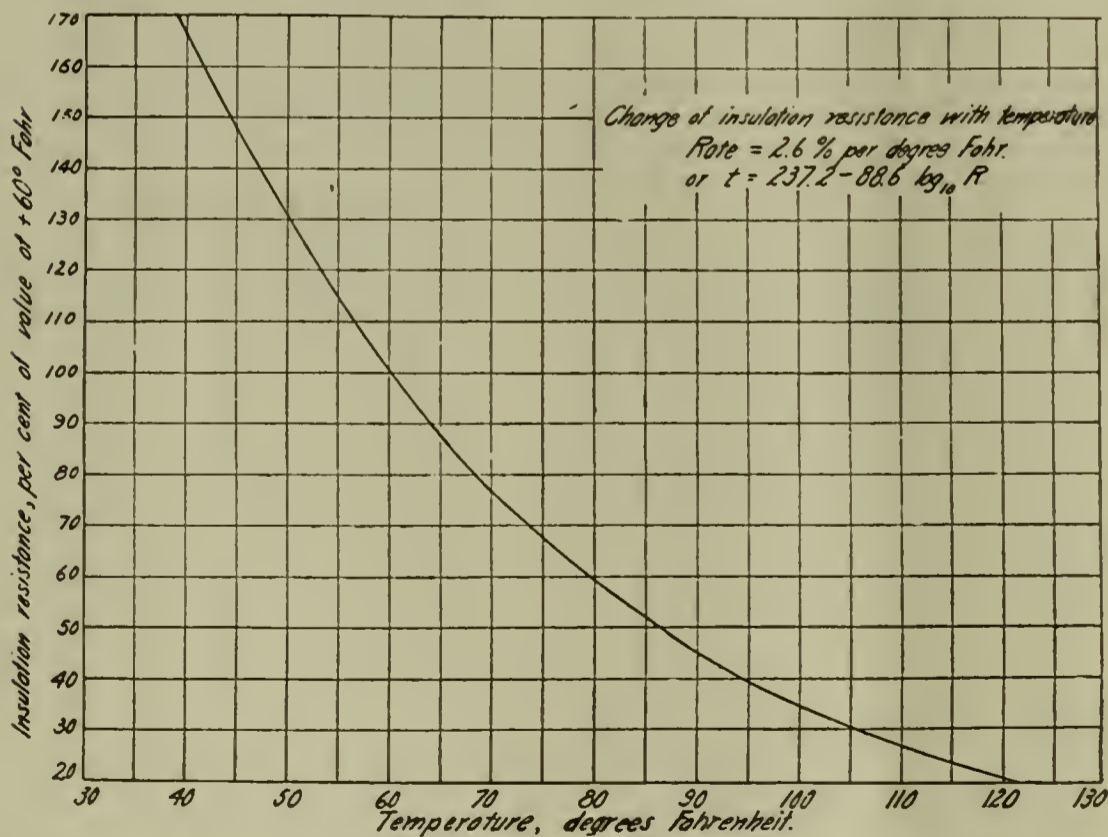

CURVE SHOWING CHANGE IN INSULATION RESISTANCE DUE TO HEAT.

FIG 2.—THE VALIDITY OF THIS CURVE AT TEMPERATURES ABOVE 80° FAHR. HAS BEEN QUESTIONED BY SEVERAL OBSERVERS, BUT NO ACTUAL DATA HAVE BEEN PRODUCED.

balanced and, therefore, permanent, provided that conditions inconsistent with the condition of balance are not specified. There are no known tests which will infallibly distinguish between a balanced and an unbalanced

compound. A short discussion of the tests and restrictions which have been suggested for this purpose is given below.

RUBBER GUM.

Rubber is a gum extracted from a tree which grows in the tropical countries of Africa and South America. The quality of this gum varies in many ways, but the characteristic which most affects its commercial value is the amount of resinous extract which it contains. The amount of extract is usually estimated by digesting the gum in acetone for several hours, and thereby dissolving out the extract. The proportion of acetone extract in different grades of gum varies from less than 1 per cent. to over 20 per cent., the grades having the smaller proportion of extract being generally from South America.

The best grade of South American rubber is known as fine Para, and is the most desirable kind to use in insulating compounds. While it is usual to specify that compounds shall contain only the finest dry Para rubber, there is no practical way to ascertain whether the rubber did actually come from Para. Furthermore, it is of no practical import whence the rubber is from, provided that the percentage of extract does not exceed, say, 3 per cent. A greater percentage of extract indicates a cheap grade of rubber, which it is difficult to manufacture into a balanced compound.

VULCANIZATION.

Rubber gum, in its native state, is of little use for insulating purposes, owing to its property of absorbing water and oxidizing. When mixed with sulphur and heated to a temperature of from 248 to 302 degrees fahr., a combination takes place which renders the rubber more stable and at the same time increases its mechanical and electrical strength. This process is known as vulcanization.

COMPOUNDING.

It has been found by experience that 60 to 70 per cent. of adulterant may be added to rubber gum without destroying its useful qualities after vulcanization. Above this percentage, the qualities of the rubber cease to predominate, and the compound partakes markedly of the characteristics of the adulterant. It is for this reason that 30 per cent. pure rubber is generally adopted as the standard proportion, and that 40 per cent. pure rubber is required for shipboard work in the navy, the larger proportion being adopted as a special precaution on account of the necessity of absolute reliability.



TENSILE STRENGTH.

A good 30 per cent. Para compound, properly vulcanized, should show a tensile strength of at least 800 pounds per square inch. This figure is agreed to by practically every manufacturer of rubber compound in the United States, but the proportion of compounds which actually show this tensile strength is small.

A sample should be cut so that the ends gripped shall be considerably larger than the center, where the break should occur. The sample should be bent slightly, in every direction, before testing, in order to magnify and reveal any surface incisions which might reduce the total cross-section.

SET AFTER STRETCHING.

When stretched three times its original length, a sample should show a set not greater than 18¾ per cent. after a stated time has elapsed. Although the time is a matter of controversy, this percentage set is agreed to by all the leading manufacturers.

Nevertheless, it is well known that certain excellent compounds entirely fail to meet the regular stretch tests. It is, perhaps, better to lose the use of this class of compounds and take advantage of the selective action of the stretch test; and if this is done, it should be specified that the test may be performed by the purchaser at any temperature between 50 and 100 degrees fahr. It should also be specified that the sample tested shall not have been submitted to any previous stretching, because a sample with a permanent set will not show much additional set when further stretched. Stretching should be steady and release instantaneous.

SPECIFIC RESISTANCE.

The specific resistance of insulation sold as 30 per cent. Para compound varies between the enormously wide limits of 150 millions of megohms per inch cube and 4000 millions of megohms per inch cube.

From the standpoint of leakage, a mere fraction of the smaller value would be sufficient. It is, therefore, only as a test of quality that high megohms may be demanded, and the value of such test is open to doubt.

A minimum of 750 millions of megohms per inch cube is conservative, and there is nothing to be gained by specifying over 1200 millions of megohms per inch cube.

TEMPERATURE COEFFICIENT OF RESISTANCE.

The rate of change of resistance with regard to temperature should not exceed 2.6 per cent. per degree Fahrenheit. This is in agreement with

the tables used by the most reputable manufacturers. The object of specifying this quantity is twofold: First, to prevent the manufacturer using any temperature correction factor which will give a figure which complies with the specifications; second, as a measure of quality of the compound as pointed out by H. G. Stott, Proc. Am. Inst. Elect. Eng., 1906.

The writer's experience very strongly confirms Mr. Stott's opinion of the value of this test.

"HYSTERESIS TEST."

If extensions and retractions are plotted on a base of load, a complete "hysteresis" loop is obtained, as shown in Fig. 3. The area of this loop should generally be small in good compound; there are, however, exceptions to this rule.

SULPHUR.

Sulphur in rubber compound may be in three conditions:

- (1) free;
- (2) combined with rubber;
- (3) in barium sulphate.

Poor quality rubber requires a great deal of sulphur to vulcanize it, and is, therefore, often revealed by the large amount of combined sulphur.

Excess of free sulphur, say, over 1 per cent., usually indicates an unstable compound, as the sulphur is

liable to combine with the copper or tin coating over the copper.

PERCENTAGE OF RESINOUS MATTER

BRAND OF RUBBER	Resin in Washed Rubber. Per Cent.	Resin in Vulcanized Rubber. Per Cent.
Parafine.....	1.2	4.04
Ceara.....	2.1	5.12
Upper Congo.....	3.7	7.60
Lagos.....	4.5	7.13
Sierra Leone.....	6.1	9.97
Borneo.....	10.3	14.44

C. O. Weber, Chemistry of India Rubber."

COEFFICIENT OF VULCANIZATION.

C. O. Weber (Chemistry of India Rubber, London, 1903) defines the

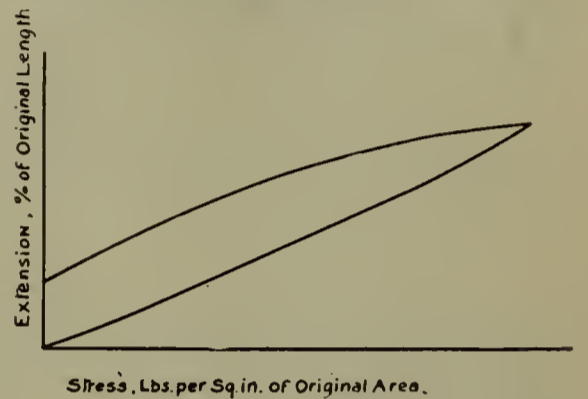

FIG—HYSTERESIS LOOP FOR RUBBER.

coefficient of vulcanization as the percentage ratio of amount to rubber and sulphur of vulcanization:

RUBBER INSULATION—INSULATION RESISTANCE AND PUNCTURE TESTS

30% RUBBER COMPOUND. MEGOHMS PER MILE. 60 DEG. FAHR. ONE MINUTE ELECTRIFICATION

	3/64	2/32	5/64	3/32	7/64	4/32	5/32	6/32	7/32
1,000,000 cir. mils.....					200	210	235	265	300
900,000 ".....					235	250	280	315	360
800,000 ".....					270	290	325	370	420
700,000 ".....					305	325	370	420	480
600,000 ".....					340	365	420	470	540
500,000 ".....				350	375	405	465	525	600
400,000 ".....				390	420	450	530	600	670
300,000 ".....				430	470	505	590	680	750
250,000 ".....				455	500	540	630	720	810
4/0 stranded.....			440	480	520	565	660	750	840
3/0 ".....			450	490	535	580	675	770	860
2/0 ".....			460	500	545	590	690	790	880
1/0 ".....			490	540	590	650	760	860	950
1 solid.....			520	580	635	700	830	950	1,060
2 ".....		500	550	615	680	750	900	1,040	1,160
3 ".....		530	585	650	715	795	940	1,080	1,210
4 ".....		560	620	690	750	830	990	1,130	1,260
5 ".....		590	655	720	790	870	1,040	1,180	1,300
6 ".....		620	690	760	840	920	1,100	1,230	1,350
8 ".....	610	710	800	880	985	1,060	1,240	1,370	1,490
9 ".....	650	750	850	940	1,050	1,130	1,310	1,440	1,560
10 ".....	690	795	905	1,000	1,120	1,200	1,380	1,510	1,620
12 ".....	750	870	990	1,110	1,250	1,370	1,540	1,680	1,790
14 ".....	800	930	1,060	1,200	1,340	1,470	1,640	1,780	1,890

30% RUBBER COMPOUND. VOLTAGE TEST FOR 5 MINUTES. FOR 30-MINUTE TEST TAKE 80% OF THESE FIGURES

SIZE	THICKNESS OF INSULATION											
	3/64	4/64	5/64	6/64	7/64	4/32	5/32	6/32	7/32	8/32	9/32	10/32
1,000,000 to 550,000.....					4,000	6,000	10,000	14,000	18,000	22,000	26,000	30,000
500,000 to 250,000.....				4,000	6,000	8,000	12,000	16,000	20,000	24,000	28,000	32,000
4/0 to 1.....			4,000	6,000	8,000	10,000	14,000	18,000	22,000	26,000	30,000	34,000
2 to 7.....		4,000	6,000	8,000	10,000	12,000	16,000	20,000	24,000	28,000	32,000	36,000
8 to 14.....	3,000	5,000	7,000	9,000	11,000	13,000	17,000	21,000	25,000			

W. S. Clark, Am. Inst. Elect. Eng., 1906.

EXTENSIBILITY

Coefficient of Vulcanization	Extension—Inches	
	Load, Lbs.	
1.78	.125	
2.14	.094	
2.87	.065	
4.44	.02	

The extension follows a straight-line law only with considerable loads.

EFFECT OF TEMPERATURE ON RUBBER.

(1) Loss of strength or cohesion.

Rubber with a low coefficient of vulcanization is liable to develop this defect, particularly if the time for vulcanization has been short.

(2) Hardening with brittleness.

Rubber may contain white substitutes (chlorosulphides), but more commonly is due to the presence of a

considerable amount of free sulphur.  
(3) *Stickiness and darkening in color.*  
Rubber containing mineral oils, large quantities of recovered rubber, or large proportions of sulphide substitutes.

PARA RUBBER.

Deg. Temp. Cent.	Properties
90-100	Slightly sticky.
145	Sticky, but slightly elastic.
150-160	Surface melts and rubber darkens.
170-190	Gradually melts.
240	Can be mixed up and thermometer easily pushed into the mass.
255	Appearance of decomposition and boiling.
340	Gas evolved, which burns with a luminous flame.

RUBBER INSULATION

Insulation Resistance and Puncture Tests (30% Para Compound)

LOW POTENTIAL, 600 VOLTS

B. & S. Gauge	Wall	Voltage Test for 1 Minute	Insulation Resistance
No. 14 to 8.....	$\frac{3}{8}$ in.	1,000	1,000 megohms per mile
" 6 to 2.....	$\frac{1}{4}$ "	1,000	1,000 " " "
" 1 to 4/0.....	$\frac{3}{16}$ "	1,000	1,000 " " "
250,000 to 500,000 cir. mils.....	$\frac{5}{16}$ "	1,000	750 " " "
550,000 to 1,000,000 ".....	$\frac{3}{4}$ "	1,000	500 " " "

MEDIUM POTENTIAL, 3,500 VOLTS

B. & S. Gauge	Wall	Voltage Test for 1 Minute	Insulation Resistance
No. 14 to 8.....	$\frac{3}{8}$ in.	5,000	3,000 megohms per mile
" 6 to 2.....	$\frac{1}{4}$ "	5,000	2,500 " " "
" 1 to 4/0.....	$\frac{3}{16}$ "	5,000	2,000 " " "
250,000 to 500,000 cir. mils.....	$\frac{5}{16}$ "	5,000	1,000 " " "
550,000 to 1,000,000 ".....	$\frac{3}{4}$ "	5,000	600 " " "

5,000 VOLTS WORKING PRESSURE

B. & S. Gauge	Wall	Voltage Test for 1 Minute.	Insulation Resistance
No. 4 to 4/0.....	$\frac{3}{8}$ in.	10,000	2,500 megohms per mile
250,000 to 500,000 cir. mils.....	$\frac{5}{16}$ "	10,000	1,500 " " "
550,000 to 1,000,000 ".....	$\frac{3}{4}$ "	10,000	1,000 " " "

11,000 VOLTS WORKING PRESSURE

B. & S. Gauge	Wall	Voltage Test for 1 Minute	Insulation Resistance
No. 4 to 4/0.....	$\frac{3}{8}$ in.	15,000	4,000 megohms per mile
250,000 to 500,000 cir. mils.....	$\frac{5}{16}$ "	15,000	3,000 " " "
550,000 to 1,000,000 ".....	$\frac{3}{4}$ "	15,000	1,500 " " "

B. & S. Gauge	Wall	Voltage Test for 1 Minute	Insulation Resistance
No. 4 to 4/0.....	$\frac{1}{2}$ in.	20,000	5,000 megohms per mile
250,000 to 500,000 cir. mils.....	$\frac{3}{4}$ "	20,000	4,000 " " "
550,000 to 1,000,000 ".....	$\frac{1}{2}$ "	20,000	2,500 " " "

B. & S. Gauge	Wall	Voltage Test for 1 Minute	Insulation Resistance
No. 4 to 4/0.....	$\frac{3}{4}$ in.	20,000	6,000 megohms per mile
250,000 to 500,000 cir. mils.....	$\frac{1}{2}$ "	20,000	5,000 " " "
550,000 to 1,000,000 ".....	$\frac{3}{4}$ "	20,000	3,000 " " "

J. Langan, Am. Inst. Elect. Eng., 1906.

The liquid obtained on heating becomes viscid on cooling, but it does not again solidify.

TENACITY AND TEMPERATURE

Temperature in Deg. Fahr.	Loss of Tenacity, Per Cent.
68	2
138	5
248	10
328	15
418	20
438	22
488	25

A. Schwartz, Journal Inst. E. E., 1907.

EFFECT OF OVER-MASTICATION OF RUBBER.

Rubber overworked in the masticator oxidizes very rapidly, yielding a much greater amount of extract than before mastication.

C. O. Weber, Journal of Society of Chemical Industry, 1903, p. 875 and p. 103.

EFFECT OF LIGHT ON RUBBER.

The action of light on rubber, whether vulcanized or unvulcanized, is an oxidizing action, but the oxidation is faster the lower the degree of vulcanization.

C. O. Weber, Journal of Society of Chemical Industry, 1903, p. 875.

DETERIORATION OF CONGO RUBBER.

The deterioration of Congo rubber is due to the presence of albuminous substances primarily. Coagulated albumin is not removed by washing, causing finished goods to be more or less brittle, according to the amount of albumin present.

C. O. Weber, Journal of Society of Chemical Industry, 1902, p. 712.

EXCESS OF LITHARGE.

Certain varieties of rubber do not become properly vulcanized when treated with sulphur only, but do so readily if a considerable proportion of litharge is present during the process. The effect of litharge, however, is to make the rubber brittle.

C. O. Weber, Journal of Society of Chemical Industry, 1903, p. 103.

RUBBER INSULATION

Insulation Resistance and Puncture Tests (30% Para Compound)

B. & S. Gauge	Rubber Wall	Voltage Test for 1 Minute	Insulation Resistance Per Mile
18	$\frac{1}{16}$ in.	1,000	3,000 Megohms
16	$\frac{1}{8}$ "	1,000	3,000 "
14	$\frac{3}{16}$ "	1,000	3,000 "
12	$\frac{1}{4}$ "	1,000	3,000 "
10	$\frac{5}{16}$ "	1,000	3,000 "
8	$\frac{3}{8}$ "	1,000	3,000 "
9	$\frac{1}{2}$ "	1,000	3,000 "
6	$\frac{5}{8}$ "	2,000	2,500 "
4	$\frac{3}{4}$ "	2,000	2,500 "
2	$\frac{7}{8}$ "	2,000	2,500 "
1	$\frac{1}{2}$ "	2,000	2,000 "
0	$\frac{3}{4}$ "	2,000	2,000 "
00	$\frac{1}{2}$ "	2,000	2,000 "
000	$\frac{3}{4}$ "	2,000	2,000 "
0000	$\frac{1}{2}$ "	2,000	2,000 "

J. Langan, Am. Inst. Elect. Eng., 1906.

# Compensators for Measuring Line Drop

ERIC A. LÖF

FOR large lighting systems it is often of great importance to keep the pressure constant at the various distributing centers. In order to do this it becomes necessary to know the distributing-pressure in the power-station so that the proper regulations can be made.

In earlier days it was customary to run independent pressure wires from each distributing center to the central-station. With long-distance lines, however, the cost of the pressure wires becomes excessive, and some other means had to be resorted to. For this reason the compensator is now-a-days used altogether. This apparatus serves to modify the reading of the station voltmeter without the use of pressure wires so that the reading corresponds to the pressure at the point of distribution. The compensator must be so connected and adjusted so as to allow for the resistance and reactance of the line for which it is used. It is necessary to provide such an electromotive force at the power-station so that the voltmeter under the influence of the compensator will give the same reading as if connected directly at the distributing point, independent of the current and the power factor. An electromotive force component must be obtained which is in proportion to and in phase with a line drop and also has the proper relations to the electromotive force in the power-station.

Compensators used for single phase or balanced two or three-phase systems are connected to one-phase only by means of a single current transformer. For unbalanced systems one compensator for each phase is used to advantage. For high pressures the use of potential transformers also becomes necessary.

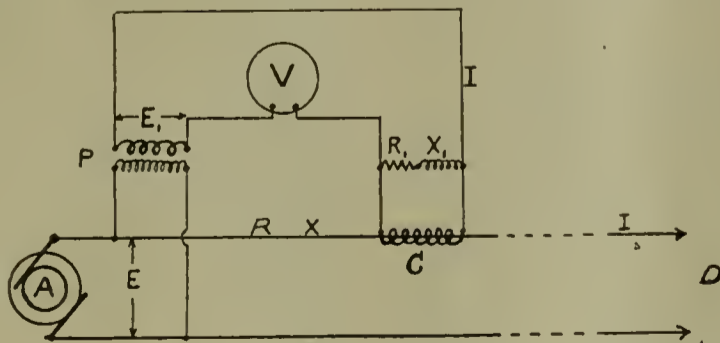

FIG. 1.

In Fig. 1 is shown a diagram for a compensator as used on a high-tension single-phase circuit.

A=Generator.  
P=Potential transformer.  
C=Current transformer.

V=Voltmeter.  
D=Center of distribution.  
R=Ohmic resistance of line.  
X=Reactance of line.  
R<sub>1</sub>=Ohmic resistance of compensator.  
X<sub>1</sub>=Reactance coil of compensator.  
E=Generator pressure.  
I=Current in the line.  
I<sub>1</sub>=Secondary current in current transformer.  
A is the generator in the central-station generating the pressure E.

X<sub>1</sub> in the compensator, it causes the same drop in the electromotive force of the voltmeter circuit as the line wires cause in the electromotive force of the load.

In the following is shown a method for determining the values of R<sub>1</sub> and X<sub>1</sub>:

If:  
R=Ohmic resistance of line  
X=Reactance of line  
I=Line current  
p=Ratio of potential transformer

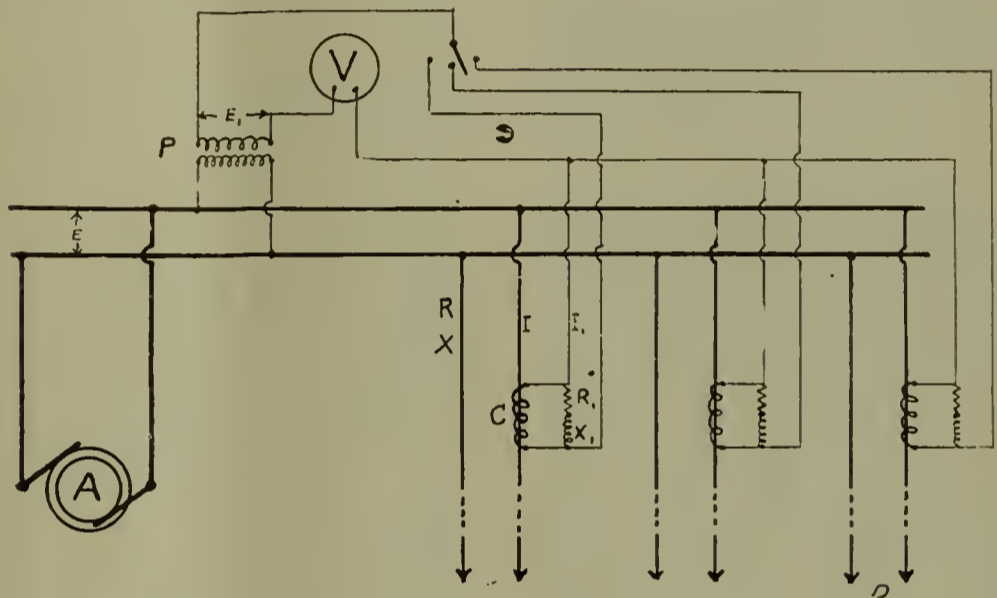

FIG. 2.

This pressure is reduced in the ratio  $E : E_1$  by the potential transformer P. In the same manner the current is transformed in the ratio  $I : I_1$  by the current transformer C. In parallel with the secondary circuit of this transformer is connected an ohmic resistance  $R_1$  in series with an induction coil of  $X_1$  ohms reactance. The ohmic resistance of the line is  $R$  and the reactance  $X$ . Then, by properly adjusting the resistance  $R_1$  and the reactance

$c$ =Ratio of current transformer, then

$$p = \frac{E}{E_1} \text{ and } C = \frac{I}{I_1}$$

$\sqrt{R^2 + X^2} = Z$  = Impedance of the line.

$\sqrt{R_1^2 + X_1^2} \cdot I_1$  = Voltage drop in the voltmeter circuit.

$$\frac{Z \cdot I}{Z_1 \cdot I_1} = \frac{E}{E_1} = p$$

$$\text{and } Z_1 = \frac{c}{p} \cdot Z$$

$$R_1 = \frac{c}{p} R$$

$$X_1 = \frac{c}{p} X$$

$\sqrt{R^2 + X^2} \cdot I$  = Voltage drop in the line.

$\sqrt{R_1^2 + X_1^2} = Z_1$  = Impedance of the voltmeter circuit.

From these last two equations the values of  $R_1$  and  $X_1$  can be calculated.  $E_1$  and  $Z_1 \cdot I_1$  are in phase with  $E$  and

Z.I and the reading of the voltmeter V is proportional to the pressure at the distributing point for every current and power factor in the line.

A great advantage of this system is that all apparatus is connected in the secondary circuits and that all danger from coming in contact with high-tension currents is thus eliminated.

If it becomes desirable to measure the pressure at more than one distributing center, this can easily be done by using one common potential transformer with voltmeter and a throw-over switch to connect the compensators for each outgoing line. One current transformer and one compensator is necessary for each line. Fig. 2 shows a diagram for this arrangement which explains itself.

An example will be given showing the method of calculating the compensator adjustment for a certain case:

**QUESTIONS AND ANSWERS**

Question.—*We have a shunt 110-volt motor running a blower. Accidentally, when working at the rheostat while the motor was running, I broke the field-circuit at the lng. When we started up again I found the armature injured, and on testing located a punctured coil. As the armature was all right before I touched the field, I cannot make out how my breaking a field circuit could have hurt the armature, even if my boss says I must have, in some way, been the cause of it.*

Answer.—Never open a field-circuit suddenly. If you are familiar at all with dynamos, you must know that current is generated by a wire cutting lines of force. The field-coils of a motor build up an immense field of these lines of force. When the current was first turned into the field-coils, it took possibly 1/10-sec. for the field to build to the full value from the source of 110 V. If by breaking the field-circuit you tended to destroy the field of force in the 1/100 part of a circuit, then the field of force would collapse ten times as fast as they built up. As the rate of cutting determines the voltage the armature would have, each conductor suddenly generates 110x10=1100 volts. Depending on this rate of collapse the momentary voltage might run into several thousands. An action of this kind took place in your case, hence a puncture.

Question.—*What is the reason for Westinghouse rotary converters having copper rings on the pole tips?*

Answer.—To prevent hunting and to help synchronous running. Hunting is due to surges on the line, and may be up or down. These copper

The system is three-phase with balanced load. The distance between the generating-station and the point of distribution is 20 miles. The line consists of three copper wires of No. 4 B. & S. gauge strung 48 in. apart. The pressure at the generating-station is 30,000 volts and the line current 75 amperes. Frequency 60 cycles.

The cross section of No. 4 wire is approximately 41,750 cm. and the radius of the wire approximately 0.1 in. Specific resistance of copper is 10.8.

Then the resistance of one phase of the line is:

$$R = \frac{20 \times 5280 \times 10.8}{41,750} = 27.2 \text{ ohms.}$$

The inductance for 20 miles of one phase of the line is:

$$L = 20 \left( 80.5 + 740 \log \frac{48}{0.1} \right) 10^{-6} = .0416 \text{ Henrys.}$$

The reactance X of the line is:

$$X = 2 \times \pi \times 60 \times .0416 = 15.8 \text{ ohms.}$$

If the ratio of the transformers is:

$$\begin{aligned} \frac{E}{E_1} &= 300 \\ \frac{I}{I_1} &= 15 \end{aligned}$$

then

$$R_1 = \frac{c}{p} R = \frac{15}{300} \times 27.2 = 1.36 \text{ ohms.}$$

$$X_1 = \frac{c}{p} X = \frac{15}{300} \times 15.8 = 0.79 \text{ ohms.}$$

rings, known as dampers, are ordinarily in a light, even, magnetic field, and are practically inert. A surge back into a rotary will change this condition, and either suddenly build up or tear down the field. This results in a big moving field cutting the heavy rings, causing a correspondingly heavy current to be induced in them. This action reacts by opposing the cause of it, by choking down an upward rush, or holding up a falling one. It thereby tends to keep conditions normal.

Question.—*We need more transformers for our outside lines, but on account of the hard times cannot afford to spend much money on them. We have considered buying transformers which will be heavily overloaded during the peak period, but will have a fair load at other times. This will be cheap and the core loss will be reduced. Do you not think this would be a good plan?*

Answer.—Most manufacturers make transformers to give the most efficient output at 75% to 100% load. Running at light loads or heavy overloads would not be economical, and would more than offset running them part of the time at highest efficiency, with a small core loss during light load. But the most objectionable feature would be the danger of injury due to excessive overload. A big repair bill, or a new transformer, would take up any possible savings for a long while. Temperance is the great lesson of life, and applies to buying machinery as well as to human affairs. Don't be pennywise and pound foolish by purchasing something your judgment does not fully sanction.

Question.—*I have four electric bells*

*in series which I cannot get to work. I followed a suggestion in an instruction book, and turned them all into single-stroke bells, except one. When the button is pushed there is a bit of a tinkle sometimes, but no ring. What is probably the cause of my trouble? The circuit tests are O. K.*

Answer.—The trouble is due to faulty adjustment of the screws which regulate the stroke of each bell. All bells must be adjusted for the same movement as the master bell.

**Lamp Testing**

Care should be taken that good contact is secured between all lamp bases and their holders. It is also important to connect the voltmeter leads as near as possible to the lamp terminals. Before closing the standard lamp circuit sufficient resistance should be introduced to avoid all possibility of burning the lamp at a voltage higher than its rated voltage. After this circuit is closed, the voltage should be gradually increased to the standard voltage and the current consumption should then be observed. If the current flowing is then more or less than that specified in the standardization certificate, either the meters are incorrect or the lamp has changed. Reference to the other standardized lamps of the series will indicate which is the case. If these agree well among themselves and the discrepancy still exists, one instrument may be assumed correct and the other corrected so as to bring the wattage up to standard. All lamps to be tested should be mounted with the axes of their filaments perpendicular to the photometer bar.

# General Electric Report

## ENGINEERING SITUATION.

E. W. Rice, Jr., Vice-President of the General Electric Co., reporting to President Coffin on the engineering work of the past year, says:

"During the first part of the last year our engineers were fully occupied in supervising the technical details of our greatly expanded business. Upon the decline in business which followed they have had more time to devote to improvements and economies in design of our apparatus. More attention has also been given to the design of special apparatus intended to meet novel conditions and to the extension of our business along profitable lines.

"The apparatus designed by our engineers for the long-distance transmission of electricity has proved most reliable, economical and satisfactory in operation.

"There has been a continued increase in the capacity of electric generators and transformers.

"Our high-tension switching apparatus has been still further improved, and we have been favored with the most important orders for such installations.

"The details of our steam turbine-generators have been improved, great economy and proved reliability are now assured, and the turbine-generator is now standard for all new important electrical installations where steam is utilized. We are now building turbine units of a capacity of 14,000 kw.; the largest electrical generating units ever produced. The Commonwealth Edison Company, of Chicago, has now in operation in one station nine large turbines capable of generating a total of 103,500 kw.

"Our engineers have devoted considerable attention to the design of a line of turbine-generators for use with exhaust steam. Such steam turbines are so much more efficient than steam engines when operated by low-pressure steam that they can be most usefully employed to supplement steam engines in existing installations. Their use will result in large increases in output without any increase in coal consumption.

"Our single phase alternating current railway equipments have been greatly improved during the past year.

"Our new direct current railway motor, mentioned in my last report, has proved so satisfactory in practical operation that it is rapidly being adopted as the standard type. It

marks an important advance in economy and durability.

"We have extended the range of economical operation of direct current railway apparatus by designing it for use at 1200 volts, about double the existing standard, and have sold a number of such equipments to the Southern Pacific R. R. Co.

"We have sold to the Great Northern R. R. Co. four 100 ton three phase electric locomotives designed to handle all trains traversing the 2½ miles of Cascade tunnel in Washington. This installation will be especially notable as the first instance of the substitution of electricity for steam on a mountain division of one of the Continental railways. The traffic conditions are peculiarly difficult on account of the grades and tunnels. These electric locomotives, because of their increased speed and better control, will practically double the traffic capacity of the present steam locomotives. Electricity for their operation will be supplied from water power hitherto unused.

"A gas-electric car, which fully meets the requirements of Steam Railroad Companies for service on branch lines, has been perfected. The equipment consists of a gasoline engine driving an electric generator, which furnishes current to standard railway motors. The engine and generator are located in the forward end of an especially designed car conveniently divided into passenger and baggage compartments, making a complete self-contained unit.

"We have made many valuable improvements in the design of machinery for electric reduction of metals and in apparatus for various industrial applications.

"We have shipped several large motors of special design of about 10,000-h.p. capacity each for driving rolling mills, and have received orders for additional equipments.

"Important improvements in the design of our lines of wiring devices, rheostats, circuit breakers, switches, instruments, and other small devices, have been made during the year.

"Our new tungsten incandescent lamp, which gives more than double the illumination of the carbon filament for the same expenditure of power, has been further developed and has now become a standard commercial article.

"Several novel types of arc lamps of greatly improved economy have also

been perfected and sold in large quantities."

## SALES SITUATION.

The General Electric Company's annual report upon sales says:

"Among many important orders received during the year are:

"Great Western Power Company, San Francisco, Cal.; three water-wheel generators, 10,000 kw. each, together with the necessary transformers and other electrical apparatus for transmitting current at 100,000 volts from its power house on the Feather River to Oakland, Cal., a distance of about 165 miles.

"The Central Colorado Power Company, Colorado Springs, Colo.; four 5000-kw. generators and other electrical apparatus for water power development at Glenwood Springs on the Grand River, the electrical energy to be transmitted throughout the central portion of the State for mining, general power, lighting and railway service.

"The Detroit River Tunnel Company, a subsidiary of the Michigan Central Railway Company; apparatus for equipment of the Detroit Tunnel under the St. Clair River. The contract includes several 1000-kw. motor-generator sets with accessories and six 100-ton locomotives, each equipped with four 250-h.p. motors.

"The Great Northern Railway, for electrification of the Cascade Tunnel; water-wheel generators and 100-ton locomotives, each equipped with four 250-h.p. alternating-current motors, giving a continuous output of 1000-h.p. per locomotive.

"The Southern Pacific Railroad Company, for electrification of its suburban lines in Oakland and Alameda, Cal.; forty-four four-motor equipments with Sprague-General Electric control. The motors are 125 h.p. each.

"The Hudson Tunnels Company; the turbine generators, rotary converters, motors and controlling apparatus for complete electrical equipment of its system of tunnels under the Hudson River connecting New Jersey and Manhattan. A portion of this system was put into successful operation on February 25, 1908, and regular service is now maintained between 19 Street (6th Avenue), New York City, and Hoboken, N. J.

"The West Jersey & Sea Shore R.R. Co., a branch line of the Pennsylvania Railway running from Camden to Atlantic City, mentioned in last year's re-

port, has maintained its record of satisfactory operation and orders for additional equipment have been received during the past year to provide for the increased traffic.

"The New York Central and Hudson R. R.R. Co. is now operating in its New York City Terminal 35 electric locomotives of our manufacture, each equipped with four 550-h.p. direct-current motors. Twelve additional locomotives have recently been ordered, making a total of 47 locomotives purchased from us by this company.

"The use of electrical apparatus for industrial purposes is extending rapidly and large purchases of our apparatus have been made during the year for completely equipping mills with turbine and engine-driven generators for lighting and power, and with motors of standard and special design for driving machinery of every description.

"Orders for supplies, such as meters, transformers, arc lamps, wiring devices, electric heating devices, repair parts of electrical apparatus, etc.,

show an increase over last year. Our list of supplies comprises upward of 50,000 items, separately catalogued and priced. In addition to the large stock of finished product carried at the several points of manufacture, we maintain 14 warehouses in various cities from which shipments to the value of over \$6,000,000 were made during the year.

*"1200-Volt Direct Current System.*

"To meet the requirements of inter-urban railways where a potential higher than 600 volts is desirable and the conditions are unfavorable to the adoption of the single-phase alternating-current system, we have developed a high-voltage direct-current railway system to operate at 1200 volts. Two roads have been operating under this system for several months with entire success. Equipment for several additional roads of this character is in process of installation.

*"The Curtis Steam Turbine.*

"The Curtis steam turbine continues to give excellent service, and the confidence of users is evidenced by numerous additional orders for exist-

ing installations. The total number of Curtis turbines shipped to date is 960, having a total capacity of 1,086,000 h.p. Orders were received during the year for turbines aggregating 380,000 h.p. We now have in process of manufacture for the Commonwealth Edison Company of Chicago and the New York Edison Company a number of turbine generators of 14,000-kw. capacity each, which will be the largest steam-driven electrical units ever produced.

*"Incandescent Lamps.*

"The consumption of carbon filament lamps has steadily increased during the year, and with our enlarged capacity we are prepared to take care of the demand. In addition, we have received large orders for different types of high efficiency metal filament lamps, first consideration being given to such sizes and types as will aid central lighting stations in providing for the requirements of their customers and the extension of their business."

The actual condition of the Company and its allied companies and their operations is shown in the following balance sheets:

CONSOLIDATED BALANCE SHEET OF JANUARY 31, 1908.

ASSETS.		LIABILITIES	
Patents, Franchises and Good-will.....	\$ 1 00	5 % Gold Coupon Debentures of 1892.....	55,000 00
Cash.....	12,250,720 92	3 1/2 % " " " of 1902.....	2,047,000 00
Stocks and Bonds.....	\$18,000,089 55	5 % " " " of 1907.....	12,872,750 00
Real Estate (other than factory Plants).....	541,900 50	Accrued Interest on Debentures.....	108,791 67
Notes and Accounts Receivable.....	29,857,726 84	Accounts Payable.....	1,759,517 47
Work in Progress.....	1,276,294 22	Unclaimed Dividends.....	1,469 86
	\$49,676,011 41		\$16,844,529 00
Merchandise Inventories:		Capital Stock Issued.....	65,167,400 00
At Factories.....	\$18,339,652 06	Surplus.....	16,513,836 14
At General and Local Offices.....	2,422,678 59		\$98,525,765 14
Consignments.....	234,725 16		
	20,997,055 81		
Factory Plants (including all lands, buildings and machinery).....	\$12,900,000 00		
Copper Mining Interest.....	2,701,976 00		
	15,601,976 00		
	\$98,525,765 14		

CONSOLIDATED PROFIT AND LOSS ACCOUNT OF JANUARY 31, 1908

EXPENSES.		EARNINGS.	
Cost of Sales (including depreciation of Plants \$3,745,989.06).....	\$65,536,305 06	Sales.....	\$70,977,168 46
Interest on Debentures.....	362,029 63	Royalties, Dividends, Bond Interest, readjustment Stocks and Bonds account, and Sundry Profits..	\$1,010,961 63
Profit for the current year.....	6,586,653 37	Interest and Discount.....	457,079 04
	\$72,484,988 06	Profit on Sales of Stocks and Bonds.....	1,498,040 67
Dividends paid in Cash.....	\$5,183,614 00		9,778 93
Surplus at January 31, 1908, carried forward to next year.....	16,513,836 14		\$72,484,988 06
	\$21,697,450 14	Surplus brought over from last year.....	\$15,110,796 77
		Profit for the year ending January 31, 1908.....	6,586,653 37
			\$21,697,450 14

CONSOLIDATED BALANCE SHEET OF AFFILIATED COMPANIES, JANUARY 31, 1908.

ASSETS.		LIABILITIES.	
Property Accounts.....	\$4,523,284 93	Capital Stocks.....	\$4,015,000 00
Patents, Franchises and Good-will.....	3 00	Bonds.....	535,000 00
Current Assets		Current Liabilities.....	223,382 42
Merchandise, Material and Supplies.....	\$2,560,100 01	General Electric Company.....	2,860,935 66
Work in Progress.....	114,389 20	Surplus	
Notes and Accounts Receivable.....	1,642,752 98	As at January 31, 1907.....	\$1,309,982 23
Stocks and Bonds.....	7,426 70	Add profits for year.....	\$365,438 94
Cash.....	301,782 43	Less dividends.....	160,000 00
	4,626,451 32		205,438 94
Discounted Paper.....	246 48	Endorsements.....	1,515,421 17
	\$9,149,985 73		246 48
			\$9,149,985 73

HENRY W. DARLING, Treasurer.  
EDWARD CLARK, General Auditor.

### New Breakdown Rate for New York

As a result of the investigation conducted by Commissioner Milo R. Maltbie and according to the recommendations made by him in a preliminary report to the Public Service Commission the New York Edison Company has modified its rates for "break-down service" so that the charge shall be based upon the maximum demand of the consumer and not upon the full capacity of his installation. This agreement is to last for one year, during which time it is also agreed the company will place recording devices upon every breakdown connection and take the records of the current furnished under the supervision of the Commission, for the purpose of determining a fair charge for the service.

Commissioner Maltbie finds that a satisfactory decision of the rate question cannot be made until such records are taken, and he recommends that the work be carried out and that the electrical engineer of the Commission be instructed to supervise it. The fact that no such records have been taken in the past makes it impossible to arrive at a just and adequate charge for this kind of service.

The report points out that "break-down service" includes three kinds of service:

No. 1.—The service supplied by the company to a private consumer having his own plant, when that plant breaks down and is unable to produce the current required by the consumer.

No. 2.—Auxiliary service supplied to private consumers using current at nights, on Sundays and holidays, and during periods when a small amount of current is used as compared with the total installations.

No. 3.—Peak load service—additional current furnished to private consumers at that hour of the day when the peak load or the maximum demand from all consumers occurs.

Commissioner Maltbie says that the term "break-down service" does not include the supply of current for a segregated circuit in any building, and that where such segregated circuits exist, even though there may be a private electric plant upon the premises, all of the electric light companies have stated that they are willing to supply current at the usual rates.

As to the first class of "break-down service," the report says it is probable, in view of the comparative infrequency of complete disability, "that the actual demands made upon the supply company would be very few and would not involve great expense, either in the way of fixed charges upon the

duplicate plant kept ready for use, or in the way of operating charges for units revolving slowly."

In order to furnish such a service the supply company must provide merely the distribution system and the service connections for the maximum load to be demanded at any one time, and such apparatus in the generating and substations as would be equivalent to the private plants disabled at any one time. It is not necessary to duplicate the total installations of the private plants, but merely such a portion as would be at any one time out of use.

To supply the second class of consumers, says the report, the supply company would need to provide the necessary service connections and distribution lines for each user, "but as current would be demanded when the stations of the company would otherwise not be operated at their maximum capacity, it would not be necessary to provide station equipment specifically for this service, but it might be necessary to keep certain units revolving slowly, but in this respect the service would not differ from the ordinary service, where there must be constant readiness to serve somewhat in excess of the demand at that moment."

"The third kind of service," the report continues, "is the most expensive of all, for if any restriction were placed on the amount of current consumed or the time of its use, breakdown consumers could easily so plan their equipment that they would have sufficient capacity to supply all the current required, except during the peak hours of the day. When the peak load began to come on, the breakdown user could take sufficient current from the supply company to handle this peak, breaking the connection when the peak hour passed and the consumption again became normal.

"Inasmuch as the peak period for the breakdown consumer is apt to be the peak period for the supply company this would mean that the company would be called upon for a considerable amount of current during the short period when the demands of the ordinary consumers are at their height. Thus the supply company would be obliged to maintain a considerable plant during the whole day in order to supply the breakdown consumer during one or two hours and to carry the surface plant throughout the year in order to handle the winter maximum due to the short period of daylight and cloudy weather."

Commissioner Maltbie finds that the public supply companies, inasmuch as they have franchises for the use of the streets, are under obligations to pro-

vide breakdown service under ordinary circumstances, assuming that the rate is fair and that a reasonable profit is allowed. Prior to the passage of the law of 1905, fixing the maximum price of current in Manhattan at ten cents per kilowatt hour, the New York Edison Company supplied breakdown service to every applicant. Since that time, and until the Public Service Commission was created, the company refused to supply breakdown service except to those who already had contracts. It was this refusal which brought the matter before the Public Service Commission and resulted in the investigation by Commissioner Maltbie.

The Edison Company first offered to supply this breakdown service for the maximum charge or guarantee of \$30.00 per kilowatt of installation. "As a result," says Commissioner Maltbie, "the individual who had lamps, motors and apparatus of a total capacity of 100 kw. would be obliged to guarantee an annual payment of \$3000.00, no matter what amount of current he consumed; no matter whether he used only 20 or 30 kw. at any one time."

Commissioner Maltbie concludes from this that a charge based upon installation and not upon the maximum demand would be generally unjust. After several conferences the representatives of the Edison Company agreed to change this charge so as to base it on the maximum demand instead of on the total installation of private consumers. The breakdown rate as now agreed to, therefore, will be a service charge of \$30.00, including the supply of electric light at the best rate of the class for each kilowatt of maximum demand, for which the consumer may make written request to the company, and which maximum demand is to be the basis of a year's contract. The company puts this rate into effect for one year, with the privilege of withdrawing it at the end of that time if it is found to be unsatisfactory.

### American Circular Loom Co.

The Chelsea plant of the American Circular Loom Co. was entirely destroyed by the recent conflagration which devastated Chelsea. The Company opened offices the next morning in the International Trust Building, Boston, and began the work of assembling machinery for the manufacture of circular loom, which was the only product manufactured at the Chelsea plant.

The electroduct factory operated by the American Circular Loom Co., at Kenilworth, N. J., is in full operation, and the new metal molding plant, lo-

cated also at Kenilworth, is now fully completed, including a large electro-galvanizing plant.

A new factory for the manufacture of circular loom has been secured in North Cambridge, Mass., and in a very short while circular loom will be shipped from the new plant. The most serious aspect of the fire was the very severe loss suffered by the employees of the company, nearly all of whom lost house, home and all they possessed. One fatality resulted.

#### The Copper Hand-Book

Volume VII of the new edition of the Copper Handbook has just been issued by the author, Horace J. Stevens, of Houghton, Mich. The book has 1228 pages, octavo, being materially larger than before. The author apologizes for his inability to revise the book throughout, explaining that fire, sickness and loss of five months' time prevented, but the new volume contains about 180,000 words of new matter.

The new edition of the Copper Handbook contains 25 chapters, an increase of nine, treating of copper under the headings of history, geology, chemistry, mineralogy, mining, milling, concentrating, hydrometallurgy, pyrometallurgy, electrometallurgy, alloys, brands, grades, uses, substitutes, terminology, geography, copper deposits, copper mines and statistics. Price \$5.00.

#### Large Railway Motor Contracts to General Electric Co.

Contracts made by the Chicago Railways Co. this year and by the Chicago City Railway Co. two years ago with the General Electric Co. for quadruple 40 h.p. equipment involved a cut of more than 20 per cent. by the industrial concern under regular prices quoted for such equipment. The former has ordered between 300 and 400 cars and the latter has equipped about 700. There will be 800 additional cars on the Chicago Railways lines within three years, bringing the total new equipment of both companies up to about 2000 cars.

The two companies and the city saved about \$1,000,000 by the bargains at which this equipment has been secured and contracted for.

#### The General Electric Tungsten Lamp

The General Electric Company has obtained very satisfactory results with the tungsten lamp. They have shipped over 75,000 to all parts of the country and the breakage in shipment is below one and one-half per cent. They state that they are issuing a new bulle-

tin covering tungsten lamps, both series and multiple, and have a large production, good stocks and are in position to make prompt shipments, particularly of the 100-watt and all types of tungsten lamps which they have standardized.

#### Westinghouse Turbines for Manila and Japan

No less than ten machines, aggregating 25,000 h.p., are included in a large shipment of Westinghouse turbo-electric power equipment from East Pittsburg to the Far East. Most of these machines will go to Japan for the equipment of railway, lighting and manufacturing plants.

One of the first machines to be put in service will be a 1500 kw. turbine unit for Manila, to be installed in a station with four other machines of like construction put in service several years ago. This railway system was engineered and constructed by the American engineering firm of J. G. White & Co.

Hardly second in importance is the large turbine station of the Osaka Electric Company, Osaka, Japan, now building. This will be one of the largest power stations in Japanese territory and will contain for the present 15,000 kw. in five units. Three of these machines are now being shipped from East Pittsburg. The remainder will follow as fast as they can be built and tested. The Osaka installation is under direct charge of Messrs. Takata & Co., of New York and Tokyo.

In the strictly manufacturing field, there are two installations in process of erection, for the Imperial Steel Works of the Japanese Government and the shipyards of the Hakkaido Tanko Steamship Co. Two 500 kw. Westinghouse-Parsons turbo units will comprise an initial installation in each of these plants.

#### Low Lighting Rates For Lafayette, Ind.

The city of LaFayette, Ind., has just closed a contract with the Merchants' Electric Light Association for lighting the streets, alleys and public buildings for a period of 10 years.

For the last 20 years the city has been paying \$66 per lamp year, for 2200 hr. of lighting, with 6.6-ampere direct-current open arc lamps.

Under the new contract, which goes into effect Sept. 1, 1908, the company will furnish and light 300 metallic-flame arc lamps 2500 hr. for \$37.98 per lamp per year, and extra lighting at one cent per lamp per hour. This will amount to a saving of about \$100,000 to the city in 10 years.

After complete tests made at the photometric laboratories of Purdue University, the Westinghouse four-ampere metallic-flame arc lamp has been selected by the Board of Works.

The engineering work, preparation of specifications and contracts has been done by J. Walter Esterline, consulting engineer.

#### Williamsburg Bridge Cables

Dossert & Company, 242 West 41st Street, New York, have designed a special extension fitting for their solderless cable taps, which are used as equalizers on the feeder cables supplying power to Brooklyn Rapid Transit trains which are to run over the new loop connecting the Williamsburg and Brooklyn Bridges. The cables range in size from 2,500,000 cm. to 500,000 cm. The work is under direction of Latey & Slater, consulting engineers. The Gore Engineering & Contracting Company have placed orders for 244 sets of these large double taps, 164 regular taps and a number of two-way Dossert joints, including 134 connecting aluminum to copper.

#### PERSONAL

Mr. Wynn Meredith has become a partner in the firm of Sanderson & Porter and will have charge of the Western office which they have opened in the Union Trust Building, San Francisco.

After a technical training at the University of Illinois, Mr. Meredith, in 1888, became engaged in the construction and operation of lighting and railway properties. He was actively connected with the engineering and operation of the electrical plant of the World's Fair at Chicago, in 1893, and the California Fair, in 1894, subsequently becoming associated with Messrs. Hasson & Hunt, and later a member of the firm of Hunt, Dillman, Meredith & Allen, San Francisco, Cal.

During fifteen years' residence in California Mr. Meredith has been engaged in general engineering work and prominently identified with many of the important hydro-electric and transmission developments on the Pacific Coast, in the United States and Canada.

Announcement is made of the appointment of Professor C. F. Harding as head of the school of electrical engineering of Purdue University. Professor Harding is a graduate of Worcester Polytechnic and has had a broad practical training as an engineering teacher. His special training has been along the line of high tension railway work, and he was electrical engineer for the first railway of that character in New England. He has

(Continued on page 12.)



# THE ELECTRICAL AGE

Volume XXXIX. Number 6.  
\$1.00 a year; 15 cents a copy

New York, July, 1908

The Electrical Age Co.  
New York and London

ESTABLISHED 1883

Published monthly by The Electrical Age Co., 45 E. 42d Street, New York.

J. H. SMITH, Pres. C. A. HOPE, Sec. and Treas.

JOHN HAYS SMITH, Editor.

Telephone No. 6438 38th. Private branch exchange connecting all departments.

Cable Address—Revolvable, New York.

SUBSCRIPTION RATES

United States and Mexico, \$1.00; Canada, \$1.50. To Other Countries, \$2.50

NOTICE TO ADVERTISERS

Insertion of new advertisements or changes of copy cannot be guaranteed for the following issue if received later than the 15th of each month.

LONDON OFFICES

Business and Editorial Departments, 33 Bedford Street  
Strand, W. C.

London Telephone, Post Office, 3807 Central. Private branch exchange. London Cable  
Address—Revolvable, London.

All remittances to London Office should be crossed London and County Banking Company.

BRANCH OFFICES AND AGENCIES

Subscriptions may be sent to the following branch offices or agencies, where they will receive the same careful attention as at the home office in New York:

124, Queen St., Melbourne  
359, George St., Sydney  
61, Main St., Yokohama  
23, Esplanada Rd., Bombay

33, Loop St., Cape Town  
Unter den Linden, 5, Berlin  
Nevsky Prospect, St. Petersburg  
31, bis rue de Fauburg Montmartre, Paris

General Agents for United States and Canada: The American News Company

## Returning Prosperity

The electrical industry is still largely of a sort to feel the sensitive trend of the money market in spite of the fact that its manufactured product is a staple necessity, the demand for which should be as steady as that for oil, soap, sugar or other articles needed in daily life. The reason lies in the fact that the total electrical product is of two distinct kinds: First, the manufacture of supplies and apparatus to replace what is used up or worn out—and this business increases in poor times; and second, the manufacture of apparatus for new electrical projects which require to be financed. In a season of hard money the latter class of business becomes very light. It shrunk in the late panic to almost nil, falling to a point well below that reached in the depression of 1903-4.

In a time of depressed trade, the supply business actually increases, owing to the fact that motors and other apparatus which in ordinary times would be scrapped are made to do duty even at the cost of excessive repairing. Were it not for the steadiness of this kind of business it would be well-nigh impossible for the large manufacturers to make a profit on their business as a whole. These facts were abundantly demonstrated in 1904, which was the first severe depression since the electrical industry had grown to a large volume.

Conditions are not different at the present time, except that the recovery promises to be more rapid than usual. The large operating companies are raising money under bond issues and coming into the market for big apparatus. The demand for estimates on new work is now practically as heavy as ever. Collections are more satisfactory than in any previous depression. There are abundant indications that the present depression in the trade has turned and that business is rapidly working to a normal level. This is the general opinion of well-in-

formed men in the trade. In a very recent interview President Walter H. Whiteside, of the Allis-Chalmers Co., gave forth a statement which, while it applies to his company in particular, is in a measure true of the entire industry. He said:

"There is a marked improvement in general business. Within the last 90 days the bookings of machinery orders have increased from 30 per cent. to 50 per cent. of normal. The business for June to date indicates that at least 65 per cent. of normal will be reached. New inquiries received are constantly increasing in number and volume. They are of a much more substantial character than at any time since the depression began. Their general tone denoted extensive plans in contemplation and for early development; the question of prompt shipment being already regarded an important consideration.

"The immediate requirements for a larger volume of new machinery for necessary extensions and improvements to existing plants are greater than for four years. This for the reason that with many operating companies purchases which under ordinary circumstances would have been made a year or eighteen months ago, were put off, due to the monetary and other conditions, until to-day the factor of safety in these plants is becoming a serious matter and new equipment must be added.

"Unlike previous depressions, following which collections for comparatively long periods continued very unsatisfactory, there was a substantial improvement within a short time after the recent flurry, and at the present time collections are exceptionally good.

"While some difficulty may still be experienced in the way of financing entirely new undertakings, yet the financial condition of the relatively small buyer is on a sound basis and credits are about normal. In fact, the

improvement in new orders placed is from the smaller class of purchasers, who are, commercially, an important factor. Of course, this class of business is widely diffused, but in the aggregate it is greatly stimulating improved trade conditions.

"The business outlook is distinctly encouraging."

## Westinghouse Readjustment is a Success

At the meeting of the readjustment committee of the Westinghouse Electric Mfg. Co., June 26th, it was decided to give the merchandise creditors' committee and the stockholders' committee until September 1st to put the finishing touches on their work. The readjustment committee accepts the plan of the other committees but will allow a postponement in terminating the receivership until September 1st in order to thoroughly finish the work which was hastily done in the last few days before the conferences which resulted in the acceptance of the plan of the merchandise creditors' committee. George Westinghouse is to be congratulated for the splendid fight he has made. Much credit must also be extended to Jos. W. Marsh, chairman of the creditors' committee, L. A. Osborne, second vice-president of the company, and C. P. Humphrey, of the employees' committee for successfully getting the readjustment plan to a solid basis.

While no public statement as to the amount of subscriptions has been made, it can be stated that it falls very little short of the stipulated \$10,000,000 which the merchandise creditors set out to raise on April 2d, after the Jarvie readjustment committee had wrestled with the problem for five months without evolving a plan which promised success.

The fruition of the present work will enable the company to start business with quick assets approximating

\$32,000,000, of which \$12,000,000 represents actual cash. The company will also have about 1500 new stockholders, many of whom are influential in the trade.

#### The Transformer Station

The layout of switching devices in transformer stations has assumed an importance in late years of hardly less degree than that of the generating station itself. In main essentials the problems which develop are not different from those which confront the engineer in designing the switching arrangements in the main power station. Failure to recognize this truth clearly, coupled with failure to handle the current in the same complete manner, has led to many costly lessons. Experience has shown that it is wisest, if not less costly, to take all precautions against the development of arcs, their spreading to apparatus not directly involved, and the provision of means for automatically cutting out damaged conductors and apparatus. Every effort is now subordinated to the end of maintaining continuous operation.

In a paper read before the recent National Electric Light Convention at Chicago, and reprinted in full at another page, Mr. Stephen Q. Hayes discusses these matters in some detail and dwells particularly upon the features which provide automatic protection. Mr. Hayes points out the difficulty of preventing an overload or short circuit occurring on one line from tripping all of the breakers on the other incoming lines, and indicates the proper selection of relays to avoid this trouble.

#### The Copper Situation

When Americans were buying copper last year around 25 cents Europe was keeping out of the American market by drawing upon her reserve stocks. Now Europe is buying very largely in the American market. The supply, however, is going largely into current production. There is nowhere a visible large stock of copper.

For the past four months the price of copper has been hovering between 12½ and 13 cents, and while inquiries have increased very much, the buying is still only in moderate quantities. The Westinghouse and General Electric Companies are reported as buying only for present needs. The Allis-Chalmers Company is known to have placed a very large order, sufficient, it is said, to provide for their entire output during the coming year.

The feeling in the trade is that we have passed the low point of the depression. In support of this opinion there is, first, an entire absence of cop-

per stock with producers and consumers; second, a normal state of business confidence based upon the clearing political situation; third, the actual demand for copper is increasing; fourth, the large operating companies are getting bond issues, the proceeds of which will later be used in plant extension.

Daniel Guggenheim, president of the American Smelting and Refining Co., is reported as saying that it is now possible to sell all of their copper at 13 cents a pound, whereas four months ago it was hard to make sales at 12½ cents.

#### The N. E. L. A. Gas Engine Report

The report of the N. E. L. A. Committee on gas engines is voluminous. It covers 170 pages and represents a good deal of painstaking work. Exactly 13 pages present the experience of users of gas engines in 33 different plants. From the list of installations furnished by the manufacturers for their investigation the committee has eliminated from consideration "all units of less than 300 h.p."

While the word "unit" apparently refers to a single engine unit, still a reference to the tables proves this not to be the case. What the committee means is that it has eliminated from consideration every gas-engine plant having a capacity of less than 300 h.p. Some of the gas engines listed in the tables are under 100 h.p.

The remainder of this bulky report is filled with a description of manufacturers' descriptions of their products—a most useful piece of work since this information is brought together under the compass of a single cover.

Of the 33 gas-engine installations, 18 run on natural gas and 12 on producer gas, though it is not recorded what type of producer is used, which is a highly important bit of information. It were also a desirable thing if the committee had indicated which engines were operated in the central station field. The total horse power installed as reported by the manufacturers is 183,113 h.p., with 55,225 h.p. generated by producer gas, of which 35,625 is from bituminous coals and 12,250 from wood and lignite. This fact is surprising in view of the generally reported unsatisfactory action of the bituminous producer. Of the 33 plants reporting, 19 contain Westinghouse engines, five have Crossley engines, four Snow engines and three are of Koerting manufacture. Definite replies as to the maximum length of time the gas engine can be kept in operation run anywhere from a week to six months.

Very few report trouble with igniters; practically none are bothered with back-firing or pre-ignition. The consensus of opinion regarding reliability is that it is as good as the steam engine. Fourteen of them report parallel operation as satisfactory, while only one reply is unfavorable. The committee may be congratulated in confirming what has been very generally understood—that the gas engine is a satisfactory piece of mechanism. It is to be regretted that it did not obtain "results" in its investigation of the 31 producer plants which it enumerates.

The report presents an impressive list of Westinghouse installations of 300 h.p. or over, including 16 central station plants. There are about 118,000 h.p. of gas engines built and on order by the Allis-Chalmers Co., which is a splendid showing, considering that this company entered the gas engine field long after the Snow Steam Pump Works and the Westinghouse Company. The total of Snow Gas Engines built and under construction is 135,510 h.p.

The real question which should have engaged the attention of this committee is the producer end of gas power generation. It is to be hoped that next year the committee will have enough satisfactory data on this subject to remove the current impression that the gas producer is uncertain in its action, and as yet largely in the experimental stage in this country in its operation on bituminous coal. It would be advisable to collect some data on the initial cost and maintenance of stations of various size. We are of the impression that in spite of the halving of the full bill by the gas engine, that the maintenance of a gas-engine-producer outfit is nearly twice as much as a steam plant, that the initial cost of a small plant is about 50 per cent. above that of a steam plant, and that with any size of station the operating force must be larger.

#### Motors for Steel Mills

For a long time motors installed in steel mills were used only for driving pumps, compressors, cranes and conveying apparatus. No one was able to guarantee successful apparatus if motors were applied to the main operation of rolling steel. The rolling mill offered about as severe conditions to overcome as one could find, the load varying from a few hundred horse power to 20,000-30,000 at a maximum on the blooming-mill roll. The blooming roll takes a red-hot ingot about two feet by two feet by six feet, and passes it through the rolls back and forth, reducing it to the proper size for sec-

ondary rolling into building beams, rails or other finished shapes.

So severe are the loads, jumping from a few horse power to hundreds or thousands in an instant, and going off equally sudden, that direct rolling by motors has been one of the last applications in displacing the steam engine. Engines for this work had been uneconomical, heavy, costly and subject to continual repair. They were clumsy for the operator to handle, and in nearly every way undesirable.

The chief reason, however, for wishing to displace the steam engine was that after a breakdown of the engine it might require anywhere from a half-hour to twenty-four or more to effect the repair, whereas, in the case of a motor, it is the work of only a few minutes to slip in the spare armature or field coil, or even to replace the entire motor. The importance of this is realized when one reflects that one hour's shut-down from continual rolling at the Edgar Thompson rail mills means a loss of something like over \$1,000.

Good rewards were offered manufacturers if they could step into the rolling-mill field, and, finally, they have done so. Motors up to 10,000 h.p. have been installed, and very probably the 25,000-h.p. engine now being built by the Allis-Chalmers Company will be duplicated by them with a motor of equivalent or greater rating when the time comes.

In the solution of this problem, the natural first step was to add a heavy fly-wheel to ease off sudden changes in load. A second step was to use a very liberal rating for the normal rating of the motor, while a third was to provide for excessive overload capac-

ity amounting usually to 300 per cent. for a half-hour. Rapid reversing is another point which had to be looked out for, and, therefore, armatures of small diameter had to be designed to reduce the so-called centrifugal effect. This meant a minimum total fly-wheel effect.

Both alternating and direct-current motors have been used when direct current they have been compound wound on the basis of 15 per cent. compound, 85 per cent. shunt. When of the alternating-current type, the rotors have been of the wound construction, so that external resistance might be inserted for large starting torque, or speed control, or both.

The commonly used voltages are 230 when direct-current equipment is used, and 220 or 440 for alternating current. A frequency of 25 cycles only has been used on account of the slow speeds to be dealt with on the rolling-mill shafts.

Smaller motors are built of the enclosed type, while from about 150 h.p. open motors are used. In the latter case the motors and controlling apparatus (except for the drum-type controller used by the operator) are installed in a room of brick or sheet metal with the shaft extending through the wall. Frequently, however, the cover is only a large box which may readily be removed from the motor. Mill work is a special field, and each problem has to be considered separately on its own merits.

#### Testing Lamps by Substitution

In making photometric tests of incandescent lamps two methods are available: The lamp to be tested may

be compared either directly with a standard lamp, or with one of a series of lamps which have been thus standardized. The direct comparison method has the disadvantage of burning the standard lamp during the entire test and thus shortening its period of usefulness. For this reason it is not recommended for most purposes, and the substitution method is preferred. This method has the advantage of automatically illuminating photometric and instrumental errors, besides those due to the personal equation.

In testing lamps by this method care should be taken that good contact is secured between the lamp base and its holder. It is also important to connect the voltmeter leads as near as possible to the lamp terminals. Before closing the standard lamp circuit, care should be taken to avoid the possibility of burning the lamp at a higher voltage than that at which it is rated. When the circuit is closed the voltage upon the standard lamp should be gradually increased until its standardization voltage is reached. The current flowing through the lamp should then be determined. If under these conditions the current through the lamp is more or less than that specified in the standardization certificate, then either the meters are in error or the standard lamp has changed. Reference to the other lamps of the standard series will then indicate which is the case. If the standard lamps are in good agreement among themselves, and the discrepancy still exists, one of the meters may be assumed correct and a correction applied to the other sufficient to bring the wattage up to the standard.

# Some Points to be Considered in the Purchase of Steam Turbines

JOHN HAYS SMITH

**P**ROSPECTIVE buyers of steam turbines are usually at a loss to know just what features of the steam turbine merit consideration. The representative of an impulse type is liable to point out the defects of the reaction turbine, but remain eloquently silent on those features of his own make which he desires to remain undiscussed. The relationship is reversed if a reaction man has the field to himself. Some of the features of turbines which generally come up in turbine negotiations are given here in order that our readers may be better prepared to receive the turbine salesman.

## TYPES.

Impulse turbines are in almost every respect similar to Pelton water-wheels in principle. Pelton water-wheels are used only under high heads and great velocities. The buckets of impulse steam turbines operate likewise at high velocity by reason of the steam speed. As the steam passes from the boiler to the turbine, its speed is relatively low. Just before reaching the buckets it ordinarily passes through expanding nozzles, which allow its pressure to drop and volume to increase. Evidently it will have to discharge at a higher rate than it entered the expanding nozzle in order to make way for the high pressure steam following. It is in this way that the potential energy of the steam (due to its pressure) is changed into kinetic energy (energy of motion), causing the steam to impinge on the buckets at enormous velocities.

The reaction turbine is similar to the well-known Samson or the Esher-Weiss water-wheel. The former are well known when low heads are to be used. The latter type of wheel is used for medium heads and is installed at the original Niagara power plant. In the reaction type of steam turbine, the steam enters the turbine at boiler pressure and expands through stages down to atmospheric pressure, or into a condenser.

Both types have equally enthusiastic supporters, and for straight steam economy there is practically no choice, where conditions remain normal, manufacturers' claims to the contrary notwithstanding.

The best-known impulse type is the Curtis machine, manufactured by the General Electric Co. Up to 300 kw. it is of the horizontal type, but of

vertical forms in sizes from that point up. If necessary, it can be built in larger sizes for the horizontal position.

The Westinghouse Company first made the reaction turbine popular in the United States. They have always made them of the horizontal type only. This same type of turbine is manufactured by the Allis-Chalmers Company, which has added a number of features of design of its own development.

## SHAFT SPEEDS.

In considering the relative merits of the two types of turbines, it is found that the impulse type has the slower shaft speed, in some cases by one-half. This, too, in spite of using higher steam velocities. The shaft speed is slower because the buckets are mounted upon the rim of large diameter disks, giving high peripheral velocities (up to five miles per minute), but quite slow for turbine shaft speed. In the reaction type the blades are mounted upon an enlarged section of the shaft itself, giving a more compact size but a higher shaft speed.

The question naturally arises, why not use large diameters on the reaction type and obtain slow speeds? The answer is, because the steam leakage (principally) would be increased. In this type the steam is expanding as it traverses the buckets, and consequently has motion in every direction. If the diameters were increased, it would mean increased leakage area between the stationary and the revolving part. In the impulse type, on the contrary, the steam is practically all expanded in the nozzles before it gets to the interior, and therefore has motion in one direction only. Consequently, an increase of clearance has less effect.

This fact became evident only after much experimenting.

In both types of turbine, clearance between moving and stationary buckets is of the same relative importance, while in the impulse type the radial clearance is not a factor in the economy of the machine. The radial clearance is of importance in the reaction type.

## WARPING.

It was warping in the outer shell which led to early troubles in the Parsons type. The first big improvement of the Allis-Chalmers Company was to place a channel

iron on the ends of the blades. While warping might cause the outer shell to wear into this iron; at least, the operation of the turbine was not interfered with. The Westinghouse Company later adopted a method of strengthening its blades by drilling a hole close to the end and threading a comma-shaped wire through it. This peculiar cross-section was selected so that the edge might be turned down between the blades to insure proper spacing and non-interference with the flow of steam.

## BALANCING.

The impulse type needs no balancing for end thrust, as the steam enters each bucket and leaves it at approximately the same angle.

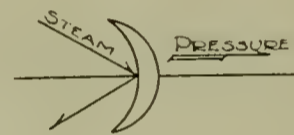

CURTIS

Consequently the pressure is always in the direction of rotation. In the Parsons type two forces appear: one in the direction of rotation and the other parallel to the shaft, and added to this we have unbalanced steam pressure in the rotor. To offset this, pistons are mounted at the emission

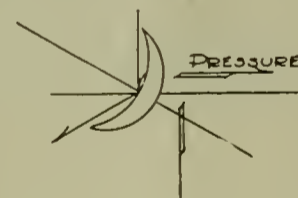

PARSONS

end of the shaft of sufficient area to counterbalance the end thrust. Live high pressure steam is admitted to the chamber containing them to furnish the counterbalancing force. The Westinghouse Company is also building large sizes of the double-flow type, which is self-balancing.

## SIZE OF BUCKETS.

In the Curtis turbine all buckets are of a uniform size and of about three times the cross-section of the blading of the Parsons turbine. The Parsons' blading increases in size as the steam passes toward the low-pressure end. The theoretically perfect shape of a Parsons rotor would be a

cone. Commercial and mechanical reasons, however, limit the changes in blading to stages. There has been some discussion as to the methods of fastening in the buckets and blades. But after much experimenting on the part of the manufacturers, methods have changed but little. With the continued use of the turbine it can be safely said that this point has but little real weight as a cause of trouble, or a hindrance in case of repair. Curtis buckets have a ring on the outside which serves as a guide to keep the steam from spilling from the buckets, and to hold them together. In the use of the words "bucket" and "blading," both terms are employed to perform the same function in the turbine, but impulse type machines have the receptacle or cup called a "bucket," while in the reaction machine, on account of the smaller size in cross-section, the word "blade" is used.

GOVERNORS.

In the Parsons type an improved throttling governor is used. This reduces the volume of steam admitted to the turbine with change of load. It is evident that while steam is admitted to the high-pressure end of the turbine for ordinary work, there is no reason to prevent high-pressure steam from being turned directly into the second stage. This is a feature which the makers of the Parsons turbine offer with their machine, and, by it, enormous overloads can be carried, as the second stage blading has a much larger surface than the first stage. Of course the efficiency of the turbine is dis-

turbed while it is operating this way, but as an emergency feature it is very valuable.

The Curtis turbine is like a gas engine in that it has a definite load limit. This may be 25 per cent. or 50 per cent. more than the normal rating, according to the requirements of the buyer and his willingness to pay for it. Ordinarily the overload capacity is based on the overload capacity of the standard generator, which is 25 per cent. for two hours. A given amount of blading with a definite volume of steam at a predetermined pressure, vacuum and superheat can give but one maximum horse power. If this is called five-fourths of normal load, then 25 per cent. overload is obtainable. If a greater bucket surface is used and this is six-fourths of a normal rating, then the turbine has 50 per cent. overload capacity.

With a given maximum horse power to deal with, the manufacturers divide up the port area of steam entrance into six, eight or ten valve divisions. If the load is light, one valve opens and the others remain closed. As the load increases the tendency to slow down, the speed causes a second, third or fourth valve to open. These valves are hydraulically operated and are controlled by an automatic device which will close them all if the turbine speed reaches a predetermined limit.

BEARINGS.

In the Parsons type the combined turbine and generator unit is supported by three babbited bearings of

the pedestal type. In the Curtis machine there is one bearing—the step-bearing. The vertical shaft carries a cast-iron shoe on its base, which revolves with the shaft in close parallel position with a stationary plate of cast iron of similar form to the rotating plate. The weight of the rotating turbine and generator is carried on a film of oil between the stationary and rotating plates. There is sufficient pressure on the oil to remove all metallic friction. With the vertical turbine, the oil pressure under the step-bearing is about 400 lb. per. sq. in., while with the horizontal turbine the oil pressure is only sufficient to insure positive lubrication.

DIFFERENT MAKES OF TURBINES.

In addition to the two makes cited above there are several others now on the market which are well known.

The Rateau, Terry, DeLaval, are all of the impulse type and differ from each other only in details of construction. For example, the Rateau uses a special entrance system of nozzles which change in size with each stage. The Terry is like a Pelton wheel. The steam, after striking a bucket, is deflected back into the case which contains the live steam nozzle, and is there turned back against another bucket. The DeLaval is a single-stage turbine using expanding nozzles and consequently high speed on periphery and shaft. A 10-h.p. machine with a 10-in. wheel has been built with a shaft speed of 25,000 rev. per min. The peripheral velocity is about 10 miles per minute.

Horsepower Required for Metal Working Tools

By M. G. BUCKLEY.

Many tests have been made on metal-working tools, such as lathes, drills and the like, to determine the proper horse-power motor to apply. The results have been varied, indeed, depending entirely on local conditions. A motor manufacturer has summarized these tests to determine the average motor required. The following may be safely used for any ordinary installation. Where high-speed steel is used or some other condition enters into the question, then special tests must be made.

ENGINE LATHES.

22 and 24 in. . . . .	2 h.p.
26 to 30 in. . . . .	2½
36 to 42 in. . . . .	3½
48 to 54 in. . . . .	5
72 in. . . . .	6
84 in. . . . .	8

For forge lathes use motors 50 per cent. larger than above.

PLANERS.

26 x 26 in.-8 ft. . . . .	5 h.p.
30 x 30 in. . . . .	10
36 x 36 in. . . . .	10
38 x 38 in. . . . .	12
42 x 42 in. . . . .	12
44 x 44 in. . . . .	15
48 x 8 in. . . . .	15
54 x 54 in. . . . .	15
60 x 60 in. . . . .	18
72 x 72 in. . . . .	22
84 x 84 in. . . . .	25
96 x 96 in. . . . .	30
120 x 120 in. . . . .	40
144 x 144 in. . . . .	60

BORING MILLS.

10-in. swing . . . . .	12 h.p.
12-in. " . . . . .	14
14-in. " . . . . .	14
16-in. " . . . . .	15
37-in. " . . . . .	4
51-in. " . . . . .	5
60-in. " . . . . .	7
72-in. " . . . . .	7½

84-in. " . . . . .	10
96-in. " . . . . .	10

SHAPERS.

16-in. stroke . . . . .	3 h.p.
18-in. " . . . . .	3½
24-in. " . . . . .	6
30-in. " . . . . .	6½

SLOTTERS.

10-in. stroke . . . . .	4 h.p.
14-in. " . . . . .	5½
18-in. " . . . . .	6½
24-in. " . . . . .	7½
30-in. " . . . . .	7½

DRILLS.

20-in. . . . .	1½ h.p.
24-in. . . . .	1½
30-in. . . . .	3
36-in. . . . .	3
40-in. . . . .	4
50-in. . . . .	5
60-in. . . . .	5

SLAB MILLING MACHINES.

26-in. between housings	8 h.p.
36-in. " " . . . . .	12
42-in. " " . . . . .	15
48-in. " " . . . . .	15

# The Central Station Distributing System

## Transmission and Conversion

H. B. GEAR and P. F. WILLIAMS

Commonwealth Edison Co., Chicago

IN the development of a distributing system, the radius of transmission from the point of supply tends to increase as the population grows. After a time the number of feeders to certain districts remote from the generating station becomes such that the transmission may be effected at a higher voltage to much better advantage. Such transmission involves transforming and regulating apparatus at a point remote from the generating station, which in turn requires a building and other accessories, and the result is a substation. This substation involves an investment in real-estate (or a rental charge), transforming apparatus, switchboard, etc., and an operating expense for attendance and repairs. On the other hand, the feeders running into a district occupy valuable duct or pole space and require a large investment in copper and insulating materials. It, therefore, becomes profitable to establish a substation when the amount required to pay fixed charges on the substation investment and its operating expenses is about equal to that required to meet the fixed charges and maintenance expense on the feeder equipments which would be required if a substation were not installed. In a growing system it may be advisable to anticipate this point somewhat and install the substation earlier, in order to avoid the loss due to the installation and removal of feeders which are transferred to the substation after but a few years service.

The point at which the balance between substation cost and feeder cost is struck varies widely with different systems and classes of construction. In a low tension direct-current underground system, the number of substations is usually greater than in an alternating system with 2200 volt mains because of the shorter radius of action in low-tension systems.

There are also many local conditions to be considered and two problems are rarely, if ever, identical in every particular. With a given class of construction, the radius of distribution and therefore the number of substations is fixed by the voltage of distribution, and second by the load.

With a feeder loss at maximum load of 10 per cent. the length of a feeder is approximately one mile for each 1000 volts of feeder pressure. On this basis the radius of distribution at 220 volts is 0.22 mile or 1100 ft., and at 2200 volts it is 2.2 miles. There are usually some feeders which are longer than this on which the loss runs higher. When these become sufficiently numerous an additional substation becomes necessary.

It is sometimes necessary to establish a substation on account of a large block of load, such as an amusement park, large retail store, manufacturing plant, or other similar enterprise.

The selection of a system of transmission for the wholesale distribution of energy from the generating station to substation is a matter of great importance. The three-phase system is used almost universally for this purpose, owing to its inherent economy of copper, reduced cost of generating apparatus and its adaptability to rotary converter and motor generator work.

The voltage employed in the transmission system should be high enough to permit the economical supply of the most remote sections of the city, and, if possible, should be capable of reaching suburban substations. This usually does not require a voltage higher than 13,000, which permits the use of generators wound for the transmission voltage without step-up transformers.

In the larger cities where the loads to be transmitted are very great in proportion to the distance, it is desirable to use a voltage high enough to keep the transmission cables within reasonable limits of size. Voltages up to 20,000 have been found desirable in some of the larger cities in connection with transmission to suburban substations.

Where the major portion of the energy generated is not distributed from the generating station but is transmitted to substations for distribution, the generators should be wound for the transmission voltage in order to save the expense of step-up transformers.

The voltage selected should be one which is standard with manufacturing companies in order to secure lower

first cost, and to facilitate delivery of coils and other apparatus which may be required for repairs.

In American practice, two frequencies are standard for transmission purposes, namely: 25 and 60 cycles per second. Other frequencies, such as 30, 40 and 66 cycles, are in use to a limited extent, but are not considered standard. Twenty-five-cycle current is found preferable when the major part of the energy transmitted is converted to direct current for distribution. This is so because of the fact that rotary converters are much more stable in their operation at the lower frequency than they are at 60 cycles.

Where transmission is effected by underground lines the charging current of the cables at 60 cycles becomes an important factor in a large system and may result in high potential surges in the transmission system in connection with switching operations, synchronizing and disturbances, due to the occurrence of short circuits or grounds.

Twenty-five-cycle current, however, cannot be used for arc lighting and is not in general use for incandescent lighting, except out of doors, owing to the noticeable flickering of the light. It is, therefore, customary to convert the energy to 60 cycles for distributing purposes where 25-cycle energy is used in transmission. Sixty-cycle motors and transformers are less expensive than 25 cycle, which further favors the use of the higher frequency for distribution.

In a system embodying a number of substations and perhaps more than one generating station, the design of the transmission lines supplying each substation with reference to continuity of service becomes a matter of great importance. The larger and more important substations should have at least two sources of supply, one of which should be a separate transmission line direct from the generating station to the substation. The second line may be a tap from a line which acts as a reserve for two substations. In some cases the line may be tapped at an outside point and in other cases the geographical arrangement permits one line to be looped into the substation nearest the power-

house, so that the line from this substation to the farther one becomes a tie line. Such a tie line, when provided with a suitable arrangement of switches and bus connections, forms a very desirable reserve supply for both substations, as it can be fed from either end.

In a low tension direct-current system with storage battery reserve, the



smaller substations, which are operated only during the heavy load period, are sometimes so located that the expense of having reserve transmission line capacity is so great as not to be justifiable.

The development of a portion of the transmission system in the City of Chicago up to 1908 is illustrated in Fig. 1. It will be noted that in this system there are two generating stations producing 25 cycle, 9000-volt current and several subsidiary steam plants, which are operated only during the heavy load period of the winter months. This system is somewhat different from that of other large cities in that several of the direct-current substations are used exclusively for the supply of 500-volt current to street railway companies and elevated roads. It will also be noted that practically all of this system is underground, there being approximately 270 miles of three conductor 9000-volt cable in service.

Substations may be divided into three general classes:

- A. Those delivering alternating current from static transformers.
- B. Those delivering alternating current from frequency changing motor generators.
- C. Those delivering direct current.

Fig 1.

In the first class, those delivering alternating current from static transformers, the equipment is comparatively simple. The incoming transmission lines supply a high-tension bus

through oil switches. The step-down transformers supply to the distributing bus the proper pressure and from this bus the outgoing feeders radiate after passing through their potential regu-

lators. Ammeters, volt meters, lightning arresters and other accessories which are necessary for the proper operation of the equipment and for record of the output complete the equipment. There being no moving apparatus, a single attendant at the switchboard can properly care for pressure regulation, make minor repairs and keep the equipment in condition in most cases. The transformer units should be so selected that the failure of a unit will not remove too much of the capacity of the substation. A spare unit should be at hand which can be quickly put into service in emergencies.

this may become a serious difficulty, owing to the space required for the air ducts. The circulation of water or oil permits more rapid cooling, and is, therefore, desirable in the larger units in order to keep the first cost of the transformer within reasonable limits.

The outgoing feeders should be equipped with oil switches capable of opening under load and provided with overload relays set to operate them in case of short circuit. Transfer and tie switches and others which are not required to be operated under load may be of less expensive design.

All instruments measuring high po-

cause of the fact that the windings may be designed for the transmission voltage and the expense of transformers thus avoided. The control of the power factor is also a great advantage. The 60-cycle generators deliver a pressure suitable for the distributing feeders, and the switchboard and its equipment are therefore similar to that employed in a transformer

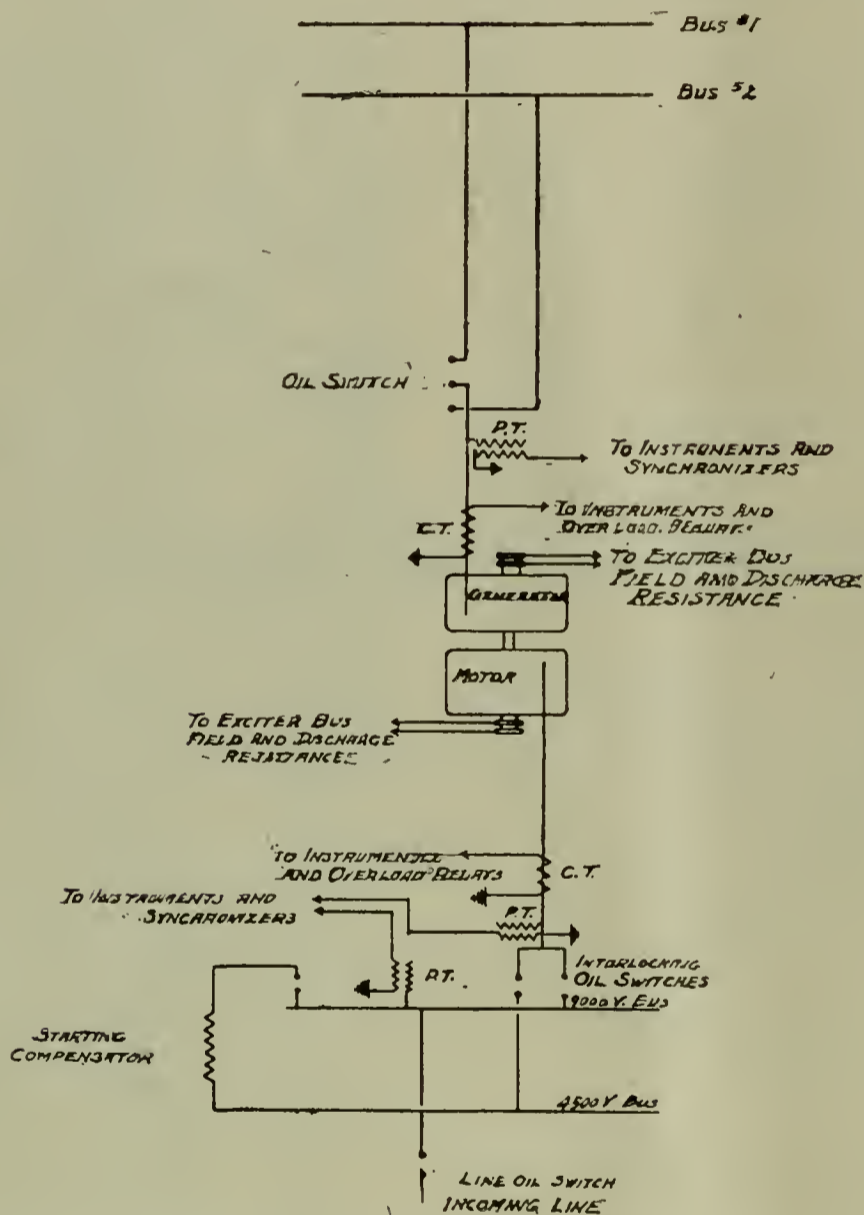

Fig 2.

The transformer equipment may be of the air-blast type, oil-cooled, water-cooled, or of the more recently developed oil-cooled type, in which the oil is circulated through the transformer by means of a system of piping and an external pump and radiator which carries away the heat.

Where overhead lines are used the oil-cooled transformers are less subject to puncture by lightning or high potential surges.

Air-blast transformers involve blowing apparatus and ducts for the fresh air supply. In a large substation

tential energy should be supplied through transformers, the low potential circuits and transformer cases being carefully grounded to prevent injury to operators or construction men.

In the second type of substation, the supply of alternating current for distributing purposes is derived from frequency changing sets. These consist generally of synchronous motors driving 60 cycle generators, motor and generator being mounted on the same shaft. Synchronous motors are found desirable for this class of work be-

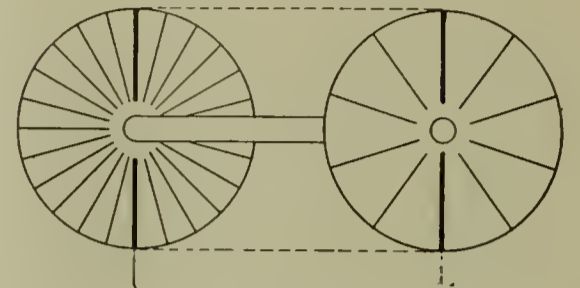

Fig 3.

substation. The essential elements of such a substation are illustrated diagrammatically in Fig. 2. The chief point of interest about such a substation is the method of starting and synchronizing the motor-generator sets. When a unit is to be put in service it is transferred to a starting bus, which is supplied by an auto-transformer which delivers about 40 per cent. of the transmission line pressure to the starting bus. The switches controlling the direct current for the fields

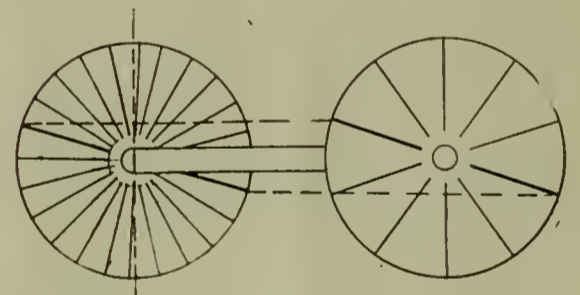

Fig 4.

of the motor are left open. The oil switch controlling the motor is then closed on the starting bus and the unit begins to revolve as a hysteresis and induction motor. When the unit is at approximately synchronous speed the field is excited and the unit is drawn into step as a synchronous motor. This usually causes a rush of current for a very brief interval of time, as the machine may be out of phase at the time the fields are excited.

When the conversion is from 25 to 60 cycles this usually does not complete the operation of synchronizing, as the 60-cycle generator is not necessarily in phase with its bus when the 25-cycle motor has been synchronized. The ratio of field poles on the 25-cycle motor to those on the 60-cycle machine must be as 25 is to 60 or as 10 is to 24. When a 10-pole field is mounted on the same shaft with a 24-



pole field, as is usually the case in a 25-60 cycle frequency changer, only one set of poles on each field can be lined up in the same radial place. In Fig. 3 the poles which are aligned in the same radial plane are represented by the heavy diameters. When the 25-cycle machines are synchronized, any of the five sets of poles on the incoming machine may fall into step with the poles represented by the heavy line on the operating unit. Fig. 4 represents a unit in which the 25-cycle machine has fallen into step with



Fig 5.

a displacement of one pair of poles. This holds the incoming 60-cycle machine out of phase with the operating unit, as shown by the dotted vertical line. If the rotation is counter clockwise, the machines can be brought into phase by removing the supply of energy from the incoming machine and allowing it to slip back one pair of poles until the heavy lines are in phase with each other. The machines are then in phase on both 25- and 60-cycle ends. The operation is carried out thus:

When the 25-cycle machine is locked in step by the excitation of its fields, the 60-cycle synchronoscope pointer assumes one of five positions, as in Fig. 5. If it comes in on No. 1 the oil switch is opened, cutting off the supply of power to the motor and it begins to slow down. When it has slipped back one pair of poles the 25-cycle synchronoscope pointer will have made one revolution and the 60-cycle synchronoscope 2.4 revolutions. This brings both synchronoscope pointers into a vertical position and the oil switch is closed at this moment, locking the motor in step again. The motor is now thrown to full pressure, and the 60-cycle generator connected to its bus.

If in synchronizing the 60-cycle pointer had taken position No. 4, it would be necessary to "slip poles" four times before the 60-cycle machine could be thrown in.

These complications do not arise in synchronizing a single frequency changer with a 60-cycle generator driven by a prime mover, as the phase of the generator can be adjusted to any point by adjusting the governor slightly.

The supply of direct current for the excitation of the fields of the motor and generator may be derived from direct-connected exciter sets or from separately driven exciter units, which may be used interchangeably with any motor generator. Where more than one unit is operated the use of separately driven exciters allows greater flexibility of operation, and is, therefore, usually preferable.

Where direct current is used for the operation of auxiliary devices or for automobile charging, it is very important to have separate exciter units, so that the variations of load due to auxiliary apparatus will not affect the

units for this purpose. The switch-board containing the controlling apparatus for the exciter system and 60-cycle generators and feeders appears in the background. The vertical unit is carried on a step-bearing similar to that which has been developed for the Curtis turbine. Several of these units are in service in the City of Chicago. The special advantage in their use is a saving in floor space and investment.

The third class of substation supplies direct current to a low-tension network through the medium of synchronous converters or motor generators.

The electricity received from the transmission system passes through suitable oil-switching arrangements to step-down transformers, which deliver a secondary pressure suitable for the rotary converter. From the transformers the current passes through a

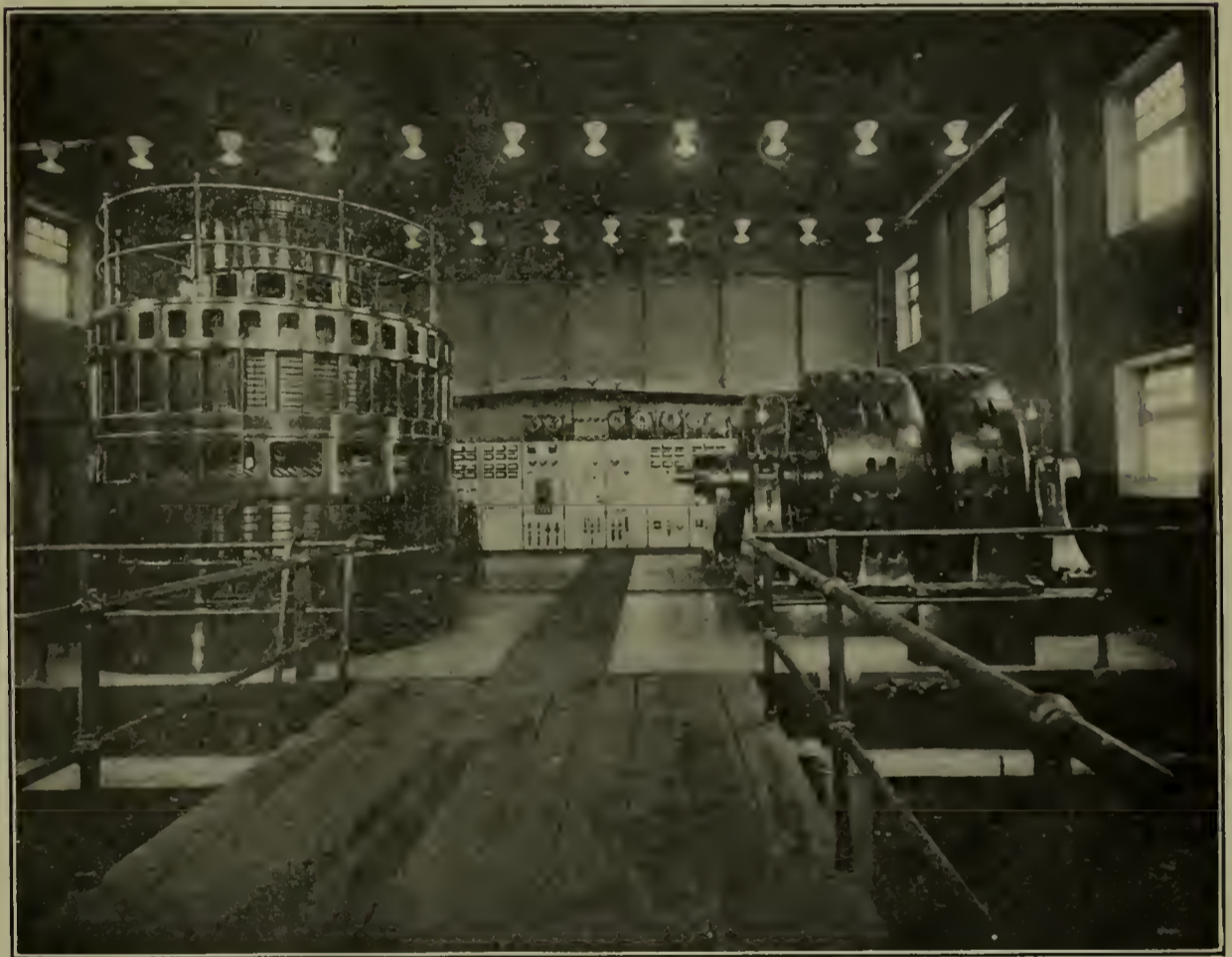

Fig 6.

generator fields. A typical substation of this class is illustrated in Fig. 6. The two horizontal units are rated at 1000 kw. each, while the vertical unit is rated at 2000 kw. The exciters for the horizontal units do not appear, but it will be noted that the exciter for the vertical unit is mounted at the top, the armature being carried on the main shaft. In this substation the exciter for the 2000-kw. unit is provided with suitable switching arrangements, which permit its use as a direct-current motor in bringing the unit up to speed. Direct current is supplied from one of the other exciter

potential regulator to the collector rings of the converter and thence through its windings to the commutator from which direct current is delivered to the brushes. The direct current passes through a circuit breaker and switch to its bus-bar, from which the feeders are carried to the distributing mains. A group of feeders may be isolated on one bus during the heavy load period and thus regulated separately. An ammeter is provided on each outgoing feeder and such other instruments as are required for a proper record of the output are installed on the converter panel. A

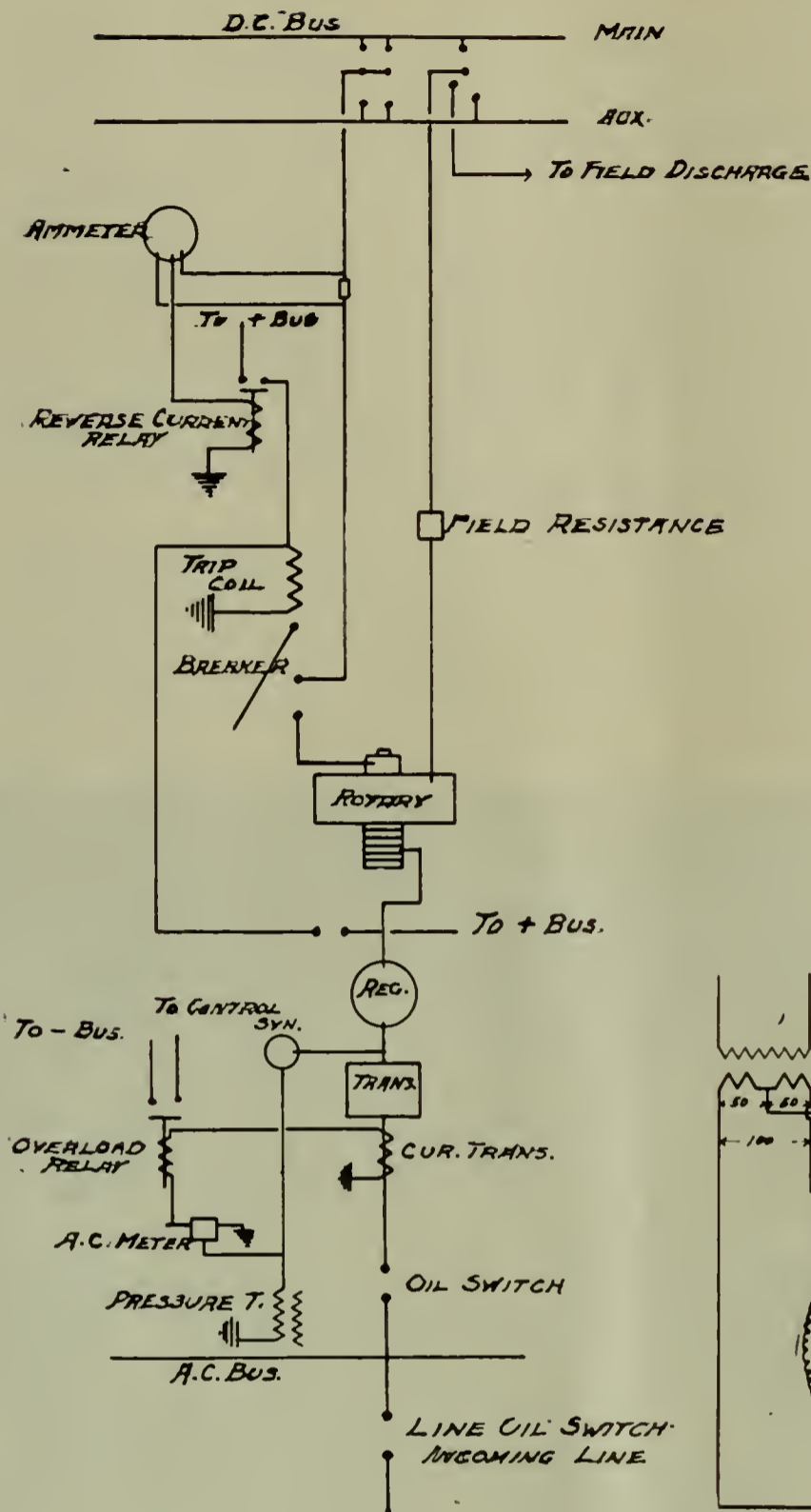

Fig 7.

voltmeter is required on the incoming transmission line. The essential elements of a converter substation are illustrated in Fig. 7.

The three-phase shell type of transformer, air cooled, has been used quite generally for this class of service, owing to the economy in first cost and in floor space. The cross-section of the core is shown in Fig. 8. The middle section of such a unit must be connected up in a reversed sense in order to maintain the same magnetic density in each limb of the core. The air for cooling is blown through ducts within the case, and in substations of 2000 kw. or more, it is sometimes necessary to provide ducts to carry the heated air outside the building. This may largely offset the saving otherwise effected.

In a large three-wire Edison system it is desirable to use converters wound for the voltage across the outer wires, in order to avoid the multiplication of the number of units, and the increased expense incident thereto. The unbalance of the system may be cared for by one pair of 110-volt machines or by a motor-generator balancer set, or by the use of six-phase diametrically connected transformer secondaries arranged as in Fig. 9. The latter plan has the great advantage that no 110-volt machines are required in the substation and that six-phase converters may be used with a greatly increased output from a given sized machine. The neutral of the direct-current system is connected directly to the secondary neutral of the transformers, and any unbalance is thus

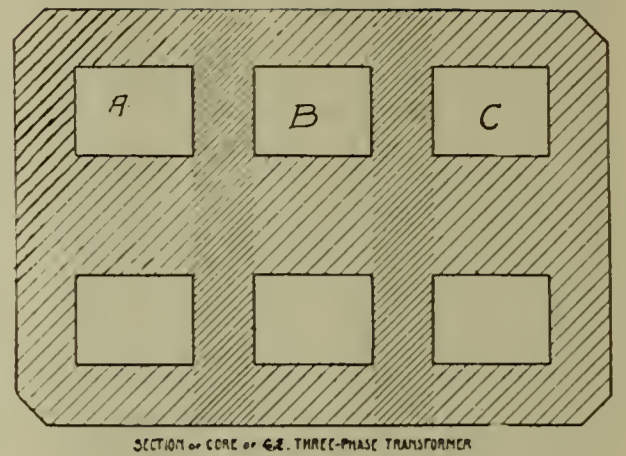

Fig 8.

cared for. The unbalance in a large system is rarely over 5 per cent. and the scheme is found very satisfactory in most instances.

The use of the six-phase connection and converter winding reduces the length of the path traveled by the current in passing through the armature and thus reduces the losses and the heating. Theoretical calculations based on sine waves indicate that a direct-current generator rated at 100 kw. may be rated at 131 kw., as

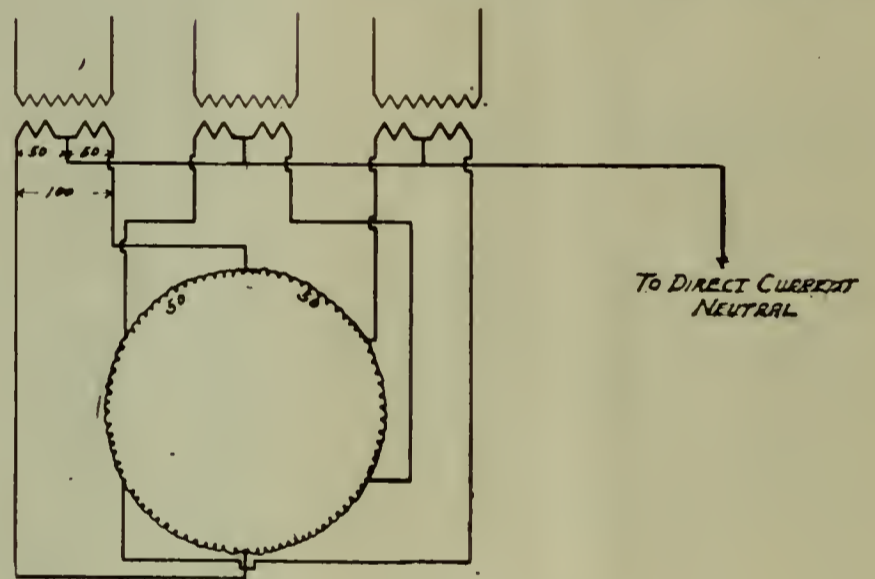

Fig 9.

a three-phase converter, or at 194 kw., as a six-phase converter.

The theoretical ratio of transformation in voltage in passing from the collector rings on the alternating-current side to the direct-current brushes is, approximately, as 61 to 100 in a three-phase converter and as 71 to 100 in a six-phase converter. These are based on the assumption of a sine wave of electromotive force and may, therefore, vary somewhat in actual practice.

It will be noted that the converter is protected by a reverse-current relay, which opens the circuit breaker in case the flow of energy is reversed, as in the case of a break-down in a transmission line, and shuts the machine down. Without such protection the reverse current might weaken the

fields of the converter and cause it to speed up quickly to a dangerous speed. The reverse-current relay does not usually operate below 20 per cent. of full load, and a speed limit, consisting of a centrifugal switch, is provided as further insurance against dangerous peripheral speeds. The speed limit is rarely called upon to act, and should, therefore, be tested at regular intervals. Accidents to converters in which machines have been wrecked have occurred in nearly all large systems, and the provision of such accessories must not be overlooked where the unit operates in parallel with a direct-current system having other sources of supply.

As variation of the bus pressure by means of the field rheostat cannot be had without interference with the power factor in an ordinary synchronous converter, it is necessary to provide a potential regulator. This is preferably of the induction type and is placed on the secondary side of the transformer between the transformer and the converter. This location being remote from the operator in many instances, the regulator is usually operated by a small motor controlled from the main board.

Recently there has been developed a type of converter having split poles which are so designed that a considerable range of pressure regulation by means of the field rheostat is permissible, without serious interference with the power factor.

The arrangement of starting devices for synchronous converters is a matter of great importance, as it must be possible to start them quickly and without serious disturbance to the system in regular operation and in emergency. The converter may be started by either of three general plans, viz.: a supply of current to either side of the machine or by external power supplied by a starting motor direct-connected to the shaft. When started from the direct-current side, a rheostat is used in series with the armature, as in starting a direct-current motor. The starting current, however, has two paths, one through the converter windings from brush to brush, and another through the collector rings to the transformer coils and thence back again to the converter armature. While the converter is turning slowly the frequency of reversal of current through the transformer coils is low and the choking effect is small. The starting current from the direct-current side is, therefore, more than that of a motor of the same size without load. When the machine has come up to speed the potential regulator is adjusted to bring the alternating-current pressure of the rotary converter up to that of the transmission system. The alternating-

current side of the rotary is synchronized with the transmission system and connected to it. The field is adjusted to bring the power factor up to unity and the potential regulator is used to adjust the load carried by the unit to the desired amount.

In case a total shut-down of the system removes the supply of direct current for starting, means must be at hand for starting from the alternating-current side with the field coils open as in starting a synchronous motor, and the pressure reduced to about half normal pressure to keep the starting current within limits. This may be done by means of a starting compensa-

The starting current required in starting from the alternating-current side is from 150 to 200 per cent. of full-load current on a 500-kw. converter and somewhat less on larger sizes. The direct-current starting current, however, is but 25 to 30 per cent. of full-load current, and this method is, therefore, preferred for regular operation. Sufficient machines are equipped for alternating current or motor on the shaft starting in a given substation to insure a supply of direct current for starting the other units. Where sufficient storage battery capacity is installed the direct-current supply may be relied upon at all times.

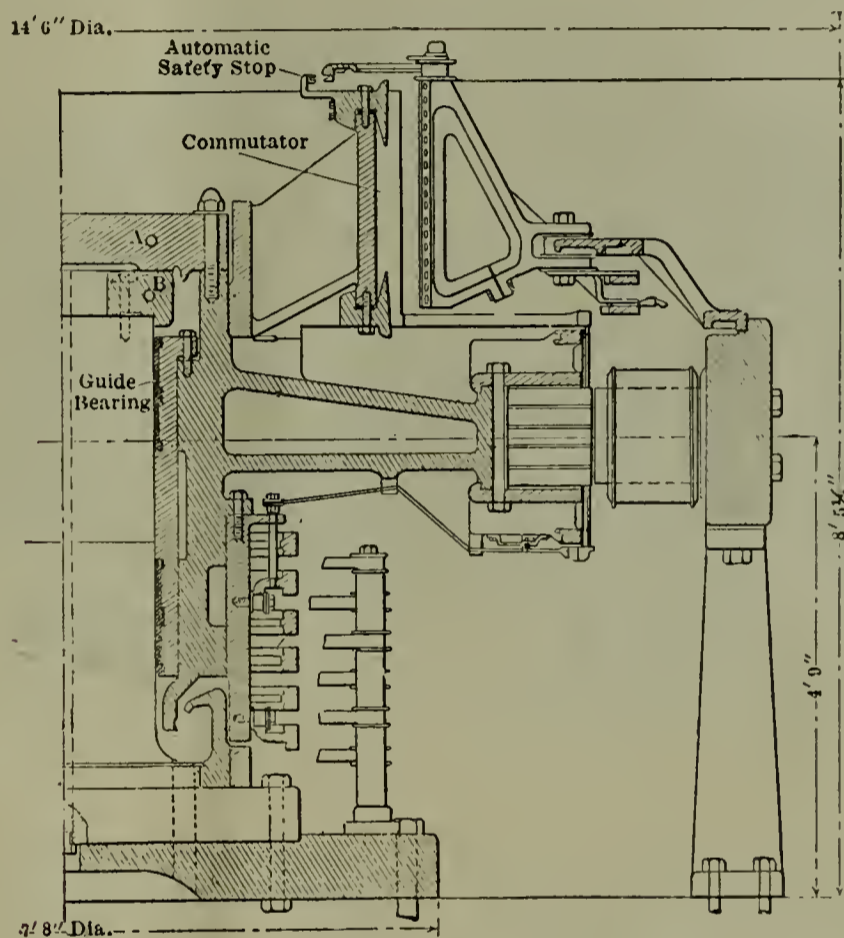

Fig 10.

tor on the high-tension side of the transformer, or by means of taps on the secondary winding. The latter is preferable, as no auto-transformer or extra high-tension switching operations are required.

In this method after the machine is brought up to speed, its fields are excited and the polarity noted, as it may come up reversed. If so, the direct-current voltmeter on the machine gives a negative reading. The field connections are then reversed by means of a switch provided for the purpose and the machine slips back one pole. As soon as it has done so the direct-current voltmeter swings to a positive reading, when the field is again reversed and the polarity remains correct. The starting switch is then thrown to the full pressure and the machine is equalized and thrown on to the direct-current bus.

The smaller starting current required in starting from the direct-current side makes this method preferable in cases where there are several machines, or where the direct-current distributing system has sufficient capacity to furnish the starting current without serious disturbance. In such cases the normal method of starting is from the direct-current end.

The synchronous converter has also been adapted to operation on a vertical shaft after the manner of the frequency changer described in the foregoing. This machine is, however, supported on a bearing which operates on a pedestal that passes through the center of the machine to the top. The bearing is thus accessible from the top by the removal of a plate, instead of from below. The general arrangement is illustrated in cross-section in Fig. 10 and the external appearance in Fig. 11.

These machines have been made in units of 1000 and 2000 kw., the first of this type having been installed in Chicago in 1907.

The use of motor-generators for conversion to direct current is sometimes resorted to in preference to synchronous converters. When the transmission system operates at 60 cycles, the use of converters is subject to some disadvantages, and it is, therefore, usual to find motor-generators in direct-current substations which derive their energy from a 60-cycle system. The inherent characteristics of a

One of the principal advantages of the direct-current system of distribution is the possibility of the use of a storage battery reserve. Before the use of the battery became general it was not an uncommon thing in the larger systems to have the service seriously interrupted through a comparatively small accident in the generating or transmission system. With the introduction of the storage battery these interruptions were limited entirely to serious accidents affecting the major part of the equipment. Such smaller disturbances now occur

preventing a complete interruption. The extent of the interference depends upon the relative capacity of the battery and the load on the bus at the time. During the hours of light load the operator's adjustment of the end-cell switches is sufficient to restore the pressure to normal in a very short time, so that the consumer notices nothing beyond a slight flickering in the lights.

As the peak of the load in a large system is usually considerably greater than the average load, it is not feasible to provide sufficient battery to care for a serious accident at that hour. The chances of the break-down occurring at this time being rather remote, and the maintenance of batteries being expensive, it is not usual to provide more than 25 to 40 per cent. of the maximum load in battery capacity.

Two buses are provided, so that the battery may discharge simultaneously to main and auxiliary buses at different pressure. It is also desirable to keep the battery floating on the main bus while it is being charged through another bus. This battery may be charged through a booster from the main bus, or from a separate converter or generator wound for the higher pressure required for full charging.

The battery as installed in American practice is usually arranged for motor control of the end-cell switches with indicators on the switchboard to show the operator the position of the end-cell switches on each bus, ammeters on each bus reading both ways, and pressure connections by which the voltage of each end cell may be ascertained whenever desired.

The method of operating, and maintaining a battery involves a great many important details, which need not be elaborated in this connection, as they are fully covered in special works covering all phases of the subject.

Circumstances make it advisable in some cases to combine direct current with an alternating-current substation, the direct current being distributed in the immediate vicinity, and the alternating current being used for a scattered load beyond the range of the direct-current lines.

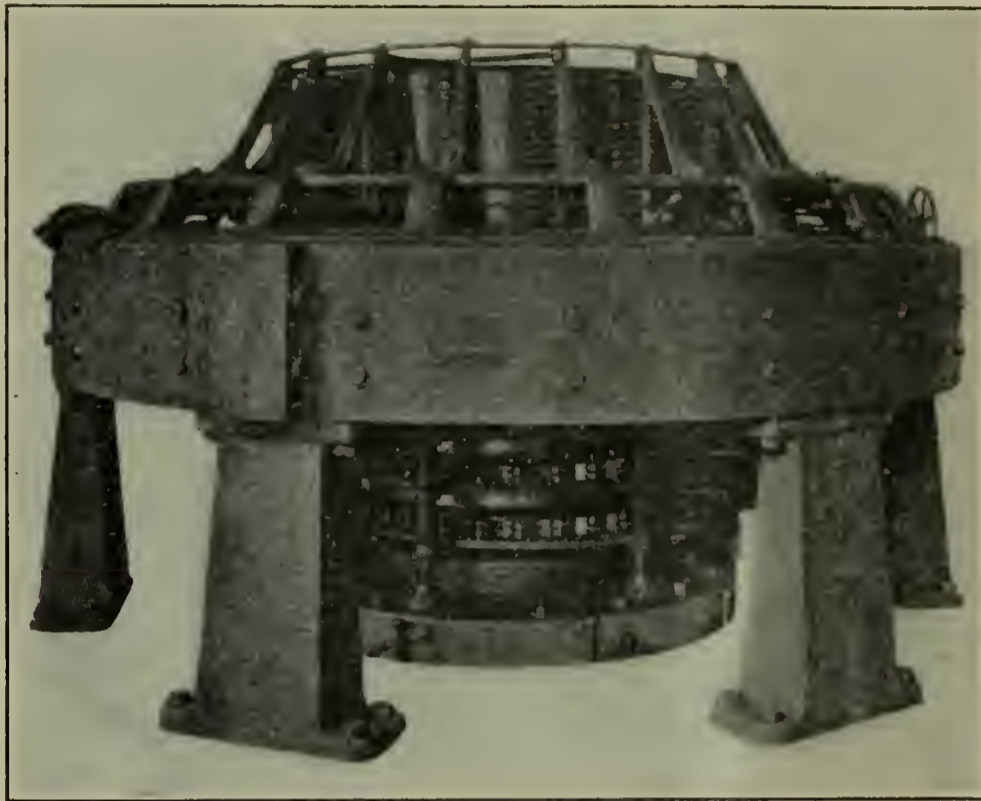

Fig 11.

60-cycle converter are such that it is very sensitive to fluctuations in frequency or voltage, which causes hunting and sparking at the brushes when conditions are unfavorable. Such converters must be provided with copper rings about the pole pieces in order to damp the tendency to hunt. These difficulties are reduced in a system which derives its energy from turbine-driven generators, owing to the absence of a reciprocating motion in the prime mover.

The motor-generator is subject to the handicap of greater first cost and lower efficiency than the converter. If induction motors are used the stability of the system is increased in times of disturbances of short duration, as induction motors will continue to operate when synchronous motors and converters are thrown out of step and shut-down. The necessarily low power factor of the induction motor may be partially compensated for by the use of both induction and synchronous motors in the same substation, the synchronous motors being so excited as to supply the lagging current for the induction motors.

in a large system without appreciably affecting the service. The usual arrangement of battery connections is shown in Fig. 12. The cells from which taps are brought out are known as end cells and are used as follows:

Connection is made from each battery terminal to a bus-bar by a sliding contact C, which bridges the gap between the bus-bars and the terminal as it is moved along. The voltage of each cell being about two volts the pressure delivered by the battery to the bus-bar will vary according to the position of the sliding contact. When the battery is required to discharge the sliding contacts are moved toward the outer ends, thus raising the pressure of the battery and causing it to deliver energy to the bus-bar. When no energy is required from the battery, the end-cell contact is set so that the battery pressure and bus pressure balance, and the battery floats on the system. In case of a reduction in the bus pressure, due to a failure in the supply of energy, the battery pressure causes the battery to discharge to the bus, thus holding up the pressure partly and

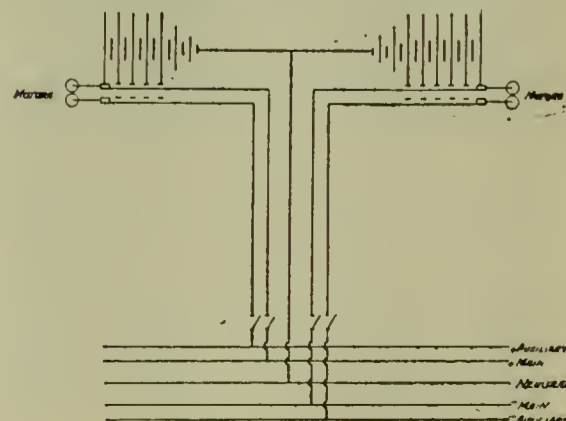

Fig 12.

# Tape

PAUL LUPKE

DICKENS, in his usual extravagant way, in "Prince Bull" says this: "She was a fairy, this Tape—she could stop the fastest thing in the world, change the strongest into the weakest, and the most useful into the most useless. To do this she had only to put her cold hand upon it and repeat her own name, Tape. Then it would wither away."\*

Now we are told that hard in the wake of combinations, consolidations and nine-hundred-and-ninety-nine-year leases there sneaks this same bad fairy, Tape. But—do you believe in fairies? I say, don't; at least not in business fairies; it is a poor policy. Deal with facts absolutely and entirely, and fairies, good or bad, will never trouble you. They are created merely for the weak, who try to hide their own shortcomings behind the skirts of fancied grievances. Never mind what Dickens says—tape is a necessity. With the growth of every business the time comes when it begins to be impracticable to have Tom, Dick and Harry meddle in everything and anything that concerns the company. The man who cannot bring himself to realize that had better quit right then and there, for tape—red tape, if you will—there must be to prevent chaos; but those charged with its manufacture face a grave responsibility.

Law is imperative, yet "that country is best governed which has the least law." Rules must be designed to assist individual judgment, not to stifle it. The attempt to cover every specific instance by a general rule promotes indifference. Write all the rules you please while the spirit moves you, but never send them out till you are sober. There is the possibility of making the remedy worse than the evil. Remember the Shildburgers? They complained to the town council that the game-warden on his rounds trampled down too much of their grain. "We will soon remedy that," decreed the council, and forthwith appointed four strong men to carry the warden. Don't emulate that example.

What is needed most is a conscientious cultivation of the sense of proportion. For instance: I claim that when my boy was taught in school that Africa has 174,396,413 inhabitants a great wrong was done him. Such perverted accuracy must unduly twist the sober sense of judgment of

the relative importance of things. How many of us keep on counting the inhabitants of Africa to the last man all through our lives? Did you ever see a gang of forty-cent-an-hour line-men wait patiently—and willingly, forsooth—while a nine-dollar-a-week storeroom clerk figured out the cost of a four-inch spike to the seventh decimal point of a cent? It is a sign of greatness to be able to judge when the seventh decimal is worth while. Perhaps it is most essential in scientific investigation, for behind it Nature may hide one of her well-guarded secrets, but the seventh decimal in every-day routine is an unmitigated nuisance. Yet, says the auditor, we must have it to keep our pennies straight. True, a penny one way or the other may be worth a war, if it involves a principle, but the man of the hour is he who can find the way to keep principles and pennies at a safe distance. If you insist upon carrying the supposed accuracy of your accounting one single point beyond that warranted by the limit of correctness of its basic data you are foolishly and recklessly wasting time, money, and the very life-blood of men.

Intelligent approximation is a high art sorely neglected. Figures should not be relied upon to the exclusion of common sense. Of course figures don't lie, but for that very reason they furnish the liar his sharpest tools. We are apt to become slaves of figures and worship the golden calf of averages and percentages. At the end of every month we reduce an avalanche of reports to a few neat sheets of bare figures, a sort of skeleton *de luxe*, the dry bones of which are rattled industriously in executive session and—well, the devil may catch the hindmost, or *vice versa*. Chasing figures with explanations is a sad job. Mere figures climb to places where explanations cannot follow. So much for that.

Furthermore, in laying down the laws for the company the intimate interdependence of the departments must have most careful consideration, else there can be no successful parallel operation. The necessity for specialization under modern conditions often places at the head of a department a man whose knowledge of the operation of other departments is confined to what might be termed a course in the intra-company correspondence school, and in that case the value of

an efficient clearing-house cannot be overestimated. Without it rules will clash, the same information will be asked for in half a dozen different ways, multiplying uselessly the labor necessary to get it together, the general good will be sacrificed to the whim of the individual, meritorious effort will be strangled, ambition embalmed, and a dead "what's the use?" feeling will begin to permeate the system. The conclusions of a man who refuses to look beyond his own nose, no matter how long that may be, will lead him into the wilderness.

Still another point. Nothing will promote economy more effectually than a continuous uniform rate of production. We fully realize that in the operating department, and are moving heaven and earth, and justly so, to find means to flatten the peak unalterably imposed upon our stations by the revolution of the earth once in twenty-four hours; yet we deliberately create an entirely artificial monthly peak in our commercial, accounting and business department, for which, in the last analysis, no more valid reason can be advanced than that the moon travels around the earth somewhere in the neighborhood of once a month. What a boon the elimination of this peak would confer upon an army of weary men, whose energies are indeed fully taxed in handling the tape that most careful and wise administration demands!

In handling this tape there are really but two points to be observed: they are strict compliance with the rules and the avoidance of errors. An immense amount of smooth red tape can be reeled off in record time, provided you take care not to get it into a snarl. In the complex system of a large concern errors are positively hydra-headed, and not every clerk is a Hercules. The only way to treat an error is to kill it a-borning; once it sees the light of day it devours time and paper in prodigious and ever-increasing quantities. A runaway error is harder to stop than a slander.

With all due precautions taken to avoid them, there will crop up now and then, among the complexities of necessary tape, some really weird excrescences. How shall we treat them? Little good will result from combating ingenious foolishness with tillmanesque ferocity; sarcasm will always be paid for in counterfeit coin. Neither is it well to try to do a rule to death by quixotic superobservance;

\*Read before the National Electric Light Association at its Thirty-first Convention, held at Chicago, Ill., May 19-22, 1908.

you run the risk of being done first. Nor yet is it well to skip over it in a careless, perfunctory way, like that particular type of Bridget who is always done. According to her notion, dinner was invented for the sole purpose of having it over with. It is the wiser plan to use sober reason persistently; nothing inherently wrong can stand long before it.

But there remains one case where individual judgment must rise above all rules—that is, an emergency. An emergency, provided he has taken every precaution to prevent it, is a man's greatest opportunity. He who in the fierce glare of an emergency hides in the protecting shadow of a rule might as well acknowledge himself a coward, for, if he is a man at all, he will forever after carry with him the gnawing consciousness of failure.

After all is said, the backbone of a company is not its rules, but its men. No concern of magnitude has any use for heroic individualism of the hermit type, but there is a crying need for honest, loyal, collective individualism.

Out of the maze of filing cabinets, where card indices innumerable gather dust in their polished metal-trimmed caskets; above the beavies of typists who clatter away feverishly at the keys between primping and candying; above the horde of clerks wallowing in quadruplicates; above the groups of petty officials, who deem it their principal duty to dictate reams of letters to be handed across the corridor—there must always rise a select few, firm of grip, clear of view, broad of mind, who will absolutely dominate red tape. Try, you, to be one of them. Relegate relentlessly to some one else all the things that some one else can do as well as yourself. Thoroughness does not mean indiscriminate attention to an agglomeration of petty details; it means the intelligent elimination of unessentials and a firm grasp on matters of vital importance. Let it be your constant aim so to manage affairs in your care that they will run smoothly and efficiently without you; for the moment you have reached that point invariably coincides with that of your promotion. The battle will always be to the strong, sacred as well as demagogic generalities to the contrary notwithstanding. Never flag. Retrogression begins the moment you are firmly convinced that you are doing your best; there really is no best. Hundred per cent. efficiency and perpetual motion are synonymous. Meritorious effort and genius forever try to approach them; ignorance and madness alone claim to reach them. Be always on guard, for as soon as you begin to count upon what you have done yesterday, and not what you are doing to-day or what you are able and

willing to do to-morrow, it is the proper time to hand in your resignation if you would avoid unpleasantness. When you arrive at that state of mind where everything anybody else does is absolutely no good; when all changes and innovations are utter rot; when you feel more like throwing a handful of sand into the business machinery than using the oil can; when you become a slave of conditions instead of being their master, you are old, brother—you are ripe for the pension list and half pay.

The company man needed and wanted is he who can stoutly and with ability defend his own opinion while a matter is under discussion and open to argument, and who, if overruled, is broad enough to bring his best efforts, with true loyalty, to bear upon making an unqualified success of the opinion that prevailed; in short, a company man must be able to abide by the decision of the court and go to work. Concerted action of men who have minds of their own must always be based on a compromise. Though we cannot all get what we think is best, we must nevertheless all do the best we can with what we get. He who goes off nursing a grudge, sulking behind petty routine, waiting and watching for the time when he may crawl out of his hole with a doleful "I told you so," will soon find himself forgotten. The chances are that he will be shriveled and dry before his opportunity arrives.

But in all our efforts let us never forget that, besides being company men, we are also men—just that. Let us not fail to observe that the world is slowly recasting valuations. Raw dollars are not worth as much as they were some years ago, still there are men who, having sold their souls to success, keep on counting dollars above all else, and they will probably die doing it. My appeal is to the young men—you whose actions will determine the fate of the nation for the next generation—yet I cannot find words adequate to take the place of these, which, though spoken over 60 years ago, seem more timely to-day than ever before. I will but humbly repeat them in the fond hope that you may heed their lesson:

"—And, further, I will not dissemble my hope that each person whom I address has felt his own call to cast aside all evil customs, timidities and limitations, and to be in his own place a free and helpful man, a reformer, a benefactor, not content to slip along through this world like a footman or a spy, escaping by his nimbleness and apologies as many knockes as he can, but a brave and upright man, who must find or cut a straight road to everything excellent

in the earth, and not only go honorably himself, but make it easier for all who follow him to go in honor and with benefit."

"After all is said, the backbone of a company is not its rules, but its men."

#### Something Worth Knowing About Direct-Current Meters

Tests on a certain type of D. C. meter show that a bus bar carrying 600 amperes at a distance of 12 inches from the meter was found to affect its accuracy at one-tenth load over 50 per cent., the direction of the current in the bus bar determining whether the meter was this percentage fast or slow. The error is largely dependent on the position of the bus bar with relation to the meter, as the same current with the bus bar only two inches from the meter in another direction had no appreciable effect on its accuracy. In actual practice a case is reported of a 600 ampere D. C. meter in perfect condition which would not register on a load of 80 amperes on account of the opposing field from an adjacent conductor. Meters may also be influenced by their own wiring, if the service or load wires are brought around the meter. In another case reported from actual practice, a 150 ampere D. C. meter registered only 90 per cent. of the load passing through it on this account.

Meters are also somewhat affected by their proximity to each other. In tests on D. C. meters where three meters were placed side by side with 12 inches between centers, it was found that the middle meter was affected from five to 10 per cent. on one-twentieth load when the other two carried a full load. To be free from this effect meters should be installed with about 15 inches between centers. While the instances cited are from D. C. meters, some makes of A. C. meters are nearly as much affected by external fields as are the D. C. meters.

It will at once be seen that the installation of meters on switchboards or close together in meter closets, where they are also frequently very near the building risers, may give rise to considerable metering errors which might be avoided by a more judicious location of the meters. The matter is one which merits the careful attention of our companies and information can doubtless be obtained from the meter manufacturers if requested regarding possible errors from this cause. There has recently been designed for use where external fields cannot be avoided, a four-pole D. C. meter which is much less affected than the ordinary two-pole type.—*Meter Committee Report—N. E. L. A., 1908.*

# Receiving Stations Operated from High-Tension Transmission Lines

S. Q. HAYES

THE design of receiving stations operated from high-tension transmission lines has become of vital importance to those responsible for obtaining the best results, and the main features involved in such station design warrant careful consideration.

The term "receiving station," as used in this paper, covers stations where practically all of the electrical power is received over one or more incoming feeder circuits from other stations where it is generated by steam or water-power. Auxiliary steam or water-power may be available in a receiving station for an emergency or to assist in carrying the peak load, but the bulk of the power is received.

In taking up the details of the apparatus used in such stations, it will be obviously impossible even to touch on all of the different types, so one particular line of apparatus will be considered and compared with other conflicting designs.\*

The matter of suitable equipment for receiving stations will be considered under the following heads:

- (1) *General Features*
  - (a) Type of Station
  - (b) Type of Transformer
  - (c) Main Connections
- (2) *Necessary Equipment*
  - (a) Switchboards
  - (b) Circuit-Breakers
  - (c) Disconnecting Switches
  - (d) Protective Devices
  - (e) Bus Bars and Wiring
  - (f) Auxiliary Apparatus
- (3) *Present Design*
  - (a) Switching Stations without Transformers
  - (b) Receiving Stations with Transformers.

*Type of Station*—This paper deals with receiving stations operated from transmission lines of 22,000 volts and upward, with their equipment of transformers, switching devices, protective apparatus, and so forth. To secure the most suitable arrangement of a receiving station it is essential that the building be designed for the apparatus that it will contain, instead of attempting to arrange the equipment in a building already erected. It is the purpose of this paper to point out the main features of the apparatus required in receiving stations, with particular reference to such points as influence the design of the building.

*Type of Transformers*—Transformers may be divided into types determined by the means adopted for dissipating the heat developed in operation. These means may be divided into natural air-cooling, artificial air-cooling, natural oil-cooling, and artificial oil-cooling, and these determine the main features of the transformer.

Natural air-cooling depends on the conduction of heat through the air from the transformer to its case, where it is radiated to the surrounding air, and it has been found impracticable to build such transformers in large sizes.

Artificial air-cooling is obtained by forcing a blast of air through the iron and the coils of a transformer placed in a cast-iron housing, and ordinarily located over an air chamber where a pressure of one-half to one and one-half ounces is maintained by a blower, usually driven by a motor.

Owing to the difficulty of securing satisfactory insulation without the use of oil, air-blast transformers are not built for pressures above 33,000 volts, and are not recommended for more than 22,000 volts.

Natural oil-cooling takes place when a transformer is immersed in oil and provided with a case having sufficient radiating surface to dissipate the heat brought to it by the oil. Transformers of this type have numerous ducts extending through the opening in the iron from one end of the coil to the other, and similar ducts between the laminations permit a circulation of oil throughout the interior of the transformer.

Artificial oil-cooling is adopted for larger sizes, and two methods are in general use for cooling the oil, these being known as forced water and forced-oil circulation. In the former method one or more coils of seamless brass tubing are placed under the oil in the top of the transformer case near the walls of the tank, and water is circulated through these coils to remove the heat from the oil and to promote the circulation of the oil.

The circulation of oil in such transformers depends on the difference in weight between the hot and cold oil, and where the transformers are of large capacity this natural circulation is not vigorous enough to carry off the

heat developed, and it is necessary to resort to artificial circulation. This is accomplished by pumping the oil from the transformer case and circulating it through cooling coils placed in running water, a surface condenser or a blast of air.

For units of 5000 kilowatts and above, forced-oil circulation becomes advisable as giving more uniform cooling, lower maximum and lower average temperature rise. Three-phase transformers of 10,000 kilowatts for 120,000-volt service have been designed with forced-oil circulation, and even larger units can be built if required. The limit of size is largely a question of shipping facilities or of building up the transformer at destination.

The question of three-phase or single-phase transformers has been ably summed up by Mr. J. S. Peck in stating that three-phase transformers when compared with three single-phase units of the same total capacity, have the advantage of lower cost, higher efficiency, smaller floor space, less weight, simpler wiring, reduced freight and erection charges; while the main disadvantages are the greater cost of spare units and repairs. Allowing a spare unit in each case for one or two circuits, the single-phase units have the advantage in price of transformers, while for three or more circuits the three-phase units have the advantage.

The relative advantages of star and delta connections have been pretty thoroughly discussed at various times and seem to be reduced to these features. With delta connections one set of coils on a three-phase transformer or one of a bank of three single-phase transformers can be cut out of circuit, and the remaining two can then be connected in open delta and deliver 173/300 of the output with the same heating. With star connections the voltage on any one transformer is only 0.577, the amount between lines and a neutral point is available for grounding or other purposes.

The question of using star connections and a neutral grounded solidly or through a resistance is a mooted one, but the general practice, particularly for very high voltages, favors the star connection with neutral grounded through a resistance that

\*National Electric Light Association, 1908.

will limit the current that flows through a grounded line.

The use of small transformers operating from extremely high-tension lines is complicated by the fact that a power transformer cannot be economically built for a smaller capacity than about 0.5 kilowatt per thousand volts. As the voltage of the lines is raised, the size of transformer that can be economically built for operation at that voltage goes up, and it occasionally happens that a small consumer located near a transmission line of 66,000 volts, or higher, desires an amount of power less than that for which a transformer can be furnished suitable for that voltage.

On some of the larger transmission circuits, such as those of the Niagara, Lockport and Ontario Company's lines in New York, transformer stations are installed for lowering the line pressure from 60,000 to 11,000 volts, and various customers are then supplied at 11,000 volts.

*Main Connections*—For switching stations located along a transmission line the main connections are very simple, and, as a rule, simply allow for the opening up or connecting together of the various lines. For receiving stations with transformers the main connections will depend on the number and capacity of incoming lines, step-down transformers, outgoing feeders, local circuits, and so forth, and the proper arrangement of the bus bars, and so forth, is a matter of great importance. With one incoming line and a transformer circuit of the same capacity as the line, no high-tension bus bars are needed, as the line will connect through suitable switching devices direct to the transformer circuit.

If the one line feeds two or more transformer circuits, or two or more lines feed one transformer circuit, a single set of high-tension bus bars will be required. If there are two or more lines and two or more transformer circuits, a single set of bus bars is

With three or more lines, the best results can usually be obtained by having the transformer circuits of the same number and capacity as the lines, and arranging so that, normally, each line will feed its own transformer circuit, but in case of necessity can be

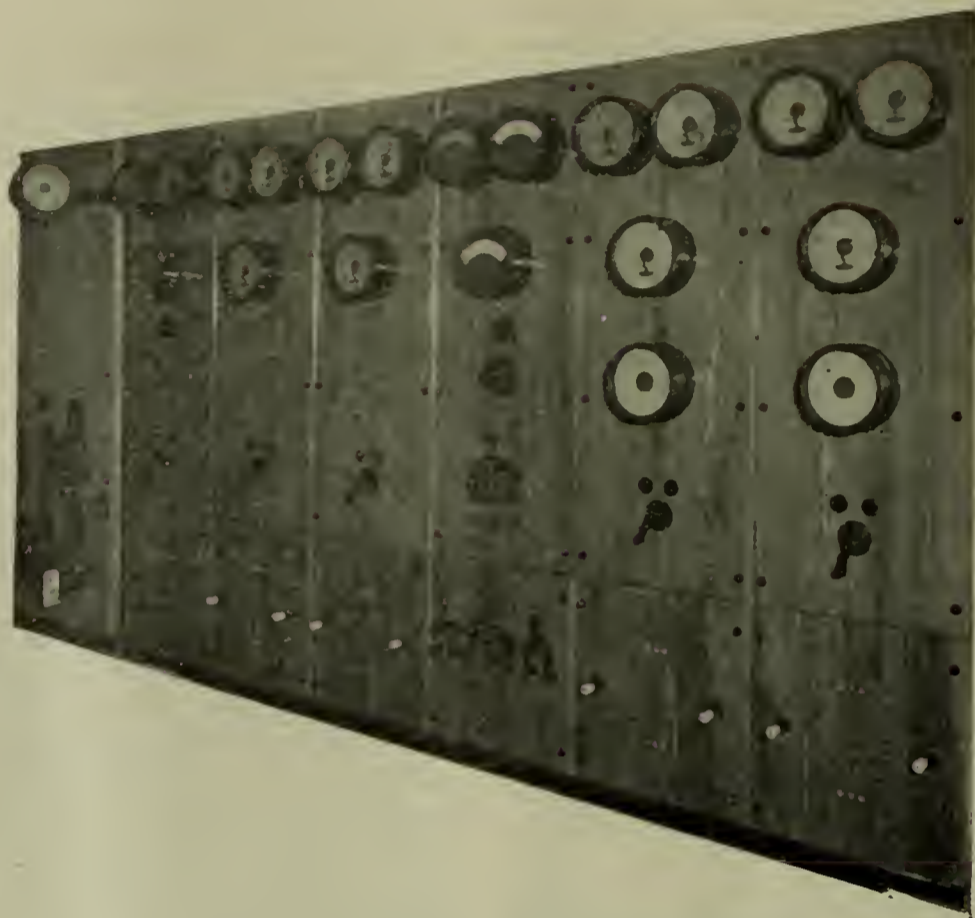

FIG. 1—SWITCHBOARD FOR RECEIVING STATION.

sometimes used; but, as trouble in this bus involves a complete shut-down of the station, a more flexible system is advisable. This flexibility is obtained by using a sectionalized bus, double bus, ring bus or relay bus, depending on the number of lines and circuits and the amount of flexibility desired.

connected to any transformer circuit.

*Switchboards*—In some of the switching and transformer stations described under division 3, various knife-switches, circuits, breakers, and so forth, are provided, and no switchboard, properly so called, is used. In other stations, particularly where elec-

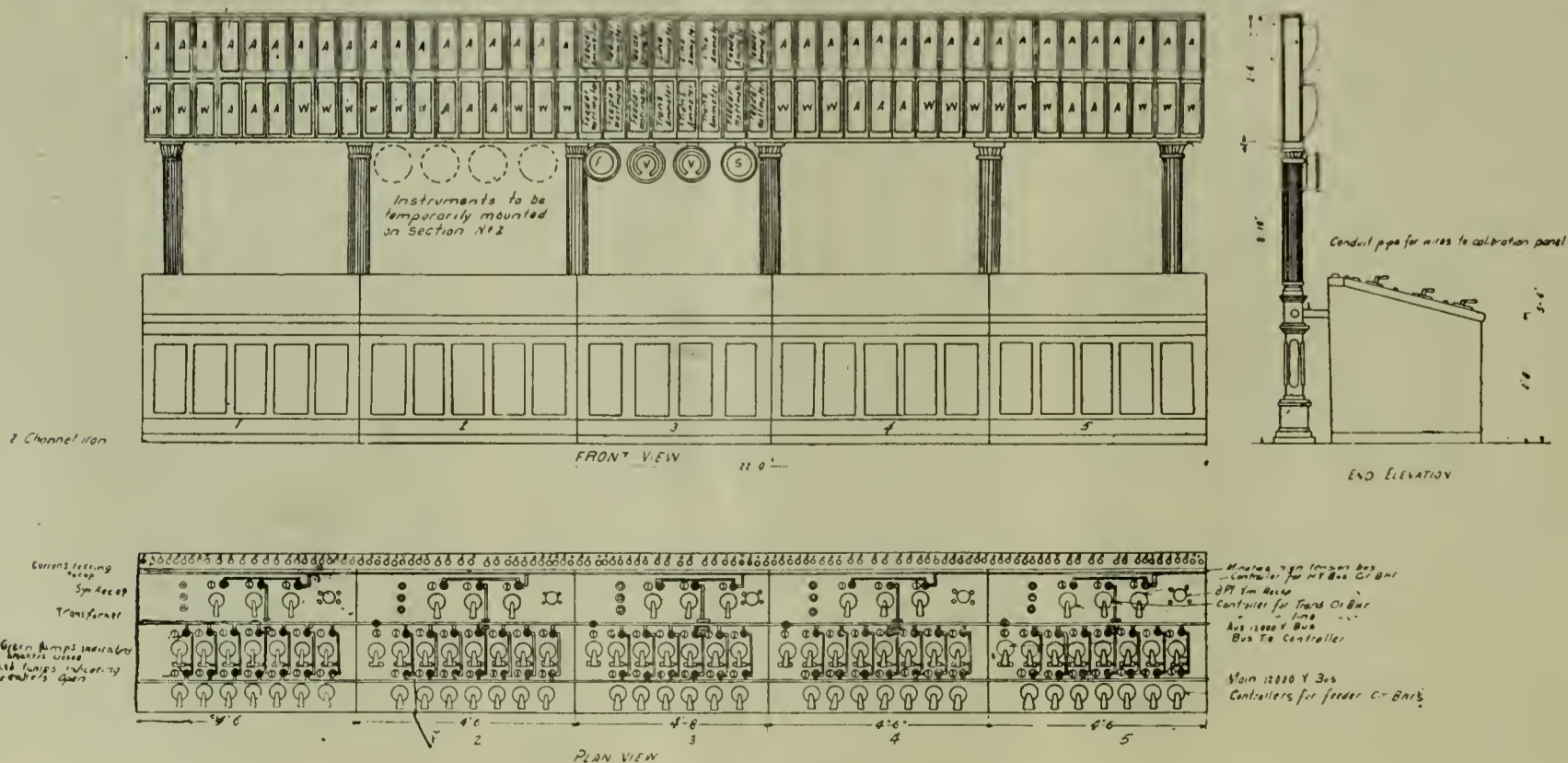

FIG. 2—CONTROL-DESK FOR RECEIVING STATION.



trically operated, oil circuit-breakers are used, some central point is usually chosen from which to control the station. This central point is ordinarily a switchboard on which are mounted the controlling devices, relays, and so forth, as well as various meters for the transformer and feeder circuits. These switchboards for receiving stations are usually made of the panel type, although occasionally a control-desk or bench-board is supplied.

The switchboard panels or the top slabs of the control-desk are ordinarily made of polished marble or slate with oil or marine finish. While polished marble has been used in many installations, marine-fish slate is growing in favor more and more, owing to its



FIG. 3—FUSED CIRCUIT BREAKER ON LINE INSULATOR.

being somewhat cheaper, and far easier to match and to keep in first-class condition.

The panel-boards used for receiving stations are simply modifications of standard switchboards, with panels for various line, transformer and feeder circuits, as well as a panel for the control of a small storage battery with the motor-generator set used for charging it. Fig. 1 shows a switchboard of this type supplied to the Niagara, Lockport and Ontario Company for use in its Gardenville substation for supplying power near Buffalo.

Where there are a large number of circuits to be controlled and a very compact arrangement is desired, a control-desk is often used, with the controllers mounted on the horizontal top of the desk and the instruments back of and above the desk in such a manner that the operator at the desk will face the switching and transformer room. While operating the controllers, and so forth, he can watch the meters or look under the instrument frame and over the top of the desk and watch the breakers, and so forth.

Fig. 2 shows a combined desk and instrument frame of this type, to be used ultimately to control five 9000-kw., 60,000-volt, three-phase incoming lines; five 9000-kw., 60,000-12,000-volt, three-phase step-down transformers, one 12,000-volt local service feeder and 29 12,000-volt distributing feeders. The original installation requires two of the five sections and will control two lines, two transformers and 12 distributing and one local service feeders.

The general connections of this station are rather clearly shown by means of the miniature bus-bar system on the top of the desk. The general scheme is to normally have each incoming transmission line feed its own three-phase transformer, and each transformer will normally operate on its own auxiliary bus, supplying power to about six 12,000-volt feeders.

The top of this control-desk consists of marine-finished slate slabs, while the front, back and sides are made of steel plates that are readily removable to permit access to the interior of the desk for getting at the connections, adjusting the controllers, and so forth.

*Circuit-Breakers*—While oil circuit-breakers are ordinarily employed to furnish automatic protection in high-voltage circuits, fused breakers of the type shown in Fig. 3 have been used on the circuits of the Niagara, Lockport and Ontario Power Company, to cut off the individual transformers, and fused breakers of this same general design have often been used in substations for single-phase railway propositions, as shown in Fig. 11.

Fig. 3 shows clearly the general arrangement of a fused circuit-breaker mounted on line insulators that are provided, suitable for the line voltage, and the design is such that the breaker arm can be arranged to open parallel to or at right angles with the plane of the support to which the base is bolted.

This fused circuit-breaker is essentially a single-pole device, and for special applications, such as cutting off individual transformers in the

manner used by the Niagara, Lockport and Ontario Power Company, or in transformer stations of single-phase railways, they have given great satisfaction. For the three-phase work it is usually advisable to have all three of the main circuits opened at the same time, and oil switches and circuit-breakers are used for this purpose.

The essential feature of an oil switch or breaker is that the circuit is ruptured under oil, and designs have been perfected for all classes of service, from the small-capacity, low-voltage apparatus to the 60,000-volt breakers used on the circuits of the Ontario Power Company, which are guaranteed to operate satisfactorily under any condition of overload or short-circuit that might exist in a plant of 200,000-kw. capacity. Breakers have been built and designed for circuits up to 132,000 volts, and higher limits can be reached if necessary.

Owing to the amount of power required for operating large oil circuit-breakers, motors or solenoids are usually employed, although practically

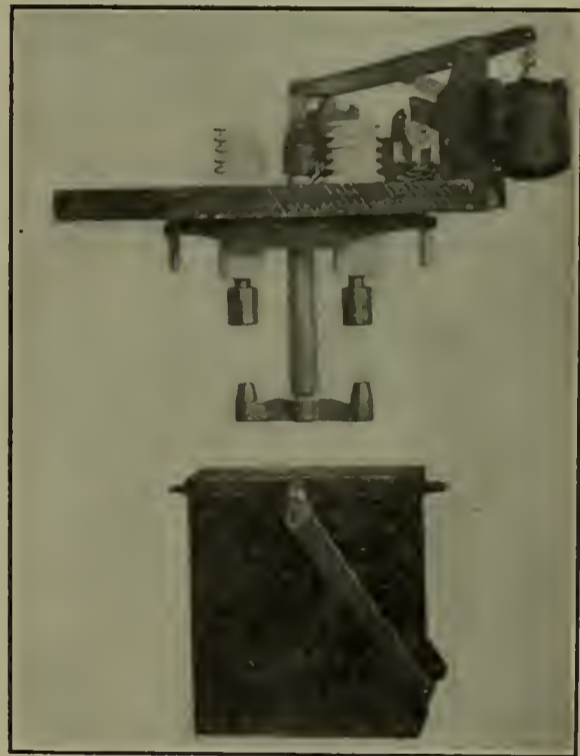

FIG. 4—6600-VOLT SMALL OIL CIRCUIT-BREAKER.

any type of solenoid-operated breaker can be arranged for hand operation.

Fig. 4 shows one pole of a breaker that is built in capacities up to 1200 amperes at 3500 volts and 100 amperes at 33,000 volts, with an ultimate breaking capacity for three units, forming a three-pole breaker of 10,400 kw. Each pole is intended to be placed in a separate fireproof compartment of masonry and is provided with its own closing and tripping solenoid, these being operated in multiple by a single controller. The design of the mechanism, contacts, and so forth, is clearly shown.



FIG. 5—6600-VOLT LARGE OIL CIRCUIT-BREAKER.

Fig. 5 shows a group of breakers that are built in capacities up to 3000 amperes at 3300 volts, and 300 amperes at 35,000 volts, and having an ultimate breaking capacity that has never been reached in any plant now installed or contemplated. Each pole of this breaker is enclosed in masonry structure, and all of the poles are operated by a single powerful mechanism.

The breakers shown in Figs. 4 and 5 are primarily designed for use in plants having the cellular construction for bus bars, wiring, and so forth, where it has been found of the utmost importance to isolate the bus bars, wiring, and so forth, in such a manner that leads of opposite polarity are separated by soapstone, concrete, brick or similar material, to prevent an arc starting in one place from being communicated to an adjacent conductor.

The amount of current available momentarily at the point of trouble in large stations operating at pressures of 12,000 volts or less is something enormous, and every precaution must be taken to prevent the spread of trouble. The problem of suitable distances and insulation is a simple one for such voltages.

For the high-tension circuits of 33,000 volts and above, the question of enclosing the bus bars and wiring becomes an entirely different proposition, for the reasons given under (2)-(e), "Bus Bars and Wiring," and it is highly desirable to use an open system of wiring with breakers particularly designed for that class of work.

Fig. 6 shows a breaker designed for 60,000-volt service with an ultimate breaking capacity of 20,000 kw., three-phase, while a modification of this breaker has been built for 88,000-volt service with an ultimate breaking ca-

capacity of 40,000 kw., three-phase. The hand-closing device furnished with the electrically operated breaker

is shown directly above the closing solenoid, but where electrical operation is not desired it is possible to place the handle on the switchboard and operate the breaker by means of a suitable bell-crank mechanism.

Fig. 7 shows a breaker built for 60,000-volt service and guaranteed to operate satisfactorily under any conditions of overload or short-circuit that might exist in a plant having 200,000 kw. in generating capacity. Modifications of this breaker can be arranged for high voltages.

The breakers shown in Figs. 6 and 7 are essentially top-connected, self-contained solenoid breakers with metal tanks, and these features are particularly valuable for the class of service for which they are intended.

The top-connected breaker is made with metal tank, and there is no trouble in securing oil-tight joints.

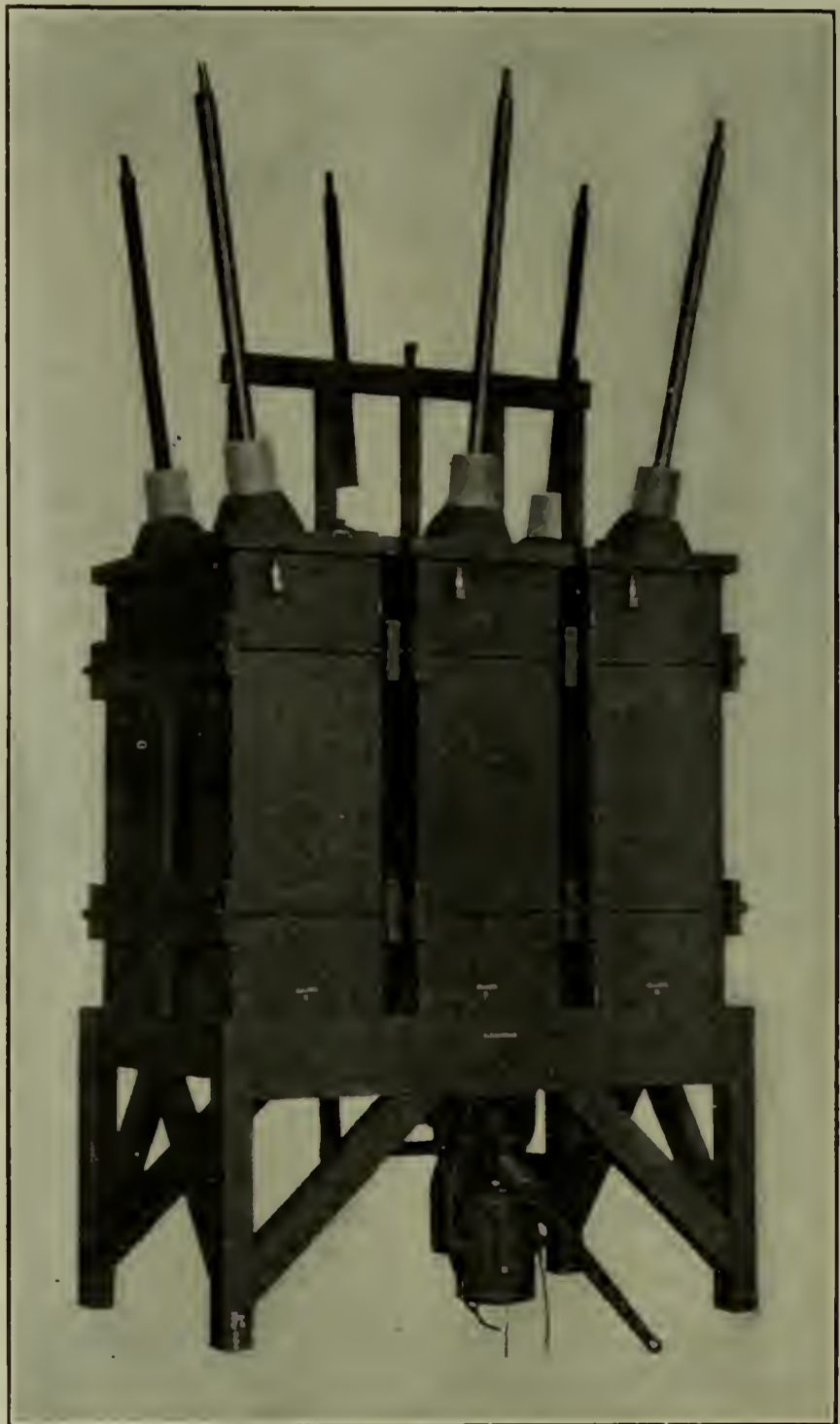

FIG. 6—60,000-VOLT SMALL OIL CIRCUIT-BREAKER.

The contacts are near the top of the tank, where the oil is apt to be in better condition than at the bottom,

and little trouble is found due to sediment, and so forth, settling on the contacts.

The top-connected, high-voltage breaker is provided with a single

overload, reverse current or other troubles.

The problem of suitable relays for use in connection with two or more incoming lines operating in multiple

was to provide reverse-current relays on the line circuits at the receiving station, these being operated when a damaged line drew power from the bus instead of delivering power to it. As overload protection was also needed, it usually happened that the overload relays on the good lines would act as quickly as the reverse-current relays on the damaged line and all of the breakers would trip out. This was remedied by providing time limit for the overload relays and making the reverse feature instantaneous.

Another trouble arises from the fact that in case of a serious short-circuit near the end of a transmission line, the heavy current flowing reduces the voltage and power-factor at the receiving station to such a low value that the reverse relay, whether built on the differential principle or the wattmeter principle, will not develop enough torque to act. A modification of the wattmeter type of relay has been built to give practically the same torque at low power-factor as at high, and to operate as a current relay even when the voltage drops to zero. Inverse time element features have been introduced to exercise a selective influence and to trip out the circuit in trouble without interrupting the other circuits.

The wattmeter type of relay, if set to a sufficiently delicate point to act on low voltage with sufficient torque on the contacts, is liable to trip out, due to vibration or mechanical shocks or to instantaneous surges, and no inverse time element feature can be



FIG. 7—60,000-VOLT LARGE OIL CIRCUIT-BREAKER.

direct-pull solenoid, located near the floor where the station attendant can readily inspect the mechanism, which in case of trouble will tend to fall open rather than close.

The top-connected breaker has all of the live metal parts submerged in oil, with the tanks, framework, mechanism, and so forth, thoroughly grounded and the breaker entirely self-contained, while with breakers having the terminals at the bottom of the pots, and the plunger rods that go into the top of the tanks exposed, a masonry structure is necessary.

The top-connected breaker can be built suitably for outdoor service in the manner shown in Fig. 8, which shows the outline and overall dimensions of a hand-operated breaker for use on a 110,000-volt circuit for outdoor service. Particular precautions have been taken for rendering the operating mechanism, terminal bushings, and so forth, impervious to severe weather conditions.

In order to furnish automatic protection to alternating-current circuits, relays of various types are used for closing the tripping circuits of the oil breakers. These relays can be made to operate instantaneously or with a time limit, either adjustable or inverse, and to give protection against

is an extremely difficult one. An overload, ground or short-circuit on one line will draw current from all of the

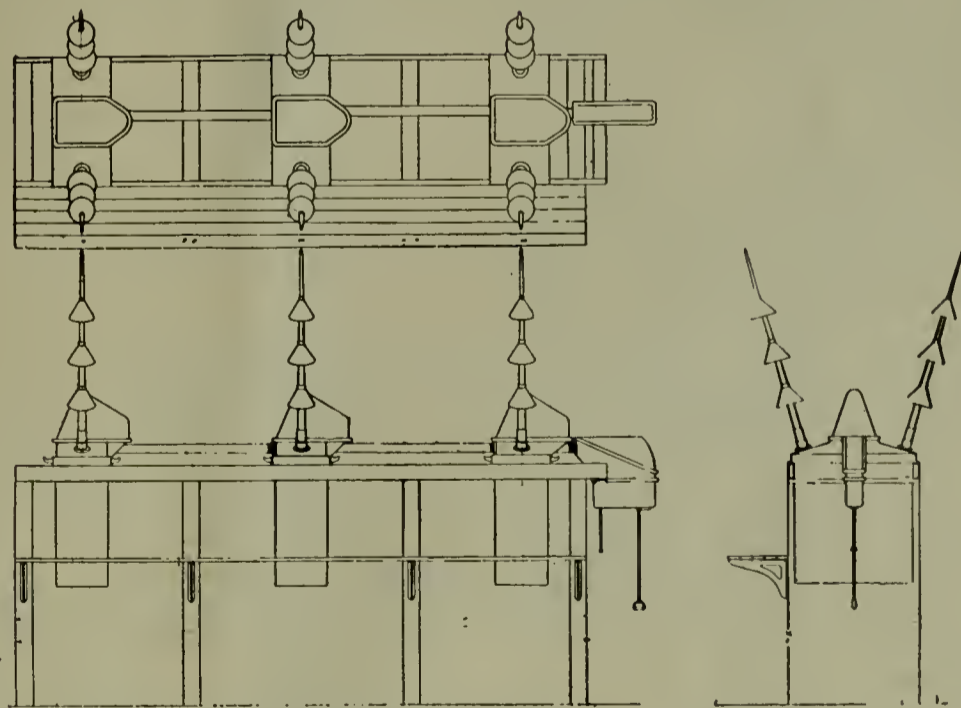

FIG. 8—110,000-VOLT OUTDOOR-TYPE OIL CIRCUIT-BREAKER.

lines through the receiving-station bus bars, and is apt to trip out all of the breakers and shut down the entire station unless relays are provided that will cut out the damaged line without affecting the others.

The first solution of this problem

worked in. The contacts have the duty of closing the trip circuit and, due to inherently low torque necessary to secure sensitiveness, they are liable to "freeze" and to have other mechanical troubles. A device known as the selective watt relay has been developed

for selecting between reverse and overload. This relay is of the "normally closed type" and is connected in series with the overload and reverse-current relay in the tripping circuit of



FIG. 9—88,000-VOLT OIL-IMMERSED CHOKE-COIL.

the breaker. The smallest flow of energy in the normal direction opens the contact of the selective watt relay, rendering the other relay inoperative. If a reversal equivalent to one per cent. occurs, the contact of the selective watt relay closes and the main relay can trip out the breaker. Owing to the time limit feature of the main relay, sudden surges will not trip out the breaker.

If overload protection is also desired, this can also be obtained by having independent closing contacts on the wattmeter relay; those on the overload side connecting direct to the tripping circuit of the breaker, while those on the reverse side connect through the contacts of the selective watt relay. The wattmeter relay can, of course, be provided with time-limit action.

**Protective Devices**—For high-tension circuits, choke-coils and lightning arresters are provided, to furnish protection against lightning and static disturbances of various kinds.

Choke-coils for such circuits are usually made in the form of a flat spiral for circuits up to about 25,000 volts, while for high voltages either the oil-immersed type or the open helical type can be supplied. As a rule the strain developed across adjacent turns of a choke-coil in a high-tension circuit is so great that when the coil performs the function normally expected of it, oil insulation

seems to be necessary to obtain the best results.

Fig. 9 shows an oil-immersed choke-coil for use on an 88,000-volt transmission circuit, where the lightning conditions are particularly severe and where the maximum amount of protection possible was desired, owing to the importance of the circuits to be protected.

Lightning arresters for these receiving stations are made of the low-equivalent multi-gap or of the electrolytic type, and as these have been often discussed and described there is no necessity of taking them up in this place. The electrolytic type of arrester seems to be growing in favor, largely due to the fact that it is suitable for outdoor service.

**Bus Bars and Wiring**—Practically all large receiving stations enclose the low tension secondary wiring if, between the limits of 500 and 13,200 volts, owing to the enormous momentary amount of current available under

ducting material getting across the bus bars.

For voltages of 33,000 and above fireproof barriers and cellular con-



FIG. 10—60,000-VOLT DISCONNECTING SWITCH.

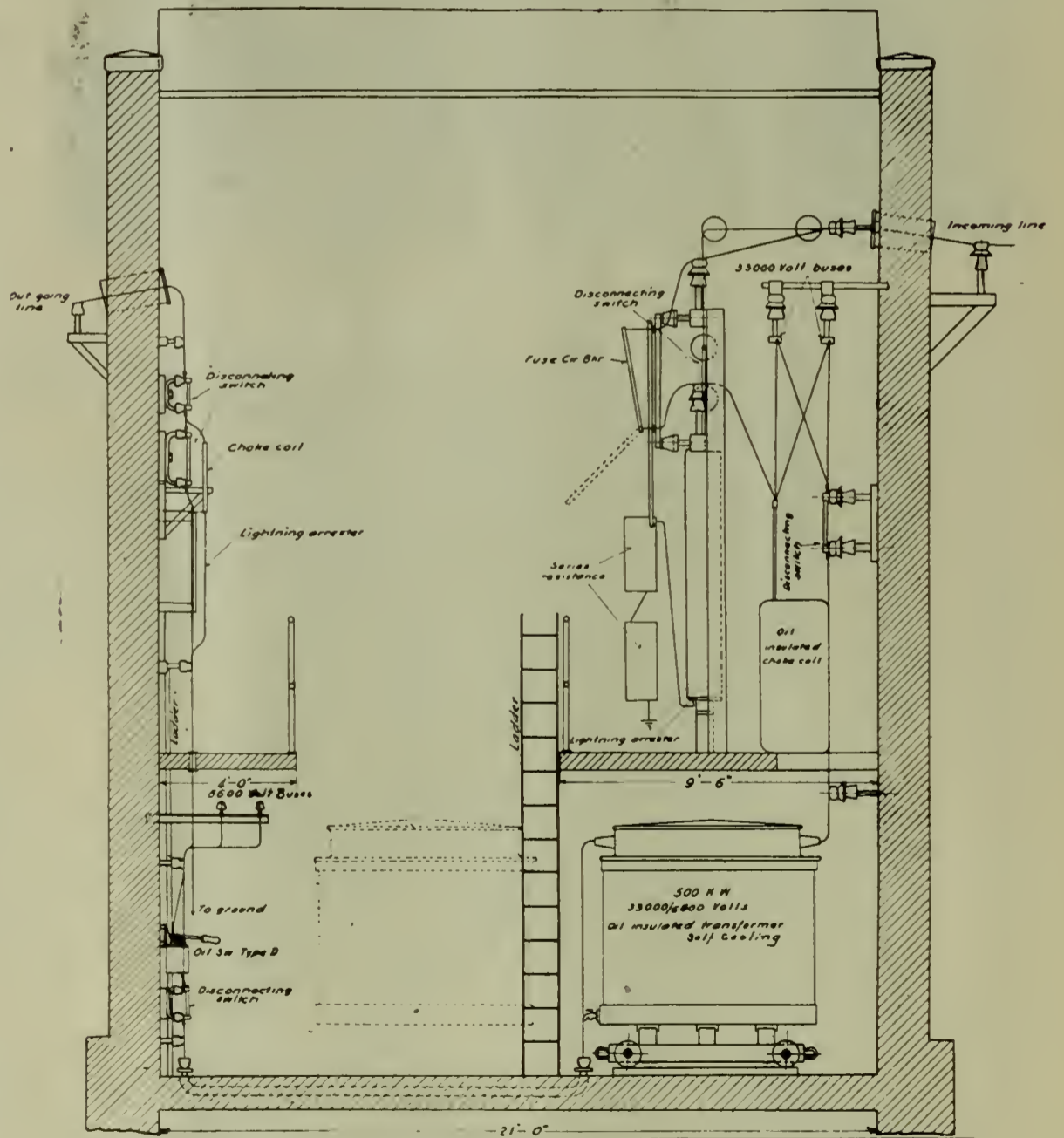

FIG. 11—33,000-VOLT SINGLE-PHASE TRANSFORMING STATION.

short-circuit conditions with the disastrous arcs resulting. This provides protection to the operator and security against breakdown due to some con-

struction are unnecessary, as the violence of the arc and the destructive effects of a short-circuit depend on the amount of current available at the

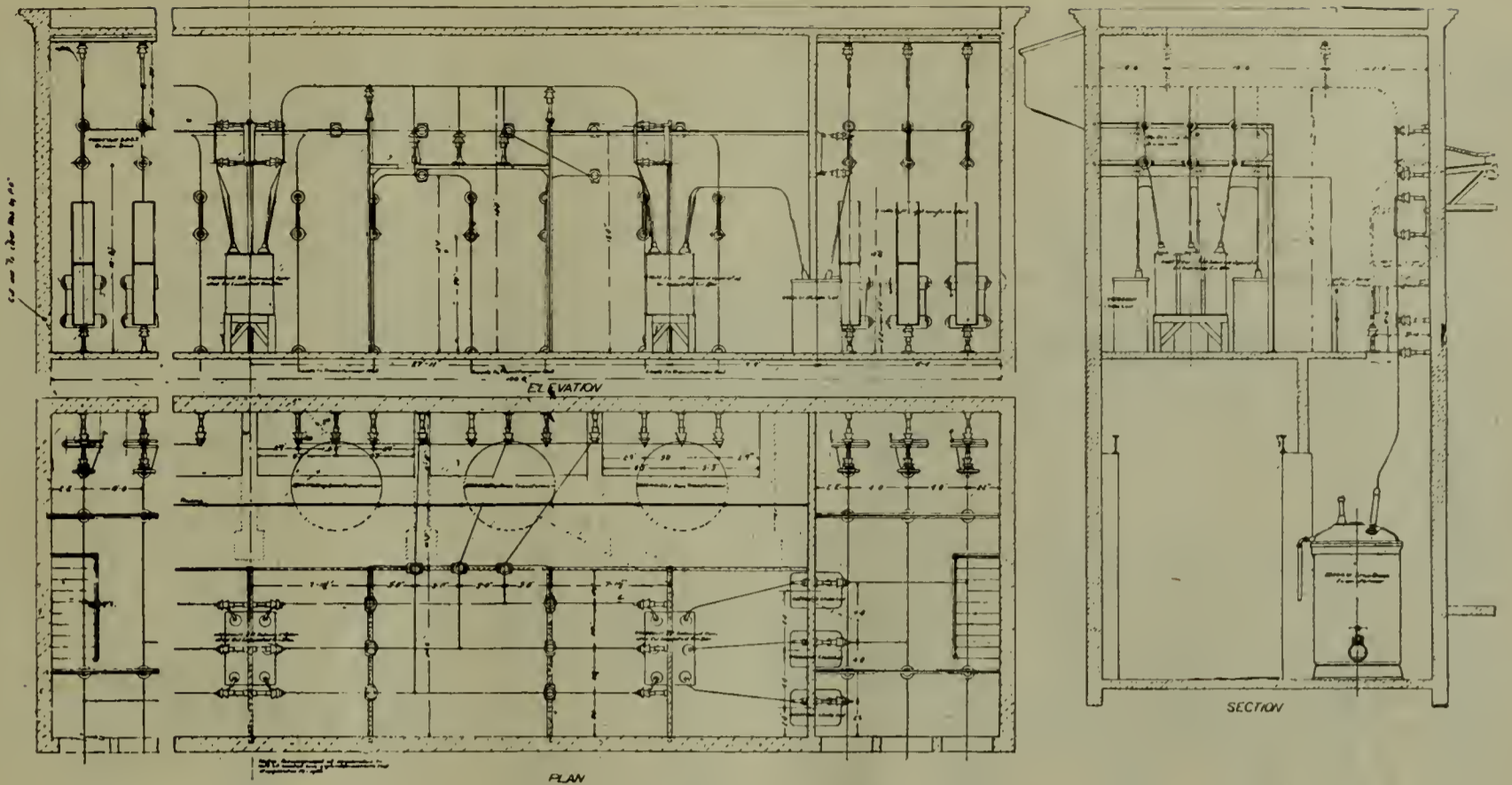

FIG. 12—44,000-VOLT TRANSFORMER STATION.

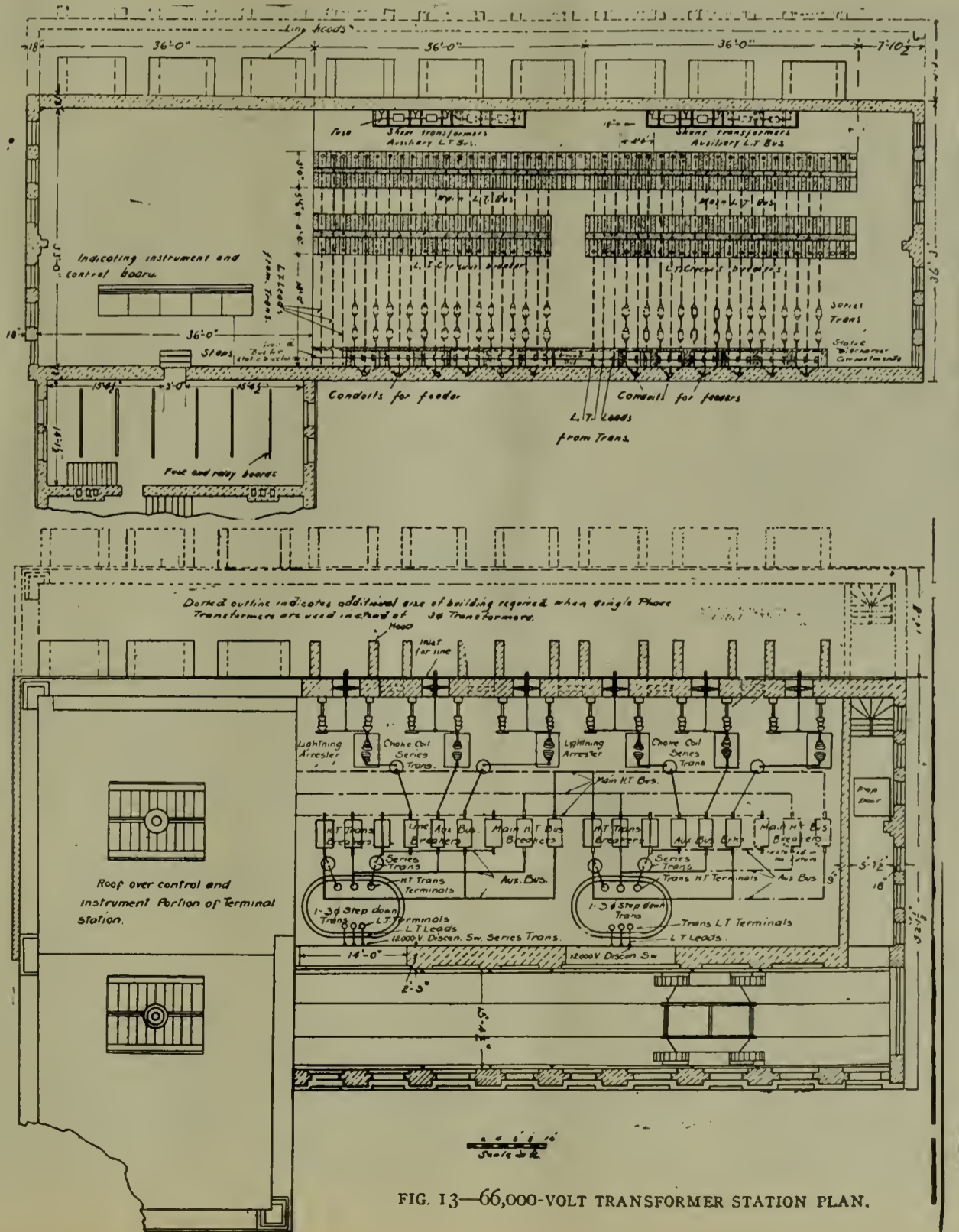

FIG. 13—66,000-VOLT TRANSFORMER STATION PLAN.

point of short-circuit, or for the same amount of power are inversely proportional to the voltage.

Fireproof barriers offer a more or less perfect ground for high-voltage

done only after power is cut off from the circuit. Where branch lines run off from the main lines, fuses are sometimes used, these being made of a sufficient length of fine copper or

tension and on the low-tension side. In the incoming-line circuit are two fused type circuit-breakers to furnish the automatic protection, and two oil-insulated choke-coils with low-equiva-

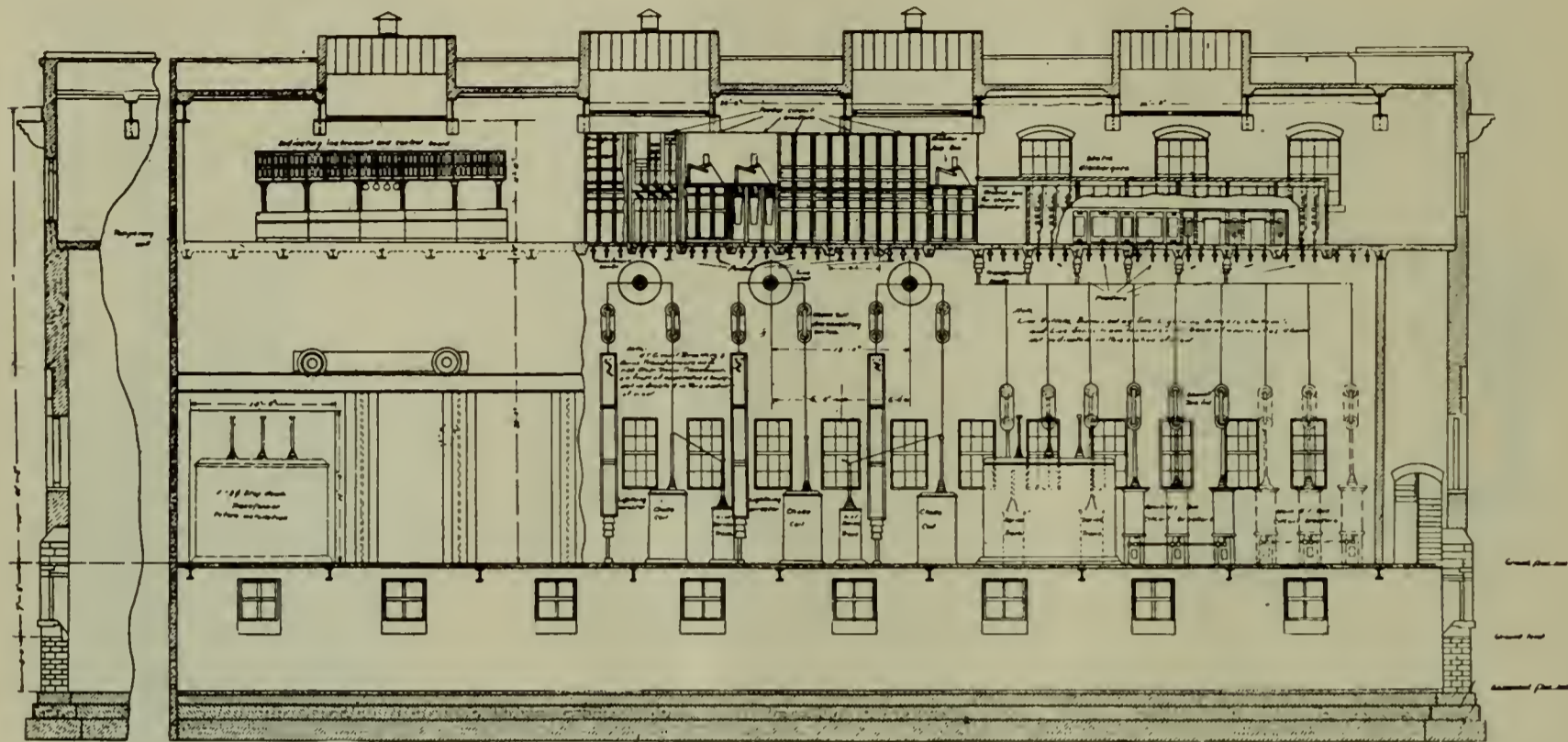

FIG. 14—66,000-VOLT TRANSFORMER STATION ELEVATION.

circuits, and the higher the voltage the more perfect the ground. With barriers the striking distance to ground has been reduced 50 per cent. or more over what could be obtained with open wiring in the same space.

Enclosed high-tension wiring, recommended by certain engineers, requires a more expensive building and makes the inspection and repair of bus bars, wiring, disconnecting switches, and so forth, far more difficult. This increased difficulty of inspection prevents incipient trouble being noticed so readily.

*Auxiliary Apparatus*—In receiving stations such as form the subject of this paper the main circuits are all alternating, and as direct current is usually required for the oil circuit-breakers, and so forth, it is necessary to install a mercury rectifier or a direct-current generator driven by an alternating-current motor. Usually a small 125-volt storage battery of from 40 to 100 ampere-hours' capacity is provided to insure a constant source of direct current, and this is charged by the rectifier or motor-driven generator.

*Switching Stations without Transformers*—Such stations are used for sectionalizing transmission lines or for providing branch circuits from the main lines. As a rule, these consist simply of knife-type disconnecting switches, like Fig. 10, mounted on the towers or poles, and all switching is

aluminum wire to insure the opening of the circuits.

A typical example of station tapped in on a transmission line is shown in Fig. 11, which illustrates the general arrangement of a single-phase trans-

ferent lightning arresters and disconnecting switches.

Fig. 12 shows the plan view and elevation of the top floor, as well as a section through the top and bottom floor, of the 44,000-volt receiving sta-

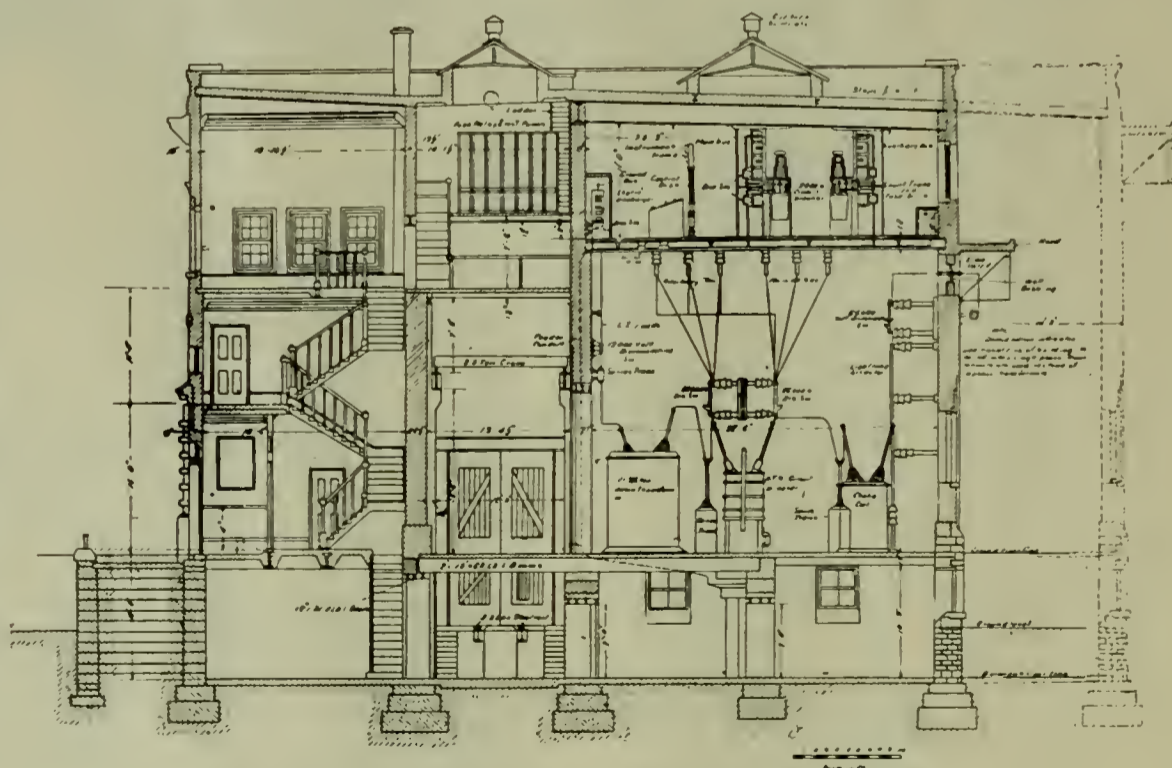

FIG. 15—66,000-VOLT TRANSFORMER STATION, SECTION.

former station for the Chicago, Lake Shore and South Bend Railway Company. In this station there are three 500-kw., 33,000-6600-volt, oil-insulated, self-cooling transformers, connected in multiple both on the high-

tion of the Provincial Light, Heat and Power Company, of Montreal. This station takes care of two 44,000-volt incoming lines and two banks, each of three 2500-kw. step-down transformers, delta-connected high-

tension and low-tension. Normally, each transmission line feeds its own bank of transformers, any one of which can be cut out of circuit by means of 44,000-volt disconnecting switches mounted on the wall. By means of the oil circuit-breakers in each incoming line and the tie-breaker, either or both lines can feed either or both banks of transformers. Each incoming line is provided with three oil-immersed choke-coils and three low-equivalent lightning arresters with disconnecting switches.

Fig. 13 shows the plan view, Fig. 14 the elevation and Fig. 15 the section of terminal station that will ultimately control five 9000-kw., 60,000-volt incoming lines; five 9000-kw., three-phase step-down transformers; one 12,000-volt local-service feeder, and 29 12,000-volt distributing feeders. This is the station for which the control-desk shown in Fig. 2 will be

used, and approximately two-fifths of the ultimate installation will be put in at first. The dotted lines appearing on Figs. 13 and 15 show the additional space required for the installation of three single-phase transformers in place of each three-phase transformer.

Fig. 13 shows the plan-view location of the apparatus in the low-tension and high-tension circuits. One part of the plan view shows the upper floor and locates the low-tension breakers, control-desk, terminal panels, and so forth; another portion shows the lower floor with the high-tension breakers, choke-coils, lightning arresters, and so forth.

Fig. 14 shows the relative location of the step-down transformers, high-tension and low-tension circuit-breakers, bus bars, disconnecting switches, and so forth. This elevation is taken in such a manner that one portion

shows the 12,000-volt circuit-breakers, bus bars, connections, and so forth, while the other portions show the control-desk, and so forth. One part of the high-tension compartment shows the oil circuit-breakers and step-down transformers, while another portion shows the out-going lines; choke-coils, lightning arresters, and so forth.

Fig. 15 shows the sectional view of the station, locating the transformers, low-tension and high-tension oil circuit-breakers, control-desk, relay panels, and so forth. As may be noted, all of the high-tension apparatus, bus bars, wiring, and so forth, have been located on the main floor, and can be readily inspected without danger, and without having to visit several floors and remove a large number of doors. The low-tension breakers, bus bars, and so forth, are placed on the second floor, with the control-desk, instrument and relay panels, and so forth.

## Distribution in Suburban Districts

GEORGE H. LUKES

THE four-wire, three-phase system seems to have many advantages over other systems for suburban work.\* In this system the generator or transformers are Y-connected, the neutral being brought out and connected to a grounded fourth bus bar. The voltage between any phase wire and neutral is 2200 and between any two of the phase wires is 3800. Single-phase feeders are supplied from neutral and any phase being controlled by double-throw switches for balancing. Districts in which the load consists of both power and lighting are supplied from four-wire feeders, which run to centers of distribution from which radiate two-wire, single-phase mains for lighting, and three or four-wire, three-phase mains for power. If the load is mostly lighting the feeder may be three-wire, consisting of two-phase wires and neutral. In this case but one feeder regulator is needed, the extra phase wire being used for power only. Power in large units is supplied from three standard transformers, connected with primaries in star and secondaries in delta. Small three-phase power installations may be supplied from two-phase wires and neutral by two standard transformers in open delta. This system requires but one-third the copper necessary for single-phase or four-wire, two-phase at 2200 volts and about 44 per cent. of that required for a three-wire, three-phase system operating at 2200 volts under equivalent conditions. Mention has been made above of the necessity of

supplying as large an area as possible from each substation in order to keep down substation investment and maintenance. The four-wire, three-phase system is a means to this end. Its use makes it possible to distribute over a much larger area than can be reached economically by either the two-phase system or the three-wire, three-phase system, and this advantage is secured without the necessity of departing from the use of standard transformers. A factory power installation of 200 or 300 horse power at a distance of four or five miles from the station or substation presents no difficulties with this system, and the ability to take on business of this kind without excessive investment may be of considerable pecuniary benefit to the company.

Careful attention must be given to the matter of balancing the load on long three-wire secondaries. The number of lights connected to each side may be nearly equal, but tests often show loads largely out of balance. Periodical tests with a portable cable-testing current transformer and ammeter are necessary in order to avoid trouble from this source. Distribution at 220-440 volts has been resorted to by some suburban companies in order to be able to group a larger number of customers on one transformer and thus reduce distribution losses. This scheme has been somewhat burdensome on the customers, on account of the low efficiency of the 220-volt lamps, and has become even more unsatisfactory since the metallic-filament lamps have been

placed upon the market, as they are not made at all in the higher voltages. No greater boon to the suburban companies could be devised than the development of a high-efficiency 220-volt lamp, as the large investment in small transformers and consequent high distribution losses are serious obstacles to the extension of business in scattered districts.

### ARRANGEMENT OF WIRES ON POLES.

It is very desirable that circuits of different kinds be systematically arranged on the cross-arms. This makes it easier to handle line trouble in emergency and also facilitates the keeping of records. Ideas differ as to the best arrangement, and no uniform plan can be given that will apply to all conditions. In general the following rules apply:

Wires carrying the highest voltage should be on the upper cross-arms. Feeders and circuits to remote points should also be on the upper cross-arms, where they will not be disturbed. Primaries and street-lighting circuits for local use should be on the lower arms, where taps and transformer connections can be conveniently made. Secondary wires should be on the lowest arm by themselves. The necessity for the last rule has been questioned, but if adhered to it undoubtedly makes service and trouble-work safer, as it is sometimes difficult to distinguish between a three-phase primary and a three-wire secondary.

The additional safety to life secured secondaries is now fully appreciated by grounding the neutral of three-wire

\*National Electric Light Association, 1908.

by everyone and is recommended by the Underwriters. Various methods of grounding the neutral have been used in the past. The most practical method is to drive a galvanized gas pipe into the earth at the foot of the pole. The ground wire is brought down the pole in wooden molding and connected to the ground pipe, which is also sometimes protected above the surface of the ground by a larger wooden molding. The problem of making a permanent joint between the ground wire and pipe has been a bothersome one. Soldered joints and plugs have been tried with indifferent success. The ground cap devised by the engineers of the Commonwealth-Edison Company seems to have solved the problem. This consists of a malleable galvanized-iron cap provided with an internal groove into which the No. 6 ground wire is wedged between the inside of the cap and the ground pipe. The cap protects the end of the pipe while it is being driven and makes a rigid contact. Experience indicates that reliance should not be placed on a single ground, and a safe plan is to install at least two grounds on each secondary. It is possible that sometime in the future the practice will become standard of grounding the neutral wire of each house service to the water-piping of the house.

#### QUESTIONS AND ANSWERS

Question.—*We are going to buy a motor of 30 h.p., 3 ph., 60 cycles, 220 volts, and the power company is forcing us to purchase transformers to step down the line voltage to our working pressure. Will three 10-h.p. (or say 7.5-kw.) transformers, or the equivalent of two 15-h.p. transformers, be satisfactory to use?*

Answer.—No. Use one kilowatt in transformer capacity for every horse power in the motor. This is to give you ample current at starting when the power factor is low. In very small sizes, from about five horse power down, 1.5 kw. in transformers should be used for each horse power in the motors.

Question.—*We have never had station arresters on our lines, but some have been purchased for me to cut in. Should they be put on the line between the choke coil and the outside, or between the coil and the generator?*

Answer.—The proper connection is as follows:

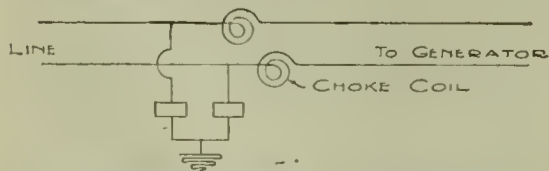

The object of this arrangement is to throw back on the arresters, for

ground discharge, any excessive voltage which may reach the choke coils from outside sources.

Question.—*We have three exciters in one plant and two more are to be installed. Will this mean additional Tirrell regulators?*

Answer.—The manufacturers of the Tirrell regulator make them to take care of as many as 12 exciters by working certain changes on the relays. You will have to consult them to find out what method to follow in your particular case.

Question.—*The armature of our generator got into trouble recently, and when I disconnected some of the leads from the commutator I found underneath a lot of wires running around the armature. What could they have been for?*

Answer.—These were probably "equalizing connections." In any multipolar generator there will be a number of points of equal voltage for every pair of poles. It is practically impossible to get every pole exactly like every pole, so that one may be a better magnet than another. Accordingly, the armature might generate 110.5 under one pair of poles and 110 under another. As the armature resistance is low, this one-half volt would be accompanied by heavy amperage. This low voltage current would tend to circulate within the armature, causing excessive heating and sparking at the commutator. To overcome this, about every seventh bar of a commutator is connected to every other point of similar voltage by an equalizing connection.

Question.—*I have had to dig out the insulation between some of the bars on the commutator of our machine. This causes continual trouble due to copper dust and compound accumulating, and getting into the crevices. How can I overcome it?*

Answer.—Go into any paint store or chemical shop and buy some "waterglass," clean out the crevices and fill with the above.

Question.—*We are soon to start up some high-tension transformers. The manufacturers have sent instructions to dry them out thoroughly before starting up for the first time. As there is no standard of dryness, how am I to know when they are thoroughly dry?*

Answer.—There is no way of telling when a transformer is thoroughly dry. All you can do is to take insulation resistance. As this would be lower with the transformer hot than cold, you should take it as nearly as possible

to probable operating temperature. By referring to the standardization rules of the A. I. E. E., you can find out about what resistance you should look for.

Question.—*How can I detect the presence of water in my transformer oil; also acid?*

Answer.—Roast some blue stone until the water in it has been driven out and it has turned white. If the addition of some transformer oil will restore the blue color, it means that water is in the oil. Acid is most easily detected by using blue litmus paper, which turns red under the pressure of acid.

#### The Western Electric Company Enters the Steam Turbine Field

The Western Electric Company has recently closed a deal whereby it will manufacture and sell the Rateau turbine in connection with its generators.

The turbines are very similar to the Rateau type as built in Europe, except that the construction is a little heavier and stronger to meet American conditions. They are of the impulse type and divided into a large number of stages. The wheels are turned out of a solid steel plate, the cross-section of which gradually increases toward the center. The buckets are made of a special alloy of great mechanical strength and rust-resisting properties. The buckets are secured independently of each other by means of special rivets of great mechanical strength, and are spaced at the periphery by a spacing ring, which serves to maintain an accurate spacing of the buckets, as well as to act as a baffle for improper currents of steam. The turbines have fixed diaphragms which extend to the shaft between the wheels and form a cell in which each wheel operates.

The governor is of the spring-balance fly-ball type, operating in connection with a dash-pot, and is located in a cylindrical casing on the turbine bearing. The governor regulates the speed by means of a double-beat type valve, which throttles the steam.

The bearings are of the most simple construction, being practically the same as those of the ordinary ring-oiled dynamo, except that they have water jackets to maintain the temperature at the desired value. The turbine being of the impulse type, there is practically no end thrust, and only a few thrust collars are necessary to locate the shaft, these being placed at one end of the governor bearing.

The Wisconsin Steel Company already has in operation one of these turbines, operating on exhaust steam from the blooming engines and driving a direct-current generator.



# The National Electric Light Convention

THE annual convention of the National Electric Light Association was held at the Auditorium Hotel, Chicago, on May 19th, 20th, 21st and 22d. The program was as follows:

Tuesday, May 19th, Opening Session, 10 o'clock.—President's address; announcements by the secretary; report of committee on progress, Mr. T. Commerford Martin, New York; "Distribution in Suburban Districts," Mr. George H. Lukes, Chicago, Ill.; "Tape," Mr. Paul Lüpke, Trenton, N. J.; report of committee on grounding secondaries, Mr. W. H. Blood, Jr., chairman, Boston, Mass.; "Series Incandescent Lighting with

Session, 10 o'clock.—Report of committee on gas engines, Mr. W. C. L. Eglin, chairman, Philadelphia, Pa.; "Low-Pressure Steam Turbines," Mr. John W. Kirkland, Schenectady, N. Y.; report of committee on meters, Mr. L. A. Ferguson, chairman, Chicago, Ill.; "Receiving Stations Operated from High-Tension Lines," Mr. S. Q. Hayes, Pittsburg, Pa.; report of committee on organization possibilities, Mr. Henry L. Doherty, New York City; special meeting, Banquet Hall, sixth floor. Parallel Session, 10.15 o'clock.—"Uniform Accounting and Its Details," open to all accountants and others interested; Mr. H. M. Edwards, chairman committee on uni-

guson, past president, Chicago, Ill. 2. Preparation for a Campaign. (a) Field Work and Other Essentials; (b) Analysis of Customers' Accounts; (c) Proportion of Lamp Equivalent Lost to Lamps Connected—Showing Percentage in Cities of Varied Population; (d) Policy of Handling Complaints; (e) Policy of Handling Collections. Editor, Mr. H. J. Gille, Minneapolis, Minn. 3. The Contract Agent and the Representative. (a) The Contract Agent—His Possibilities; (b) The District Representative—His Possibilities; (c) The Special Representative: 1, The Sign Expert; 2, The Power Expert; 3, The Woman Representative; (d) Solicitors' Meet-



NATIONAL ELECTRIC LIGHT ASSOCIATION IN CONVENTION AT AUDITORIUM HOTEL, CHICAGO.

Tungsten Lamps," Mr. P. D. Wagoner, Schenectady, N. Y. Afternoon Session, 2.30 o'clock.—"Observations on the Precision of Different Types of Photometer," Prof. A. E. Kennelly and Mr. S. E. Whiting, Harvard University; "Power-Load Development for Central Stations of Moderate Size; Some Unappreciated Possibilities," Mr. Charles Robbins and Mr. J. R. Bibbins, Pittsburg, Pa.; "The Small Station and its Economical Operation," Mr. J. T. Whittlesey, Newark, N. J., and Mr. Paul Spencer, Philadelphia, Pa.

Wednesday, May 20th, Morning

form accounting, in the chair. Evening Session, 8 o'clock.—Executive session; report of secretary and treasurer and executive committee; report of insurance expert, Mr. W. H. Blood, Jr., Boston, Mass.; report of committee on public policy, Mr. Arthur Williams, chairman, New York City; "The Status and Commercial Possibilities of High-Efficiency Lamps" and Discussion, Mr. W. W. Freeman, Brooklyn, N. Y.

Thursday, May 21st.—Commercial Day.—I. Address—"Relationship Between the Engineering and Commercial Departments," Mr. Louis A. Fer-

ings—Their Objects. Editor, Mr. V. A. Henderson, Memphis, Tenn. 4. The Display Room. (a) Appointments and Methods; (b) Value of Special Demonstrations; (c) Value of Electrical and Food-Show Exhibits. Editor, Mr. L. G. Mathes, Dubuque, Iowa. 5. Advertising. (a) What is Being Done; (b) Why? (c) Results. Editor, Mr. Charles A. Parker, Detroit, Mich. 6. Publicity. (a) Methods to Create Proper Public Sentiment; (b) Dormant Publicity Opportunities of Lighting Companies. Editor, Mr. Percy Ingalls, Newark, N. J. 7. Creating Demand for Elec-

tricity. (a) The Creative Principle; (b) Notable Examples; (c) Stereopticon Talk upon Outline and Sign Lighting. Showing Progress in Large and Small Cities. Editor, Mr. Frank B. Rae, Jr., New York City. 8. Evolution of New-Business Building. (a) Examples of Central Stations that Have Continued Methods During Depression; (b) Strong Plea for Up-keep of Commercial Departments and Advertising; (c) Opportunities for Creating Business Along Existing Lines. Editor, Mr. George N. Tidd, Scranton, Pa. 9. The Electrical Contractor. Symposium; (a) What He is Doing to Assist in Creating Greater Demand for Electricity; (b) Specific examples. Editor, Mr. Joseph F. Becker, Jr., Brooklyn, N. Y. 10. "Co-operative Commercialism," Mr. J.

Among those present were the following: J. B. Adams, Waterbury Company, New York City; Godfrey H. Atkin, Electric Storage Battery Company, Chicago; Morgan Brooks, professor of electrical engineering, University of Illinois; W. J. Barr, president Guaranty Electric Heater Company, Cleveland; B. A. Behrend, chief electrical engineer Allis-Chalmers Company, Milwaukee, Wis.; Jacob Bunn, president Sangamo Electric Company, Springfield, Ill.; C. E. Brown, secretary Central Electric Company, Chicago; D. J. Burns, general sales manager Ward Leonard Electric Company, Bronxville, N. Y.; T. H. Brady, T. H. Brady Manufacturing Company, New Britain, Conn.; C. O. Baker, Baker & Company, New York City; Charles Blizard, third

president Dale Company, New York City; Avery P. Eckert, manager sales Duplex Metals Company, New York City; A. C. Garrison, president Columbia Incandescent Lamp Company, St. Louis; Rodman Gilder, publicity manager Crocker-Wheeler Company, Ampere, N. J.; F. H. Gale, in charge of advertising, General Electric Company, Schenectady, N. Y.; H. M. Hirschberg, president Excello Arc Lamp Company, New York City; F. E. Hunting, sales manager and treasurer Fort Wayne Electric Works, Fort Wayne, Ind.; E. H. Houghton, manager Bryan-Marsh Company, Chicago; Alexander Henderson, American Circular Loom Company, Boston; W. S. Heger, assistant to the president, Allis-Chalmers Company, Milwaukee; W. H. Jacob, sales manager Triumph Electric Company, Cincinnati, Ohio; Basil G. Kodgbanoff, sales manager Benjamin Electric Manufacturing Company, Chicago; A. N. Fox, advertising manager Benjamin Electric Manufacturing Company, Chicago; B. C. Kenyon, president Diehl Manufacturing Company, Elizabethport, N. J.; V. R. Lansingh, chief engineer and general manager Holophane Company, New York City; R. C. Lamphier, secretary and manager Sangamo Electric Company, Springfield, Ill.; W. W. Low, president Electric Appliance Company, Chicago; W. A. Layman, vice-president and general manager Wagner Electric Manufacturing Company, St. Louis; R. K. Mickey, president Novelty Incandescent Lamp Company, Emporium, Pa.; George A. McKinlock, president Central Electric Company, Chicago; George T. Manson, general superintendent Okonite Company, Limited, New York City; Joseph E. Montague, general manager Buffalo & Niagara Falls Electric Light and Power Company, Niagara Falls, N. Y.; J. C. McQuiston, manager Westinghouse Companies' Publishing Department, Pittsburg; W. M. Matthews, treasurer W. N. Matthews & Brother, St. Louis; W. W. Merrill, secretary Chicago Fuse Wire and Manufacturing Company, Chicago; N. L. Norris, secretary and manager Banner Electric Company, Youngstown, Ohio; Frank S. Price, secretary Pettingell-Andrews Company, Boston; H. M. Post, advertising manager Western Electric Company, Chicago; George F. Porter, sales manager Atlantic Insulated Wire and Cable Company, New York City; A. H. Patterson, vice-president Phoenix Glass Company, New York City; J. W. Perry, manager electrical department, H. W. Johns-Manville Company, New York City; H. C. Rice, vice-president General Incandescent Lamp Company, Cleveland.



A VIEW OF THE EXHIBIT HALL ILLUMINATED BY TUNGSTEN LAMPS, WITH FILAMENTS BURNING AT ALL ANGLES.

Robert Crouse, Cleveland, Ohio. 11. "Illuminating Engineering as a Commercial Factor," illustrated, Mr. V. R. Lansingh, New York City. 12. Report of committee on solicitors' handbook prize award, Mr. John F. Gilchrist, chairman, Chicago, Ill. 13. Report of committee on co-operative electrical development, Mr. W. W. Freeman, chairman, Brooklyn, N. Y.

Friday, May 22d.—"Illuminating Engineering," Mr. W. D'A. Ryan, West Lynn, Mass.; Report of committee on protection from lightning and other static disturbances, Mr. R. S. Stewart, chairman, Detroit, Mich.; "The Value of Care and Maintenance of Meters," Mr. H. D. King, Hoboken, N. J.; "Some Experiments in Combustion," Mr. S. J. Lenher, New York; "Specifications for Construction on Joint Poles," Mr. Paul Spencer, Philadelphia, Pa.

vice-president Electric Storage Battery Company, Philadelphia; A. Benson, International Electric Meter Company, Chicago; C. E. Corrigan, vice-president National Metal Molding Company, Pittsburg; William Coale, treasurer and manager Sterling Electric Manufacturing Company, Warren, Ohio; Frank J. Coakley, Samson Cordage Works, Boston; Walter Cary, general manager Westinghouse Lamp Company, New York City; W. W. Cheney, Jr., president International Electric Meter Company, Chicago; C. A. Dubosch, manager Hugo Reisinger, New York City; A. J. DeCamp, manager Philadelphia Electric Company, Philadelphia; S. E. Doane, chief engineer National Electric Lamp Association, Cleveland; F. L. Driver, president and treasurer Driver-Harris Wire Company, Newark, N. J.; J. H. Dale,

FREE PUBLIC LIBRARY  
AUG 13 1908  
ST. JOSEPH, MO.

# THE ELECTRICAL AGE

Volume XXXIX. Number 7.  
\$1.00 a year; 15 cents a copy

New York, August, 1908

The Electrical Age Co.  
New York and London

ESTABLISHED 1883

Published monthly by The Electrical Age Co., 45 E. 42d Street, New York.

J. H. SMITH, Pres. C. A. HOPE, Sec. and Treas.

JOHN HAYS SMITH, Editor.

Telephone No. 6498 38th. Private branch exchange connecting all departments.

Cable Address—Revolvable, New York.

## SUBSCRIPTION RATES

United States and Mexico, \$1.00; Canada, \$1.50. To Other Countries, \$2.50

## NOTICE TO ADVERTISERS

Insertion of new advertisements or changes of copy cannot be guaranteed for the following issue if received later than the 15th of each month.

## LONDON OFFICES

Business and Editorial Departments, 33 Bedford Street  
Strand, W. C.

London Telephone, Post Office, 3807 Central. Private branch exchange. London Cable  
Address—Revolvable, London.

All remittances to London Office should be crossed London and County Banking Company.

## BRANCH OFFICES AND AGENCIES

Subscriptions may be sent to the following branch offices or agencies, where they will receive the same careful attention as at the home office in New York:

124, Queen St., Melbourne  
359, George St., Sydney  
61, Main St., Yokohama  
23, Esplanada Rd., Bombay

33, Loop St., Cape Town  
Unter den Linden, 5, Berlin  
Nevsky Prospect, St. Petersburg  
31, bis rue de Fauburg Montmartre, Paris

General Agents for United States and Canada: The American News Company

## The Development of the Regulating Converter

It is well known that a rotary converter maintains practically a definite and constant ratio between the electromotive force at the collector rings and the electromotive force at the commutator. In order to vary the electromotive force of the direct current it is therefore necessary to vary the electromotive force of the alternating current supplied to the machine. Various well-known methods are used for this purpose, such as a transformer with variable ratio, made by changing the number of turns in one of its windings. This requires a regulator with contact devices, which is in general objectionable, especially on large sizes, where the current is of considerable magnitude. Another form of regulator is the induction regulator, built somewhat similar to an induction motor; the secondary electromotive force delivered from the regulator depends upon relative position of primary and secondary. Consequently a change in the angular position of the secondary changes the electromotive force delivered. This is used for varying the electromotive force supplied to the rotary converter.

An induction regulator is a somewhat cumbersome piece of apparatus, and ordinarily requires artificial cooling.

Another method which is in use for automatic compounding is the choke coil, which is sometimes placed in the alternating-current conductors. This method of control requires a varying power factor, which is often objectionable.

## The Synchronous Regulating Converter

A new method of control, which has lately been introduced in connection

with a number of rotary converters in New York, employs an auxiliary alternator, mounted on the shaft of the rotary converter. This alternator has a number of stationary field poles, equal to the number of field poles of the rotary converter. The alternating-current conductors leading to the rotary converters are passed through the armature of the auxiliary alternator. The electromotive force induced in this auxiliary machine is under control of its field current. This electromotive force may, therefore, be made to increase that of the supply circuit, or it may be reversed by reversing the direction of the field current, in which case it will oppose the electromotive force of the supply circuit, and deliver to the rotary converter a reduced electromotive force. The principle involved is therefore quite elementary and simple. The apparatus is likewise of a simple type, and is quite easily operated.

The action is substantially the same as that of an ordinary booster in connection with the direct-current machine.

### John A. Roebling

The victories of the engineer over the forces and obstacles of nature are so recent in the world's history that people have not yet gotten the habit of regarding them as of equal importance to those of the soldier, the sailor and the statesmen.

It is therefore genuine pleasure to note that the good people of Trenton have erected a monument to the memory of John A. Roebling, of whom the late Charles Hewitt said: "His name is one known wherever a knowledge of science has gone, as perhaps the most successful engineer of the age. He was gifted with the ability to devise and execute with equal success, and hence deserved and received the just praise of the scientific world."

## Motor Control Systems

The evolution of variable speed control systems has been toward simplicity, as in other branches of the electrical field. It is not many years ago since the five-wire system for obtaining variable speed was considered very favorably. For economy of current consumption this method will probably never be surpassed, as the use of different voltages between wires gave almost unlimited opportunity to run without the insertion of resistance. But economy of current consumption was very much offset by high first cost, high maintenance and frequent shut-down for repairs.

This system soon worked down to the later and popular three-wire plan, wherein either two voltages, as 110 and 220, became available, or 65 between two wires, 155 between two others, and 220 between outsides. Either of the two latter is occasionally used now, but mostly the straight two-wire single-voltage system is adopted.

In this system, if first cost is the main consideration, an armature resistance box is used with a maximum of 2:1 speed control. If more variation is required and first cost still governs, then 2:1 by armature control and 50 per cent. more by field control is often used. But when running cost is the chief factor the entire range of speed control is obtained by the insertion of resistance into the field circuit only. By the use of the compensating, or inter-pole motor, a 6:1 change may be had, but it is very rare for this range to be called for now, though common enough in the first enthusiastic days of variable motor speed. It is seldom that over 3:1 is now asked by machinery makers, and this is obtained by simply making the motor with a field of slightly greater capacity than is required for constant speed service.

In the case of alternating-current systems, the speed control is obtained

by inserting resistance into the rotor, or secondary circuit. This is electrically equivalent to the armature resistance method used with direct-current motors. It means, of course, that losses are large and current-carrying parts are big and heavy.

At present there seems no economical method in sight for alternating-current variable speed. The plan of trying to use frequency changers and other such additional machinery has often been suggested, but, as far as we know, never tried.

Where the polyphase motor requires at least a three-conductor wiring plan the single-phase system requires only two. The current consumption is still heavy, however. There is quite a verbal fight on now between central-station managers as to the relative merits of a straight single-phase system for all purposes as against the two or three-phase system.

The single-phase advocates point to the multiplicity of wiring in the polyphase system and to the difficulty of keeping the phases balanced with load. The polyphase enthusiasts, on the other hand, point out the difficulty of building up a power load on a single-phase system, due to the inability of obtaining satisfactory single-phase motors for all operations and the high cost of these motors under the most favorable conditions.

As the alternating-current systems have practically swept the country, there now being only 300 direct-current central stations left out of a total of 4800, it is reasonable to look for many changes and improvements in alternating-current variable speed systems in the near future.

#### **Kokomo, Marion & Western Traction Company**

As an illustration of what may be accomplished in building up an existing electric railway, lighting and power distributing system, and at the same time strengthening the industrial position of an entire community, the management of the Kokomo, Marion & Western Traction Company furnishes one of the most striking and instructive examples to be met with anywhere in the country. At the time ownership of the system was assumed by the interests now in control, less than four years ago, there was a small street railway and electric lighting plant, having no greater output than 500 kw., a few miles of trackage wholly within the city of Kokomo, and circuits containing several hundred arc and incandescent lamps. To-day 22,000 incandescent and 395 arc lamps in

and about Kokomo are supplied with electric current and more than one-half of the Company's customers have various electric household devices; factories in the vicinity take upwards of 1000 h. p. daily in current for operating motors; the street railway system has been extended to a trackage of ten miles, and a finely equipped interurban line of 28 miles in length extends from Kokomo, a city of about 18,000 inhabitants, to Marion, having a population of 26,000, through several large towns situated in a rich, closely tilled agricultural country. Further extensions are projected to Terre Haute and Lafayette on the west, distant respectively 130 and 79 miles from the eastern terminus of the road.

#### **Setting a Market Value on a Water-Power Plant**

"The value of a water-power plant," says Mr. Charles T. Main, of Boston, "varies extremely with different conditions which govern the first cost, and with the character of the work done. The effect of the head, length of dam, length of canal, distance from canal to river, etc., increase or decrease the cost of construction. Very much better work is done in some places than in others, which increases the value and decreases the depreciation, so that no general rule can be given to cover all cases. The plant must be considered not alone, but in connection with the privilege, each being dependent upon the other, and each affecting the value of the other.

"For the water-wheels themselves, the average life of the wheel is probably about twenty-five years, while the casing might be allowed to outlive two wheels. Iron or steel penstocks, if taken care of, should last probably 100 years, but wooden feeders underground will not last fifty years. Wooden flumes, gates and racks which are exposed to the weather will last about twenty years. Some wooden dams have lasted a great many years, but they are apt to get washed away in freshets. Stone dams, if properly designed and well built, will last for hundreds of years.

"The market value of the wheels would depend somewhat upon their efficiency, independent of their physical conditions: for it might pay to replace them, if water is expensive, by wheels of higher efficiency. The vertical wheels with bevel gears will not produce as much net horse power per cubic foot of water as the horizontal wheels: and with the horizontal wheels the extra expense and danger of breakage of gears is avoided."

#### **Power Station Lighting**

Power station lighting is one of the minor details in the design of a station, but it is nevertheless an important one. Max Collbohm, under the title of "Notes on Power Station Lighting," cites some very definite objections to 25-cycle current lighting, but most engineers will not agree with him about the matter. He advocates the use of direct current from the auxiliary storage battery and an automatic switch for use with the lighting circuits. There are not many cases where it would pay to put in the separate battery and motor-generator set for lighting. Where such apparatus has been installed for operating the oil circuit-breakers, or as a reserve source for excitation, it is entirely feasible to do the lighting from this battery. The automatic switch for the lighting circuits is not a new suggestion, as at least one manufacturer has used such a switch with a spring-controlled automatic release attachment.

#### **Southern Water Power**

The water powers of the Southern States are rapidly coming to rival those of New England, and their development is due in no small degree to the work of the United States Geological Survey, which has for a number of years been making systematic studies of the flow of the streams and the conditions which affect that flow.

The work in Georgia has been carried on for more than a decade, during which period all the more important streams and many of the lesser ones have been measured many times, and records have been kept of daily, monthly and seasonal variations in their flow. Most of the data thus collected have been published from time to time, but so many of the reports are out of print or otherwise inaccessible that Messrs. B. M. Hall and M. R. Hall, who have had charge of the work, have assembled all the data relating to the State in a report just issued by the Survey as Water-Supply Paper No. 197. In addition to descriptions of the streams, records of daily gauge heights and estimates of monthly flow, the report includes tabulated elevations of the surfaces of the streams at specified points, by means of which the fall of the streams can be estimated for use as power, and indicates available undeveloped sites. A simple formula for determining the horse-power when fall and flow are known is also presented, and incidental descriptions of the topographic and geologic features of the State are given. The paper is ready for distribution, and copies may be obtained without charge by applying to the Director of the United States Geological Survey, Washington, D. C.

# Protective Devices

H. B. GEAR and P. F. WILLIAMS

Commonwealth Edison Co., Chicago

WITH the introduction of constant potential distribution for incandescent lighting, engineers were confronted with the necessity of providing some form of protection for generators and circuits, which would save them from the effects of an abnormal flow of current when the circuit was accidentally crossed or short-circuited. This problem was fairly well solved for the conditions met in the early stages of the art, but it has reasserted itself with each increase in voltage and with the development of power stations of very large capacity. New and different solutions have been found for each case and the problem is still a live one.

In the direct-current plants which were first installed the circuits were operated at about 110 volts. The most natural means of securing protection to the apparatus was the use of a device to automatically cut off the supply of electricity when more current was drawn from the circuit than it could safely carry. The presence of an overload or short-circuit was thus indicated in a way which required prompt action in the correction of the difficulty. It was found that wires of lead, tin and similar soft metals having a low melting point had a relatively high electrical resistance. This combination of physical properties afforded means by which an automatic cut-out could be provided in the form of a fusible connection inserted at the proper point in the circuit. These 110-volt circuits were therefore protected by the insertion of short pieces of soft wire, known as fuses, which were so arranged that the melted pieces could readily be replaced after conditions on the circuit had been restored to normal.

In another method which was more elaborate a solenoid connected in series with the circuit tripped a spring which opened the switch in case of overload. This was called a circuit breaker.

The use of fuses for protection against overloads and short-circuits in lighting systems became universal because of the simplicity and low cost of fuse renewals.

The blocks used for the support of fuses have been of various types. The earliest forms were of wood, these being followed by slate and other stone and later by porcelain. In its primitive form the fuse consisted of a piece of lead wire secured under binding screws at each end. The uncertainty of this form of contact re-

sulted in fuses blowing when they should not, and tips of copper suitably slotted to fit the binding screws were added. The use of wood was abandoned on account of risk of fire from the arc caused by the melting of the fuse. The use of slate and porcelain, while it eliminated the fire risk incident to the wood block, resulted in the chipping of the surface or the cracking of the block in case of the blowing of the fuse under short-circuit with large amounts of power available. The insurance interests therefore forbade the use of porcelain for fuse blocks except where the fuse was enclosed, and required that where slate or marble was used a suitable barrier be placed between the terminals, the purpose of this barrier being to hold the heat of the arc away from the surface of the block, and to reduce the tendency of the arc to burn the contacts and binding screws. This barrier raises the fuse about an inch from the surface of the block and is quite effective.

The danger of fire from the flash which occurs at the melting of the

it cannot be removed without the use of tools. This was found necessary on account of the likelihood of covers being left off. This form of fuse is one of the best and least expensive methods of protecting low voltage branch circuits carrying loads of 1500 watts and under.

The protection of lines carrying larger loads was not found satisfactory with the plug type of fuse as the explosive force was too great when direct short-circuits occurred. The copper-tipped fuse wire known as the link fuse serves this purpose economically and is quite satisfactory for loads up to 50 kw. or more at low potentials. The link fuse, however, is unsafe unless enclosed in a fire-proof box and mounted on a slate base with a suitable barrier between the terminals.

The danger arising from the use of open link fuses led to the development of a large variety of enclosed cartridge fuses. Most of these consist of a tube of fibrous material in which the fuse is mounted, and a filling around the tube of certain fire

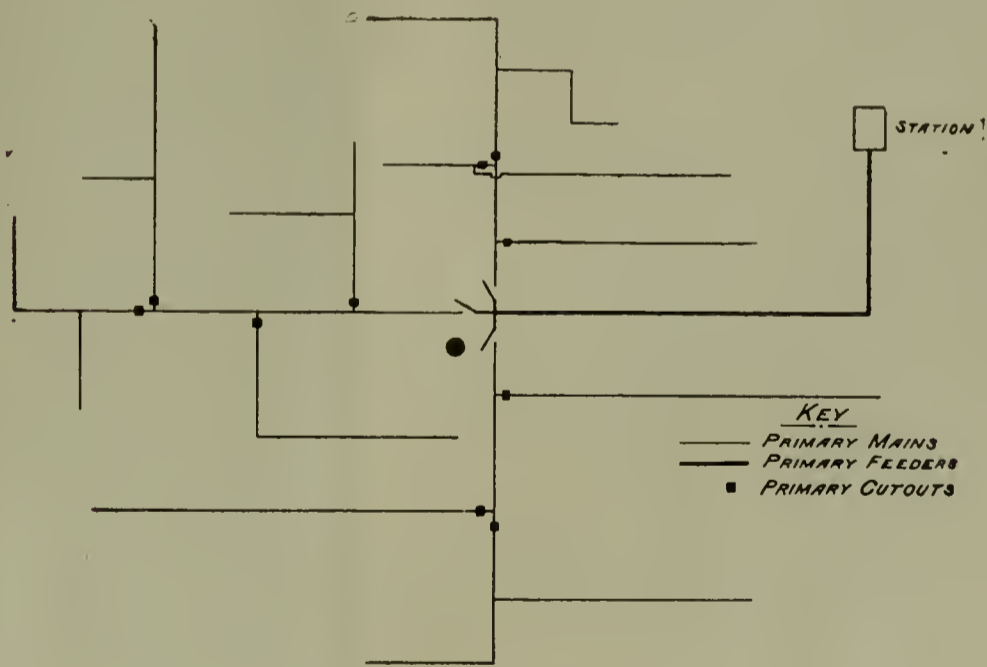

FIG. 1

fuse when mounted on an open block led Edison at an early date to devise a form of enclosed fuse which could be easily replaced without the use of tools and which could be refilled when blown at small expense. This fuse is the now very familiarly known Edison plug fuse. Originally glass was used as the insulating medium and the cover was made removable, but it is now made of porcelain instead of glass and the cover is attached so that

resisting powders which absorb the vaporized metal when the fuse blows and smothers the arc. Connection is made at the ends by means of brass or copper terminals, the copper being used on the fuses designed for currents of 50 amperes and upwards.

The use of glass and other non-porous substances in place of the fibrous tube has not been successful, as the pressure generated by the vaporization of the fuse metal within the

tube must have means of escape and the rigidity of the glass and similar solids is such that the tube is very apt to be exploded when the fuse blows on short-circuit. The concealment of the fuse wire within the tube makes necessary some device for indicating when the fuse has melted. This consists usually of a hole in the tube which permits a small portion of the arc to burn a paper covering, thus indicating at the surface that the fuse has melted.

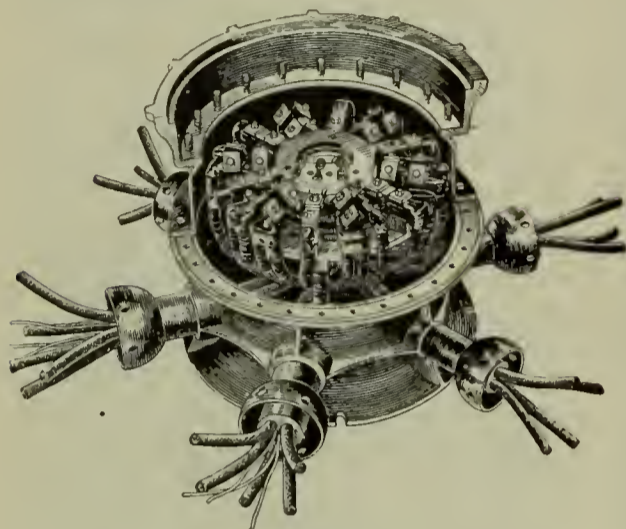

Fig. 2

The cost of installation and maintenance of cartridge fuses is necessarily several times greater than that of the link fuses. This has greatly retarded their adoption for low potential circuits, where the Edison plug and copper-tipped link fuses are most common. On 250 to 600-volt power circuits, the use of cartridge fuses is quite general.

It is an unfortunate condition too frequently found that where the designing engineer has provided a safe and effective equipment of protective apparatus of the cartridge type, the operating engineer or manager, who knows little of the proper care of the apparatus, permits its effectiveness to be destroyed by the use of temporary devices designed to keep the circuit going but to postpone the expense of renewing the fuse. In many such cases the designing engineer might better provide the cheaper installation of link fuses properly enclosed in boxes and have an installation which is not so likely to be abused.

The best design of a method of protection for a distributing system is necessarily a compromise between conflicting conditions. On the one hand the number and location of fuses should be such that the area affected by the occurrence of trouble should be as small as possible, while on the other hand the fuse is a weak point in the circuit, prone to operate when it should not, and therefore should not be multiplied unnecessarily.

In distributing electricity by overhead lines over an area where the load

is scattered so that mains are not interconnected as shown in Fig. 1, experience has demonstrated that the arrangement of fuses indicated presents a reasonably satisfactory compromise between the requirements of minimum area affected and minimum number of fuses.

The less important branches are isolated from the trunk feeds when trouble occurs on them without disturbing the remaining branches. In case of trouble on the trunk feeds the circuit is opened automatically at the station. If it has burned itself clear, as often happens, the circuit is closed and service is resumed very promptly. If it has not cleared itself the trunk feeds must be successively opened at the feeder end by a trouble man, until the one in trouble is located. The remaining portions of the circuit are then put into service and the trouble is located on the affected main as soon as possible. It has been found undesirable to provide fuses at the points where the heavy mains leave the feeder, as they frequently blow when they should not due to temporary overloads, deterioration of contacts or to trouble on some small branch which is severe enough to cause both branch and main fuses to blow simultaneously.

supply so arranged that the occurrence of trouble will cut out reasonably small districts. Fuses at each junction are unnecessary and involve more risk of trouble by blowing when they should not, than value in protecting the line against extended interruption. The work of repair is relatively quick and it is therefore justifiable to risk larger areas than with low-tension underground lines.

In direct-current underground low-tension networks, the work of sectionalizing must be done with the highest degree of refinement, owing to the density of the load, and the corresponding seriousness of an interruption when it occurs.

Trouble on a distributing main or service taken from it must be limited to the block in which it occurs, and if lines are carried on both sides of the street, it must be restricted to one side of the street. Trouble on an underground main is usually of such a nature that considerable time is required to make repairs so that service may be resumed. For these reasons it is usual to place fuses in underground mains at all points where they are connected into the system, so that in case of trouble the section affected will cut itself out and avoid the spread of the trouble further.

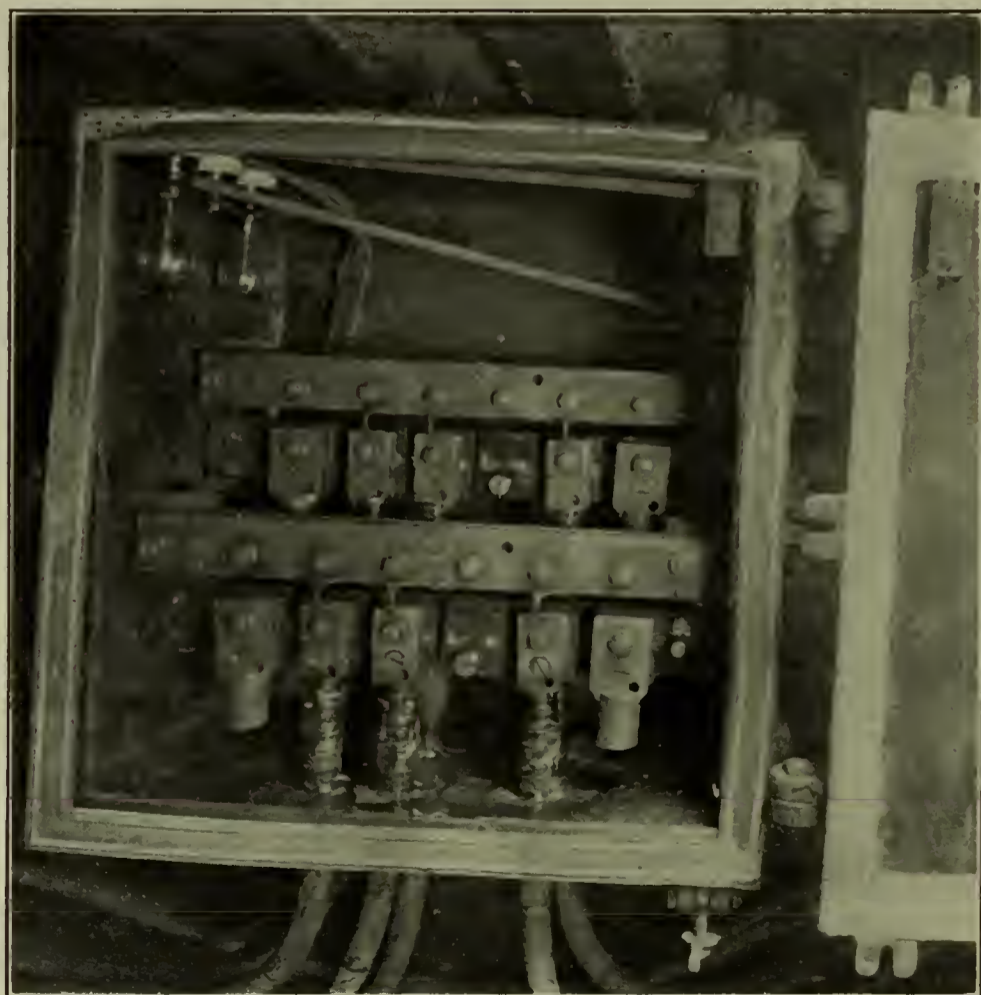

Fig. 3

In overhead low-tension networks, using weatherproof wire, the danger of short-circuit is very slight, if the lines are properly maintained, and it is therefore usual to omit fuses except at a few important points of

In the early Edison systems a junction box was provided for underground work similar to that illustrated in Fig. 2. The fuse clips were equipped with copper-tipped fuses made of sheet fuse metal which pro-

duced a large amount of vapor when it blew under short-circuit and were subject to depreciation which caused them to heat and blow unnecessarily at times. This difficulty was largely obviated later by the introduction of sheet copper fuses such as those shown in Fig. 3, which are now in

It is therefore necessary to provide primary fuses at each transformer and a sufficient number of primary main fuses to properly sectionalize the load and limit the area affected. In general, the likelihood of trouble in transformers and primary mains should not be greater than in the

In alternating-current systems the tendency of the arc to hold when once established by the blowing of the fuse is fortunately less than in direct-current. This is due to the reversal of current twice during each cycle which permits the terminals to partially cool, as the wave of current passes through the zero point. For this reason the use of fuses designed for 250 volts direct-current is permitted by the insurance authorities for alternating-current circuits up to 440 volts.

Transformers should be provided with primary fuses of such size that they will not blow unnecessarily, and it is not advisable to attempt to protect transformers against ordinary overloads on this account. It is therefore usual to provide primary fuses having about twice the normal rated capacity of the transformer. The following table represents common practice on 2200-volt systems:

K. W. CAPACITY	SIZE FUSE
1 K. W.	3 amp.
2 "	3 "
3 "	3 "
4 "	3 "
5 "	5 "
7½ "	10 "
10 "	10 "
15 "	15 "
20 "	15 "
25 "	20 "
30 "	20 "
40 "	30 "
50 "	40 "

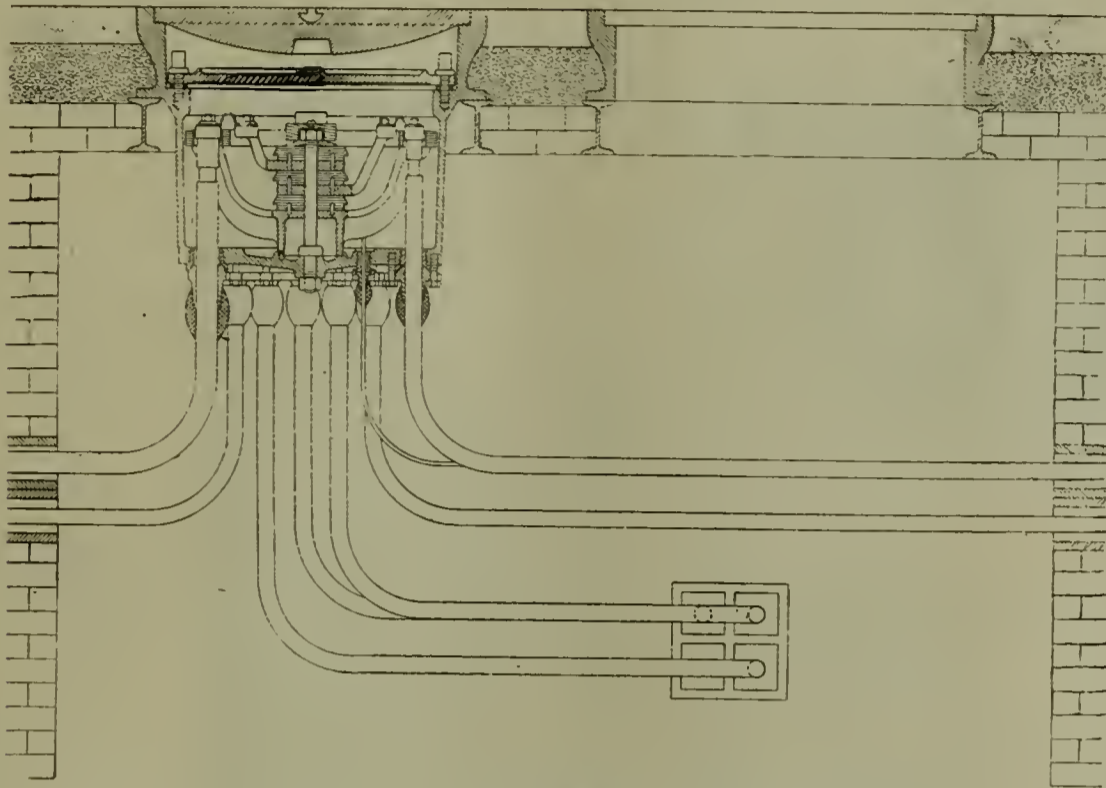

Fig. 4

general use. This greatly reduced the weight of metal required and therefore the severity of the arc at the time of the blowing of a fuse. The section of the copper fuse at the point where fusion takes place is designed to carry its normal rated load without undue temperature rise and to fuse at about twice its normal rating. The types of junction box used in connection with modern cable systems are shown in Figs. 3 and 4.

The feeders are fused at the point where they feed the network to protect the network against trouble on the feeder. It is not usual in large systems to provide fuses on the feeder at the station bus, as the operator on duty can open the switch and disconnect the feeder in case it is necessary. The likelihood of feeder fuses going out under emergency conditions when they should not makes it safer to depend upon the operator for protection against feeder trouble, which in any case is rare.

In alternating-current underground low-tension networks supplied by low-tension feeders, the same general principles apply as in the case of direct-current systems.

With networks supplied by primary mains and transformers, as in Fig. 5, the situation is more complicated. The system must be protected against failure of transformers and primary mains, as well as of low-tension mains.

secondary mains, if the subway type of transformer is used in drained manholes.

The severity of the arc on circuits

The type of fuse which has proved most satisfactory for transformers up to 30 kw. is illustrated in Fig. 6. The removable porcelain plug carries con-

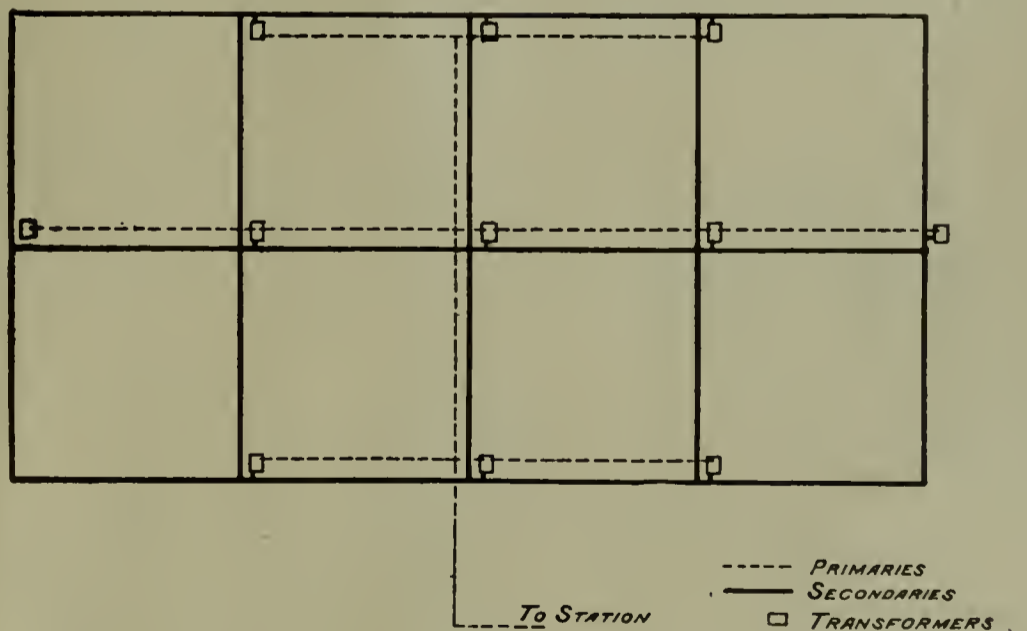

Fig. 5

operating at potentials of 500 volts and more necessitates the use of some form of enclosed fuse on such circuits. The blowing of a 50-ampere link fuse in a slate-lined iron box on a 500-volt direct-current circuit has been known to totally wreck the box and in some cases to hold on long enough to partially melt the iron case.

tacts on which the fuse is mounted and the heat formed by the melting of the arc produces an expulsive action which blows out the arc. This form of fuse is very satisfactory with aluminum as the fuse metal up to 15 amperes at 2200 volts. Above 15 amperes the enclosed fuse in some form is preferable. The common cartridge

type is satisfactory in capacities up to 50 amperes at 2200 volts, except where it is subject to moisture. In such circumstances the arc-smothering filler absorbs moisture, and fails to perform its work properly when the fuse blows. It is not practicable to fully shield the cartridge fuse from moisture when it is installed out of doors or underground and the use of this type of fuse on general distribut-

ing systems is not wholly satisfactory. Various other types of fuses have been devised from time to time, many of which have never been generally used. Of those which have come into a limited use, there is one which consists of two lignum vitæ blocks between which the fuse is mounted. A hole is provided in one of the blocks to permit the ejection of the vaporized fuse. The use of lignum vitæ prevents shattering and yet it is fireproof to a momentary flash. This fuse is serviceable up to 50 amperes at 2200 volts.

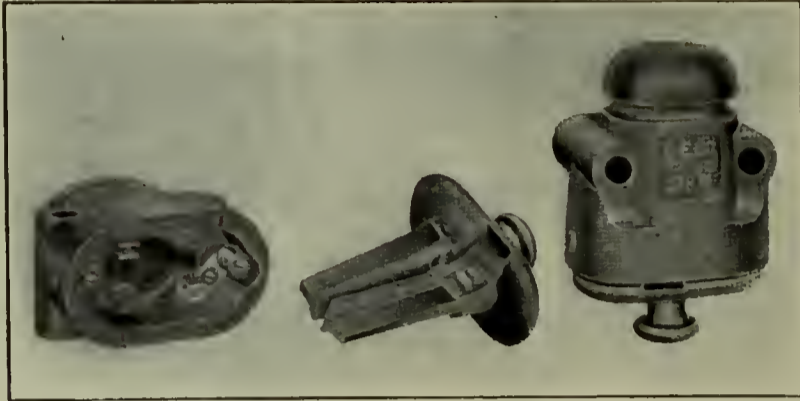

Fig. 6

count of gradual deterioration which causes fusing when no emergency exists.

At voltages higher than 4000, the use of fuses is limited to the sizes below 30 amperes, and above 10,000 volts they are used only for transformers of small capacity such as pressure transformers.

Size Wire B. & S. . . . .	8	10	12	14	16	18	20	22	24	25
$\sqrt{(d)^3}$ . . . . .	.046	.0325	.229	.0162	.0114	.0081	.0057	.004	.0028	.002
Fusing Current Copper	472	334	235	166	117	83	58	41	29	20
Fusing Current Aluminum . . . . .	349	246	174	123	86	61	43	30	21	15

At pressures up to 600 volts, cartridge fuses are made for currents up to 600 amperes. The cost of renewals in the larger sizes is such, however, that it is usually preferable to employ circuit breakers rather than fuses.

The operation of the fuse being dependent on the elevation of its temperature, it is apparent that the reliability of its performance on overloads depends upon the ease with which heat may be radiated. This is not a factor in case of short circuit, as the temperature rise is so rapid that radiation has no appreciable effect.

Under normal load conditions the fuse may fail to carry its rated load because of insufficient opportunity for radiation or because of insufficient contact at its terminals, which adds to the heat instead of assisting in carrying it away. A fuse with a long length of wire between terminal clips will generally act at a lower current than one made of a short length, and a fuse mounted on lugs of liberal area will carry more than the same fuse connected to small lugs.

The action of enclosed fuses is in general somewhat more sensitive than open link fuses on account of the more restricted radiation of the enclosed fuse.

The time required to cause a 5-ampere fuse to operate at different loads is illustrated in the curve of Fig. 7. This curve is typical of the action of fuses of all sizes, the absolute values varying with different types and capacities.

The law governing the operation of fuses was worked out by Preece in 1888. It may be stated thus:

$$\text{Current} = a\sqrt{(d)^3}$$

$d$  being the diameter of the wire expressed in inches. The value of the constant  $a$  is different for each metal. For copper it is 10,244, for aluminum 7585, for lead 1379, for tin 1842, and for iron 3148.

For instance, with a No. 10 B. & S. copper wire having a diameter of 0.102 inch, the fusing current is

$$c = 10,244 \times \sqrt{(0.102)^3} = 334 \text{ amperes}$$

The fusing current for some of the smaller sizes of wire are as follows for copper and aluminum:

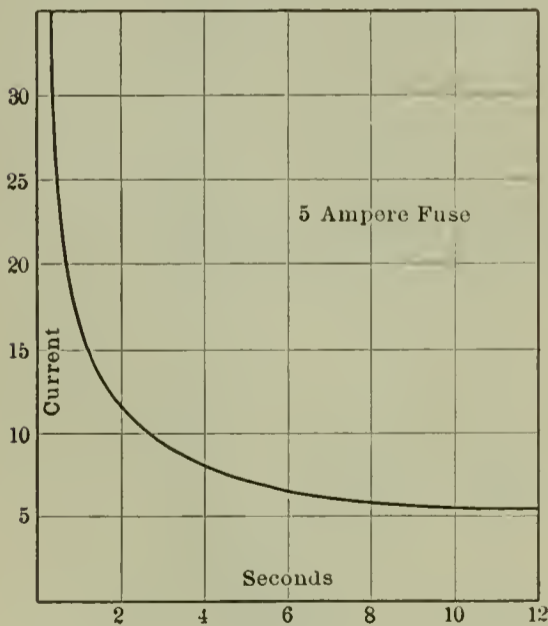

Fig. 7

Another form consists of a tube through which the fuse runs, which is open at one end so as to expel the gases violently when the fuse blows. The tube is of fibrous material and is not well adapted for out-of-door service. Various other forms of expulsion-type fuses have been used, but not very generally.

Under circumstances where automatic cut-outs operate at frequent intervals and on circuits operating at high voltages or controlling loads of 100 kw. and upward, the circuit-breaker possesses certain advantages over the fuse as a means of protection.

In general the use of circuit-breakers is expensive in first cost but inexpensive in operation, while the use of fuses requires a minimum first cost with a maintenance charge.

In central station distributing systems the load is usually not widely variable and protective devices are not called upon to act except in case of line trouble. The use of fuses is therefore generally preferable in a distributing system except on those feeder and transmission lines which carry large loads at high voltages where the use of fuses is not feasible.

On low potential circuits the circuit-breaker consists of a switch of a design suitable to control the maximum load of the circuit, with which is combined a coil connected in series with the circuit and so arranged that it will lift a movable core and release a spring-actuated mechanism which opens the switch. This plunger is designed to operate whenever the current exceeds a predetermined value.

Circuit-breakers are commonly de-

Aluminum has been employed as a



signed so that they may be adjusted to operate at any point between 80 and 150 per cent. of their normal rated capacity. It has been found in practice that a magnetizing force of about 1000 ampere turns is ample for the operation of the tripping device.

In alternating-current systems the design of the circuit-breaker is modified somewhat, because of the fact that on such circuit-breakers a series trans-

verse-current trip releases the spring mechanism which in turn opens the breaker.

In electrical operation the power for both closing and opening the circuit is supplied through solenoids or motors. The larger sizes and higher voltage breakers, such as those shown in Fig. 8, are usually controlled electrically, on account of the power required and because of the greater facility of oper-

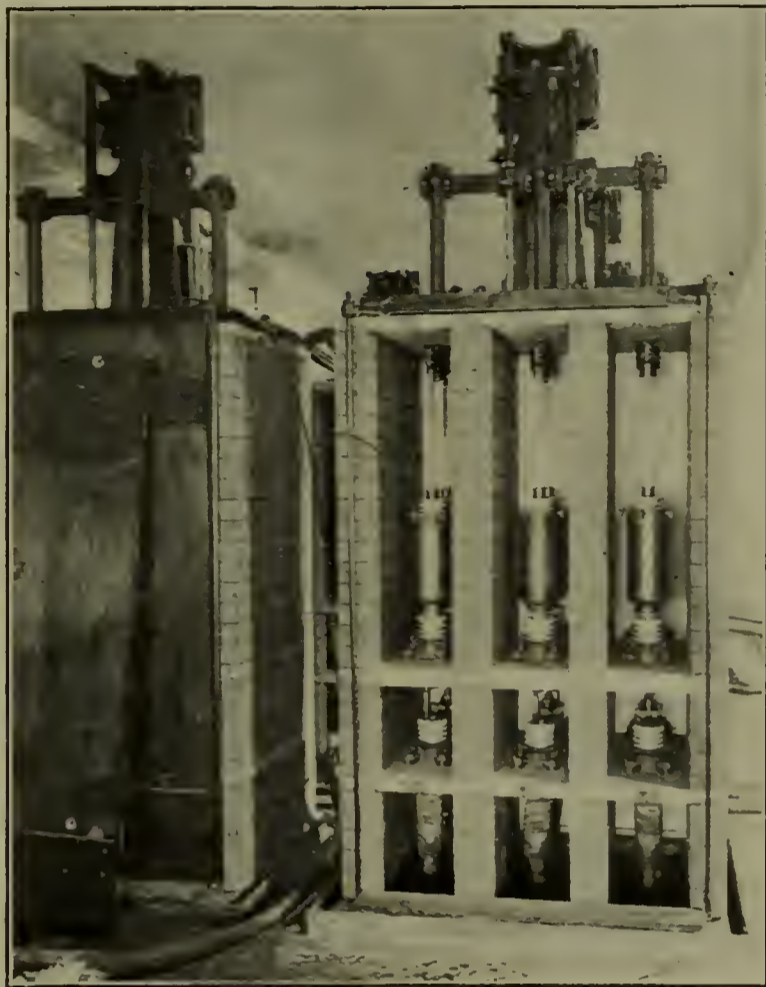

Fig. 8

former may be installed at a convenient point in the main circuit and small wires carrying a few amperes may be led from the series transformer to the tripping coil of the circuit-breaker. On circuits operating at 2200 volts and over, the switch is commonly of a design which breaks in oil. The use of the series transformer on such circuit serves the double purpose of providing a small current for operating the tripping device and of insulating the mechanism from the high potential circuits.

Circuit-breakers are designed for two general classes of service in distribution systems, protection against overload or short circuit, and protection from the reversal of the flow of energy. The first class is known as overload circuit-breakers, while the second is called reverse-current apparatus.

The operating mechanism of the circuit-breaker is controlled by hand or electrically by solenoids.

In hand-operated breakers, the power required to open the circuit is usually stored in springs during the act of closing. The overload or re-

verse-current trip releases the spring mechanism which in turn opens the breaker. The latter feature is quite essential in large systems where the number of switches to be handled during an emergency demands a system of control by which an operator may work rapidly and without great effort.

Direct current is usually available in stations and substations from the exciter system, and is often safeguarded by a battery, which assures control at all times. It is therefore quite universal to use direct current for the operation of electrically actuated breakers. With the exception of the three-phase four-wire system it is not usual to employ single-pole circuit breakers in alternating-current systems, as all the poles must be opened in order to avoid electrostatic disturbances. In the four-wire system the use of the neutral wire prevents distortion of the phases when one pole is opened, and single-pole breakers are therefore used in such systems.

With electrically controlled apparatus the protective device is really the relay which energizes the control circuit. This consists in general of an

alternating-current solenoid energized by the main current transformer of the circuit, the plunger of which closes the direct-current circuit and energizes the mechanism of the circuit-breaker as shown in Fig. 9.

Other direct-current control circuits are provided for the use of the operator in opening and closing the breaker under normal conditions.

In order to prevent the operation of the circuit-breaker under momentary rushes of current, it is usual to design the relay for operation with an inverse time element. That is with the relay set to operate at 100 amperes after 10 seconds, it will operate at about 300 amperes in five seconds and almost instantaneously at 1000 amperes. This characteristic results in prompt action in opening the circuit under short-circuit, while reducing the liability of unnecessary interruption under minor disturbances.

This result is accomplished by damping devices of various kinds, such as dashpots and air bellows. The air bellows has proved the most satisfactory in view of its simplicity and reliability. Recent improvements made in the air-release valves have improved the action of the bellows type of relay on heavy overloads, so that their operation on short circuits is more prompt and the damage reduced accordingly.

The arrangements of relays on a feeder or transmission line must be such that the occurrence of a short-circuit between any two wires will open the breaker. On single-phase circuits one relay is sufficient to accomplish this. On two-phase three-wire systems used for power only

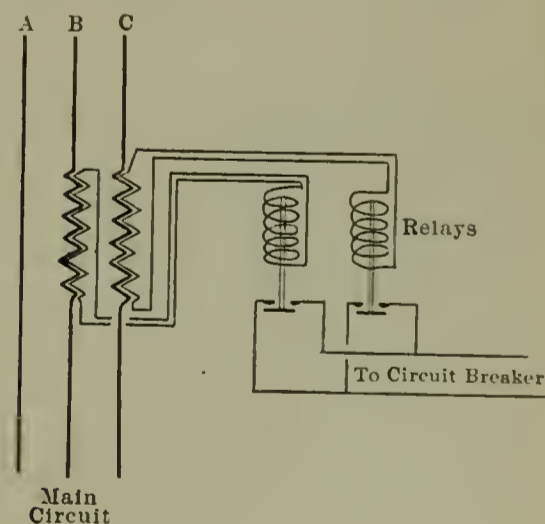

Fig. 9

which are not grounded normally one relay in the middle wire may be made to protect all three. In distribution circuits carrying lighting and power it is preferable, however, to provide separate relays and circuit-breakers for the two outer wires so that only one phase is interrupted in case of trouble which does not short-circuit both phases. This is also true of the four-wire two-phase system. In the

three-wire three-phase system without grounded neutral the occurrence of a short-circuit between any two wires interrupts service on all phases and relays are required in two wires so that at least one will open the circuit in case of trouble on either phase. The circuit-breaker is therefore a three-pole breaker.

In the four-wire three-phase system, or in a three-wire three-phase system, having the neutral point of the gener-

substations with duplicate transmission lines, it is usual to have conditions similar to those shown in Fig. 10. It will be noted that each transmission line is protected at the main bus by overload relays, while each converter is protected by reverse current relays on the direct-current side and by overload relays on the alternating-current side. The latter will, however, operate on overload without regard to the direction of flow of energy.

load relays on alternating-current side.

If the trouble is severe and the lines 2 and 3 are comparatively short, it may also happen that the current drawn from the direct-current bus may have operated the overload relays on the lines 2 and 3 at the main bus or on the converters operating from them at the time of the accident. If so the entire equipment which was operating on the three lines is shut down until it can be determined by test which of the three cables is faulty. This requires some time and the resumption of service is usually not possible in less than 10 to 15 minutes, and if convenient testing facilities are not provided much longer. The time limit of the various relays should be so adjusted that the number of relays operated in an emergency will be a minimum.

In case the overload relay at the main bus on line 2 and but one reverse current relay on the converters carried by this line had opened, the remaining converter connected to line 2 would continue to operate as an inverted converter. This might cause it to race and go to pieces, causing great damage to machine and substation. It is therefore important that converters be further protected by speed limit devices which will operate the direct-current circuit-breaker whenever the speed exceeds a safe maximum value. Such devices usually operate on the principle of centrifugal force, and being called upon to act rarely should be tested out at regular intervals.

The protection of distributing systems from the effects of lightning might properly be classed with other protective measures, but the discussion of the subject involves so many considerations that it is regarded as preferable to treat it separately.

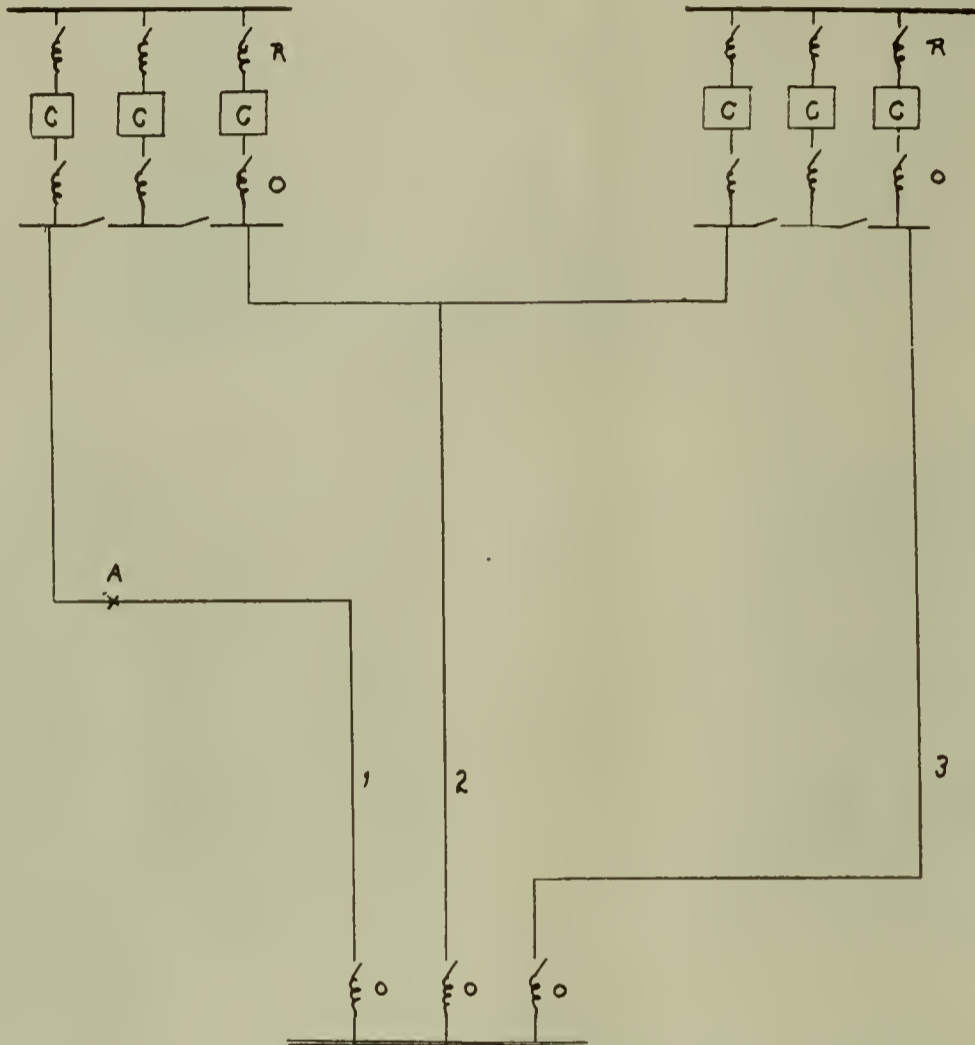

Fig. 10

ator winding grounded, it is essential that relays be installed in each phase wire, since the occurrence of a ground on either phase conductor results in a short circuit. In the four-wire system only the relays on the phases affected come into action. In case of a ground on one phase the circuit-breaker on that phase opens without interrupting service on the other two phases.

Where several lines or banks of transformers are operated in parallel or where rotary converters supply a network, it is necessary that the apparatus be protected against a reversal of the flow of energy in case of emergency.

Various methods have been employed to accomplish this result, most of which employ a pivoted arm actuated by windings so arranged that when the direction of the flow of energy is reversed, the arm closes the operating circuit and opens the circuit-breaker.

In a large system embodying several

In case a fault develops at the point A on line 1, current will be drawn from the main bus and from the direct-current network through the converters which are operating from line 2 at the time the fault develops. The overload relay on line 1 at the bus should at once cut off the supply from this source. The supply through the converters should also be cut off by the action of the reverse current relays on the direct-current side of the converters, and perhaps by the over-

Printing Press Data.

The Whitlock Company, manufacturers of a well-known line of large printing presses, has recently added two new sizes to its list of machines. In this connection they have taken the opportunity of revising the data relating to their whole line. The accompanying table gives all the data up to and including the new presses.

Press No.	Size Bed	Impressions per Revolution	R. P. M. of Driving Wheel			Size, Press Pulley	Impressions per Hour			HP of Motor
			Min.	Nor.	Max.		Min.	Nor.	Max.	
0 0 0 E	46x62	5	58	96	125	26x6	700	1150	1500	5
0 0 E	43x56	5	67	104	135	26x6	800	1250	1625	4
0 E	39x52	5	83	120	150	26x6	1000	1440	1860	3½
0 - 1 E	39x52	5	83	120	155	26x6	1000	1440	1860	3½
1 E	35x47	5	83	121	158	26x6	1000	1450	1900	3
2 E	29x42	5	92	139	180	26x6	1100	1660	2160	3
3 E	27x40	5	108	154	200	26x6	1300	1850	2400	2½
5 E	27x31	5	125	167	220	26x6	1500	2000	2700	2
G Y	46x65	13.36	201	294	361	26x6	900	1320	1620	5
G U	41x52	12.27	209	295	368	26x6	1020	1440	1800	4
G O	36x48	12.27	245	335	425	26x6	1200	1620	2040	3½

# Ground Detectors

By M. G. BUCKLEY

FOR 110-volt 2-wire direct or alternating-current systems the long-used method of two lamps is still in vogue on account of its cheapness and simplicity. As shown in Fig. 1 it consists of two 110-volt lamps in series. Each lamp gets half voltage normally. But a ground on one leg gives an additional path back to the other side, causing the lamp on that

As stated above, the voltmeter dial is the one which usually contains the connections for giving the above, in addition to the other points which allow voltage readings between legs to be read.

Above 750 volts direct-current there has been no call for a direct-current ground detector. The 1200-volt trolley roads now building will have spe-

cially over this 100 volts and 5 amperes, but its scale is marked to read 110 volts, 1100 volts or 2200 volts, as the case may be, giving the attendant a direct reading.

On account of the difficulty of building and insulating high potential instruments for switchboard work a change in the type of apparatus employed occurs at about 2200 volts, at

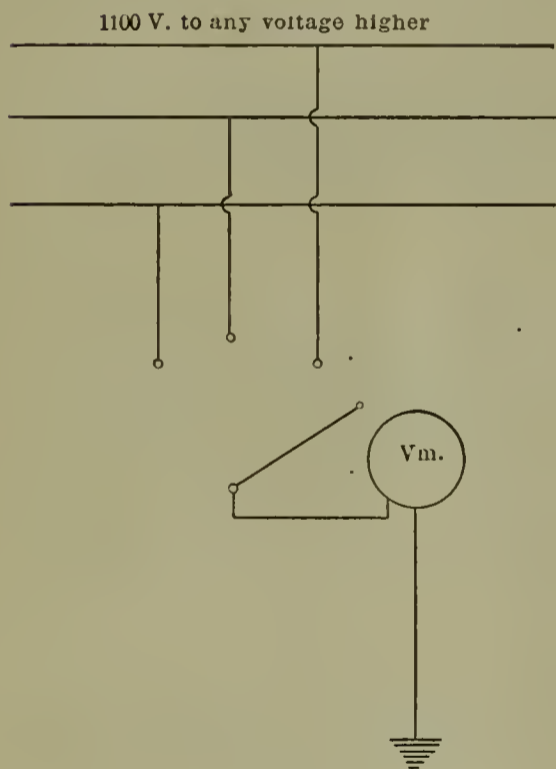
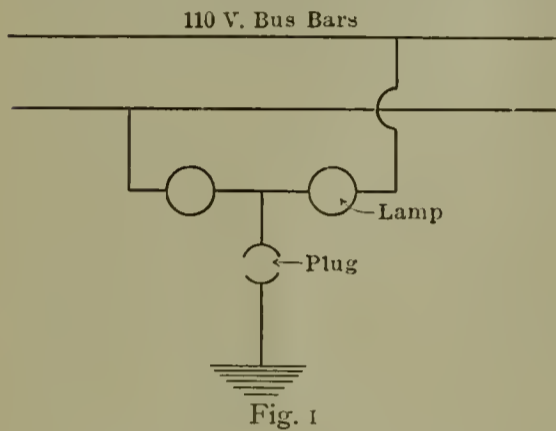

side to brighten up. The filament which had been burning a dull red will now approach full candle-power in proportion to the severity of the ground.

On systems of three or more wires and on voltages not exceeding 750 volts it is customary to substitute a voltmeter for the lamps shown above. This voltmeter is easily arranged to read the potential between any wire and ground. The regular switchboard voltmeter is the one most often used for this purpose. Fig. 2 shows a simple arrangement for reading grounds by instrument.

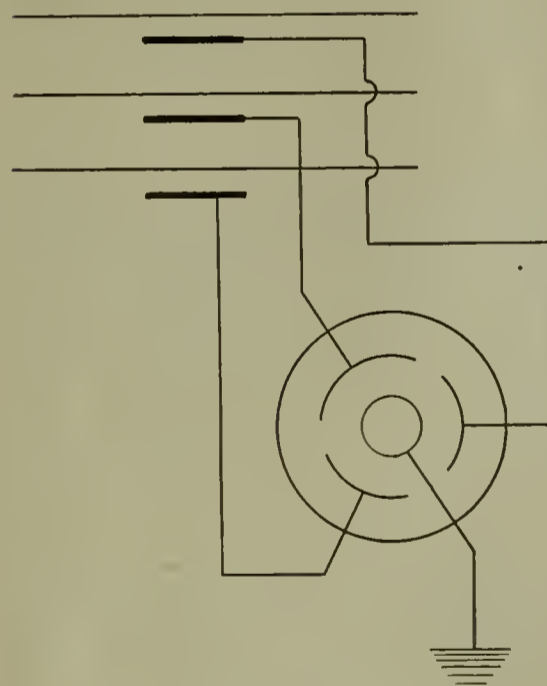
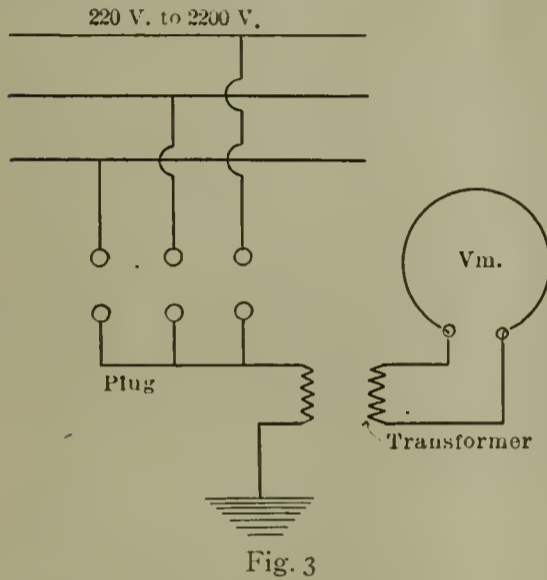

cial high-reading instruments built for them.

On alternating-current systems the method now changes to the use of a transformer. In fact from 220 volts to 2200 volts it is quite common to use the transformer. Fig. 3 shows this method.

The transformer in this case is of the right ratio to give 100 volts and five amperes on the low potential side when full bus-bar voltage is being impressed on the high-tension side. The voltmeter will, therefore, never get ac-

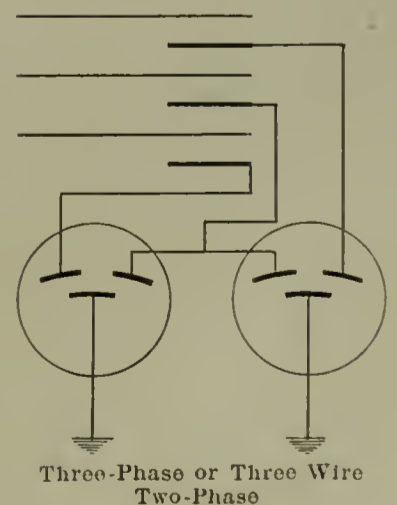
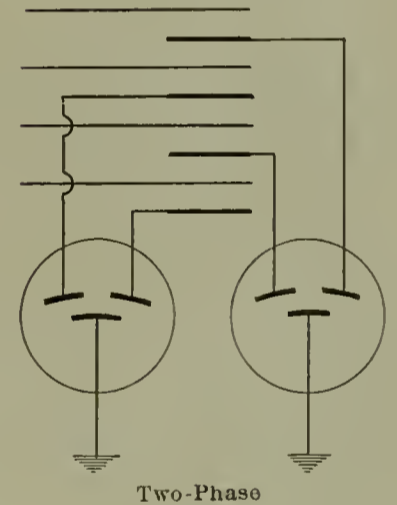
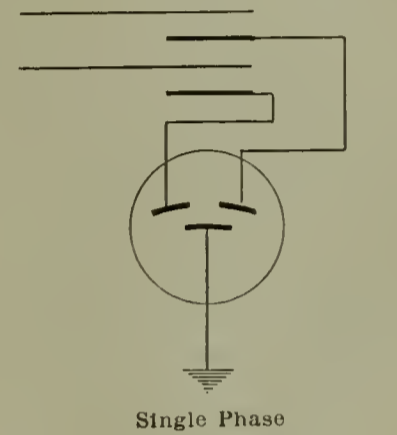

Fig. 5

which voltage the static voltmeter is usually introduced.

In this type advantage is taken of the well-known fact that in a condenser a charge on one surface induces an opposite charge on the other.

The static voltmeter and condensers give the effect of two condenser surfaces in series. In any instrument the surfaces would necessarily have to be quite close together. Yet the voltage might have a jump spark distance of several inches. The line condenser is, therefore, made in the form of a tube to slip onto the wire. The wire itself forms one side and a sheet or tube of copper the other. The insulation between the two is built strong enough to withstand several hundred thousand volts. As a result of this the voltmeter can be freely handled. The working vanes are brought to within a quarter of an inch of each other, and a ground will disturb the balance of the charges, causing the lower vane, which is free to move, to swing towards or from the side in trouble.

Three-phase meters have been made and used as shown in Fig. 4.

Here the center vane is free to move and moves away from the grounded side.

On account of the cheapness of this apparatus it is becoming more and more common to use this static type on systems even as low as 1100 volts.

Of course, there are many variations of the methods shown here, but these form the basis of all systems.

#### Notes on Power Station Lighting

BY MAX H. COLBOHM.

WHEN working out a lighting system, the following principles must be embodied:

1. The system must be thoroughly reliable.

2. It must be simple in installation and especially so in operation.

3. Enough generating capacity must be obtainable to act as a reserve for the total amount of lighting, without necessarily duplicating the original source for lighting.

4. A certain number of lights at prominent places all over the station must be provided as emergency lights so that in case of a break-down of the main source of supply they automatically connect to an independent emergency circuit.

5. The system must be economical in installation and operation.

These principles are enunciated at first in order that they may be in mind during the reading of these notes.

Large power stations, and especially hydroelectric plants, are built exclusively in this country for alternating-current generation, and as the bulk of their load is sold for power work the frequency of the system is generally 25 cycles. This alternation is unfortunately somewhat low for lighting purposes. At such a low frequency arc lamps cannot be used on account of

their flickering, and the same holds true, though not to the same degree, for ordinary incandescent lamps. Only heavy filament lamps like the Nernst operate at this frequency without flickering.

The disadvantages of 25-cycle alternating-current for power station lighting are:

1. In the absence of arc lamps, a large number of incandescent lamps have to be used, which, on account of their lower efficiency, require an increased amount of energy, thereby increasing the size of cables, wires and conduits. Furthermore, as the allowable drop for incandescents is very much less than for arcs, more feeders, wires, conduits and panel boxes are required in order to avoid too long runs from the panel boxes and also to bring the installation up to the Underwriters' ruling in regard to the maximum number of lights per circuit.

tinuously at a low and undesirable efficiency. The voltage of the power system must for the reason given before, be comparatively low, not above 250 volts, and the power wiring therefore becomes heavy and rather expensive.

3. The station light-and-power transformers get their supply either from the main low tension bus bar (generator voltage) or from one of the large generating units running separately and supplying generally a local power market near by with in-ergy, at the same time feeding the station itself. In each case the light transformer will undergo the same voltage variation as the main line or the local power system. This may be quite considerable and cause bad and annoying illumination in the power house.

In view of these numerous and strong disadvantages, the writer be-

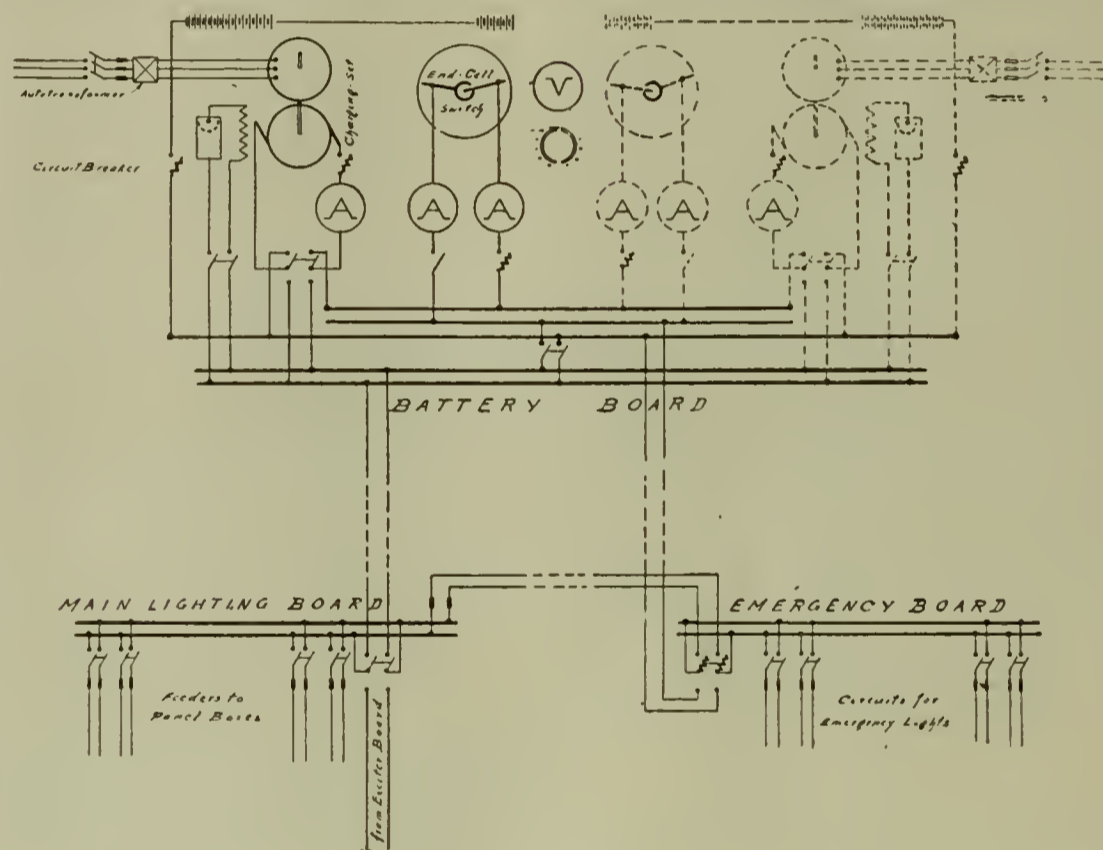

Fig. 1

This again enlarges the main station supply board on account of the increased number of feeder switches. The light fixtures themselves are considerably more expensive than arc lamps would be for the same amount of light. Altogether it makes comparatively quite an expensive installation.

2. Twenty-five cycle lighting is used in order that the transformer supplying the lighting system shall act as a reserve for the station power transformers; but this means that it must be of the same size and voltage as the power transformer, whereas, the latter is generally more than twice as large as the lighting load requires. Considering especially the very light day-load the transformer will run con-

tinues that in power stations, especially hydroelectric plants, operating at 25 cycles, the direct-current system is more favorable for lighting the station.

In a hydroelectric plant generally no emergency connection can be made to an outside source of supply. An instantaneous reserve must, therefore, be provided by a storage battery large enough to carry the total emergency lighting for about eight or ten hours; also a direct-current generator driven by an induction motor must be installed for charging the battery.

The writer proposes to use this charging set in connection with the exciters and storage battery to make up a simple, reliable and efficient lighting system.

Two things require to be observed:

1. The charging set must be large enough to carry the total lighting load.
2. The storage battery and charging generator must correspond to the exciter voltage, either 120 volts or 240 volts for larger units.

The arrangement is as follows: As seen in Fig. 1, the charging generator is connected through a switch with the main generator bus bars and with the battery charging bus bars respectively. From the generator bus bars a feeder runs to the upper contacts of a double throw switch on the main lighting board; the lower contacts of this switch are connected with the exciter bus bars. By this arrangement the whole station lighting can by a single operation be thrown either on the charging set or on the exciter. As a rule the charging set supplies the system and the exciters are used only in emergency cases. There is generally enough exciter capacity in the station in the form of a reserve unit which may be used in such cases for a short period without interfering with the other exciters.

From the main lighting board a feeder runs to the emergency board

and connects to the upper contacts of a circuit-breaker which is provided with a no-voltage release. A separate set of contacts is so arranged that when the circuit-breaker opens, it connects automatically through these other contacts with the storage battery, as shown in the diagram. The emergency lights, as a rule, therefore, are supplied from the main lighting board and only in case of a break-down are automatically thrown on the battery. This is rather an important point, because in case of an accident when the lights go out there is likely to be quite some confusion and excitement and the operator may not be able to throw all the emergency lights over on the battery before some time, which may be long enough to bring the attendants on the main benchboard and elsewhere into trouble.

The plan as described above is thoroughly reliable, as it provides three independent sources of supply, two of which are each sufficient for the total demand. It is very simple in installation and operation, requiring no additional units. The switches on the main lighting board and emergency board are single throw throughout

except for the one main switch; the size of the switchboards is therefore rather small. In operation only one switch need be attended to on the main lighting board, and attention to the emergency board is entirely automatic. The diagram shows in dotted lines a duplicate outfit of the battery and charging set which may be desired for greater safety in case of a break-down of the first outfit, although a second battery alone without another charging set would be sufficient.

The wiring itself will best be done on the two-wire system and according to the exciter voltage either for 120 volt or 240 volt, preferably the latter, as the bulk of the lighting may very nicely be carried out by pairs of enclosed arcs in series, with only a minor part by incandescents. Although the latter have a lower efficiency on 240 volts their number is not great, and in a generating station itself the increased load is entirely negligible.

The system as outlined above will result in a comparatively inexpensive installation on account of small switchboards, few feeders and panel boxes and the light wiring for arcs.

## The Synchronous Regulating Rotary Converter

J. H. SMITH

The synchronous regulating rotary converter is so simple, both in construction and in the theory of its principle, that the wonder is that it has not been brought into use long ago.

In brief, the theory upon which this rotary converter regulates its voltage

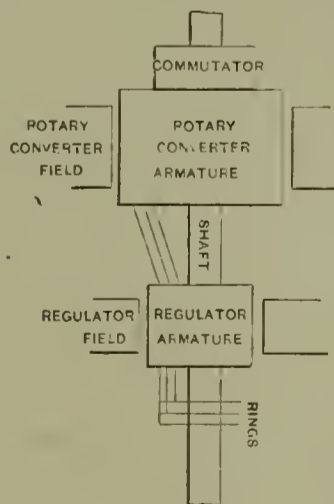

Fig. 1

is as follows: If two direct-current generators are connected in series their voltages are added and the terminal voltage of the set is the arithmetic sum of the two. If now two single-phase alternating-current generators are connected in series their voltages

would be added arithmetically, provided the two machines were mechanically held exactly in phase. Consider two single-phase generators having the same number of poles. Their speeds will be the same and if their shafts were coupled together rigidly at the proper electrical angle the resultant voltage would obviously be the arithmetic sum of the two respective voltages. Now, assume the excitation of one of the machines is constant, and if the other is under the control of the operator, obviously the voltage of the set will be controlled by the field rheostat in the one machine having the variable field. A little further consideration will show that the same principle applies to poly-phase machines, as well as to single-phase machines.

Take, for example, an eight-pole rotary converter and upon its lengthened shaft construct an eight-pole rotating-armature alternator of the common form (see Fig. 1). The generator should, of course, be of the same phase as the rotary converter armature, and it will have to be open-circuit wound for a two-phase machine, and star wound for a three-phase machine. Reference to Figs. 2 and 3 will

show these types of windings as found on the ordinary generators. For further study, consider the case of the three-phase machine; take the alternating-current generator winding shown in Fig. 3, open it at its star point, move the three legs outward from the center in directions parallel with their respective directions, and connect to the corners of the delta of the winding on the rotary converter armature and the result diagram-

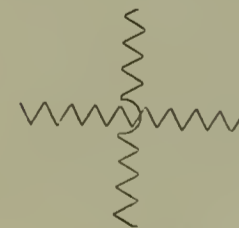

Fig. 2



Fig. 3

matically is shown in Fig. 4. Physically, the relation of parts is shown in Fig. 1. In keying the two armatures on the same shaft, care must be taken that the right electrical relation is secured, that is, the legs of the regulator winding must bisect the angles of the delta.

The ratio of the direct-current voltage to the alternating-current voltage generated in the rotary converter

armatures is a fixed quantity for any given machine, therefore, the only way to raise the direct-current voltage is

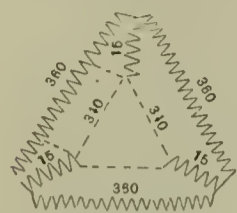

Fig. 4

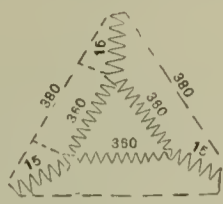

Fig. 5

to raise the alternating-current voltage. There are several ways to do this: By the induction regulator, taps from transformer with Stillwell regulator, compound wound rotary converter having inductance in each of the alternating-current circuits, and the synchronous regulator which we are describing.

*Operation.*—The synchronous regulator acting as an ordinary booster will boost just in proportion to excitation in its fields. The extent of the boosting or the per cent. of regulation obtained is far less limited than in the case of the other types of rotary regulation. Within reasonable limits the generator may be designed to regulate over any desired range.

The regulation may be either up or down and is reversed by simply reversing the field of the regulator.

*Excitation.*—The fields of the regulator are usually separately excited, and therefore completely under the operator's control. Control may also be

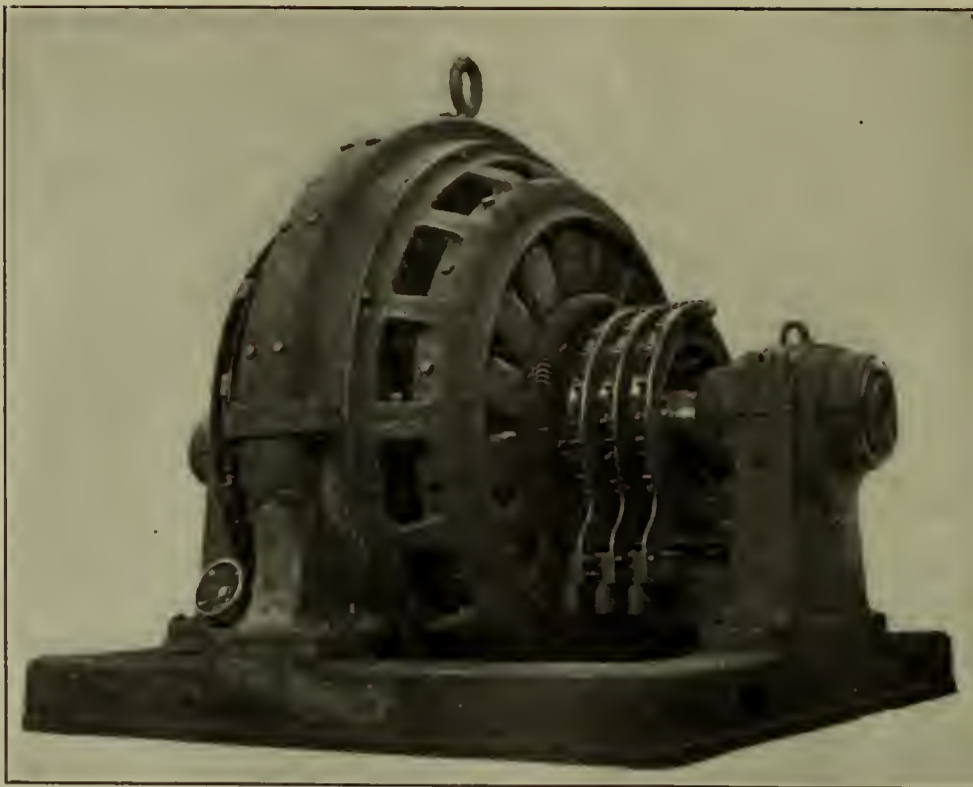

Fig. 6

1000-KW. SYNCHRONOUS REGULATING CONVERTER SHOWING AUXILIARY ALTERNATOR

effected automatically by a volt-meter controller or a Tirrill regulator. The excitation of the regulator may be entirely by the main current from the direct-current side of the rotary converter through the series windings on the regulating machine.

*Advantages.*—The advantages presented by the synchronous rotary converter are (1) greater range of control; (2) more rapid response; (3)

simplified construction; (4) self-contained unit; (5) smaller floor space than that occupied by the converter and the inductive regulator; (6) smaller cost for the outfit.

Ten 1000-kw. machines of this type have been built by the Westinghouse Electric & Mfg. Co. for the New York Edison Co., and have been in operation for nearly a year.

**How to Clean Switchboards**

M. G. BUCKLEY

*Marble Boards.*—Smooth down with a block of pumice stone until scratches are rubbed out. Polish with oxalic acid or "polishing powder."

If acid stains are to be removed, apply an ordinary blotter soaked in chloroform.

Oil stains can be taken out by applying a layer of plaster of Paris mixed with benzoin against the spots.

*Slate Boards.*—Smooth down with pumice and rotten stones. Final polish should be put on with dry hand.

Dirty boards should be cleaned with soap and water only. Never use oil on the enameled surface.

**Power Required in Binderies**

M. G. BUCKLEY

The following is a partial list of machines used in book binderies. Direct-current or alternating-current motors are now used in this field. As most of the machines have heavy flywheels, compound motors are used for direct-current driving and high-resistance rotors (usually squirrel cage) for alternating-current motors.

	R. P. M.	Largest Pulley	H. P.
12x15 Embosser, Sanborn.....	130	36x4	2
17x20 Embosser, Sanborn.....	130	42x5	3
Gluing machine.....	165	24x4	1
No. 1 Smythe case maker.....	160	10x1½	½
No. 2 Smythe case maker.....	260	10x1½	1
Smythe cloth cutter...	320	12x1½	½
Sanborn slitter.....	108	24x3	½
Fortuna paring machine.....	2200	.....	¾
Crawley rounder and backer.....	80	18x3½	1½
Sheridan book trimmer	220	24x3	1½
Lovell covering machine.....	140	16x2½	2
Seybold duplex trimmer.....	200	26x4	3
Thompson stitcher...	125	9x2½	½
Sanborn smasher.....	125	40x5	3
Sheridan signature press.....	345	18x4	3
Sanborn book saw.....	2000	.....	2
Fuller case binder....	200	18x2½	½
Goat & Hibbs backer..	80	18x3½	1½
Smythe casing-in machine.....	240	10x1½	1½
Head banding and lining machine.....	100	30x3½	2
Book deckle machine..	2000	3x3	½
Pasting machine.....	220	10x3	½
Monarch gathering machine.....	....	14x6	7½
3-16 Point Dexter folder.....	150	10x3	½
38 in. cutter, about..	325	.....	2
44 in. cutter, Sheridan	215	24x4	3
48 in. cutter, Holyoke.	250	24x4	3
Aut. knife grinder....	300	12x5½	4

**Western Electric Company to Concentrate its Manufacturing at Hawthorne**

It is officially announced that the Western Electric Company, of Chicago, will soon abandon its old Clinton Street works as well as those at Polk Street and the river, and concentrate all its manufacturing departments in Chicago at the Hawthorne Works. About \$600,000 will be spent in the construction of three large buildings and in additions to some of the buildings already erected. Some of the departments at the New York plant will also be moved to Hawthorne.

The new additions to the Hawthorne Works will make it one of the largest manufacturing plants in the country. With a ground area of 150 acres and most excellent railroad facilities for the receipt of raw material and fuel, and for the shipment of finished products, these works combine the most modern machinery and methods of manufacturing on a large and economical scale.

# The Electric Lighting System of the Washington Union Station, Washington, D. C.

THE Washington Union Station, Washington, D. C., which has just been completed, presents some very interesting problems in lighting and power requirements. The property consists of: The Union Station, said to be the largest and most magnificent railroad station in the world; Express Building, occupied by the Southern, Adams and United States express companies; power plant, locomotive and car repair shops, coach yard and several signal towers.

The power plant supplies electric current for light and power, steam for heating, compressed air for cleaning, brake testing, signals, etc., and water for drinking, house service and fire protection, to the station, express building and adjoining yards, and also light and power to the coach yard, repair shops and signal towers. Separate power plants furnish heat, compressed air and water service to the shops and coach yard.

Service connections from the power plant to the express building and station are made through a pipe subway or tunnel. Piping for water, heating and refrigerating service is carried on supports suspended along the centre line of this subway, while vitrified tile ducts, with manholes at convenient intervals, are built into the wall for the electric service.

Cables for electric service north to the coach yard, repair shops and signal towers, are carried through a line of vitrified tile ducts laid in concrete between the tracks. Concrete manholes provided with cast-iron covers are located from 250 to 300 feet apart on straight runs, and at convenient points where the duct system crosses streets. Manholes are connected to the general drainage system.

The best of materials only is used in the lighting and power systems in order that they shall be as lasting as the building construction. Conduit furnished by the Safety Armored Conduit Company, electro-galvanized both inside and outside, is used throughout, the smallest size installed being three-quarters-inch. In the inspection of conduit the specifications, with reference to weight and dimensions, were very rigidly enforced, the requirements in this respect being the same as for standard weight steam pipe. All short-radius bends were factory made and galvanizing was performed after bends were formed.

All other bends were made by hand in the field, and the heating of conduit for this purpose was prohibited.

Outlet, junction and all boxes for low-tension service are of heavy cast-iron construction. In many instances it was thought advisable to use specially designed material and apparatus in order to provide a lighting and power system in keeping with the other construction. Threaded connections, reinforced by locknuts and bushings, are used throughout between conduit and outlets in order to provide a continuously grounded system. In addition, the conduits are brought into contact with the steel framework of the buildings and at

canized rubber. These cables were subjected to and successfully withstood a test of 7500 volts for five minutes between conductors, and between conductors and ground, after being submerged in water for 24 hr. at the factory, and 5000 volts for five minutes between conductors and the ground after being installed. Insulation resistance averaged well above 150 megohms per mile. The arc cables, both four and eight-conductor, have each conductor insulated with rubber with varnished cambric over all. These were made up to withstand a test of 10,000 volts at the factory, and 8000 volts after being installed under the conditions mentioned above.



FRONT VIEW OF UNION STATION, WASHINGTON, D. C.

transformers, the neutrals of which are in every case grounded, a common ground connection is made.

The high-tension distributing system for incandescent lighting and power purposes is operated at 2300 volts and 60 cycles. Each transformer for lighting purposes and each set of transformers for power purposes is served by an independent cable direct from the switchboard at the power-house. Cables for arc service have either four or eight conductors and serve from two to four loops. All motor-driven apparatus is operated from three-phase lines, while all incandescent lighting service is taken from one phase of the generators in order to secure as good regulation as possible and to simplify the wiring.

All cables running north to the coach yards, shops and signal towers are lead-covered on account of the presence of moisture in the duct system. Those to the south are double-braided only, as the ducts in the wall of the pipe subway are reasonably dry and are protected from moisture. The single and three-phase, 2300-volt cables are insulated with varnished cambric over a thin layer of unvul-

Insulation resistance averaged about 4500 megohms per mile. All high-tension cables were furnished by the General Electric Company.

General Electric new type H transformers, with a ratio of ten to one, are used and are placed in fireproof vaults located at convenient points in the basement of the various buildings. The vault walls are of brick and are built solid from the floor to the ceiling. The floor space generally covers an area of about 100 square feet, giving sufficient room for the changing of transformers and parts without disturbing transformers in service. Vault doors are constructed of iron, lined with asbestos, and are equipped with lock and keys, and are of sufficient height and width to facilitate the removal of apparatus.

The high-tension cables in each vault terminate at a set of disconnecting switches mounted on the wall above the transformers. Expulsion type fuses are installed between the switches and transformers. Low-tension feeder distributing panels, encased in quarter-inch sheet-metal cabinets, are mounted on the outside of the vault walls at either side of the door, connection to the transformers

being made through iron-pipe conduit.

Three-wire, 113-226-volt feeders are run from the feeder cabinets to distributing cabinets, located at convenient points throughout the buildings,

called for under United States navy yard and dock specifications for low-tension wires, is used for insulating all the secondary wires. Feeders and tie lines are single-conductor and branch

into the outlet boxes. Loops from the power-house control from 25 to 37 lamps each, individual groups being controlled by Gilbert porcelain cutouts enclosed in cast-iron cases conveniently located. Solid No. 8 wire, insulated with Okonite compound and run in one and one-quarter-inch conduit is used for arc service.

All other lighting, except that in the ticket lobby, which is furnished by tungsten lamps, is furnished by metalized carbon filament lamps.

In selecting the lighting units for each particular case, careful consideration was given to the relative efficiencies, reliability and maintenance costs of all commercial lighting units, the conclusion being based upon data obtained from laboratory tests and from many installations in operation.

#### UNION STATION.

The Union station, passenger concourse, and train sheds cover a ground space of more than 18 acres. Thirty-three tracks, served by 19 platforms, enter from the north. Thirteen merge into two which continue to the south under the station and through twin tunnels running between the Library and the Capitol under First Street. The sub-basement and concourse basement are used for baggage purposes. The station basement is occupied by a portion of the ventilating and other service machinery and several transformer vaults, the balance of the space being held in reserve for future re-

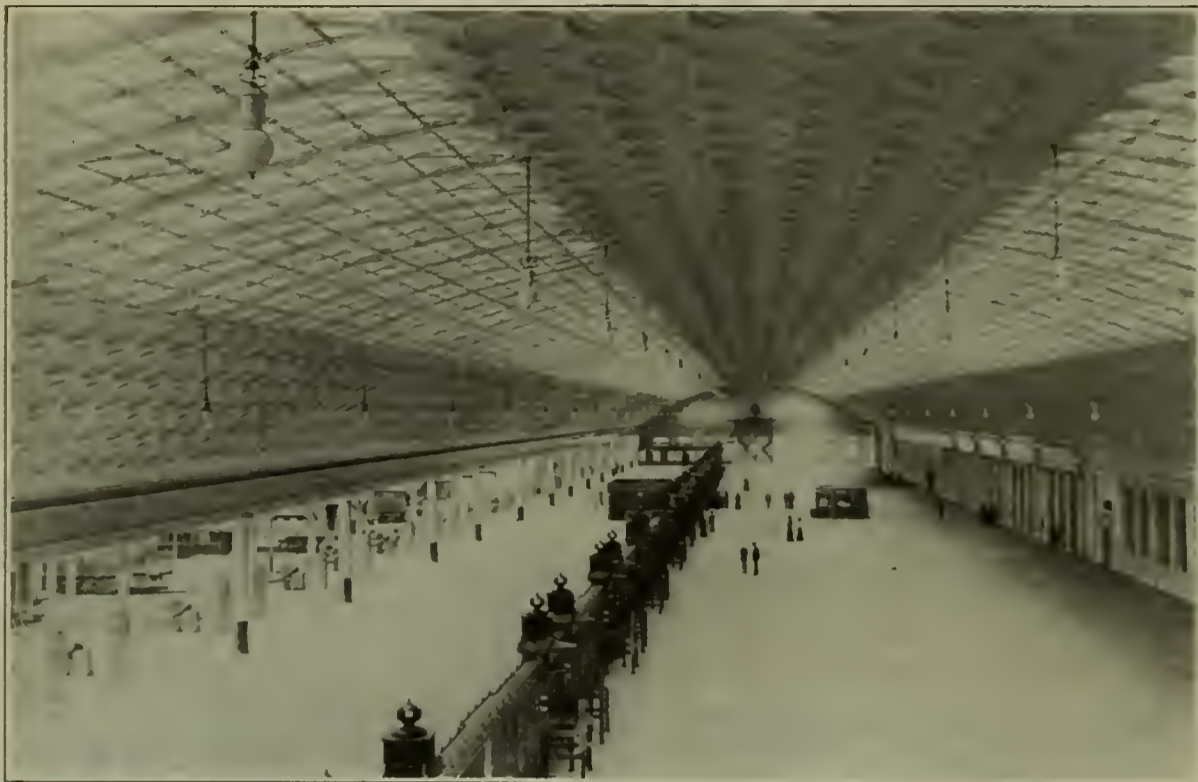

CONCOURSE LIGHTING, UNION STATION, WASHINGTON, D. C.

each feeder serving from one to five or six distributing cabinets. Distributing panels are encased in heavy sheet-metal cabinets and are equipped with three-wire busses and two-wire branches. Feeder circuits, busses and branch circuits are invariably controlled by knife switches, branch circuits being protected by plug fuses and busses and feeders by type A fuses. To secure mechanical strength, no switches smaller than 25 amperes are used on branch circuits, or smaller than 150 amperes on main circuits.

After a number of distributing cabinets had been installed a change was made in the District regulations to permit the grounding, under certain conditions, of all electric fixtures not connected to gas piping. The general scheme of wiring was accordingly changed to profit by this change in regulations. All insulating joints are eliminated entirely. The neutral wire of the branch circuits is grounded to the conduit system at both the fixture outlet and the distributing cabinet—at the latter by means of a copper wire running entirely around the panel in the wiring space and connected with each neutral wire and the conduit system. The neutral wire of feeder circuits is also grounded to the conduit system at cabinets and at transformers by means of a ground plate laid in charcoal under the vault floor. Neutral fuses in all feeder circuits are eliminated and solid copper bars substituted.

Okonite compound, of the thickness

circuits twin-conductor. No electrical tests were required prior to installing. After installing, tests for insulation resistance gave results from three to twenty times greater than called for by the District regulations.

The lighting of large floor spaces is



WEST END OF WAITING ROOM AND TICKET LOBBY, UNION STATION, WASHINGTON, D. C.

generally accomplished by the use of series direct-current arc lamps. General Electric form 10 and 11 lamps are used throughout and are suspended from cone-shaped insulators screwed

quirements. The first or street floor is occupied by the main waiting room, ticket offices, baggage room, dining and lunch rooms, women's room, smoking room and state apartments.



The kitchen is located on the second floor. The balance of the second floor, the third, and a part of the attic floors are used for office purposes.

#### MAIN WAITING ROOM.

In the preliminary design of the main waiting room it was decided to

lamps in service may be had. A series of luxometer readings were taken with all possible combinations of lamps. From the results of these tests it was found: That the corrugated reflectors and light-colored ceiling give almost perfect diffusion; that with all lights burning, at reading

daylight and gives practically true color values in every part of the spectrum. Considerable difficulty was experienced in procuring the glass used to soften the color of the light, as it is required that the glass should not absorb too much of one or all colors. By the use of the "Cathedral Glass" and clear inner globes, a loss of but 16 per cent. in the light was entailed, that being less than with an opal inner globe alone.

#### TICKET LOBBY.

The ticket lobby, located at the west end of the waiting-room, is approximately 100 ft. long by 50 ft. wide, with a barrel-shaped skylight ceiling for natural lighting in the daytime. At first the use of a system of lighting similar to that in the waiting-room, but with smaller units, was considered. A study of the conditions and tests of the glass indicated that it would be less expensive both in construction and maintenance to install individual lamps above each skylight. Tungsten lamps of 100-watt size with metal reflectors painted inside with aluminum paint are used. The lamps are arranged on four three-wire circuits, controlled by single-pole switches, so that half the lights may be cut out of service without disarranging the symmetry of the lighted panels. The illumination in this portion of the station averages about 2.3 foot-candles, the quality of the light closely approximating that in the adjoining main waiting-room and the distribution being equally as good. The reflectors used are of a special design and are so mounted as to direct the light toward the center axis of the



REAR VIEW OF REFLECTOR-FRAMES IN ALCOVE, UNION STATION, WASHINGTON, D. C.

use some system of lighting by which the fixtures and lamps would be concealed. The room covers a floor space of 120 feet wide by 230 feet long, and has a barrel-shaped ceiling of 60 feet radius, the highest point of which is about 98 ft. from the floor. A series of five alcoves, which form galleries over the entrance vestibules, run along the sides of the room, with colonnades connecting the galleries across the ends of the room. The ceiling is light in color and is decorated with gold leaf. While not elaborate, the decorations are rich and in complete harmony with the fixtures and architecture.

Banks of especially constructed inverted series arc lamps are placed in the alcoves and back of the balustrade on top of the colonnades, with corrugated mirror reflectors behind them to throw the light to the ceiling, whence it is reflected to the floor. As an aid to the reflectors, magnetic coils, which tend to draw the arc toward the waiting room, are installed on the lamps and give good results. To soften the light and reduce the bluish-white tint characteristic of arc lamps, "Cathedral Glass" screens of a very light yellow tint are placed over the lamps and reflectors.

The lighting equipment consists of a total of 162 lamps so arranged that several combinations in the number of

distance from the floor, about 42 in., the illumination is practically uniform, the curves both north and south, and east and west being nearly a straight line, and the values varying from 2.5 foot-candles in the corners of the room to 2.3 foot-candles in the centre,



TRAIN SHED LIGHTING, UNION STATION, WASHINGTON, D. C.

thus making the use of auxiliary lighting on the seats for reading purposes not only unnecessary but out of harmony in color and arrangement with the general scheme employed. The light is a very close approach to

arch. There are in all 225 lamps above the skylight, all being in a pendent position. A very small percentage of the light passes up, the major portion being directed down into the lobby below.

BAGGAGE ROOM.

The baggage-room on the first floor is lighted during the daytime by 17 saw-tooth skylights through a ceiling of maze glass panels. For artificial illumination one arc lamp is placed above each ceiling panel with good results. Each lamp is equipped with a large reflector. The skylight tile-work has also been painted white with most pleasing results. The effect has been to destroy shadows and color rings, to smooth out and enlarge the distribution of the light, to make the color more mellow and in harmony with that in the adjoining ticket lobby, to direct all the light downward and to reduce the annoying effects of flicker-

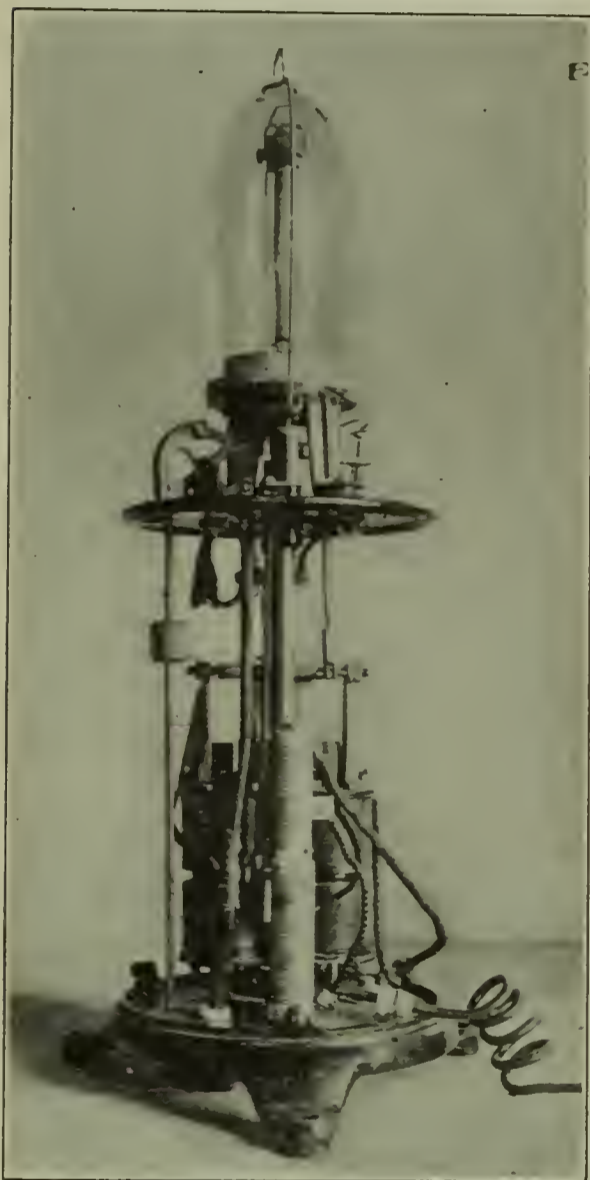

INVERTED ARC LAMP, CASING REMOVED.

ing, arc traveling and feeding. The illumination in this room averages about 1.8 foot-candles and is both comfortable and sufficient for the work performed.

CONCOURSE.

The concourse occupies a space of 755 ft. long by 150 ft. wide between the station building and train shed. It serves as a means of passage to and from trains and is lighted entirely by arc lamps suspended about seven feet from the ceiling. At this distance from the ceiling the lamps cast very

slight shadows overhead. The absence of pronounced shadows is desirable on account of the paneling in the ceiling. It was attempted experi-

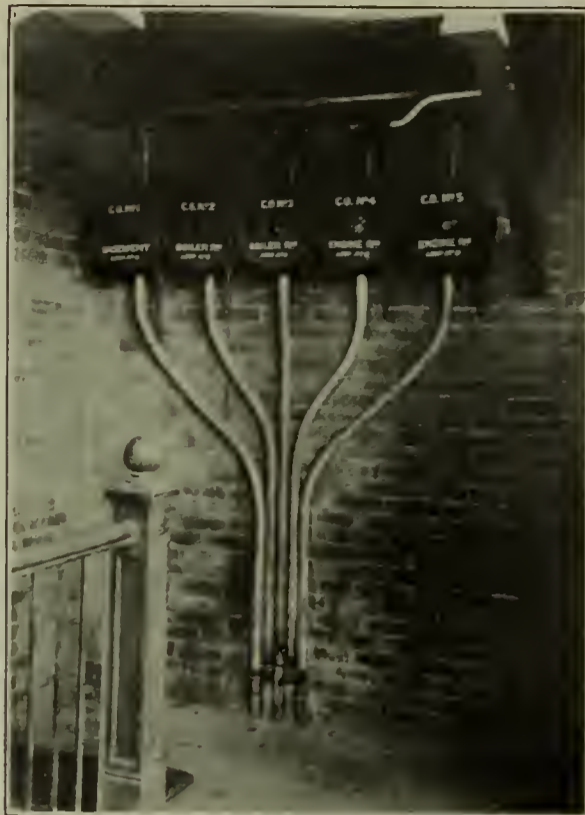

ARC CUTOUTS WITH CONDUIT CONNECTIONS.

mentally to light this space by placing arc lamps between the roof and ceiling over the skylights. The scheme was condemned principally on account of the steelwork supporting the roof casting very pronounced shadows on the skylights, and because the glass used has a very large absorption fac-

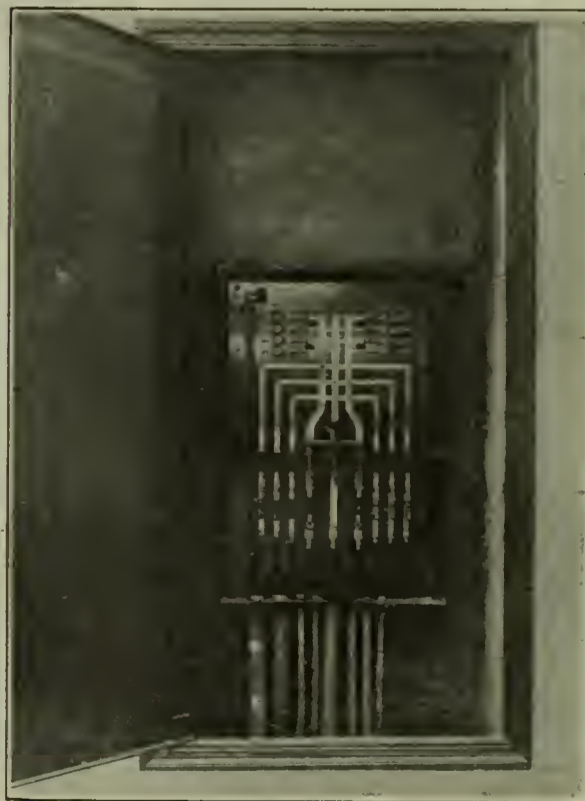

TYPICAL DISTRIBUTING PANEL AND CABINET.

tor and is not uniform in color when lighted artificially. Series direct-current arcs did not give good results on account of the great loss due to absorption. Flaming arcs, by reason of their great quantity of light, gave

good results, but were abandoned because of their pronounced yellow color being out of harmony with the general color values in other parts of the station and the high cost and difficulty of maintenance in the positions they occupied. Other experiments were also made in an effort to reduce the total number of units used, by employing large diffusers containing four and five units each. This, however, gave the effect of large units of high intrinsic brilliancy and was for that reason abandoned. It also produced objectionable streaks and shadows on the ceiling. This system would undoubtedly have worked out well had the ceiling been designed so as to have the diffusers set in it instead of below it. The reasons for abandoning this system were due to the original layout not conforming to its use and not to any faults in the diffusers themselves. With the diffuser installation the illumination on the floor was sufficient, pleasant and well diffused, the streaks and shadows on the walls and ceiling being due to the non-conformity of the building design and the necessary method of installation. Each lamp is equipped

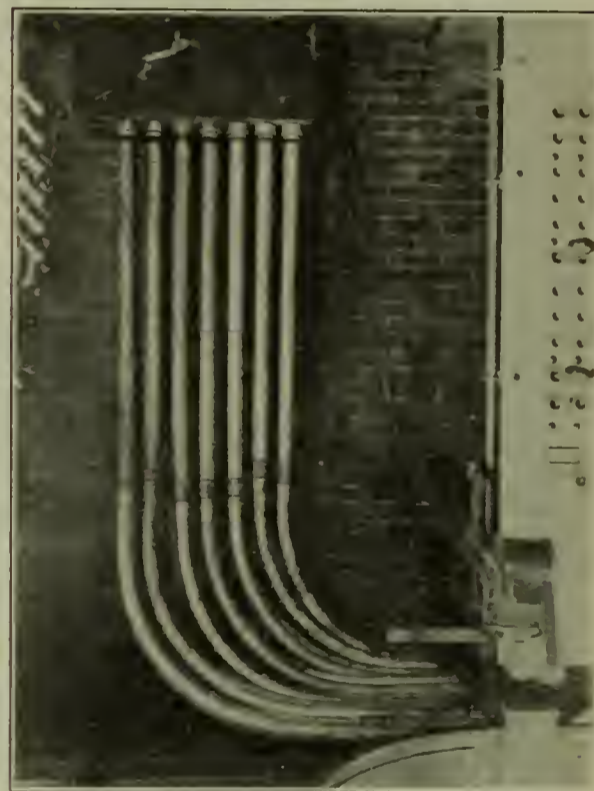

CONDUIT IN POWER-HOUSE.

with a clear inner and opal outer globe and the quality and distribution of the light is as good as could be desired. Means have been provided for a suitable casing to cover the wires and insulator directly above the lamp, and a canopy to improve the appearance at the ceiling outlet. A collapsible and movable extension ladder is used in trimming these lamps.

MISCELLANEOUS.

The lighting of the offices is uniform in design. One and three-light fixtures finished in dull black are used.

The sockets are arranged for vertically suspended lamps, permitting the use of Tungsten lamps at some future date, and for Holophane shades.

The train platforms are covered by umbrella sheds supported on cast-iron columns spaced 30 ft. apart along the centre line of the platform. One hundred and eighty-seven-watt Gem lamps, equipped with Holophane bowl reflectors, are suspended midway between the columns from especially designed outlet boxes attached to the steelwork of the roof. These give

POWER REQUIREMENTS SOUTH OF M STREET.	
	Total watts.
Small motors at station.....	225,000
Train tunnel fans.....	250,000
Battery charging motor generator.....	50,000
Motors, power plant and K street tower....	120,000
<b>Total.....</b>	<b>645,000</b>

abundant light for loading or unloading trains and are readily accessible for renewals. They may, however, be changed to 100-watt Tungsten lamps later with the desirable results of increasing the quantity of light and decreasing the total energy used.

The ventilating fans are operated from 226-volt, three-phase service and the dumb-waiters from 113-volt, direct-current, from a 10-kw. motor generator set. The total load is small and is carried by three 75-kw. transformers connected in delta.

POWER-HOUSE.

The larger floor spaces in the power-house are lighted by arc lamps, while the smaller machinery passage ways and offices are lighted by Gem lamps equipped with Holophane reflectors. The fixtures, as a rule, are made of one-half-inch conduit instead of three-eighths-inch and without ornamental tubing on the outside. This arrangement gives a very strong and serviceable fixture. A multiplicity of extension-plug outlets is provided, extension cords equipped with Frink lamp guards and Fullman plugs being supplied.

All the electrical work above described was installed by A. S. Schulman, of Cincinnati, Ohio. Credit is due I. R. Prentiss, of the General Electric Company, for many valuable suggestions in connection with the lighting of the waiting-room and other important portions of the station. W. D'A. Ryan, of the illuminating department of the same company, also gave valuable assistance in this direction.

The tabulation on the opposite page gives an itemized statement of the kinds of lamps used, method of lighting and wattage per square foot for floor space throughout the buildings described in this article.

WASHINGTON TERMINAL LIGHTING SYSTEM.						
UNION STATION.						
	Sq. Ft.	Watts per Sq. Ft.	Total Watts.	System.	Kind of Lamp.	
Sub-basement.....	9,420	0.58	5,500	Direct.	D.-c. series arcs.	
West basement.....	36,864	1.75	64,600	Direct.	D.-c. series arcs.	
East basement.....	6,352	1.88	12,000	Direct.	Arcs and GEM.	
Ticket lobby.....	5,200	4.25	22,500	Concealed above glass ceiling.	100-watt tungsten.	
Ticket office.....	1,536	2.05	3,150	Direct and concealed.	GEM.	
Baggage room.....	5,236	1.66	8,500	Concealed above glass ceiling.	D.-c. arcs.	
Main waiting room.....	28,320	2.93	83,000	Indirect.	Inverted d.-c. series arcs.	
Booth and special lighting main waiting room.....			2,000	Special.	GEM.	
Smoking room.....	1,876	2.24	4,200	Direct.	GEM.	
Barber shop.....	612	1.97	1,200	Direct.	GEM.	
Toilets.....	1,818	0.87	1,640	Direct.	GEM.	
Telephone space.....	508	2.26	1,150	Direct.	GEM.	
South vestibule.....	957	2.82	2,700	Direct.	GEM.	
Drug store.....	320	3.43	1,100	Direct.	GEM.	
Parcel room.....	384	2.81	1,080	Direct.	GEM.	
North vestibule.....	2,320	2.58	6,000	Direct.	GEM.	
East colonnade.....	320	3.28	1,050	Direct.	GEM.	
Women's waiting room.....	2,720	1.54	4,200	Direct.	GEM.	
Women's toilet.....	1,280	0.78	1,000	Direct.	GEM.	
Dining room.....	7,488	1.73	13,000	Direct.	GEM.	
Lunch room.....	8,352	1.34	11,200	Direct.	GEM.	
Steward's office.....	300	1.00	300	Direct.	GEM.	
Serving room.....	4,352	0.71	3,100	Direct.	GEM.	
State entrance porch.....	2,560	1.09	2,790	Direct and concealed.	GEM.	
Vestibule state entrance.....	720	5.20	3,750	Concealed.	Incandescent.	
President's reception room.....	2,584	1.38	3,600	Direct.	GEM.	
President's retiring room.....	224	2.67	600	Direct.	GEM.	
Attendants' retiring room.....	224	2.67	600	Direct.	GEM.	
Invalids' room.....	352	1.42	500	Direct.	GEM.	
East driveway.....	9,600	0.52	5,000	Direct.	D.-c. series arcs.	
East portico.....	1,344	1.76	2,400	Direct.	GEM.	
South portico.....	7,680	0.52	4,000	Direct.	GEM.	
Main entrance porticos.....	5,544	1.83	10,150	Direct.	GEM.	
Carriage porch.....	11,744	0.84	9,900	Direct.	GEM.	
Concourse.....	98,800	0.37	37,000	Direct.	D.-c. series arcs.	
Concourse news stand.....	169	10.94*	1,850	Direct and special.	GEM.	
Concourse ticket office.....	968	1.39	1,350	Direct.	GEM.	
Concourse fire department and toilet	572	1.04	600	Direct.	GEM.	
Station master's office.....	1,147	0.98	1,125	Direct.	GEM.	
Stairways to tracks.....	800	1.87	1,500	Direct.	GEM.	
Umbrella sheds.....	397,440	0.092	82,000	Direct.	GEM.	
Train gates.....			15,000	Special.	GEM.	
Massachusetts avenue tower.....	384	2.08	800	Direct.	GEM.	
East portion second floor.....	23,728	1.08	25,650	Direct.	GEM.	
West portion second floor.....	16,032	0.91	14,600	Direct.	GEM.	
East portion third floor.....	19,968	1.20	24,000	Direct.	GEM.	
West portion third floor.....	9,276	1.19	11,100	Direct.	GEM.	
East portion attic.....	16,652	0.57	9,600	Direct.	GEM.	
West portion attic.....	17,472	0.20	3,500	Direct.	GEM.	
Floor outlet.....			30,000			
<b>Total lighting load.....</b>			<b>557,135</b>			
* Includes show-case lighting.						
EXPRESS BUILDING.						
	Sq. Ft.	Watts per Sq. Ft.	Total Watts.	System.	Kind of Lamp.	
Offices.....	25,080	1.34	33,000	Direct.	GEM.	
Distributing space and offices.....	25,080	0.76	19,000	Direct.	GEM and arcs.	
Storage space basement.....	25,080	0.78	19,500	Direct.	D.-c. series arcs.	
Driveways.....	33,880	0.33	11,200	Direct.	D.-c. series arcs.	
Train shelters.....	26,670	0.42	11,200	Direct.	D.-c. series arcs.	
Plug receptacles.....			5,610			
<b>Total.....</b>			<b>99,510</b>			
K STREET SIGNAL TOWER.						
	Sq. Ft.	Watts per Sq. Ft.	Total Watts.	System.	Kind of Lamp.	
Offices.....	3,630	0.60	2,200	Direct.	GEM.	
Basement.....	1,800	0.42	756	Direct.	GEM.	
Small motors.....			15,000			
<b>Total.....</b>			<b>17,956</b>			
INSPECTORS' BUILDING.						
	Sq. Ft.	Watts per Sq. Ft.	Total Watts.	System.	Kind of Lamp.	
Store room and lunch room.....	4,158	1.20	5,000	Direct.	GEM.	
Offices.....	4,158	1.33	5,500	Direct.	GEM.	
Basement.....	4,158	0.61	2,500	Direct.	GEM.	
<b>Total.....</b>			<b>13,000</b>			
POWER PLANT.						
	Sq. Ft.	Watts per Sq. Ft.	Total Watts.	System.	Kind of Lamp.	
Boiler room.....	7,800	1.63	12,716	Direct.	Arcs and GEM.	
Engine room.....	9,000	1.22	11,000	Direct.	D.-c. series arcs.	
Plug receptacles.....			28,050			
<b>Total.....</b>			<b>51,766</b>			
REFRIGERATING PLANT.						
	Sq. Ft.	Watts per Sq. Ft.	Total Watts.	System.	Kind of Lamp.	
Attic.....	1,050	0.76	798	Direct.	GEM.	
Second story.....	1,050	1.42	1,500	Direct.	GEM.	
First floor.....	1,050	1.27	1,350	Direct.	GEM.	
Basement.....	1,050	1.85	2,000	Direct.	GEM.	
<b>Total.....</b>			<b>5,648</b>			
Pipe tunnel.....			2,500	Direct.	Incandescent.	
Train tunnel.....			10,000	Direct.	Arcs and incandescent.	
SUMMARY.						
Total connected lighting load south of M street.....			757.5 kilowatts			
Total connected power load south of M street.....			645.0 kilowatts			
<b>Total.....</b>			<b>1,402.5 kilowatts</b>			

# The Kokomo, Marion & Western Traction Co.

C. A. TUPPER

The new power station of the Kokomo, Marion & Western Traction Co. has recently been equipped with two Allis-Chalmers steam turbines and generators having an aggregate normal capacity of 2000 kw. and delivering two-phase, 60 cycle current at a terminal pressure of 2300 volts. The first of these machines, put in operation February 21, 1907, was found so satisfactory that a second unit of identical construction was ordered, the latter being placed on the line December 7th of the same year.

## COAL HANDLING SYSTEM

Coal, consisting of a comparatively low grade of Indiana screenings, is brought in on a spur from the Lake Erie & Western Railway and unloaded through a trestle extending the entire length of the firing room, so that it is heaped up in front of iron doors opening upon the several furnaces. From these piles it is shoveled directly into the furnaces, which are so arranged as to obtain a relatively high heat value from the fuel. Removal of ashes is accomplished by an inexpensive device. Instead of the customary ash-pit with track and cars, there has been installed a tunnel and screw conveyor through which the ashes are constantly transferred to a pit outside the building. There, by means of a bucket elevator and inclined conveyor, the material is discharged to storage bins at one side of the building and unloaded into cars, which take it to points along the line where it can be used as ballast.

## BOILERS AND STACKS

The boiler equipment, set on concrete foundations reaching to bed rock, consists of three batteries, two of which include four Stirling boilers, each having a capacity of 235 h.p., and the third comprising one Atlas water-tube boiler with a capacity of 400 h.p. Two of the Stirling boilers discharge into one stack 6 by 80 ft., constructed entirely of steel, and the remaining two, with the Atlas boiler, into a stack 6 by 125 ft., also of steel. The shorter of these stacks is equipped with an engine-driven blower, made by the Sturtevant company, by means of which enough draft can be induced to give large temporary overload capacity to the two boilers

with which it is connected. The boiler room has ventilators at the top and is very commodious, with room for considerable additional capacity.

## STEAM HEADER AND PIPING.

A main steam header 12 inches in diameter, located above the pump compartment in the steam turbine room, is in the form of a loop, from which each turbine unit is fed by a 7-inch pipe. Gate valves are placed between each battery of boilers and between each turbine inlet, these valves being of the Crane type with rising stems. There is also a 4½-inch auxiliary header. A proper arrangement of valves enables any part of the plant to be supplied from any boiler at will. All of the piping is made as short and direct as possible and heat insulation is provided in the shape of heavy covering of the pattern furnished by the

feeds by gravity into the heater and from there by gravity into the boiler feed pumps; or the water may be bypassed directly to the boiler.

Two Worthington pumps are used for supplying the tank over the heater and two Dean pumps for boiler feed. Either one of these two is, however, of sufficient capacity to take care of the water system of the entire plant. The former are now being displaced by a centrifugal pump with 2½-in. discharge, driven by an induction motor supplied with current directly from the main generator busses through a step-down transformer; but the steam pumps will be held in reserve.

## WATER SUPPLY.

Water for condensation and boiler feed is taken from a creek, about 350 ft. distant, through a 16-in. cast-iron pipe, and discharged back to the



MAIN POWER STATION OF KOKOMO, MARION & WESTERN TRACTION CO.

Johns-Manville Company. Long bends to provide for expansion have, of course, been used wherever necessary, and the system includes Cochrane steam separators.

## FEED WATER HEATER AND PUMPS.

The condensers and all of the other auxiliaries exhaust into a Cochrane heater (with Sorge water purifier), where a temperature of from 200° to 212° fahr.—never less than 200°—is constantly maintained. Water may be drawn from either the condenser suction or discharge pipes, from a deep well or from the city mains, and discharged into an elevated tank which

steam through a 20-in. tile. The water is drawn from a concrete basin in the creek, 7 ft. square inside and extending 6 ft. below low-water mark, with walls extending to high-water mark and a gate on the down-stream side where the water enters. This gate can readily be closed down tight, when desired, and the water exhausted by pumps in the power plant, so as to facilitate cleaning the basin of sand and mud.

## STEAM TURBINES.

The turbine operating floor is 5½ ft. above the boiler and pump-room floor, 11 ft. above the basement floor

and 30 ft. below the roof trusses, the foundation of each generating unit being kept entirely separate from the steel frame of the concrete flooring. Overhead is a 10-ton crane, hand operated.

In this room are placed two horizontal steam turbines and generators of 1000-kw. capacity, a 330-kw. engine-driven alternator operated in parallel with them, the exciters for these units, and substation apparatus, transformers, switchboard, etc., as later described.

These turbines have the various patented features of the Allis-Chalmers Company, among which may be mentioned channel-shaped shrouds protecting the ends of the blading from injury; machine-cut slots in the foundation rings insuring accurate spacing of the blades; a method of fastening the latter which effectually prevents them from working loose, and improved balance pistons. Other details of special interest will be mentioned briefly under the subjects to which they belong.

The turbines operate at 1800 rev. per min., with a steam pressure of 140 lbs. at the throttle, dry saturated, and a vacuum of 28 in. of mercury referred to 30-in. barometer at the exhaust nozzle. Large temporary overload capacity has been provided for in the design of these machines; high efficiency is maintained and close regulation secured, even under the most unfavorable operating conditions, as a result of good design and efficient station management. They are frequently run six weeks at a time without taking the load off, and then only to make inspection.

BEDPLATE.

The bedplate is divided into two parts, one carrying the low-pressure end of the turbines and the bearings of the generator, and the other the high-pressure end of the turbine. The turbine is secured to the former, while the latter is provided with guides which permit the turbine to slide back and forth with differences of expansion caused by varying temperature, at the same time maintaining the alignment. This arrangement permits of the utilization of the entire space between the foundation piers and below the turbine for the condensing apparatus. A grating is provided in the engine-room floor directly over the condenser pumps and engines, so that operators above and below can watch each other's movements and signals, and the auxiliary engines can ordinarily be watched from above.

CONDENSERS.

The condensers for the steam turbines are of the jet type built by

the Allis-Chalmers Company, each capable of giving the best possible service when its unit is operating at full-rated load. Cycloidal air pumps, direct-connected to enclosed, self-oiling, high-speed engines, and duplex, double-acting circulating pumps are installed with this apparatus, as is also a third condenser to take the exhaust from the remainder of the plant.

GOVERNING MECHANISM.

The speed of each turbine is regulated within close limits by a governor driven from the shaft through cut gears working in an oil bath. This governor, by means of a relay, operates a balanced throttle valve. The entire mechanism is so proportioned as to respond at once to variation of load, but its sensitiveness is kept within such bounds as to secure the best results in the parallel operation of the two turbo-generators in this station. The governors can be adjusted for speed while the turbines are running, thereby facilitating the synchronizing of the alternators and dividing the load as may be desired. In order to provide for any possible accidental derangement of the main governing mechanism, there is an entirely separate safety or overspeed governor. This governor is driven directly by the turbine shaft without the intervention of gearing, and is so arranged and adjusted that if the turbine should

reach a predetermined speed above that for which the main governor is set, the safety governor will come into action and trip a valve, shutting off the steam and stopping the turbine.

LUBRICATION.

The lubrication of the four bearings, two for the turbine and two for the generator, is effected by supplying an abundance of oil to the middle of each bearing by means of a small cycloidal pump driven from the turbine shaft, and allowing it to flow out at the ends. The oil is passed through a tubular cooler with water circulation, and pumped back to the bearings.

It is not necessary to supply the bearings with oil under pressure, but only at a head sufficient to enable it to run to and through the bearings,

this head never exceeding a few feet. The oil-cooling system is taken care of by two induction motor-driven centrifugal pumps, supplied by Thomas & Smith, of Chicago, and the American Well Works, and the gland water for the turbines is also supplied by two centrifugal pumps purchased from the former company, propelled by direct-current motors taking their power from the exciter circuits. No oil of any kind is used in the interior of the Allis-Chalmers steam turbines, nor in the glands through which their shafts pass. Low-oil alarms have been provided for the turbines.

LAGGING.

The hot parts of each turbine, up to the exhaust chamber, are covered with an ample thickness of non-conducting material and lagged with planished steel so applied that it may be easily removed. The non-conducting covering is also removable at the cylinder joint to facilitate the opening of the turbine for examination.

COUPLING BETWEEN TURBINE AND GENERATOR.

Between the turbine and its generator a special type of flexible coupling is used to provide for any slight inequality in the wear of the bearings to permit axial adjustment of the turbine spindle, and to allow for differences in expansion. This coupling is so made that it can be readily dis-

connected for the removal of the turbine spindle or of the revolving field of the generator. Provision is made for ample lubrication of the adjoining faces of the coupling.

TURBO-GENERATORS.

The revolving-field alternators driven by these turbines are of Allis-Chalmers Company's standard type, designed for high efficiency and safe operation at high peripheral speeds. Some of the principal advantages embodied in their construction are summarized as follows:

ROTOR.

The field core is built up of steel discs, each in one piece, giving high magnetic permeability and great strength. Coils are placed in radial

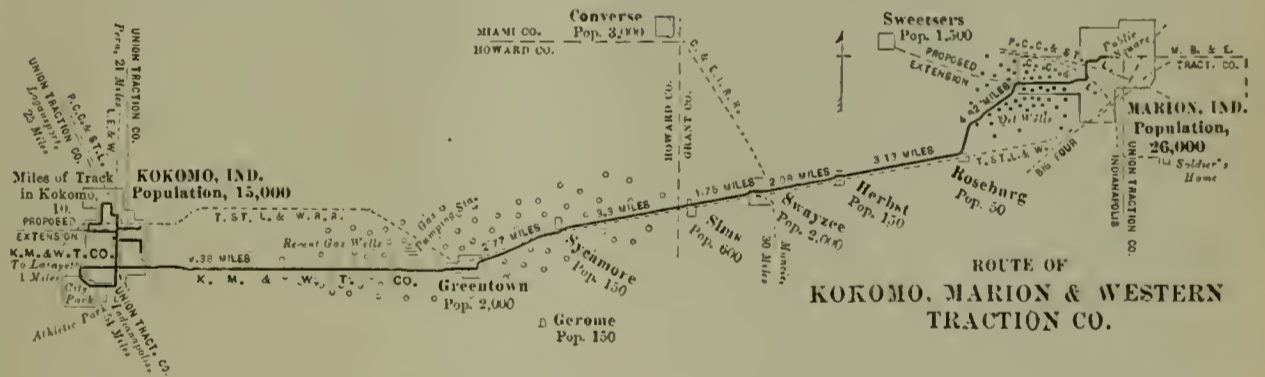

slots, thereby avoiding side pressure on slot insulation and the complex stresses resulting from centrifugal force, which, in these rotors, acts normal to the flat surface of the strip windings. Bronze wedges hold the coils firmly in the slots, making the surface of the rotor a smooth cylinder, reducing windage losses and insuring quick operation; the end connections are securely held by chrome-nickel steel rings.

#### STATOR.

The stator is completely inclosed, eliminating noise of operation. Coils were completely wound and insulated before being placed on the core, thus obviating the risk of defective ventilation. Stator windings are placed in open slots, rendering the coils readily removable. End connections are firmly braced, preventing deformation of coils in case of short-circuit.

#### VENTILATION AND MUFFLING.

For the purpose of obtaining adequate ventilation and for muffling the noise produced by the circulation of the air, the turbo-generators are enclosed in such a manner that the air is taken in at the sides through fans mounted on the rotor shaft which discharge it over the end connections of the armature coils into the bottom of the machine, whence it passes through the ventilating ducts of the core to an opening at the top. This system of ventilation is most efficient.

#### EXCITERS.

Excitation of the two turbo-generators is accomplished by means of exciters of 35 kw. and 30 kw., the former being driven by an Allis-Chalmers induction motor and the latter by an Erie Ball engine. The engine-driven unit has a 5-kw. belted exciter. Turbo-generator excitation at full load is at 120 volts, 160 amperes. The exciters do not take care of the station lighting. Current for this is derived directly from the main bus bars, or from a storage battery.

#### STATION LOAD.

As above intimated, the character of the load put upon this station is railway, lighting and power combined. At present there is a normal consumption of current somewhat under the rated capacity of the turbines, so that one can be held constantly in reserve, and this drops to a minimum, during the early morning hours, of about 300 kw.

A feature to be particularly commended is the thorough keeping of station records and the frequent checking of efficiencies of different parts of the plant. On the Company's log-sheet the daily load curve is plotted, thereby enabling it to be easily comprehended for the 24 hours at a glance.

All costs and station performances are also recorded on the daily log. In addition to this records are kept in the office of the outside distributing circuits, and two Wright demand meters are constantly used to check the loads on lighting and power transformers over the town.

Alternating current is generated at two-phase 2300 volts, and transformed to three-phase 11,000 volts for transmission over the line of the interurban railway. In the main station there are used for this purpose three 150-kw.

rubber insulation. The wiring from the generators to the switchboard is open-work, fastened to the under side of the engine-room floor. The bus-bar system is in duplicate. Any machine or any feeder can be operated off of any set of busses. The switchboard rests on insulated stringers.

#### SWITCHBOARD.

Each of the panels for the turbo-generators has instruments mounted upon it as follows:

Two Westinghouse ammeters,

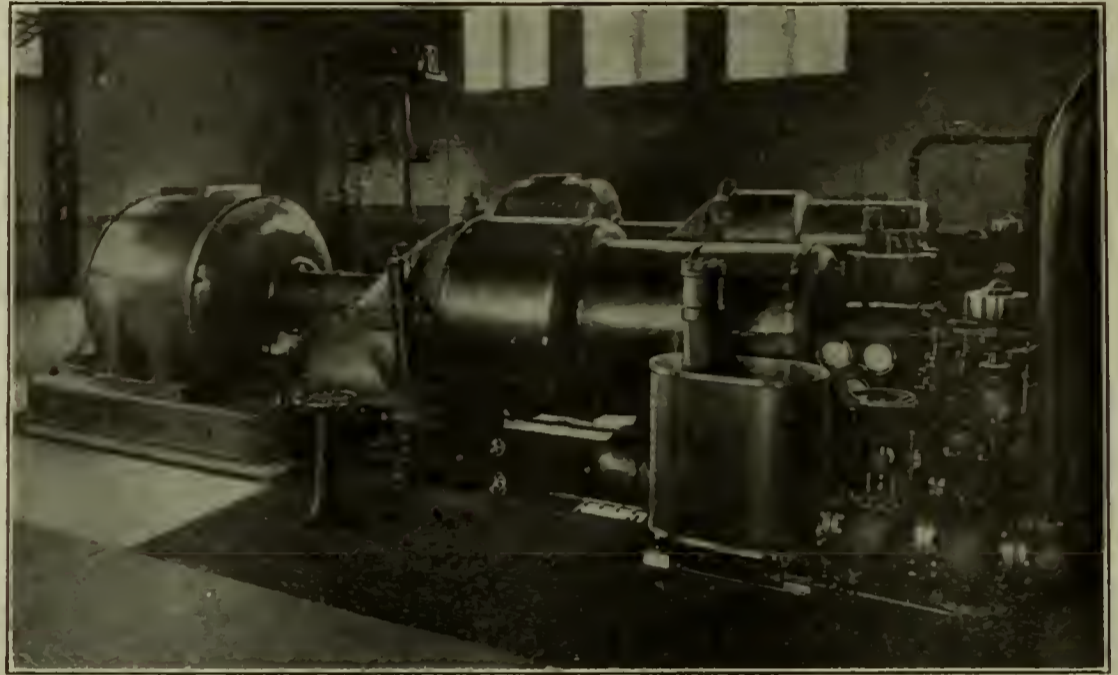

TWO 1000-KW., 1800 REV. PER MIN., 60-CYCLE, ALLIS-CHALMERS STEAM TURBINES AND GENERATORS INSTALLED IN POWER-HOUSE OF KOKOMO, MARION & WESTERN TRACTION COMPANY, KOKOMO, IND.

oil-filled, self-cooled transformers, Scott connected, and in the substation (17 miles distant) there are three 150-kw. step-down transformers delta connected. These transformers have 1½-in. outlet pipes run directly through the floor, so that in case of fire oil can be emptied into barrels in the basement where the oil supplied is stored.

Direct current for the city railway system and ten miles of the interurban line is supplied through motor-generator sets in the main station, delivering power at an operating pressure of 600 volts; and the substation at Swayzee, 18 miles east of Kokomo, contains three rotary converters for the purpose of transforming the alternating to direct current. One of these, having a capacity of 200 kw., is equipped with an induction starting motor and two of 75 kw. each, are started through a storage battery from the direct-current end.

#### DISTRIBUTION OF CURRENT.

Current from the main generator bus bars passes to the out-going lines through double-throw switches, ammeters, wattmeters and fuses, all such circuits being also put through integrating wattmeters; 300,000 circular mil cable is used, with high-voltage

One Westinghouse power-factor indicator,

One Westinghouse volt-meter,

One Westinghouse indicating wattmeter,

One Westinghouse polyphase integrating wattmeter.

Two four-pole single throw oil switches for main generator current,

One Cutler-Hammer rheostat located beneath the floor and driven by chain and sprocket.

One field knife switch with discharge rheostat synchronizing plug and receptacle and volt-meter plug and receptacle.

There is also a Westinghouse synchroscope on a swinging bracket at the end of the switchboard.

The exciter switch-panel for the turbines has:

Two direct-current Weston ammeters,

One direct-current Weston volt-meter,

Two Cutler-Hammer rheostats,

Two single-pole knife switches,

Four four-pole double-throw Westinghouse oil switches.

The exciter panel for engine-driven unit consists of the following apparatus:

Two Stanley ammeters,

One Stanley volt-meter so arranged

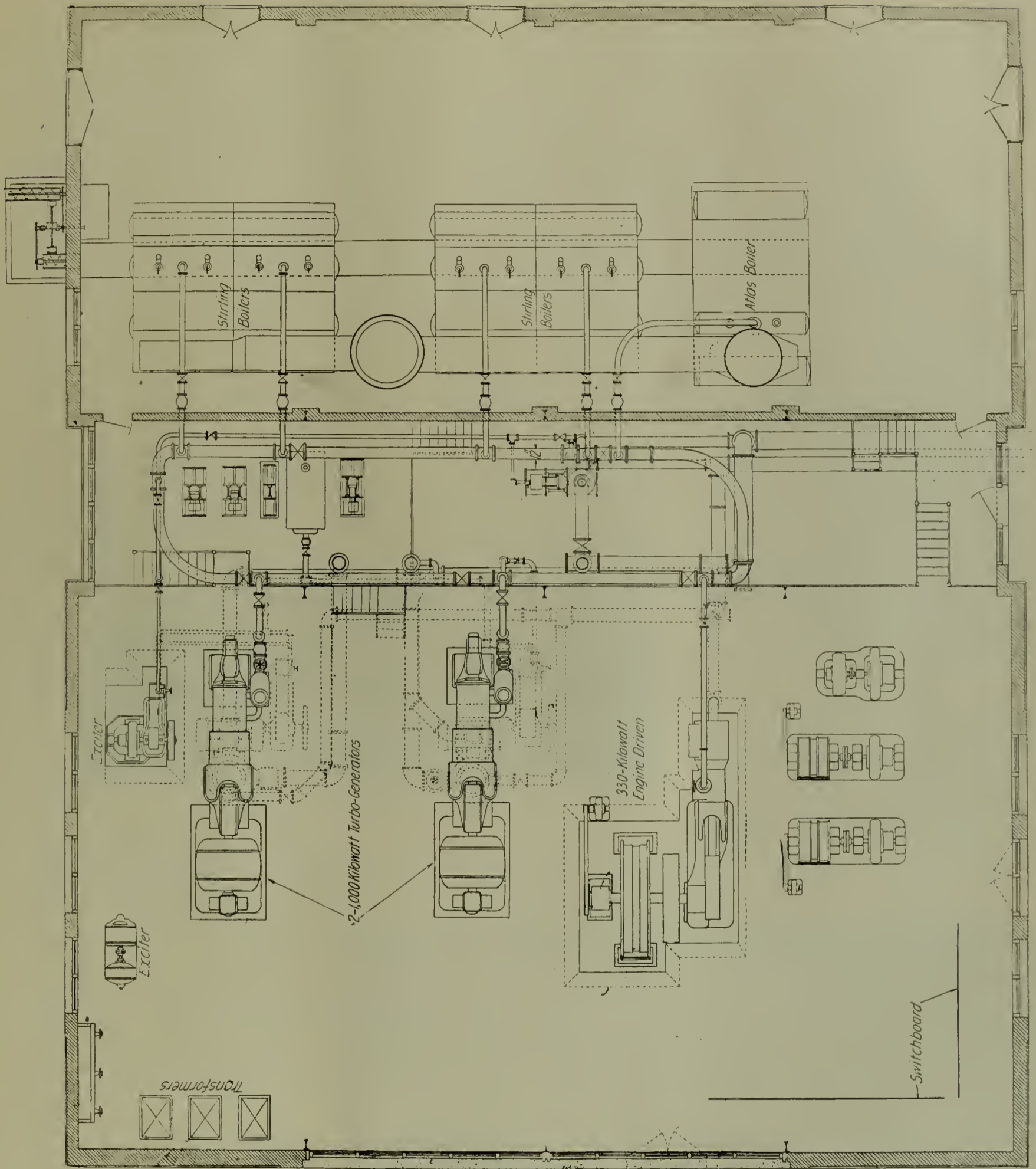

PLAN OF POWER STATION.

as to switch it on to pressure tap showing voltage at center of distribution up-town,

Two double-pole knife switches, Wirt rheostat.

One panel for the engine-driven unit is equipped with Stanley instruments and double-throw switches.

One panel with Stanley instruments and switches controls four feeder circuits.

One panel controls one feeder circuit, with room for an additional circuit. This has Westinghouse four-pole double-throw oil switches and General Electric wattmeters.

One panel controls four street arc-light circuits on the Western Electric system.

The railway board consists of two panels, each controlling a 216-h.p. motor, and two panels each controlling

the railway generators driven by these motors in the power plant substation. One panel contains the starting devices and a rheostat for these machines. There are also two feeder panels, one feeding the interurban line and the other on the city line. This railway board is equipped with Westinghouse apparatus, except for a few General Electric wattmeters and two Stanley phase indicators.

Two panels control a storage battery and differential booster.

In the substation at Swayzee there is a switchboard consisting of nine panels, viz.: three alternating current and three direct current for controlling the rotary converters, one feeder panel and two storage battery panels.

#### STORAGE BATTERIES.

In a separate building, located about 60 ft. from the main generating station, is a battery installation supplied by the Electric Storage Battery Company, which has a capacity of 480 ampere-hr. and consists of 288 chloride accumulator cells. A smaller storage battery, consisting of the same number of cells, but having a capacity of 320 ampere-hr., is installed in the substation at Swayzee. The latter has glass coils and the former are of wood with lead lining. The function of these batteries is to eliminate load fluctuations on the rotary converters, so that their output will be constant. Regulating boosters are installed in conjunction with each battery of such design as to automatically regulate the charge and discharge of the battery, causing it to discharge when the load is in excess of the average and charge at times when the load is less than the average.

#### LINES.

Alternating current passes from the switchboard bus bar through the transformers, as above mentioned. Stick breakers are provided between the high-tension sides of the transformers and the outgoing lines, which are led through high-voltage bushings protected by round glass plates set in tile.

#### LIGHTNING ARRESTERS.

The lines are equipped with Westinghouse low-equivalent arresters and Westinghouse choke coils, to which ready access is had from the gallery. The lighting feeders have General Electric lightning arresters and choke coils manufactured at the station. On the direct-current railway system Garton lightning arresters are used, there being four of these to every mile. Wirt lightning arresters are provided at each transformer on the lighting circuit.

#### EQUIPMENT OF RAILWAY SYSTEM.

The line of the interurban road is built with easy curves and a maximum grade of no more than two degrees, most of the track being laid on the level. The right-of-way is 40 ft. wide and owned entirely by the Company; 70 lb. A. S. C. E. rail is used, joined by six-bolt standard splice bars.

The bonds are of the Ohio Brass Company's manufacture and consist of No. 0000 compressed bonds and

soldered bonds on the interurban line and No. 00 compressed bonds on the city tracks. Rails are cross-bonded every half mile with No. 0000 copper wire.

The road is ballasted with crushed stone and gravel six inches deep underneath the ties, 1000 cu. yd. of stone and 300 cu. yd. of gravel being used to the mile. The ties are of white oak. Side-arm construction has been used for the entire course of the line, cedar poles being placed along ten miles of the interurban system, chestnut poles on the remaining 18 miles and cedar and iron poles in the city. The brackets are 9 ft., with 1½-in. tubing made by the Ohio Brass Company. The lightning arresters, four to the mile, are grounded by means of No. 4 copper wire and ¾-in. iron rods driven into the ground by the

compartment, having comfortable arm-chairs arranged along the sides, and the remainder has aisle seats nicely upholstered. Direct telephone connection can be opened at any time between the cars and the train dispatcher's office by a pole-and-hook connection operated in accordance with a Stromberg-Carlson system. The city cars, built by the Cincinnati Car Company, are 22 in number, each having two 40-h.p. 92 A motors and K-10 controller. Some of them are equipped with air-brakes.

#### CAR BARN AND REPAIR SHOPS.

In the city of Kokomo there is a car barn 150 by 50 ft., with four tracks and a pit underneath the entire length of one. The repair shop adjacent to this is 45 by 70 ft. and contains two tracks, one having a pit 60 ft. long be-



SUBSTATION AT SWAYZEE, IND.

side of the pole and also connected to the rail. The wires consist of two No. 000 trolleys suspended by the Ohio Brass Company's type D hangers. The feeder wires are 300,000 and 500,000 cir. mil copper line feeding on to the interurban wires 10 miles from the power station. The feeder from the substation is stranded aluminum equivalent to 300,000 cir. mil copper. Spans are 100 feet in length.

#### CARS.

The interurban cars operated on the road at an average speed of 25 miles per hour are of the Jewett Car Company's build, equipped with four 50-h.p. 93 A motors, K-28 controller and straight air-brake apparatus. There are six passenger cars of this type, with one freight car and one work car. Cars are run on one hour headway, only three being ordinarily in service at the same time. Inside they are fitted with every modern convenience, including overhead bundle racks, Peter Smith hot-water heaters, toilet-rooms and lights of high candle-power. About two-fifths of the interurban car is devoted to a smoking

neath it and the other having a pit of sufficient size to be used in taking out a truck. This shop is equipped with a full line of machine tools and other apparatus used in repair work.

#### POWER-STATION BUILDING.

Everything connected with the physical equipment of the system has been very carefully looked after and one of the best evidences of this is the power-house itself, which is a well-planned, well-built fire-proof structure. The exterior walls are faced with standard pressed brick laid in ¾ English bond with headers in each fourth course, affording a thorough bond into the wall. All of the interior surfaces in the engine-room which have not been enameled are faced with Kokomo pressed brick of buff color and the remaining brickwork is of the ordinary kiln-run quality. Tile roofing covers the building.

The foundations above grade are of the best Indiana cut building limestone and below grade of concrete resting on bedrock.

The floors are of concrete with



smooth surface, the engine-room floor being supported on steel beams and under each of the turbine units there is an independent concrete foundation to a depth of 13 ft. 6 in., foundations for the exciters, condensers and other auxiliaries being correspondingly strong. All machinery foundations rest on bedrock.

#### LIGHTING SYSTEM.

As above intimated, the lighting system of the Company has developed at an almost incredible rate. One feeder now goes out from the power-station to the North Kokomo distribu-

tion system and another supplies South Kokomo, each being fed from the 2200-volt two-phase primary circuits; and, in addition, there are four series alternating-current arc circuits of 50 lights each, fed from transformers at 4000 volts.

The towns of Swayzee and Greentown are both furnished with lighting current taken through transformers from the high-tension lines and stepped down to 220 volts.

#### ORGANIZATION AND PROSPECTS.

Mr. G. J. Marott, who lives in Indianapolis, is President of the Com-

pany; Mr. T. C. McReynolds, Secretary, Treasurer and Manager; Mr. P. H. Palmer, Engineer, and Mr. H. P. Martzold, Superintendent of Transportation. To each of these officials must be given credit for far more than the average enterprise and foresight, and to these actively concerned in the operation of the system for downright hard work. With a management so intensely interested in promoting the welfare of a company, success is unavoidable, and the best prophecy of the future is the very encouraging testimony of the present.

## An Exhaust Steam Turbine Plant

An excellent example of the utilization of exhaust steam from prime movers by exhaust steam turbines is that afforded by the Wisconsin Steel Company's mill at South Chicago. This installation, the first of its kind in America, is interesting from both the mechanical and electrical standpoint, and possesses many unique features of design.

Prior to the perfection of the exhaust steam turbine, the greatest drawback to the successful use of the exhaust steam from factories and mines for the production of energy was the unsatisfactory utilization of this exhaust steam effected by reciprocating engines. A reciprocating engine worked with an initial pressure approaching that of the atmosphere would require dimensions so enormous as to make its weight, space occupied and cost in proportion to output, prohibitive. It has been found feasible, however, to build a steam turbine of large capacity, moderate dimensions and high efficiency. The efficiency of turbines in fact is more satisfactory as the steam pressure is lower, because of the reduction of losses due to leakage between the rotating and stationary parts and the friction of the rotating discs and the steam, as these two losses are practically proportional to the specific weight of the steam and accordingly are smaller as the specific volume of the steam is greater. The turbine now in operation at South Chicago is a good example of the efficiency of such an installation.

The turbine, which is of the well-known Rateau type, manufactured by the Western Electric Company, utilizes the exhaust steam from the reversible engine used to operate the blooming mill. The engine driving the blooming mill is a double cylinder, reversible type common to rolling mill operation. This engine runs non-con-

densing and under normal conditions develops a little over 1000 h.p. The steam after passing through the receiver where the shock of the puffs of steam is removed, enters the accumulator or "regenerator," and from there passes to the turbine and condenser.

The receiver tends to relieve the accumulator of the severe shock and strain which would result if the engine were allowed to exhaust directly into it. The receiver is provided with an exhaust valve to be used when there is more steam than necessary to meet the demands of the accumulator and turbine. In such a case the valve is opened to the atmosphere.

The accumulator or "regenerator" is perhaps as interesting as the turbine itself. It consists of a horizontal tank divided into two decks, each deck be-

ing fitted with a series of flues. This allows steam generated in the lower deck to pass up through these flues to the upper deck. This accumulator acts as a sort of a heat reservoir, absorbing or giving up energy as required by the turbine. The steam entering the accumulator at the bottom by means of a series of pipes, the ends of which are perforated, passes through the water in the accumulator. Part of this steam condenses, giving up heat to the water in the accumulator. As the accumulator operates at practically atmospheric pressure, we have, when the engine is running, a large mass of water in the accumulator at 212 degrees Fahrenheit. Now in case the engine stops, the supply of exhaust steam is cut off. If the turbine is loaded, the steam passing through it to the condenser will tend to lower the

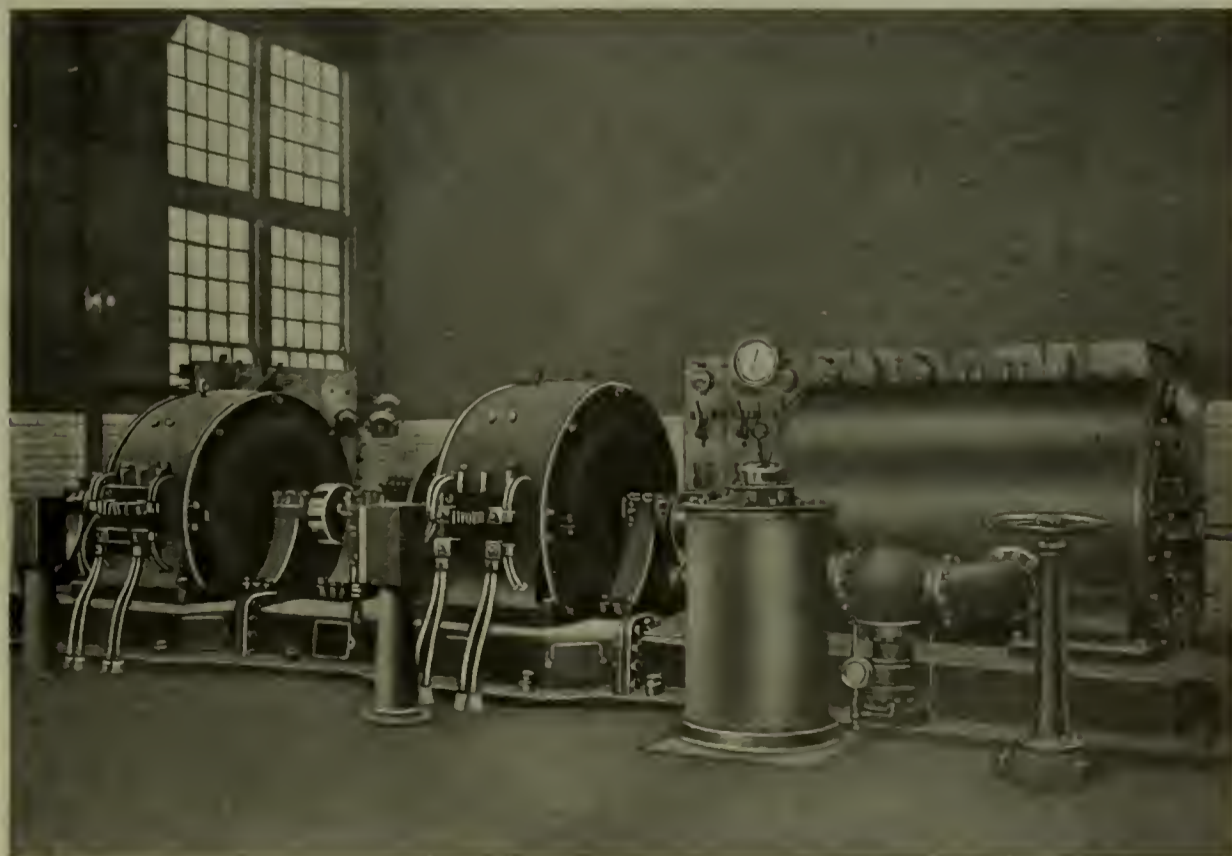

WESTERN ELECTRIC EXHAUST STEAM TURBINE.

pressure of the accumulator. As the water is at 212 degrees Fahrenheit, a temperature slightly above that corresponding to a decrease in pressure, this water will give off steam and act as a boiler operating at atmospheric pressure. This evaporation will cool the water so that when exhaust steam is again admitted to the accumulator, the water will absorb heat. In case the supply of exhaust steam should by any reason be cut off from the accumulator for too long a period, live steam can be admitted by means of a reducing valve. The capacity of the accumulator is such, however, that the turbine will run seven minutes before this valve opens.

The turbine is of the Rateau type shown in Fig. 1. In its design special attention was paid to mechanical strength because of the heavy, continuous duty to which these machines are subjected. Its wheels are turned from solid steel plates and the buckets

are of a non-rusting alloy possessing great mechanical strength. Each bucket is riveted to the rim of the wheel by specially designed rivets. By dividing the turbine into many stages, the steam velocity within the wheel is very low. This prevents the impinging jets of entering steam from wearing the buckets. The speed of the turbine is regulated by a spring-balanced fly-ball governor which operates a throttle valve located in the vertical cylinder seen in Fig. 1. Owing to the low steam pressure this valve is unusually large. This arrangement gives a regulation especially good in spite of the sudden changes of load.

The dynamos, of which there are two, mounted on the same shaft as the turbine, were designed especially for this installation by the Western Electric Company, and possess some interesting features. These machines are each 250 kw. direct current generators, operating at 250 volts. The arma-

tures are of the ordinary iron-clad type but built much stronger. Due to the high peripheral velocity common to turbine driven sets, and the high coefficient of expansion in long commutator bars, the diameter and length of the commutator are limited. To avoid any possible trouble the commutator was divided into two parts connected by means of tangs. The fields are of the usual type standard in direct-current machines, commutating poles being used because of the high speed and large current. The armature is kept cool by means of fan blades attached to the armature and to prevent noise, so common in high-speed machines, the frames are enclosed in end bells. One of the strongest features of these machines is their overload capacity. For several hours at a time one of these has carried the entire load while the other remained idle.

## Cutler-Hammer Push-Button Specialties

Once in a long while an invention is made that is not merely evolutionary, but revolutionary. A switch mechanism with only three parts is such an invention.

It resembles none of the many switches now on the market, and it is much simpler than any of them. It is manufactured by the Cutler-Hammer Manufacturing Company, Milwaukee, Wis. The line includes porcelain pendent switches, porcelain surface switches, together with sub-bases, and porcelain push-button lamp sockets. The accompanying illustrations show the component parts of the mechanism of these switches and also show some of the present applications. The illustrations, however, indicate only in a way the high degree of ingenuity which this device represents.

The switch consists essentially of three parts: a push-bar extending clear through the switch, a coiled steel

The principle embodied in the switch mechanism is that of a coiled spring contracting on a tapering surface, the action being similar to that of a rubber ring slipped over the knob

tact-piece cannot be moved part way and let slip back again drawing an arc.

This new line of Cutler-Hammer push-button specialties is made of porcelain, which is non-corrosive and non-conductive. They will not tar-



CROSS-SECTION OF COMPLETE PUSH-BUTTON SHOWING THE THREE PARTS OF THE SWITCH IN POSITION



ACTUAL SIZE

Brass Cap  
Porcelain  
Pendent Switch  
6 amperes, 125 volts  
2 amperes, 250 volts

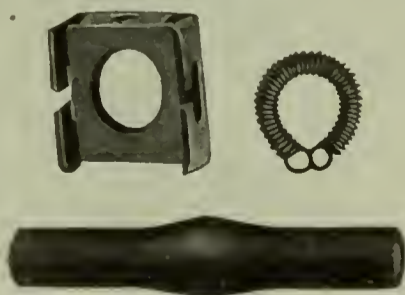

THE SPRING, PUSH-BAR AND CONTACT

spring and a moving contact-piece. These three elements may be assembled in any form of receptacle to perform any switch function which may be required.

of an umbrella or a coiled-wire sleeve supporter which, when passed over the elbow, will travel a short distance up or down the arm of itself. The action is snappy and positive in either direction. The mechanism gives a quick "make" as well as a quick "break," the movement of the contact-piece is the same whether the push-bar is moved fast or slow. The con-

nish and the user cannot receive a shock, because all of the metal parts are encased in porcelain. Any slight arcing which might possibly occur is

confined to a porcelain chamber away from the circuit wires and terminals. Liberal space is provided for knotting

of these devices an easy matter. A removable fibre bushing is furnished with each of the pendent switches and the lamp socket, reducing the size of the outlet to the diameter of standard cord. When reinforced cord is used, this bushing is removed.

The fire glaze on the porcelain is practically indestructible, and the choice of color is such that a shade can be selected that will harmonize with the surrounding trim. The standard glazes are plain white, ivory tint, wood brown and neutral gray. Special glazes can be furnished to order.

These devices are approved by the Underwriters' Laboratories at Chicago.

**John A. Roebling Memorial.**

The Roebling Memorial Association dedicated on June 30th a beautiful statue of John A. Roebling, the famous engineer and founder of the John A. Roebling's Sons Company. This monument to the memory of one of America's greatest engineers was erected by the people of Trenton and the surviving sons of Roebling. The exercises at the unveiling of the statue by Miss Emily M. Roebling, a granddaughter, were attended by 15,000 people and preceded by a memorial parade of over 6000 men.

**Book Reviews.**

**BRENNAN'S HAND BOOK.** A compendium of useful legal information for business men. By B. A. Brennan, contract manager of the Westinghouse Machine Co. 571 pages, 4 by 6½ inches. Published by *The Electric Journal*, 422 Sixth Ave., Pittsburg, Pa. Price \$6.00.

**THE COLORADO SPRINGS LIGHTING CONTROVERSY.** By Henry Floy, Consulting Engineer, New York City. Pages (6 by 9 in.) 327, with Numerous Diagrams and Illustrations. Price, \$4.00. Postage, 25 cents. Illuminating Engineering Publishing Co., New York.

This volume puts in readily accessible and authentic form the main essentials of contracts, not in the abstract phraseology of the lawyer, but in language that the ordinary engineer can readily grasp and appreciate. The definitions and various forms of procedure are, however, rigorously exact. The book contains the statute law of the various States bearing on its subject-matter.

The connotation of the phrase "an arc lamp of standard 2000-c.p." is determined by a board of arbitration appointed to settle a dispute about a municipal lighting charge made by the Pike's Peak Hydro-Electric Co. against the city of Colorado Springs. The book contains a complete record

of the testimony of leading engineers who are recognized as experts in illumination, and as such is valuable to central stations owing to the fact that it goes thoroughly into the subject of arc-light measurement and presents valuable data on the efficiency of open and enclosed arc lamps.

**News Notes.**

The R. D. Nuttall Company, of Pittsburg, announces the establishment of a new department to be devoted exclusively to the manufacture of gears and pinions for air compressors.

The offices and works of The Hada-way Electric Heating & Engineering Company, which was some time since acquired by the Westinghouse Electric & Manufacturing Company, have been removed from 238 West Broadway, New York, to the works of the Electric Company at East Pittsburg.

The Buffalo Copper & Brass Rolling Mill, of Buffalo, N. Y., recently purchased electric equipment for the new plant at Black Rock Station, consisting of a 500-h.p. and two 250-h.p., 2300-volt Allis-Chalmers type "ANY" variable speed induction motors. These units are for use in driving rolling trains in a copper mill where the chief product is the manufacture of copper sheets. B. J. Dashiells, C.E., is consulting engineer in charge of the new construction and equipment.

The Great Western Power Co., of California, has ordered from the General Electric Co. the largest transformers known in the history of the electrical industry. The total weight of each will be 128,000 pounds, of which 40,000 pounds is due to the 5000 gallons of oil used in each machine for cooling and insulating purposes. Each transformer stands 20 ft. above the floor and measures 9 by 18 ft. They will be used to transmit 40,000 h.p. at 100,000 volts 165 miles along the Pacific Coast from the Feather River development.

The net earnings of the Western Electric Company for the year 1907 were \$1,217,000, against which dividends of 8 per cent., or \$1,200,000, were paid, leaving a balance to surplus of \$17,000. Sales for 1907 were \$52,724,168, as compared with \$69,245,332 for the previous year, a decrease of 23.9 per cent.

During the past year the indebtedness of the company has decreased a little more than \$9,000,000, with an increase of cash on hand of over \$1,000,000. The capital stock of the company is \$15,000,000 and its surplus on hand is over \$18,000,000, and it is now in better financial shape than it has been at any time within the last year.



ACTUAL SIZE

Porcelain Pendent Push Button Lamp Socket  
50 candlepower, 250 volts.

the flexible cord and the removal of a single screw gives access to the interior of the switch, making the wiring



ACTUAL SIZE

Porcelain Surface  
Switch (for concealed work)  
6 amperes, 125 volts  
2 amperes, 250 volts

Made also for molding work.  
Can be furnished in either style with label holder (as shown above) or without label holder.

**Trade Notes**

A new 1500-kw. Allis-Chalmers synchronous motor generator set with suitable switchboard and controlling apparatus will soon be installed in the West Temple substation of the Utah Light & Railway Company of Salt Lake City.

The Winona Interurban Railway Company, Winona Lake, Ind., operating 30 miles of interurban railway from Warsaw to Goshen, Ind., will install in its main power house a new 500-kw. Allis-Chalmers steam turbo alternator in addition to two Allis-Chalmers cross compound engines, 20 and 42 in. by 48 in. driving 600-kw. Allis-Chalmers alternators and complete substation and railway apparatus now in service.

The Joseph Dixon Crucible Company, Jersey City, N. J., report that their graphite brushes, which are made in only one quality, are giving excellent satisfaction. They frankly acknowledge in their literature that a one quality brush is not adapted to all conditions, but do say where their brushes are adapted they give an unexcelled service. Their use results in the commutator taking on a highly polished surface, smooth and well-rounded. Since the installation of their own electric plant some eight years ago, they have not had occasion to turn down their commutators, and reasonably attribute the condition of the commutator to the use of their graphite brushes.

The Dixon Co. is mailing a concise booklet of 12 pages on commutation, which includes information concerning the testing of brush pressure, the filing of mica insulation, and some conclusions from tests by Prof. Albert F. Ganz of Stevens Institute.

The rapid advance of the Dossert Solderless Connectors in the trade is shown by the steady increase in orders received for these remarkably efficient labor-saving devices. Among recent orders received by Dossert & Company, 242 West 41st Street, New York, are third rail clamp connectors for 1,000,000 cm. cable from the New York Central & Hudson River R. R. Co., cable taps 400,000 cm. main to 0000 bleeder from the Chicago City Railway Co., and cable taps for 1,000,000 cm. cable from the Syracuse & South Bay Electric Ry. Co.

Among recent crane shipments by the Northern Engineering Works, Detroit, Mich., are mentioned a 7½-ton, three-motor electric crane at the Cummings Foundry, Chicago; a 7½-ton, three-motor electric for the United Lead Co.; a five-ton, 38-foot

span crane for the West India Electric Co., and a six-ton, three-motor electric crane for Valentine Bohl Co., Waterbury.

The Compania de Transvias Luz y Fuerza de Guadalajara, S. A., has purchased a 750-k.v.a. Westinghouse belted three-phase alternator.

A new seamless trolley pole is being put on the market by the R. D. Nuttall Co., Pittsburg, Pa.

The Circuit Court of the Northern District of Ohio has upheld the metal sleeve drum controller patent of the Westinghouse Electric & Mfg. Co. as against the Electric Controller & Supply Co., Cleveland.

The Cutler-Hammer Mfg. Co. of Milwaukee, makers of electric controlling devices, has just completed arrangements whereby this firm will be represented on the Pacific Coast by Otis & Squires, of 111 New Montgomery St., San Francisco. Mr. A. W. Vinson, who for several years has been connected with the engineering department of The Cutler-Hammer Mfg. Co., has been transferred to the office of Otis & Squires, where his services will be available to those confronted with problems of electric control which cannot be met by the use of standard apparatus.

A five-ton, three-motor electric steel derrick of 75 ft. radius and 60 ft. lift, has just been installed at the plant of the St. Louis Basket & Box Co., St. Louis, Mo. The derrick was manufactured and installed by the Northern Engineering Works, Detroit, Mich. It is of the high-speed type, hoisting at a speed of 60 ft. to 125 ft. per minute.

The Electric Goods Mfg. Co., which lately sold its jobbing business to the Western Electric Co., will continue to manufacture the Samson battery and its other well-known specialties.

A handy torch for electricians and linemen is being manufactured by the Frank Mossberg Co., Attleboro, Mass. Lighting is accomplished by merely holding a match under the neck of the torch. Price, \$1.50.

**Catalogue Notes.**

The General Electric Company, Schenectady, N. Y., has just issued a small and attractive circular (No. 3664) descriptive of its new locking socket. This socket prevents the removal of an incandescent lamp by an unauthorized person.

The General Electric Company, Schenectady, N. Y., has issued a new bulletin on Thomson Astatic Instruments for Continuous Current Switchboards.

The General Electric Company, Schenectady, N. Y., has just issued a very comprehensive bulletin (No. 4593) devoted to the subject of "Railway Converter Sub-Stations." The publication gives a general description of the various pieces of substation apparatus and contains also plans and elevations showing different arrangements of substation apparatus.

The Watson-Stillman Co. have just issued a catalogue of 130 pages, describing and illustrating over 100 different hydraulic presses and tools, whose main purpose is the making and breaking of force fits in the assembling or separating of machinery and similar work. Write for Special Forcing Catalogue Bd, A. The Watson-Stillman Co., 26 Cortlandt Street, N. Y. City.

Bulletin No. 31, of the Hyatt Roller Bearing Co., Newark, N. J., shows over 300 sizes for varying speed and load.

The Cutler-Hammer Mfg. Co., of Milwaukee, has just issued a 16-page pamphlet descriptive of their "Wirt Type" dynamo brush, designed for use with low-tension direct-current motors and generators, alternating-current generators, plating dynamos, exciters, etc. The construction of the brush is fully described and illustrated and contains useful information on the care of commutators and brushes, the importance of correct lap, etc.

**Personal.**

Mr. W. J. A. London has recently accepted the position of chief engineer of the Terry Steam Turbine Company, Hartford, Conn., succeeding Mr. C. E. Terry, recently deceased. Mr. London's experience in the turbine industry has been extensive, dating from his early connection with the C. A. Parsons Company, Newcastle, England, and about fifteen years later with Brown-Boveri Company, Baden, Germany, the British and American Westinghouse Companies.

**FOR SALE.**

We offer for sale two complete electric generating plants of 75 and 150 K W rated capacity respectively, and recommend them as bargains. Details upon request.

VENTURA COUNTY POWER CO.  
Oxnard, Cal.

LIBRARY  
OCT 2 1908  
ST. JOSEPH, MO.

# THE ELECTRICAL AGE

Volume XXXIX. Number 8.  
\$1.00 a year; 15 cents a copy

New York, September, 1908

The Electrical Age Co.  
New York and London

ESTABLISHED 1883

Published monthly by The Electrical Age Co., 45 E. 42d Street, New York.

J. H. SMITH, Pres. C. A. HOPE, Sec. and Treas.

JOHN HAYS SMITH, Editor.

Telephone No. 6498 33th. Private branch exchange connecting all departments.

Cable Address—Revolvable, New York.

## SUBSCRIPTION RATES

United States and Mexico, \$1.00; Canada, \$1.50. To Other Countries, \$2.50

## NOTICE TO ADVERTISERS

Insertion of new advertisements or changes of copy cannot be guaranteed for the following issue if received later than the 15th of each month.

## LONDON OFFICES

Business and Editorial Departments, 33 Bedford Street  
Strand, W. C.

London Telephone, Post Office, 3807 Central. Private branch exchange. London Cable  
Address—Revolvable, London.

All remittances to London Office should be crossed London and County Banking Company.

## BRANCH OFFICES AND AGENCIES

Subscriptions may be sent to the following branch offices or agencies, where they will receive the same careful attention as at the home office in New York:

124, Queen St., Melbourne  
359, George St., Sydney  
61, Main St., Yokohama  
23, Esplanada Rd., Bombay

33, Loop St., Cape Town  
Unter den Linden, 5, Berlin  
Nevsky Prospect, St. Petersburg  
31, bis rue de Fauburg Montmartre, Paris

General Agents for United States and Canada: The American News Company

## Announcement

Owing to the serious illness of a beloved member of my family, and her subsequent death, the present issue has been greatly delayed in going to press. Much of the work involved has been done by hands unfamiliar with this sort of thing. If any errors are discovered in the text, I ask our readers to be tolerant in the matter. The October issue will appear more promptly.—THE EDITOR.

## A Campaign of Education

It is evident from the number of reading advertisements now appearing in many of the newspapers and magazines of this country concerning the telephone business, more especially as conducted by the associated Bell companies, that the policy has been adopted, or attempted, by those interests of systematically educating the public on matters relating to the nature and extent of the business, the plans adopted and to be adopted for efficient and prompt service, and the enormous expense that this involves.

Whether these companies will succeed in this attempt to enlighten the public on these matters by a candid presentation of facts and thereby obtain what is presumably the object of the propaganda, namely, at least a reasonably fair treatment at the hands of a public usually somewhat obturate, remains to be seen.

The information contained in these advertisements is also designed incidentally to acquaint the public with the claimed fact that the telephone business, in the nature of things, is a natural monopoly, although those words—usually repulsive to the public mind, however true they may be in this instance—are not employed. This being so, it is then implied that the telephone company which gives the very best possible serv-

ice at rates which allow a fair return on the actual investment of capital, should be allowed undisturbed possession of the field, presumably without interference from would-be competing companies or from adverse or obstructive legislation.

Seemingly, what the officers, as well as the bond and stockholders of public utility industries, do most fear is the fixing of rates and regulations by legislative enactments without due regard to the actual conditions governing the installation and operation of such industries.

Whatever may be the position taken by public service corporations in general on the question of Public Utility Commissions, it is but fair to note that the Bell telephone interests are not likely to be found opposed to the supervision of the telephone business by fair-minded public commissions. If such commissions should, for instance, be appointed in New York State it may indeed be assumed from the action of the Bell interests at the time of the inquiry into the telephone service and rates in New York City by the Merchants' Association of New York in 1905, that these interests will welcome, rather than oppose, their appointment. At that time, it will be remembered, the New York Telephone Company (one of the associated Bell companies) opened its books to the Committee of the Association named, and in every other way possible aided the inquiry. Thus, at preliminary meetings of the committee with the officers of the telephone company, it had been agreed that if investigation showed a net revenue from the telephone service exceeding 10 per cent. (that having been conceded to be a reasonable and proper margin above operating outlays), the rates for service would be lowered to a point

that would bring the net earnings down to a 10 per cent. basis; this being in line with the previous policy of the company, which had voluntarily reduced the rates for service repeatedly within the last fifteen years. The result of the investigation was that a further considerable reduction of the rates to subscribers was made by the telephone company. This was three years ago.

Whether the telephone rates at the present time are fair to the public is a matter open to question. The matter has never received official investigation, and we shall not know until the matter is fairly looked into by a public service commission. We are not in sympathy with those radical papers who want to regulate the business, and we are aware that there are carping critics among the telephone subscribers whose vision is so narrow that they can only see the desk receiver before them, and, having heard that this piece of apparatus can be bought for eight or ten dollars, denounce as exorbitant the charge of \$80 or \$100 per annum for their telephone service. These critics do not realize that this desk instrument is but an infinitesimal part of the telephone system. They do not follow the wires that lead from the instrument to the expensive cables which run through miles of underground pipes or conduits, for which a large annual rental is paid, to all the other subscribers' offices, and to the various Central Exchanges into which each wire is led in the most painstaking way up to the costly and intricate switchboard, every possible precaution being taken to guard against imperfect workmanship or materials, in order that the most efficient service may be rendered to every subscriber. These critics overlook the fact that a staff of trained and well-paid operators, wire

chiefs, inspectors and linemen is kept on duty, day and night, that the demand of every subscriber at any instant may be promptly met.

They dispute the demonstrable and demonstrated fact that the cost per subscriber of maintenance of a telephone service increases as the number of subscribers increases, for the obvious reason that every new subscriber not only adds his own outgoing calls to the grand total, but his presence on the system adds to the total calls of the existing subscribers who do business with him, thus adding to the work of the staff and to the demands upon the wires until both have to be increased. The fact that rates have been reduced frequently in the face of the great increase of subscribers to the telephone service in many of the large cities of this country is, it may be said, due entirely to the revolutionary economical changes that have been made in the methods of operation of the telephone industry.

#### Transformer Iron

Within a year the two or three leading makers of transformers have put out for commercial use a transformer having a steel in the laminate core different from that formerly used. By the use of the improved steel core, losses have been reduced one-half.

Steel for magnetic purposes has always been a source of trouble to manufacturers. The larger companies have steel manufactured according to their own specifications, and even maintain inspectors at the steel mills to see that what is specified is delivered.

Iron ore worked up into steel carries with it a great many elements other than pure metal. These elements are usually termed impurities, because of the small quantities in which they appear, generally in fractions of one per cent. Carbon appears in the largest quantity, usually ranging up to even two-tenths of one per cent. Phosphorus, silicon, sulphur and manganese are also found in large quantities. As it was early discovered that slight variations of these elements made wide differences in the final product, all the early magnetic steels were made as nearly pure steel as it was possible to obtain.

An undesirable factor in these early metals was a physical change termed aging, due to reheating when in service. This was one factor which remained nearly constant, no matter what the chemical composition of the steel, and was considered an inherent feature of the metal. As years went by improved methods of annealing

made aging less severe than at first, but yet a serious problem.

It is now found that aging is due to the composition of the metal. After much experimenting, iron ore with an addition of about 35 times more silicon than came with it has been found to give desired results. This metal reduces the hysteresis losses, and by reason of its higher specific resistance cuts down eddy current losses too. Aging has been reduced to a point where it is almost negligible. How important this point is may be understood from the fact that ten years ago losses of 10 per cent. after a few months' service were common in transformer cores.

A number of new mixtures are now used, but with an increase in silicon of a small change. The addition of a small quantity of vanadium has been claimed to give good results. All these changes have improved every feature of the transformer, because losses, regulating and magnetizing current are all more or less interrelated.

#### Empire State Gas and Electric Association. October 7

The annual meeting of this Association will be held in the United Engineering Societies Building, 29 West 39th Street, on October 7, 1908. Among the subjects to be discussed are: Public Policy Work of the Association; Standards for Gas Service and Standards for Electric Service, taking as a basis the recent rules of the Railroad Commission of Wisconsin; Taxation of Gas and Electric Companies in New York State with a report from the Taxation Committee; Insurance of Gas and Electric Stations; Review of the Decisions of the Public Service Commissions; Electric Meter Testing with Report of the Meter Committee; Accounting with Report of the Accounting Committee; Amendments to the Constitution and By-Laws with a New Schedule of Annual Dues; Affiliation with the American Gas Institute and the National Electric Light Association.

#### The Relation of Rates to Efficiency of Light-Sources

There are some questions which will never be settled; for example, the question of taxes has been a fruitful source of discussion and discontent from the beginning of civilization, and will continue so until the end. Prices of the absolute necessities of life, which, like death and taxes, must be met by everyone, are likewise perennial subjects for discussion. In the first wild enthusiasm over the actual

advent of the incandescent electric lamp the report was circulated through the press that this wonderful new light would be only one-fourth as expensive as gas. As gas was then only used in the old-fashioned flame burner, the extravagance of this claim seems almost beyond the limits of even our fantastic American journalism.

But since that time there has been a steady and uniform reduction in the rates for both electricity and gas. When the microscope of public ownership and regulation of public utilities began to show the effects of its inoculation into the public mind, the lighting companies were the first victims. There was a general pronouncement that we were paying entirely too much for light. Convincing proof to the contrary being either entirely wanting or difficult to produce in a suitable form for public consumption, the simple remedy of reducing rates by legal enactment was largely resorted to. In many cases very material reductions in rates were made to forestall legal enactment. Now, by a curious coincidence, it happened that after thirty years of practical running on a deal level so far as efficiency was concerned, a prodigious improvement in the efficiency of the electric light began simultaneously with public agitation for lower rates.

Generally speaking, it may be said that the new electric lamps, both arc and incandescent, produce light with one-third of the current expenditure of the types which they are superseding. But no such reduction in the cost of light was contemplated, or even dreamt of, by those who were instrumental in reducing lighting rates by legal enactment. The people are now congratulating themselves on the prospects of this double reduction in cost of light, resulting from the reduced cost of electric current, and the greatly increased efficiency of light-sources. The increase in light efficiency is the outcome of scientific research and discovery, and the results are appropriated by the people with a clear conscience as to their rights to the entire benefits.

But there is another side to this story; there is principle of equity involved. If no more light were used, and its production were effected by one-third of the current by the improvements in lamps, one of two things must result—either the company supplying the current would have their revenues reduced considerably below the profit line, or there would be conclusive proof that their previous profits had been exorbitant.

An attempt to raise the rates, either horizontally and openly, or covertly by ingenious schemes of framing contracts, will doubtless call forth a wail

of protest on the part of consumers. But this fact must never be lost sight of: the supplying of electric current must produce a profit, as in the case of all other enterprises; and if progress in the art so changes conditions that only one-third or one-tenth of the current will be demanded, it is a perfectly logical conclusion that the price of the current will have to be raised.

Undoubtedly the users of light should be beneficiaries of all improvement in the art; but it is equally certain and equitable that those whose time and money is invested in the production of electric current should likewise share in the improvements. The cheapening of light will undoubtedly increase its use, but it is quite conceivable that such reductions in the cost of producing light might be discovered as to far more than offset this increase in use. Under these conditions there is but one solution of the problem: an increase in the price of current.

The possibility of such a contingency should be at once realized by both the lighting companies and the people. What the people want for their money is illumination; the electric current is only an intermediary of which they know little, and care less. The way out of the difficulty is for the lighting companies to educate their customers up to the idea of buying *light* instead of electric current. If consumers' lighting bills were reduced one-third, they would undoubtedly consider themselves very fairly dealt with; and yet this would represent only a half of the saving in current, and would therefore be equivalent to an actually higher rate for the current consumed.

It is a curious fact, which has been frequently alluded to of late, that light, which is one of the absolute necessities of civilized life, and one of the most valuable of commodities, has never been bought or sold as such, its money

value always having been computed on a basis of the amount of luminant consumed. This anomalous custom must be superseded, and the logical and scientific basis of charging for light upon the amount of light furnished adopted in its place. The general public know nothing about kilowatts or kilowatt hours, and it will be easier to educate them to an understanding of candle-power and foot-candles—measurements which depend upon plain vision—than to attempt any legerdemain with electrical terms. Competition and the general expansion of business may be counted on with perfect safety to maintain rates at a reasonable figure in the long run. Lighting companies should be the first to benefit from improvements in their art, but to make sure of securing this condition they must at once undertake the business of selling light, rather than electric current.

---

#### Artificial Lighting of Public Schools

Examinations have shown that there are from 8000 to 10,000 children in the New York public schools afflicted with defective vision. This condition has rightfully aroused a degree of interest on the part of the school board, the health authorities and the general public. A self-constituted committee, after considering the subject, advised that all text-books be printed on unglazed paper, and that line-cuts or wood engravings be used for illustrations in place of half-tones. The recommendation is unquestionably based on sound principles; but the most important matter of all has thus far been entirely neglected or overlooked, and that is the lighting of the school-rooms by artificial light. In the new buildings the daylight is generally

well provided for, but there are many of the older buildings in which conditions are such that in the short, dark days artificial light must be used to a considerable extent. In these cases the crudest and most injurious methods of lighting are generally practised.

Illuminating engineering has been vigorously taken up by many of the central stations—those detested public utility corporations which have been such a target for political demagogues—while boards of education, who have autocratic control of public education and the welfare of the millions of children throughout the country, have, with few exceptions, taken no notice of this most important item in the equipment of school-rooms. In this respect, we might learn a useful lesson from Germany, which several years ago had the whole matter of lighting school-houses investigated by a special commission appointed by the government.

Here the children are compelled to study books on physiology and hygiene, which have been specially written to impress upon them the necessity and methods of properly caring for their health; and while these books contain much sage advice and many statements which have no foundation in scientific fact on the use and abuse of stimulants, they contain not one word of direction as to the use of artificial light in connection with the protection of the organs of vision. Consistency is proverbially a rare jewel, and in the case of the administration of many of our public offices, it is practically an unknown quantity. The sooner the question of lighting is taken up and referred to a competent commission or committee of experts, including oculists and illuminating engineers, the better it will be for the welfare of school children, whose number in New York City alone is five times that of our entire standing army.

# High-Tension Switchboard Practice in America

By STEPHEN Q. HAYES

THE operating voltage of transmission plants has been steadily increasing of late years, and the switching equipment necessary for the control of the high-tension circuits has kept pace with the improvement in design of transformers, insulators, etc., which make high-voltage work possible. With practically no exceptions, all plants in America designed for high-voltage work employ three-phase circuits, and obtain the high voltage by means of transformers, and this is the type of plant considered in this paper.

In designing the switchboard equipment for any plant, there are two main features to be considered—the general connections desired and the means necessary to obtain them.

When considering the main connections desired in any plant, it is necessary to carefully weigh the relative values of flexibility and simplicity, and to balance up the cost of apparatus needed only in an emergency against the loss that might occur if provision were not made for such a contingency. The general problem resolves itself into obtaining the maximum amount of flexibility and insurance against shut-down, with the minimum outlay for apparatus and building. As the cost of the apparatus and the space it occupies increases rapidly with increase in voltage, many ingenious and effective schemes have been adopted for reducing to a minimum the number of high-tension breakers, switches, etc.

The relative advantages of the single bus-bar system, double bus-bar system, group system, ring system and their combinations and modifications have to be carefully considered, and the system finally decided on is usually a compromise between flexibility and cost. Wherever possible, it is usually advisable to have the transformer banks equal in capacity to one, two or three generators, and to make the capacity of the line equal to one or two transformer banks. This permits independent operation with the minimum amount of apparatus and the maximum amount of flexibility.

In practically all modern plants the high-tension circuits are controlled by electrically-operated oil switches, or oil circuit-breakers, and the electrical

operation is often extended to the field rheostats, field switches, governor motors, etc. The controllers or switches for operating this apparatus, together with the meters for indicating and recording the current voltage, etc., of the various circuits, are mounted on a switchboard of the panel type, on pedestals or control desks depending on individual tastes and local conditions.

For switchboard panels, pedestals, desks, etc., the material employed is ordinarily blue Vermont marble, or slate, with either oil or marine finish, although white Italian marble, pink

struments, etc., stand out clearly against the dark background.

## PANEL BOARDS.

Where these are used it is customary to mount the equipment of instruments for the generators, transformers, feeders, etc., on the same panel as the controlling devices. This type of construction is employed where the number of units is comparatively small, or where the space needed for instruments is so great that any attempt to reduce the length of the operating board will result in placing the instruments at such a distance from the operator that it will be diffi-

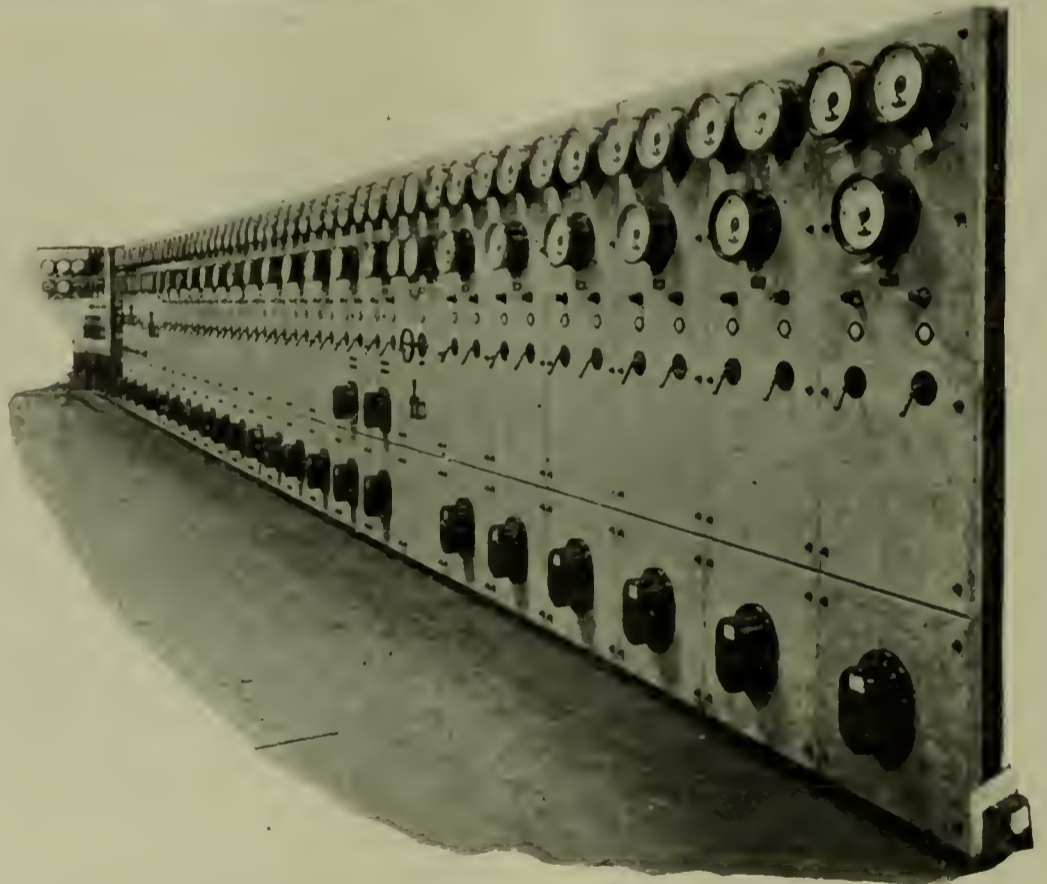

FIG. 1.—PANEL SWITCHBOARD WITH ROUND PATTERN METERS FOR LOUISIANA PURCHASE EXPOSITION.

Tennessee marble, or black enameled marble or slate are sometimes employed.

Owing to the difficulty of matching polished blue Vermont marble and removing oil stains, scratches, etc., the marine or oil-finished slate is rapidly growing in popularity, as the question of matching is then a simple one, and a little paint or vaseline will take care of any oil spots, scratches or other imperfections. This dull, black finish has the further advantage of not reflecting light in the eyes of the attendant, and the controlling devices, in-

cult for him to see the scales and pick out the meters belonging to any one circuit.

Fig. 1 shows the large panel board of blue Vermont marble, with round pattern instruments, supplied in 1904 to the Louisiana Purchase Exposition in St. Louis, and was used to control three 125-volt exciters; four 2000-kw., 6600-volt, three-phase, 25-cycle generators; two 4000-kw. incoming feeders and 17 outgoing feeders. These panels were provided with the usual equipment of instruments, and the breakers were electrically operated.



Fig. 2 shows the panel board of oil-finished slate, with horizontal edgewise instruments, supplied to the Canadian-Niagara Power Company, at Niagara Falls, Ontario, and used for the control of five 7500-kw., three-phase, 25-cycle generators and 20 feeders. This board comprises five generator panels, 20 feeder panels, 10 recording wattmeter panels and three bus-bar interconnecting panels. Each panel is distinct and contains no instruments or switches, except those belonging to the particular feeder or generator in question. Each panel contains all of the instruments and switches involved in any operation which the attendant has to make.

Fig. 3 shows the preliminary drawing of a panel switchboard of marine-finished slate, with vertical edgewise instruments originally proposed for the Rio Janeiro T. L. & P. Co., for the control of four 10,000-kw., 80,000-volt, three-phase incoming lines, six banks of step-down transformers, various 20,000- and 6300-volt feeders, motor generator sets, gas engine driven generators, excitors, etc. The actual switchboard equipment now being built for this plant differs from the preliminary drawing in quite a few respects.

These three examples of typical panel boards show clearly the amount of space required for such an arrangement, and indicate the reason why the general trend of design is towards a more compact grouping of the equipment.

PEDESTAL TYPE.

This type of control is ordinarily used in plants that distribute at the generator voltage and where the number of generators is small in comparison with the number of feeders. Fig. 4 shows the arrangement of the switchboard gallery for the Union Electric Light and Power Company



FIG. 2.—PANEL SWITCHBOARD HORIZONTAL EDGewise METERS FOR CANADIAN NIAGARA POWER CO., VIEW OF NO. 1 SWITCHBOARD.

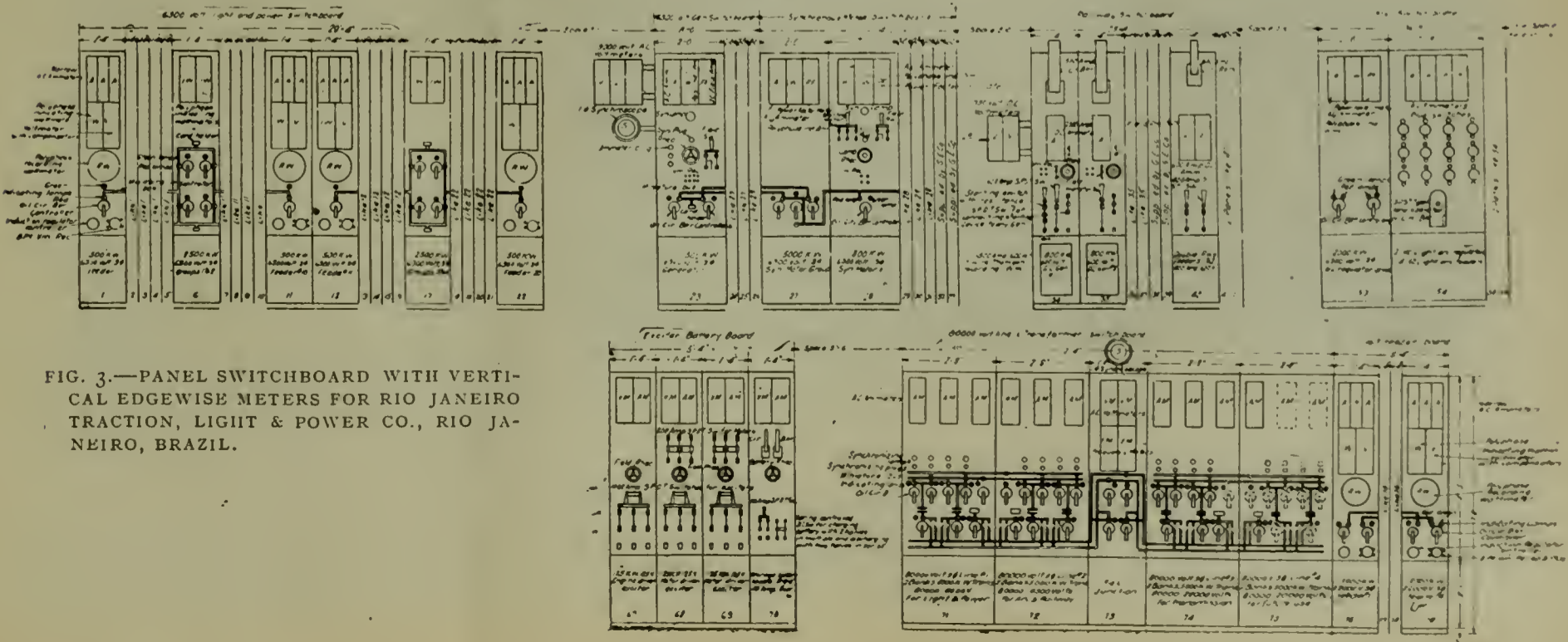

FIG. 3.—PANEL SWITCHBOARD WITH VERTICAL EDGewise METERS FOR RIO JANEIRO TRACTION, LIGHT & POWER CO., RIO JANEIRO, BRAZIL.

of St. Louis, for the control of 11 large number of feeders. The generator controlling devices are located on a pedestal, while the generator in-

struments are placed on posts that act as supports for the gallery railing. A pivoted station post containing voltmeters, synchroscope, etc., is so located that the instruments can be observed from any portion of the gallery. With the arrangement shown the operator in the switchboard gallery at the end of the station faces the generator room when standing at the control pedestals and watching the generator instruments. The feeders are controlled from a panel board back of the operator, while the masonry structure for the bus bars and connections is back of the feeder board.

Fig. 5 shows the control room in the distributing station of the Ontario Power Company at Niagara Falls, Ontario. Each of the six control pedestals and posts is used for the control of one 7500-kw. or 9000-kw., 12,000-volt, 25-cycle, three-phase generator, and one bank of three 3000-kw. transformers, stepping up to 60,000 volts. On these pedestals, in addition to the controllers and indicating lamps, a miniature bus-bar system has been installed to show just what connections have been made by the various breakers. The instrument posts contain the various meters for the generator and transformer circuits, and are provided with testing jacks that permit the calibration of the instruments in position. The 60,000-volt feeder circuits running to Rochester, Syracuse and other points are controlled from the feeder panels shown in the center.

Fig. 6 shows the two galleries below the control room, illustrated in Fig. 5.



FIG. 5.—CONTROL ROOM WITH PEDESTALS AND POSTS, ONTARIO POWER CO., NIAGARA FALLS, CANADA.

The panels on the upper gallery contain complete sets of graphic recording instruments, integrating wattmeters, etc., while on the lower floor the panels contain the relays, fuse



FIG. 4.—GALLEY WITH PEDESTAL POSTS FOR UNION ELECTRIC LIGHT & POWER CO., ST. LOUIS.

terminals, etc., in the various control and meter circuits.

#### CONTROL DESK.

Where it is desired to reduce the length of the operating board to a minimum, it is customary to install a control desk and to mount on it the various controllers for the circuit-breakers, field switches, field rheostats, etc. It is customary to mount the in-

With the control desk the instruments can be mounted either on independent switchboard panels, or on panels forming the back of the control desk, on an instrument frame back of and usually higher than the top of the control desk, or on instrument posts.

Where panels are used with a control desk, ordinarily the panels occupy a greater amount of space than the desk, and it is possible for the station operator to become confused in determining the instruments belonging with a certain generator or feeder whose controlling devices are on the desk. As a rule, card-holders or name-plates are placed both on the desk and the panels, and the grouping of the instruments is made, as far as possible, to correspond with the grouping of the controlling devices.

Where the instrument panels form the back of the control desk, the instruments are, as a rule, arranged to correspond in location with the controlling devices for the same circuits.

A modification of this scheme is to use an independent instrument frame and to arrange this frame at such a height that the station operator, standing at the control desk, can look over the top of the desk and under the bottom of the instrument frame out into the station, and readily observe the operation of the machine he expects to control.

Fig. 7 shows a control desk of oil-finished slate, with horizontal edge-wise instruments installed in the Port Morris Generating Station of the New

struments for the various circuits in such a position, relative to the sections of the desk, as to indicate clearly to the station operator the instruments belonging to any particular circuit.

York Central & H. R. R. R., for the control of six 5000-kw., 11,000-volt, three-phase generators, with various feeders. With this type of desk the station operator has his back towards the generator room—which is usually an objection to this arrangement.

Fig. 8 shows a control desk, with marine-finished slate top and steel plates for the front and sides. The round pattern meters are mounted on separate panels located back of and above the desk at such a height that the operator can look over the desk and under the instrument frame to observe the operation of the generators. This desk controls six generators, two banks of transformers, two high-tension feeders and two local circuits. Hand-operated field rheostats and field switches are used for the generators, which are of comparatively small capacity, and the total length of the board is only 11 feet.

Fig. 9 shows a control desk with vertical edgewise instruments, supplied to the United Railways & Electric Company, of Baltimore. This



FIG. 6.—SWITCHBOARD GALLERIES SHOWING TERMINAL, RELAY AND RECORDING INSTRUMENT BOARDS, ONTARIO POWER CO., NIAGARA FALLS, CANADA.



FIG. 7.—CONTROL DESK WITH HORIZONTAL EDGEWISE METERS, NEW YORK CENTRAL AND HUDSON RIVER RAILROAD, PORT MORRIS POWER STATION, NEW YORK.

desk was arranged to form an arc of a circle, and will ultimately be about twice as large as the portion shown.

A complete miniature bus-bar system is installed on the top of the desk to show the connections made by the

various breakers that are arranged on the group and ring system. Calibrating jacks are installed on the front panels of the desk to permit any of the switchboard instruments to be calibrated in position. The meters are mounted on steel plate and the relays are located on the rear of the desk.

Fig. 10 shows a control desk with vertical edgewise instruments, arranged in the face of the desk in such a manner that the operator can readily look over the top of the desk to watch the generating station which he will face when standing at the desk. The operating portion of the desk is provided with a miniature bus system that clearly shows the connections of the 16 3000-kw. generators, the five 9000-kw. step-up transformers, and the five 66,000-volt transmission lines. Calibrating jacks are provided for testing the various meters in position.

The various switchboard panels, pedestals, desks, etc., previously described, are used chiefly as a convenient location for mounting the controlling devices for the field rheostats, field switches, oil circuit-breakers, etc., and the satisfactory operation of the plant depends more on this latter apparatus than on the panels, pedestals and desks.

The electrically-operated field switches and field rheostats are sometimes combined in a switchboard similar to that shown in Fig. 11, which controls the field circuits of six 5000-k.v.a. generators, and the field and armature circuits of three large exciters in the plant of the Rio Janeiro T. L. & P. Co.

Where the capacity of the rheostat face plate does not exceed 200 am-

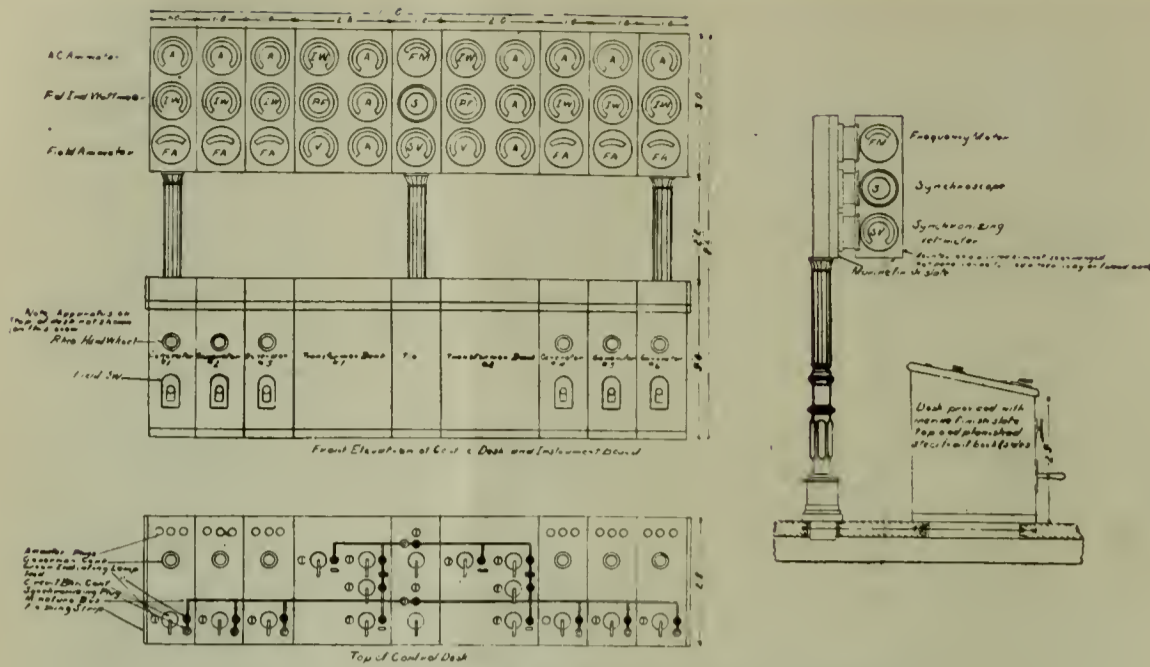

FIG. 8.—CONTROL DESK WITH ROUND PATTERN METERS.

direction is impossible, but rotation in the reverse direction can be accomplished by changing the position of the control switch on the board.

The terms "oil switch" and "oil circuit-breaker," as used by various manufacturers, are practically synonymous, although a distinction is sometimes drawn that an oil switch has contacts of the knife, or plunger type, that tend to remain closed while oil circuit-breakers have contacts of the cone, wedge or brush type that tend to come open, and must be held in by a latch, toggle or similar mechanism.

As it is impossible to describe and illustrate all of the types of oil switches and circuit-breakers now on the market, a few representative ones will suffice as showing the general tendency of design. Most manufacturers have two different types of oil

peres, it is often feasible to install a solenoid-operated rheostat, similar to that shown on Fig. 12, in place of the motor-operated rheostats shown in Fig. 11. This device shown in Fig. 12 consists of a double solenoid and plunger, actuating a knurled-rim wheel by means of a simple lever and pawl mechanism. The knurled wheel carries the switch arm, which cuts in and out the resistance in the usual way. One solenoid operates to cut in resistance by a continuous step-by-step rotation of the switch arm, while the solenoid is energized. The other solenoid cuts out the resistance in the same manner.

Both types of electrically-operated

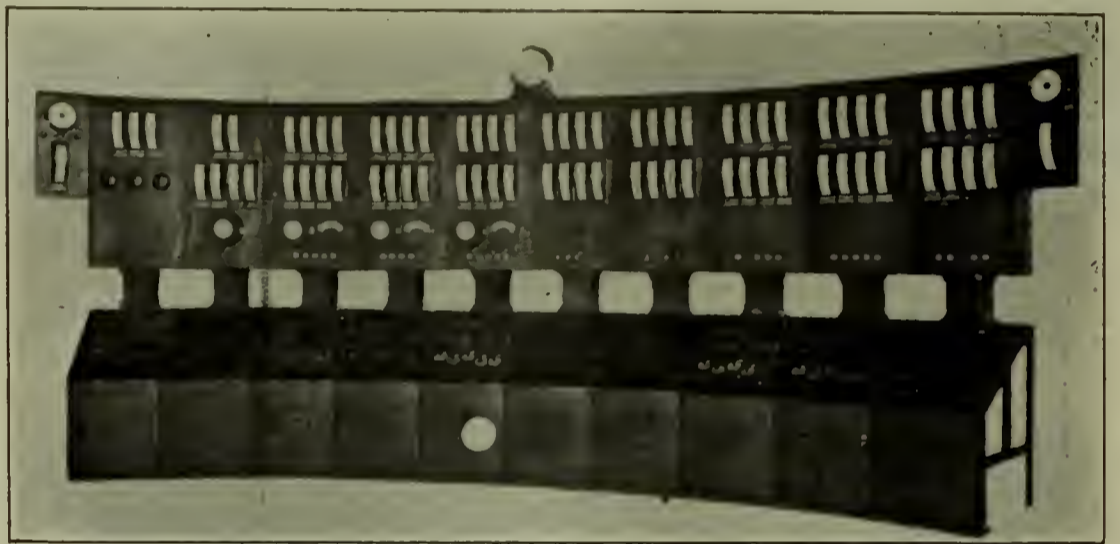

FIG. 9.—CONTROL DESK, UNITED RAILWAYS & ELECTRIC CO., BALTIMORE, MD.

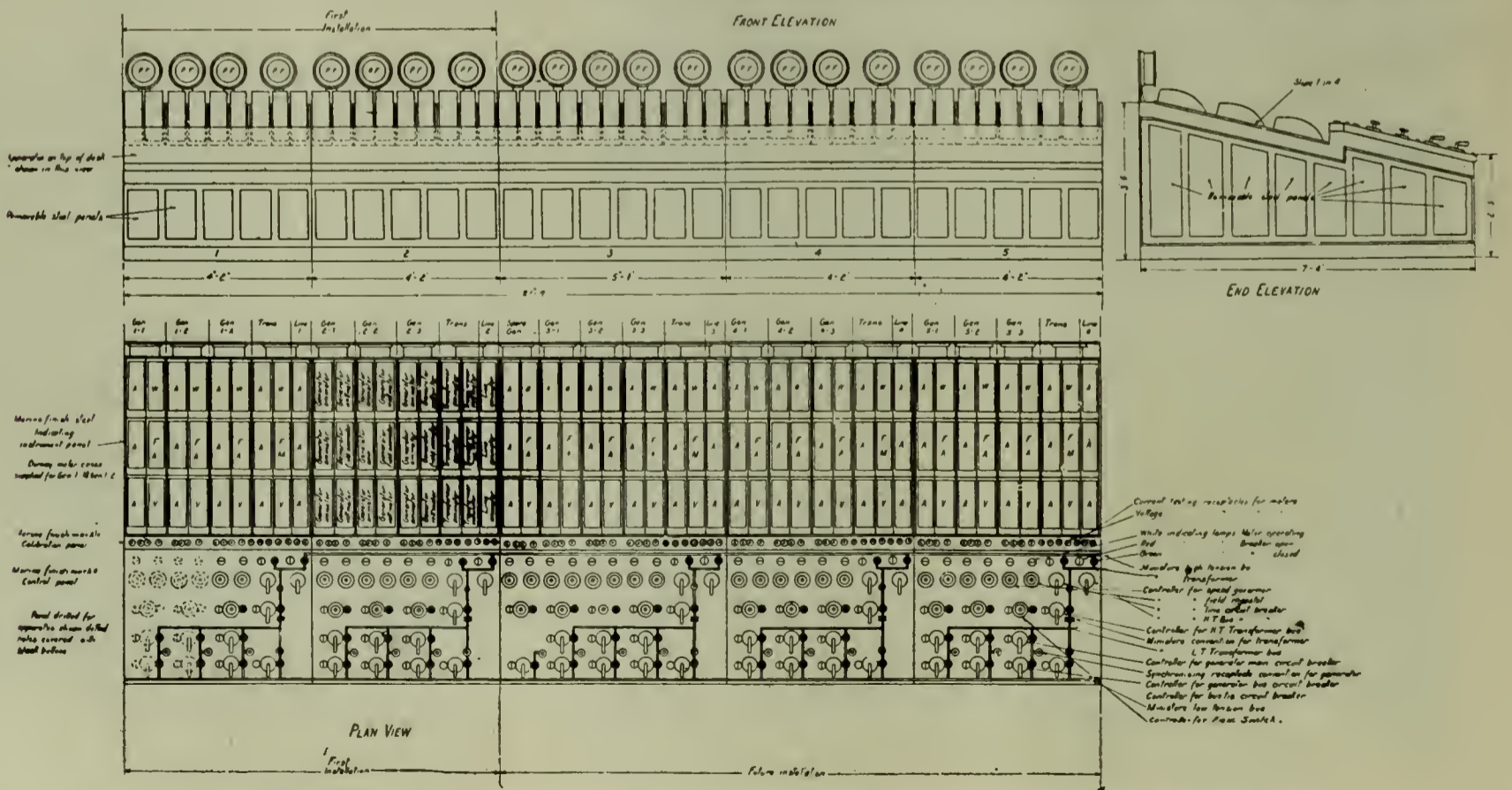

FIG. 10.—CONTROL DESK AND INSTRUMENT FRAME, POINT DUBOIS HYDRO ELECTRIC DEVELOPMENT, WINNIPEG, MAN.

rheostats are provided with limit switches so that when the rheostat arm reaches the limit of its travel in

either direction, the limit switches opens up the operating circuit in such a manner that further rotation in that

switches or breakers—one employed on circuits of less than 33,000, and the other on circuits of more than 33,000.



FIG. 11.—FIELD SWITCHBOARD, RIO JANEIRO TRACTION, LIGHT & POWER CO., RIO JANEIRO, BRAZIL.

For the circuits below 33,000, most manufacturers have two or more types, the larger of which can be counted on to open the circuit satisfactorily with an almost unlimited amount of power available on the bus bars, while the smaller ones have ultimate breaking capacities ranging from



FIG. 13.—SMALL SOLENOID-OPERATED OIL CIRCUIT-BREAKER.

about 10,000 kw. down, depending on the design. These smaller breakers are almost invariably solenoid-operated top connected with metal tanks and insulated linings, and are made either with each set of contacts in independent tanks, or—for the smaller sizes and lower voltages—with all of the contacts in the same tank.

Fig. 13 shows one of these moderate capacity solenoid-operated top-connected breakers that is built in capacities up to 1200 amperes at 3500 volts, and 100 amperes at 33,000 volts, and having an ultimate breaking capacity of 6000 kw. for a two-pole breaker, 10,400 kw. for a three-pole and 12,000 kw. for a four-pole. Each pole of the breaker is intended for mounting in a masonry compartment, and the mechanism of the individual poles is mounted on a treated soapstone base, and a simple system of toggles operated by a powerful solenoid is used for closing the breaker. A second solenoid is used to upset the toggle and trip the breaker. A small single-pole double-throw switch is mounted on the frame of the breaker, and is operated mechanically by the motion of the levers in opening or closing the breaker. This switch controls the signals on the switchboard.

The breakers for use on circuits of less than 33,000 volts, with practically unlimited breaking capacity, are made usually in either of two forms, one of which is essentially a bottom-connected motor-operated device, while the other is top-connected solenoid-operated.

Fig. 14 shows one of the oil switches, supplied in the generating stations and substations of the N. Y. C. & H. R. R. R. With this type of oil switch the leads are brought to the bottom of the two metal tanks in each compartment, and the circuit is completed through the plunger rods that pass through insulated bushings in the top of the tanks. These rods are connected together by metal crosspieces,

and where the amount of current exceeds that which the plunger rods can carry, laminated copper brushes are used for bridging across between the pots. The brushes and plungers are lifted by means of wooden rods, operated by a motor-driven mechanism located at the top of the breaker. Each pole of the breaker is installed in separate masonry compartments, and fire-proof doors are used for closing in the compartments. This style of breaker is very compact and is particularly well suited for connecting to bus bars, located directly below the breaker on a lower gallery. The disadvantages of the breaker are the two live metal pots in the same compartment, the absence of gauge glasses to determine the height and condition of the oil in the pots, the difficulty of connecting to bus bars in a gallery above the breaker, and the fact that a broken wooden plunger rod will result in the breaker falling closed rather than open.

Fig. 15 shows a solenoid-operated top-connected breaker that is built in capacities up to 3000 amperes, and in voltages up to 33,000, and having no limit placed for its "ultimate breaking capacity." Each pole of the breaker is enclosed in a separate fireproof masonry structure, and a single powerful mechanism mounted on a cast iron base and resting on a treated soapstone slab is used with a two-, three- or four-pole breaker. The cone contacts and the general design of this

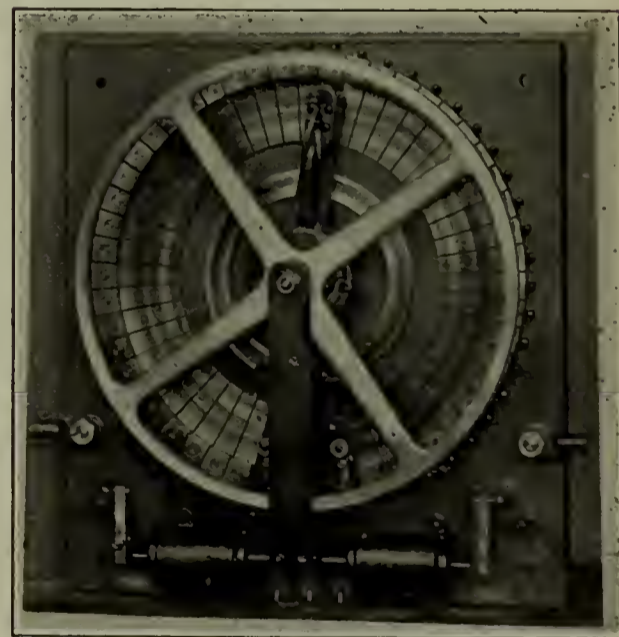

FIG. 12.—200 AMPERE, 46 DIVISION RATCHET FIELD SWITCH. THE TWO SOLENOIDS OPERATE A DOUBLE-ACTING PAWL ENGAGING TEETH MILLED ON SURFACE OF WHEEL.

breaker are such that the tendency is to open rather than to stick, and as the open position is maintained by gravity failure of the mechanism, breakage of the operating rods, or other unforeseen contingencies will cause the breaker to fall open rather than closed. The two terminals of each

phase are in a single metal tank with insulated lining, and each tank is provided with a gauge glass for observ-

chance of an attendant closing these disconnecting switches, while a second attendant is working on the breaker,

out through the back wall and septums being provided to separate the leads, this type of breaker ordinarily requires more floor space than is needed for that shown on Fig. 14, if the bus bars are located below the breakers. With the bus bars back of the breaker, approximately, the same space required for the two types, while with the bus bars above the breakers, the top-connected breaker has the advantage.

Top-connected breakers have their contacts and terminals near the top of the oil, and are not so apt to be troubled with sediment and dirt settling on these contacts as if they were placed at the bottom.

Fig. 16 shows the standard method of arranging the bottom-connected motor-operated breakers for 13,200-volt service with the bus bars below, back of or apart from the breakers. Fig. 17 shows a section through the switching galleries of the Williamsburg generating station of the Brooklyn Heights Railroad, showing the bus bars in an intermediate gallery with top-connected, solenoid-operated breakers above and below them. This also shows the arrangement of the series and shunt transformers, disconnecting switches, etc., in a building where ample space was available for locating the switching apparatus to advantage.

As shown in Fig. 16 and 17, standard practice for all large stations has settled on the enclosing of all the main wiring and bus bars for voltages under 13,200, owing to the enormous momentary amount of current available under short-circuit conditions, with the disastrous arcs resulting at

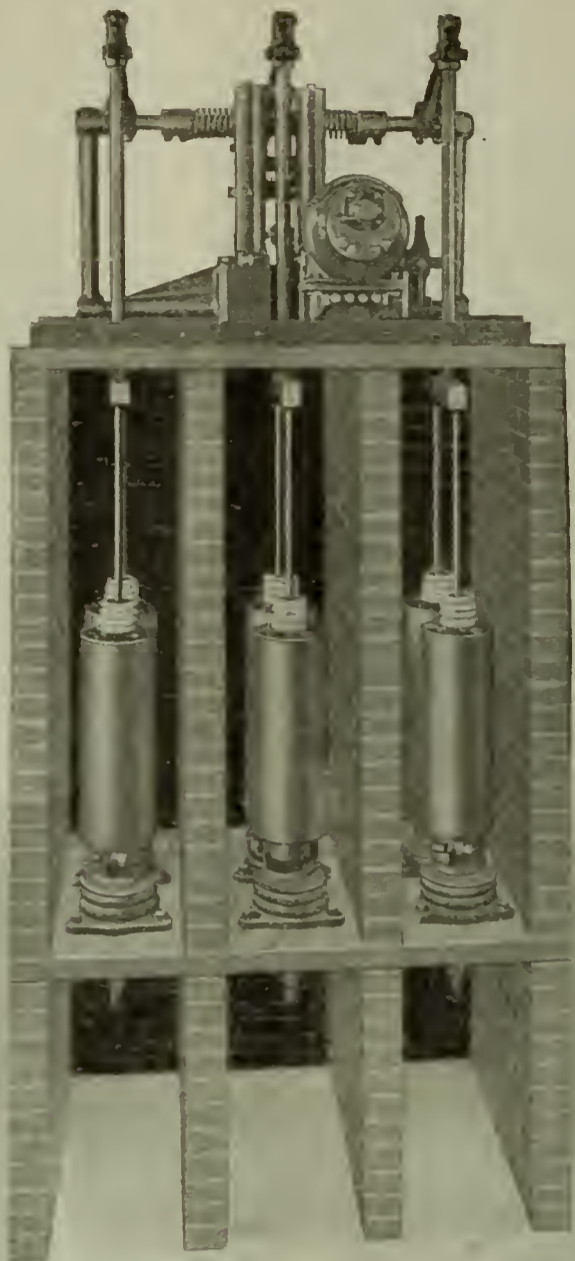

FIG. 14.—LARGE MOTOR-OPERATED 11-3 OIL SWITCH, GENERAL ELECTRIC CO., SCHENECTADY, N. Y.

ing the height and condition of the oil. The doors of the compartments are sometimes provided with clear wire glass panes to permit ready inspection. The leads of this breaker leave the top of the tank and pass out through porcelain bushings set in soapstone blocks in the back wall of the structure. These leads usually come out in separate compartments that keep them isolated from each other, and the leads to the bus bars, feeders, generators, etc., may all run upward or all downward, or some up and some down. This flexibility is often of great advantage, and permits the generator breakers being placed on one floor with the bus bars above them and below the feeder-breakers, thus minimizing the space occupied and the amount of material necessary.

Another advantage of this type of construction is that it permits mounting the disconnecting switches for isolating the oil circuit-breakers on the back wall of the breaker structure, and when so located there is far less

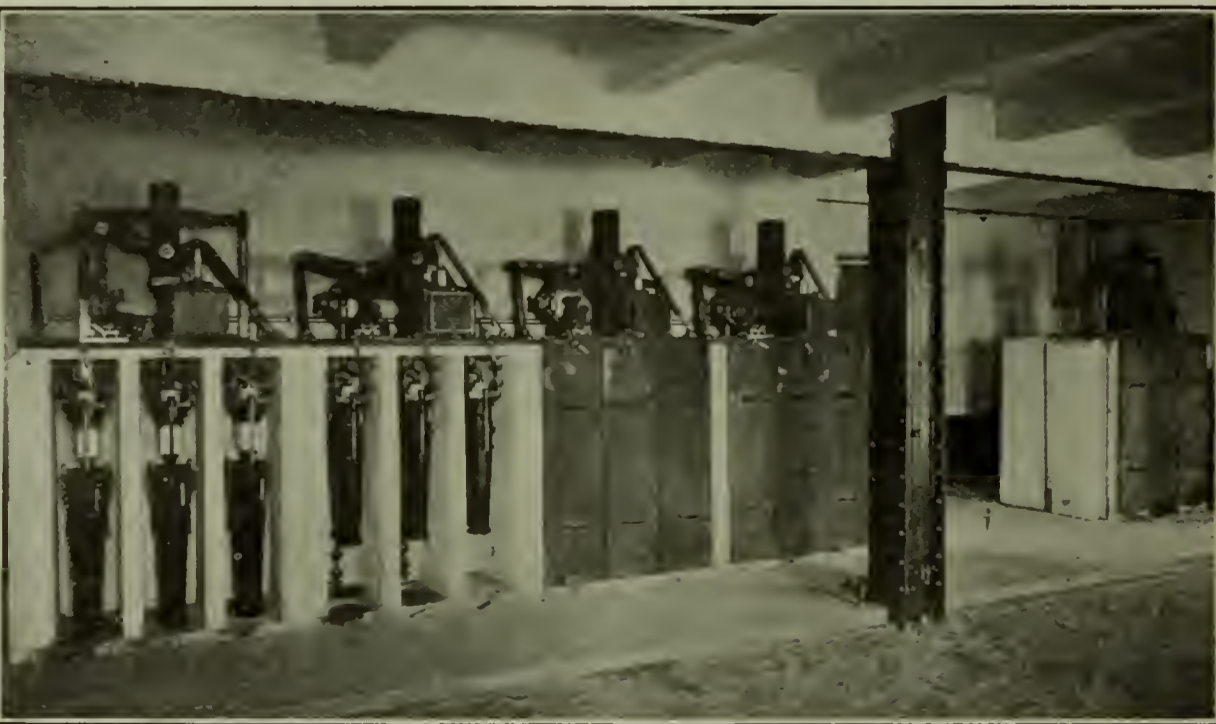

FIG. 15.—LARGE SOLENOID-OPERATED OIL CIRCUIT-BREAKER FOR 12,300 VOLTS, WESTINGHOUSE ELEC. & MFG., CO., PITTSBURG, PA.

than if the switches were on one floor and the breaker on the other.

Owing to the leads being brought

the point of short circuit, but for higher voltages the practice differs. Some engineers claim that the main

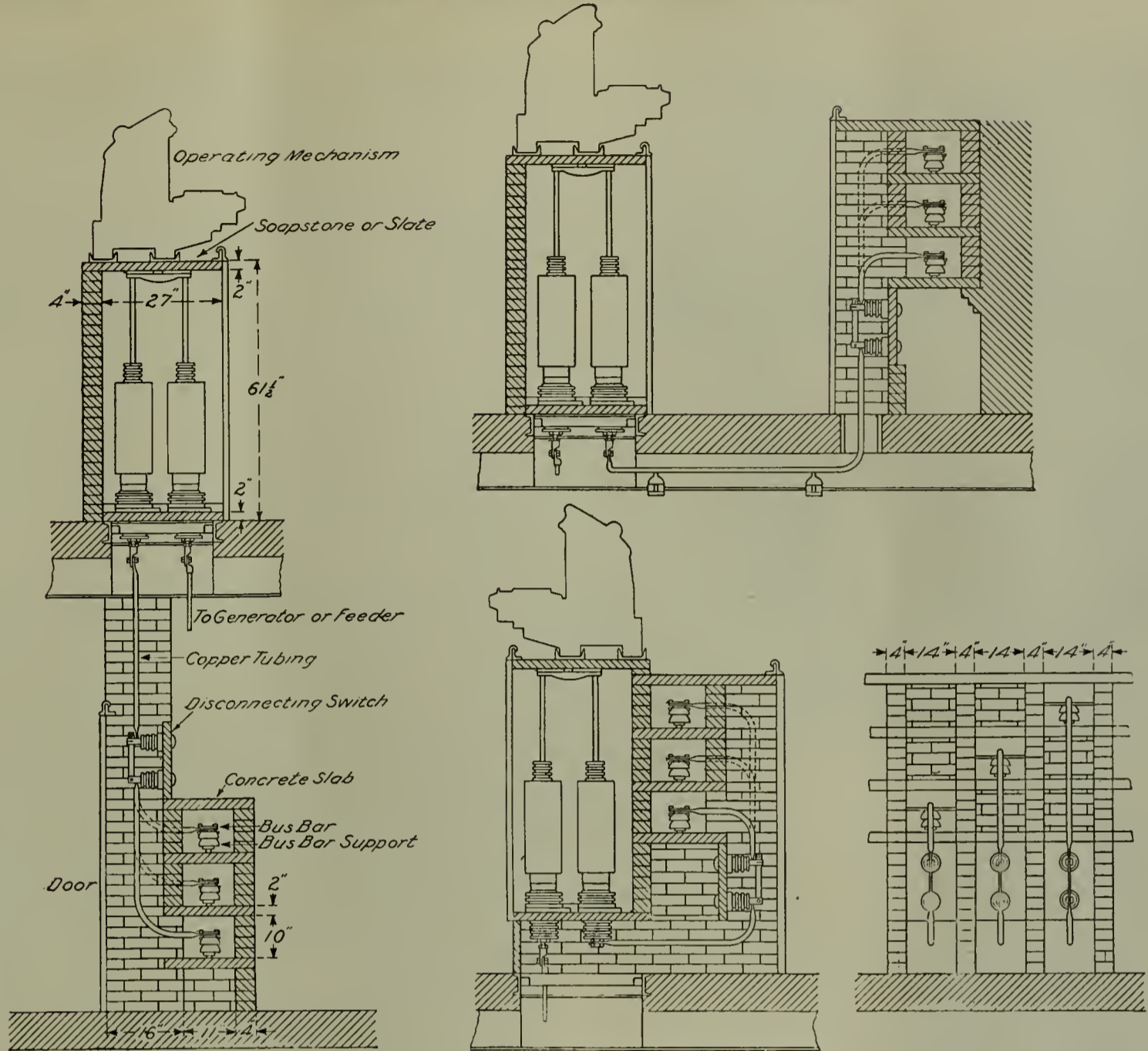

FIG. 16.—ARRANGEMENT OF BUS BARS FOR MOTOR-OPERATED OIL SWITCHES, 13,200 VOLTS, GENERAL ELECTRIC CO., SCHENECTADY, N. Y.

wiring in large stations should be enclosed no matter how high the voltage, while others claim the wiring should be open when the voltage exceeds 33,000.

The enclosed system of wiring is intended to provide additional protection to the operator and additional security against breakdown, due to some conducting material getting across the bus bars.

The open system of wiring is preferred by engineers who consider that fireproof barriers and cellular construction are necessary on large capacity circuits of low voltage, but unnecessary on higher voltage circuits, as the violence of the arc and the destructive effects of a short circuit depend on the amount of heat developed by the current available at the point of short circuit, or for the same amount of power are inversely proportional to the square of the voltage.

It is claimed that fireproof barriers offer a more or less perfect ground for high-voltage circuits, and that the higher the voltage the more perfect the ground. With barriers, the striking distance to ground has to be re-

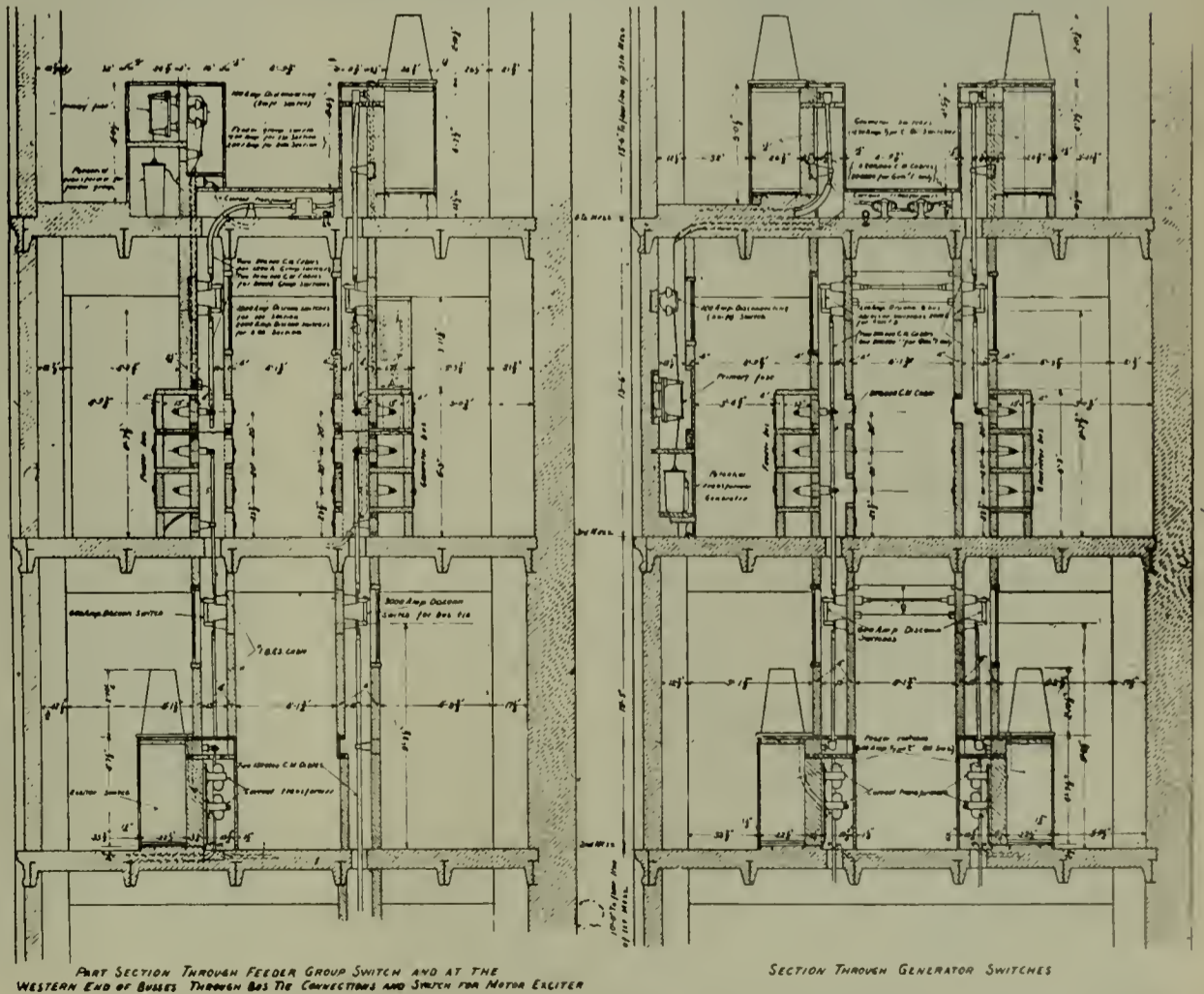

FIG. 17.—ARRANGEMENT OF BUS BARS FOR SOLENOID-OPERATED OIL CIRCUIT-BREAKERS, 11,000 VOLTS, GENERAL ELECTRIC CO., SCHENECTADY, N. Y.

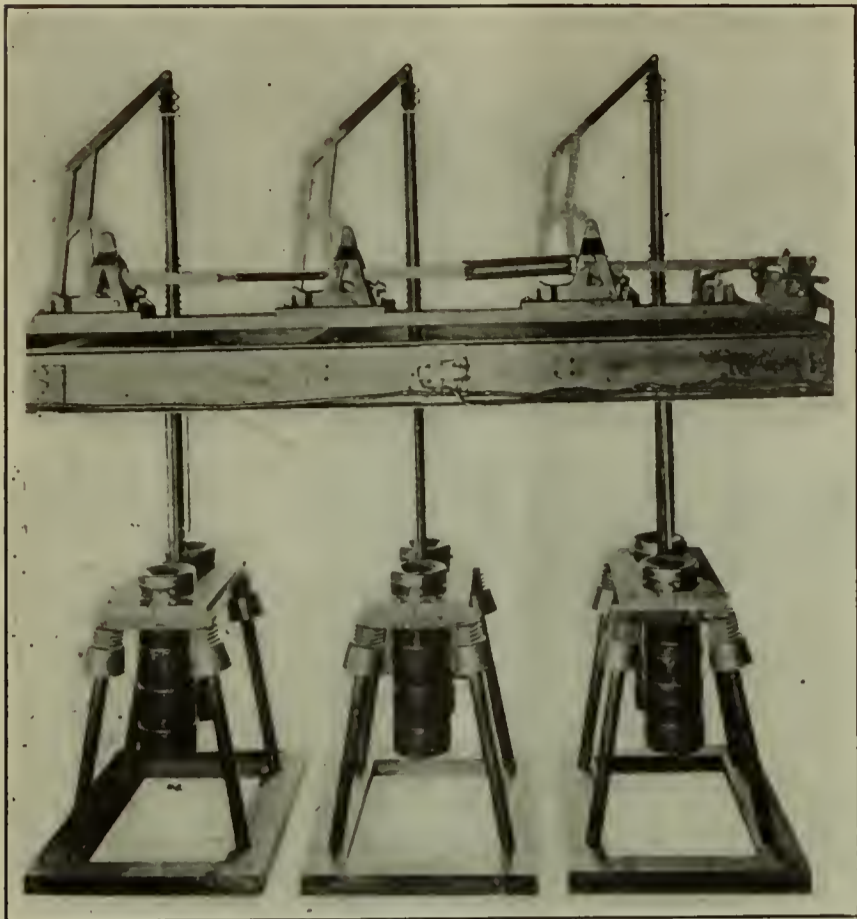

FIG. 18.—T.P. 60,000 VOLT, H-4 OIL SWITCH, GENERAL ELECTRIC CO., SCHENECTADY, N. Y.

duced 50 per cent., or more, over what could be obtained with open wiring in the same space.

Enclosed wiring usually requires a more expensive building and makes the inspection and repair of bus bars, wiring, disconnecting switches, far more difficult. This increased difficulty of inspection prevents incipient trouble being noticed so readily.

Owing to the difference of opinion regarding the advisability of enclosing the high-tension bus bars and wiring, the oil switches designed for voltages above 33,000 are arranged to suit the two different methods of wiring. One type is essentially a bottom-connected motor-operated switch, intended for mounting in a masonry structure with each pole in a separate fireproof compartment, and each contact in a separate pot, with terminals at the bottom of the pot. The other type is essentially a top-connected, solenoid-operated, self-contained breaker, with the two contacts forming one pole in the same tank.

Fig. 18 shows a motor-operated, bottom-connected oil switch, used in the 60,000-volt circuits at the Toronto receiving station of the Toronto & Niagara Power Company. The switch is arranged with two wooden pots about 10 in. diameter, 32 in. long, forming one pole of the breaker mounted in a horizontal wooden platform supported at the four corners by porcelain insulators mounted on wooden rods. Each pole of the switch is in a fireproof masonry compartment about three feet wide, four feet six inches deep, and seven feet six inches high, open at the bottom for the incoming and outgoing leads.

The circuit between the terminals in the bottom of the two pots forming one pole of the switch is made through metal plunger rods attached to a metal cross-piece, external to the tanks. A motor-operated mechanism connecting through wooden rods to the metal cross-piece moves it and the plungers vertically upward to open the circuit. The exposed metal parts above the tank, and the bare terminals below, necessitate the enclosing of the switch in a masonry structure for the protection of the attendant. Doors are provided for each compartment of the structure to permit the ready inspec-

tion of the tanks, etc., but the removal or breaking of a door leaves these live metal parts a source of danger.

This type of breaker works in well with an enclosed system of bus bars, located on the floor below the breakers. It requires a comparatively small amount of oil, and the operating mechanism, consisting of a motor with suitable rods, clutches, etc., is located on a base above the pot, supported by the walls of the compartment, and entirely independent of the outgoing leads.

In addition to the necessity of a masonry structure for this breaker, there is a certain amount of disadvantage in the fact that the mechanism, motor, etc., is at such a height from the floor that it is necessary for the attendant to stand on a ladder to oil the motor or adjust the mechanism. In common with all other types of bottom-connected breakers, this one has no oil gauges, and the sediment in the oil tends to settle on the contacts. A certain amount of trouble is also experienced in securing and maintaining an oil-tight joint, where the metal contact and terminal pass through the bottom of the wooden oil pots.

The solenoid-operated, top-connected breaker is made in two styles, the smaller to handle circuits up to 20,000 kw., three-phase, at 66,000 or 88,000 volts, and the latter to handle circuits of an unlimited amount of power.

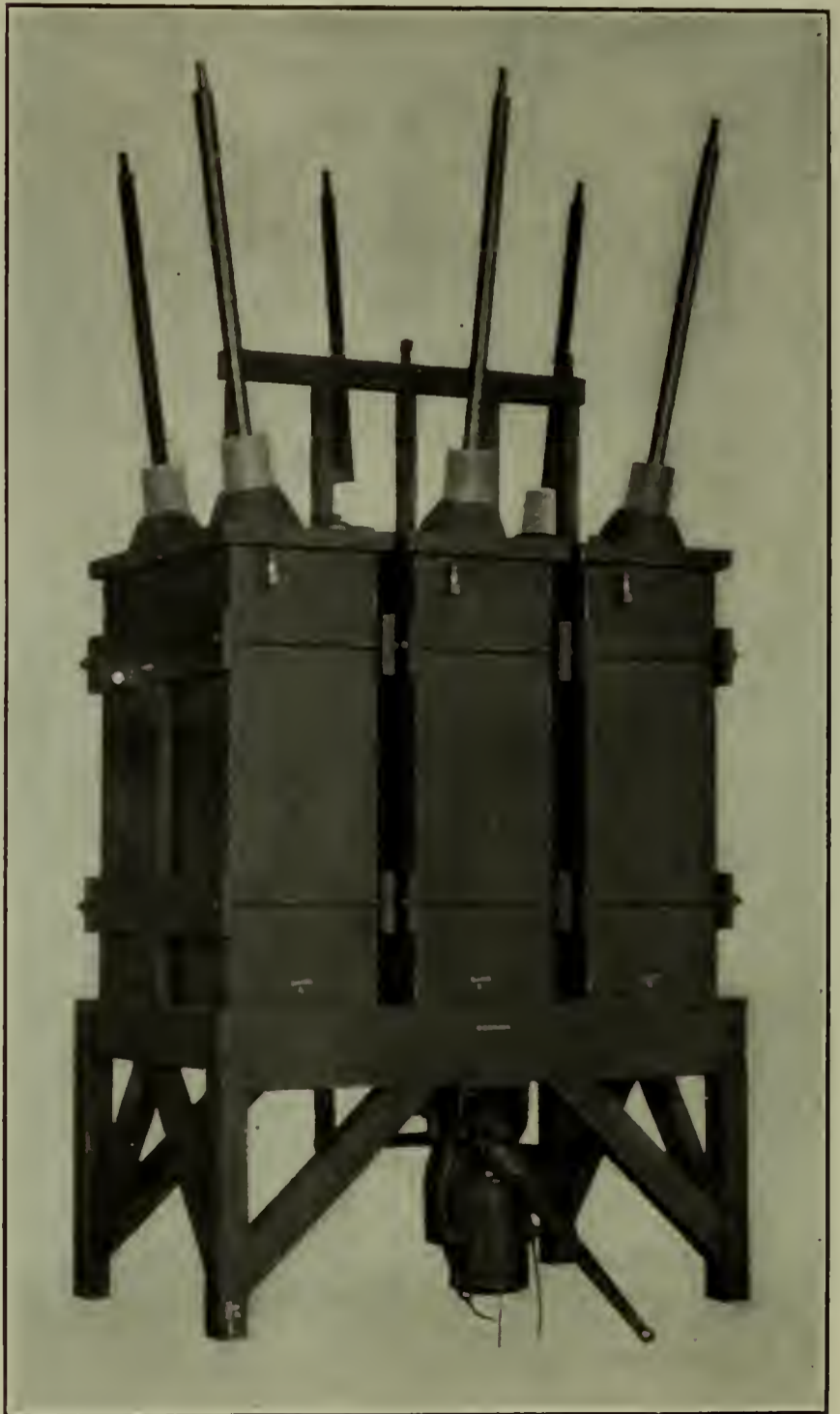

FIG. 19.—SMALL SOLENOID-OPERATED OIL CIRCUIT-BREAKER FOR 60,000 VOLTS, WESTINGHOUSE ELECTRIC & MFG. CO., PITTSBURG, PA.



Fig. 19 shows the smaller type of solenoid-operated breaker for 66,000 volts service on circuits of 20,000 kw., while a modification of this breaker

were in a separate tank. The operating solenoid, with the toggle mechanism, etc., is located near the floor in a readily accessible position, and the

carried just beyond the center, and is tripped out by the armature of the tripping coil striking the toggle and knocking it backward—thus allowing the breaker to open by gravity. All of the live metal parts are completely submerged in oil, while the leads brought out through the top of the case are heavily insulated. As the tanks, mechanism, etc., are grounded for the protection of the attendant, there is no necessity of enclosing these breakers in a masonry compartment, and they are, therefore, made entirely self-contained. The tops of the tanks are made so that the terminals, contacts, etc., can be readily got at for

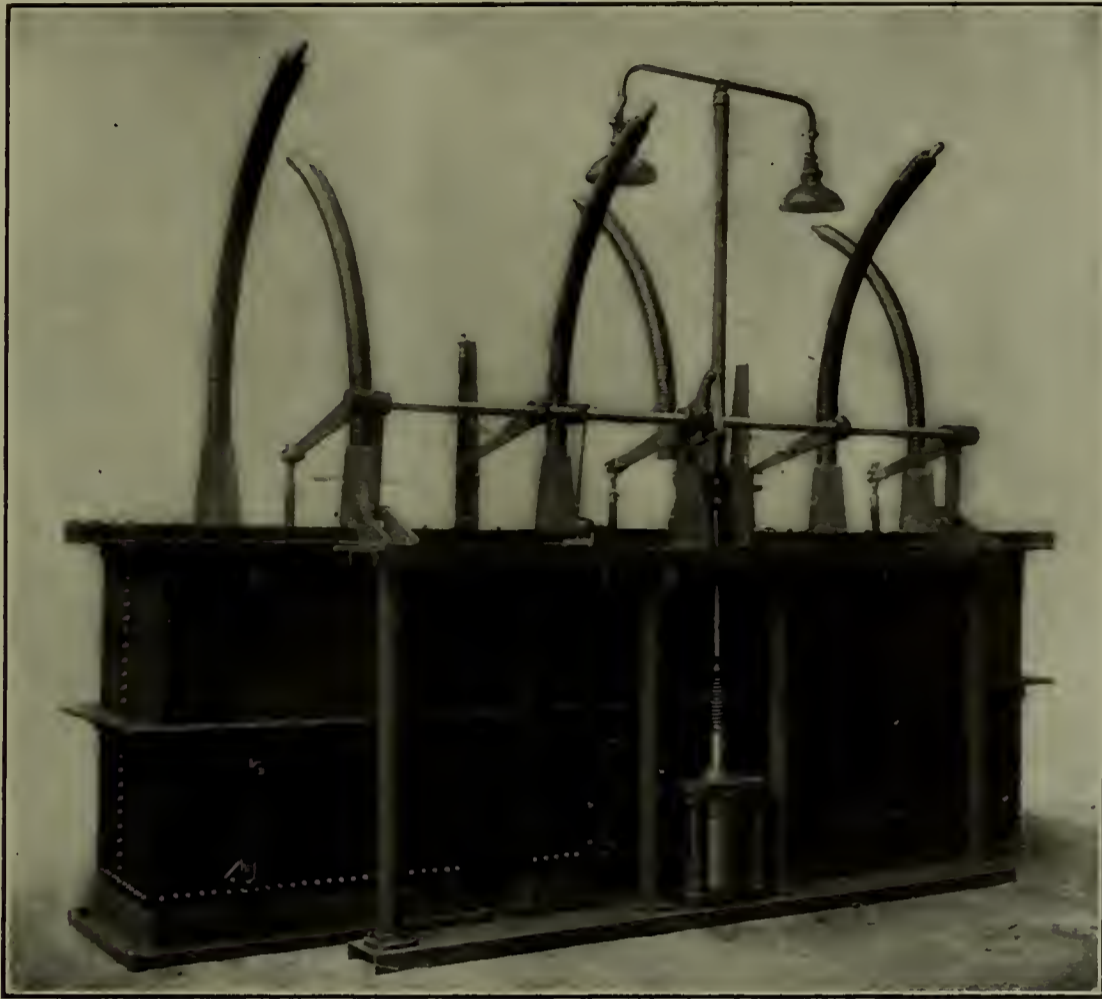

FIG. 20.—LARGE SOLENOID-OPERATED OIL CIRCUIT-BREAKER FOR 66,000 VOLTS, WESTINGHOUSE ELECTRIC & MFG. CO., PITTSBURG, PA.

is in service on 88,000 volts, with a capacity of 40,000 kw. The tanks of this breaker are of metal with insulated lining, and the two stationary contacts forming each pole are located under the oil near the top of the tank,

hand-closing lever can be attached to the mechanism in a simple and reliable manner.

Fig. 20 shows the large solenoid-operated breaker of unlimited capacity, which is used on the circuits of the Ontario Power Company, and guaranteed to open satisfactorily under any condition of overload or short circuit that might exist in a plant having 200,000 kw. on the bus bars at 66,000 volts. Modifications of this breaker have been designed for 110,000- and 132,000-volt service. The tanks of this breaker are made of boiler iron lined with insulating material, and the entire construction is exceedingly rugged and well suited to the severe operating conditions it is guaranteed to handle. The operating solenoid of this breaker is located near the floor, and all of the mechanism is readily accessible.

In the breakers shown in Fig. 19 and 20, the circuit between the stationary contacts near the top of the tanks is completed by plungers connected to a crossarm, and moving vertically downward to open the circuit. These crossarms are connected by wooden rods to a toggle mechanism, operated by a single direct pull solenoid. The breaker is held in the closed position by the toggle being



FIG. 21.—66,000 VOLT DISCONNECTING SWITCH, WESTINGHOUSE ELEC. & MFG. CO., PITTSBURG, PA.

where sediment cannot settle on them. These contacts are separated by barriers under the oil, so the same result is secured as though each contact



FIG. 22.—88,000 VOLT OIL-IMMERSED CHOKE COIL, WESTINGHOUSE ELEC. & MFG. CO., PITTSBURG, PA.

inspection, repair or replacement. Each tank is provided with a gauge glass so that the height and condition of the oil can be ascertained.

The various oil switches and breakers previously described can be made either automatic or non-automatic. The automatic feature can be obtained either by a series trip, a series relay

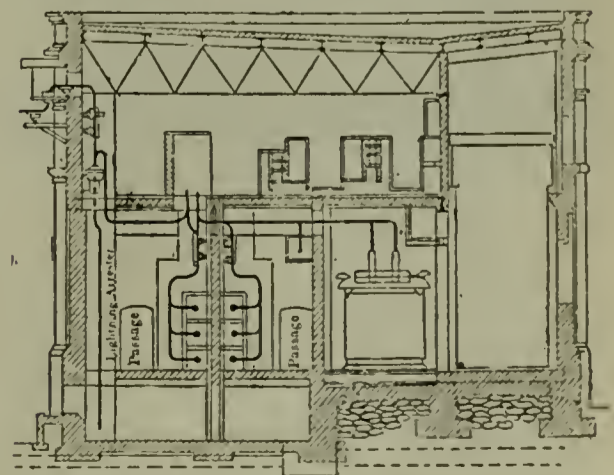

FIG. 23.—66,000 VOLT STATION WITH ENCLOSED BUS BARS, TORONTO TERMINAL STATION, TORONTO, CANADA.

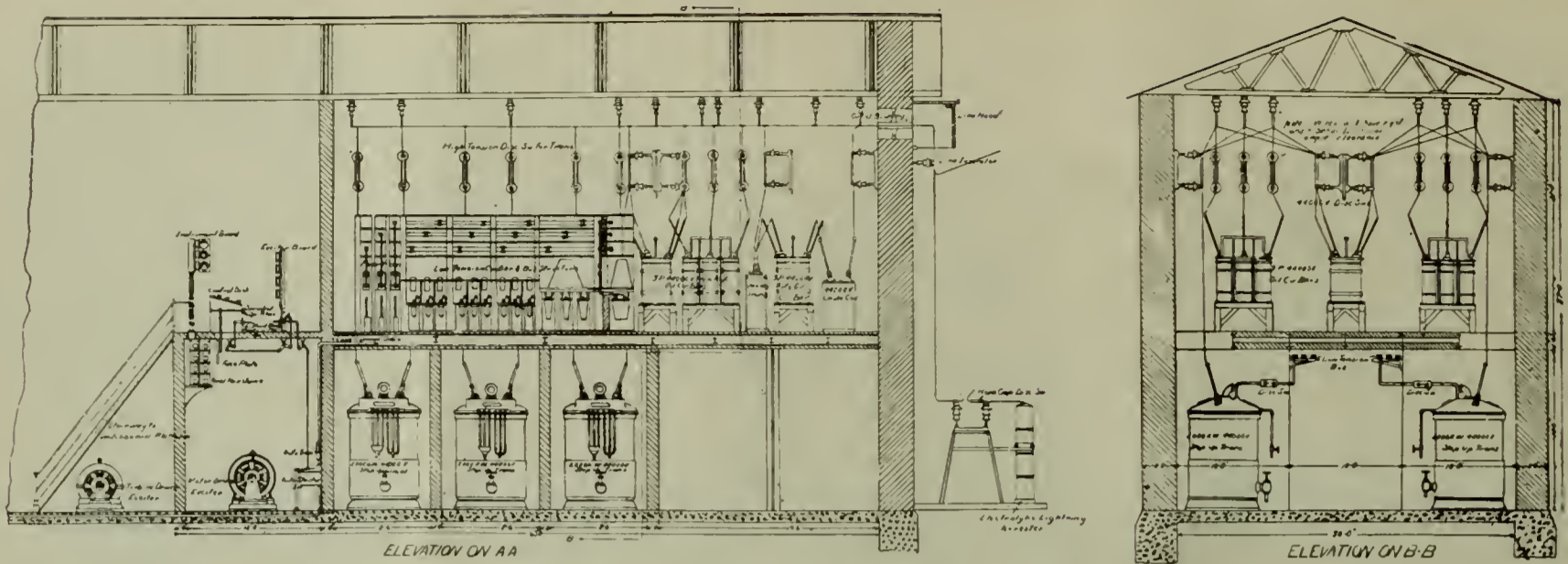

FIG. 24.—44,000 VOLT STATION WITH OPEN BUS BARS.

THE ONTARIO POWER COMPANY  
CROSS SECTION OF DISTRIBUTING STATION

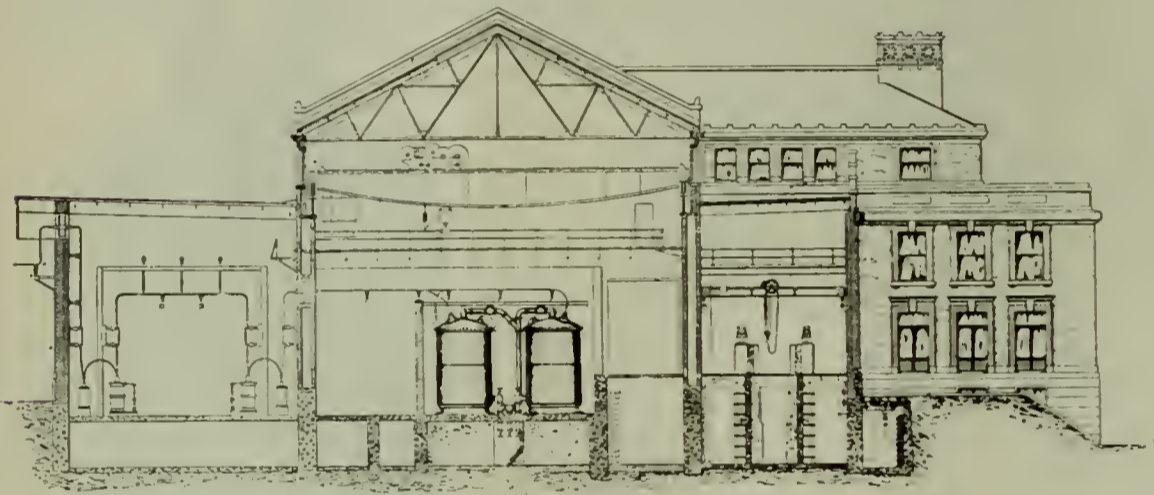

FIG. 25.—66,000 VOLT STATION WITH OPEN BUS BARS, ONTARIO POWER CO., ONTARIO, CANADA.

some type are provided for the purpose of cutting out a damaged line without affecting the other lines. Where two stations are tied together, series transformers are sometimes placed on each end of each line, with their secondaries connected together in such a manner that if the current leaving one station does not all reach the other station, suitable relays will be actuated to cut out the defective tie line at each end.

DISCONNECTING SWITCHES.

In all high-tension circuits for voltages above 33,000, the disconnecting switches almost invariably consist of knife switches mounted on high-tension line insulators as shown in Fig. 21, which illustrates a 60,000-volt disconnecting switch intended for indoor service. As may be noted, a project-

or a relay operated from series transformers. With the series trip, or series relay, straight overload protection with or without a time limit can be obtained, but it is almost impossible to secure any differential or reverse current action without the use of series transformers.

Opinions differ on the question of automatic or non-automatic breakers in various circuits, but usual practice is about as follows: Generator breakers are made non-automatic, or provided with reverse-current relays. The breakers for the low-tension side of step-up transformers, or the high-tension side of step-down transformers, are made overload, while those on the secondary side of the same transformers are made non-automatic. Occasionally, differential relays are provided to trip out both high- and low-tension breakers in case of an internal short circuit, or a ground in the winding of a transformer. On outgoing transmission lines overload relays are usually furnished, while on incoming lines operating in multiple reverse-current relays, or selective relays, of

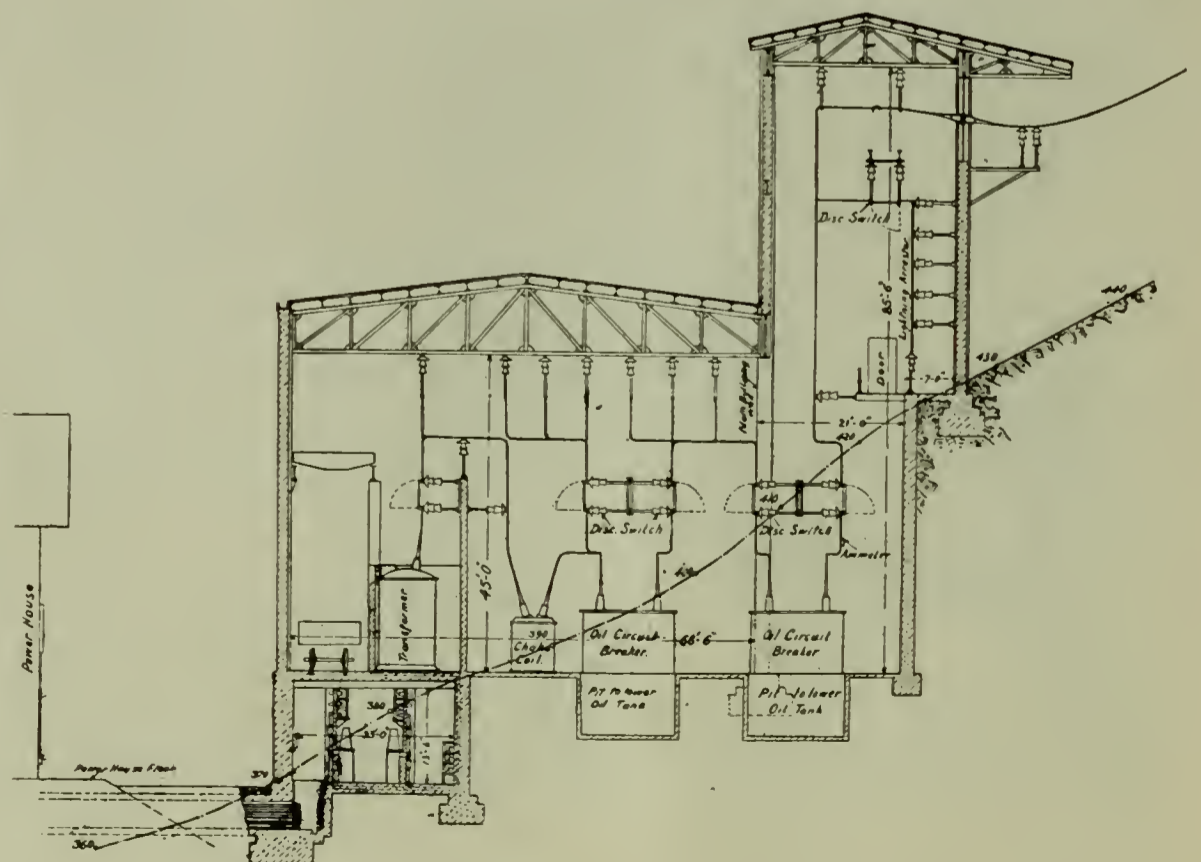

FIG. 26.—110,000 VOLT STATION WITH OPEN BUS BARS.

ing arm is provided so that the station attendant can operate them by means of a direct pull from below. A similar switch has been designed

amount of choking effect is permissible, an open helical coil, mounted on line insulators, can be used. Such a choke coil can be made of aluminum

rent passes through an oil-immersed current transformer, two 60,000-volt oil switches, 60,000-volt bus bars, step-down transformers, two 12,000-volt oil switches to the 12,000-volt bus bars. In the incoming line circuit the connections from the line oil switch pass to a disconnecting switch by means of which it is joined to a separate short bus bar, and this short bus bar may be joined by the other knife switches, either to another oil switch and then to the regular 60,000-volt bus bars, or else to another oil switch, and then to the primary coils of the transformers. By this combination of switches a very flexible arrangement of lines, transformers and bus bars is secured.

The 60,000-volt bus bars and wiring are enclosed in brick and masonry compartments on the floor below the breakers, and apart from the expense of such a construction, there is the difficulty of inspection and repairs, and the necessity of going to another floor to pull the disconnecting switches used for isolating the various oil switches.

Fig. 24 shows a section and elevation taken through the transformers of a station containing six 2000-kw. generators, six 2000-kw., single-phase, step-up transformers, and two 44,000-volt, three-phase transmission lines. The control desk and instrument frame are located on a gallery overlooking the generator room in such a manner that the switchboard attendant at the control desk can readily see the generators. All of the high-tension wiring, bus bars and connections are in plain sight and readily accessible for inspection and repairs.

Fig. 25 shows a section through the transformer room of the Ontario

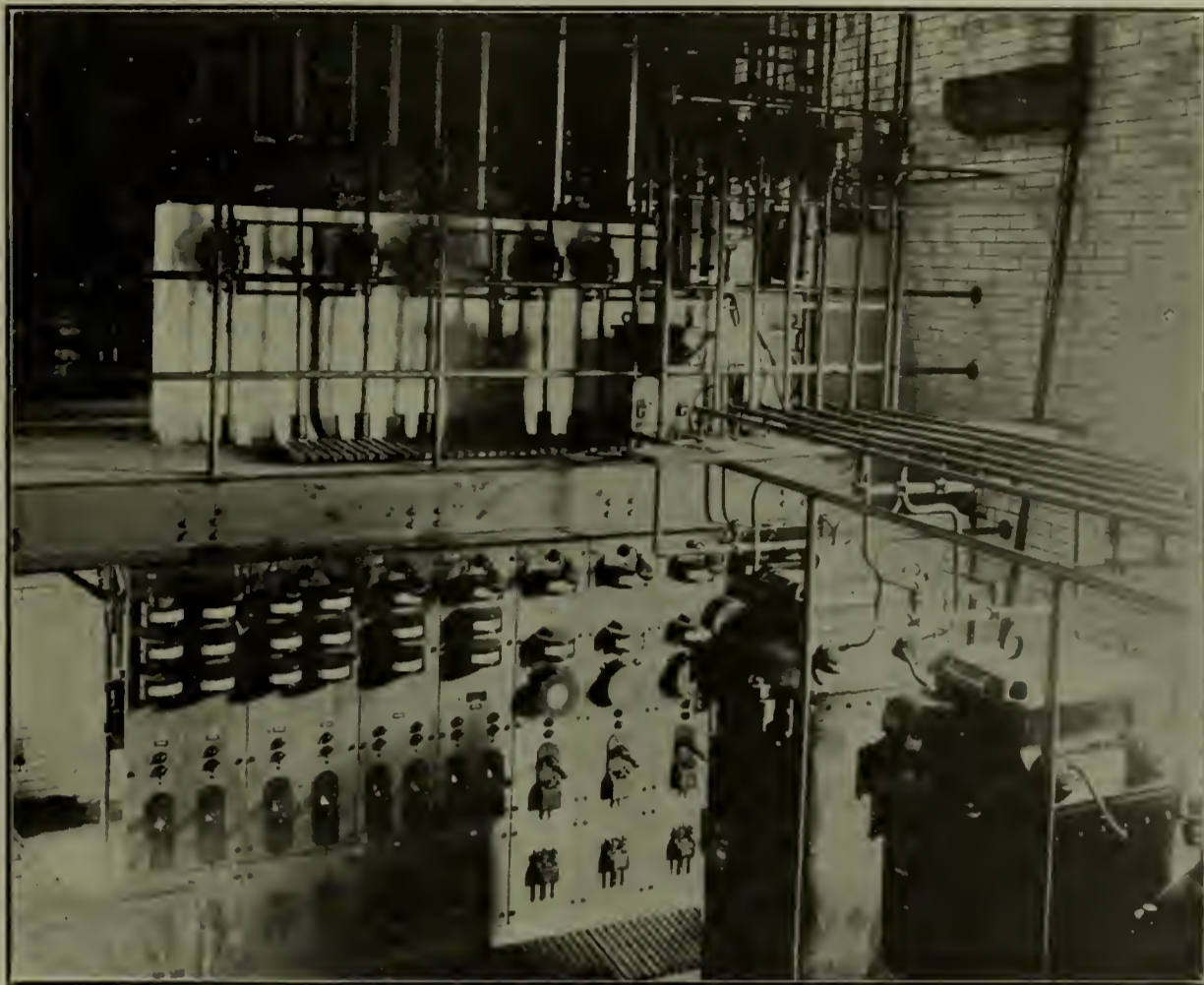

FIG. 27—12,000 VOLT SWITCHBOARD, FULLERTON AVENUE STATION, WESTERN ELECTRIC CO., CHICAGO ILL.

for outdoor service, and where the switches are to be located in inaccessible places, they can be arranged for operation by means of compressed air, or a solenoid- or motor-driven mechanism.

#### PROTECTIVE DEVICES.

For high-tension circuits, choke coil and lightning arresters are provided to furnish protection against lightning and static disturbances of various kinds.

Choke coils for such circuits are usually made in the form of a flat spiral for circuits up to about 25,000 volts, while for higher voltages either the oil-immersed type or the open helical type can be supplied. As a rule, the strain developed across adjacent turns of a choke coil in a high-tension circuit is so great that when the coil performs the function normally expected of it, oil insulation seems to be necessary to obtain the best results.

Fig. 22 shows an oil-immersed choke for use on an 88,000-volt transmission circuit, where the lightning conditions are particularly severe and where the maximum amount of protection possible was desired, owing to the importance of the circuits to be protected. Where lightning conditions are less severe and a smaller

rod with a carrying capacity of 200 amperes, wound into a helix 15 in. diameter with 20 turns, and mounted on high-tension insulators. This coil can, of course, be mounted in any position and connected directly in the main wiring. If necessary, it can be arranged for outdoor mounting.

Lightning arresters for high-tension lines are made either of the low equivalent multi-gap type, or of the electrolytic type, and as these have been often discussed and described, there is no necessity of digressing in this place about them. The electrolytic type of arrester seems to be growing in favor, largely due to the fact that it is suitable for outdoor service.

The Toronto receiving station of the Toronto-Niagara Power Company, Fig. 23, is a typical 66,000-volt station, with enclosed bus bars and bottom-connected oil circuit-breakers arranged for the control of four 60,000-volt, three-phase incoming lines, each of 7500 kw., and four banks of step-down transformers, with provision for a fifth bank.

The incoming line passes through a choke coil consisting of 19½ turns No. 0000 bare copper wire wound in the form of a compressed helix, and supported on high-tension line insulators. From the choke coil the cur-

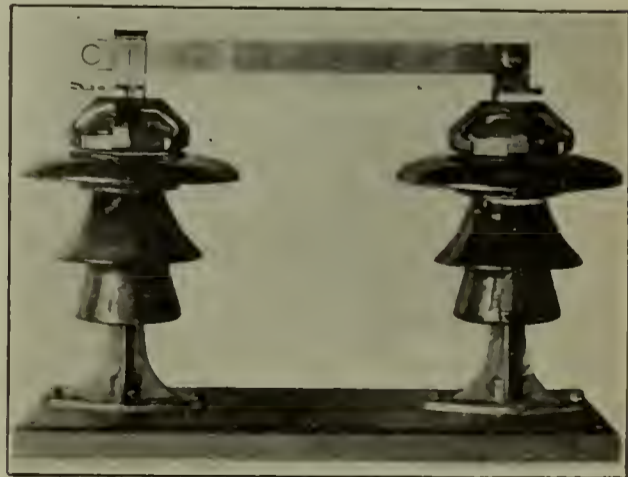

FIG. 28.—60,000 VOLT, 100 AMPERE, TYPE L, FORM G-3 DISCONNECTING SWITCH.

Power Company at Niagara Falls, Ontario. In this station self-contained, top-connected, oil circuit-breakers are used with the bus bars, and wiring mounted in the open in plain sight above the breakers. The disconnecting knife switches are placed directly above the oil circuit-breakers, which they isolate, and may

be pulled by means of a long wooden pole from the floor in front of the breaker. With such an arrangement, the inspection and repair of the high-tension equipment is comparatively simple.

Fig. 26 shows a section through the transformer and switching house of a plant that will ultimately have ten 5000 kw., 6600-volt, three-phase generators, 12 4000 kw., single-phase, step-up transformers for distributing power over four 110,000-volt transmission lines. The building is located on the side of a hill, and all of the circuit-breakers, disconnecting switches, bus bars and connections can be operated and inspected from the same floor.

As may be noted from Fig. 23-26, a large amount of space, and consequently an expensive building, is required to accommodate the transformers, circuit-breakers, disconnecting switches, bus bars, etc., and there seems to be a tendency to work towards outdoor stations for very high voltage plants where the climate is not too severe.

On the lines of the Niagara, Lockport & Ontario Power Company, the 60,000-volt bus bars and the lightning arresters are placed outdoors, while the breakers, disconnecting switches and transformers are indoors. Outdoor switching stations with knife-switches for sectionalizing bus bars, etc., have been installed in many places, and the time is not far distant when practically all of the apparatus will be located out of doors, and will be of sufficiently rugged design that little or no protection from the weather will be required.

#### A Remarkable Vacuum Pump

The accompanying illustration shows a belt-driven vacuum pump, which is especially designed for high vacuum. The pump, which is located in the plant of the Westinghouse Electric Lamp Co., at Watsessing, N. J., is of the two-stage pattern, arranged with two 12-in. diameter vacuum cylinders, 12-in. stroke, designed for a speed of 100 rev. per min., and under these conditions will produce a vacuum of within 0.02 inches of the barometric height as registered by the mercury gauge. This pump runs continuously under these conditions and the results obtained are remarkable. The pump takes suction directly from a closed receiver, which is piped off to the stands containing the incan-

descent lamps to be exhausted. The large capacity of the pump, together with its great efficiency, particularly adapts it for this class of service. It works strictly on the dry system, as no water is necessary or permitted to

water jacketed. The valves are mechanically operated by eccentrics keyed to the main shaft.

It is interesting to note the difference in the work performed by the intake or suction cylinder and that of

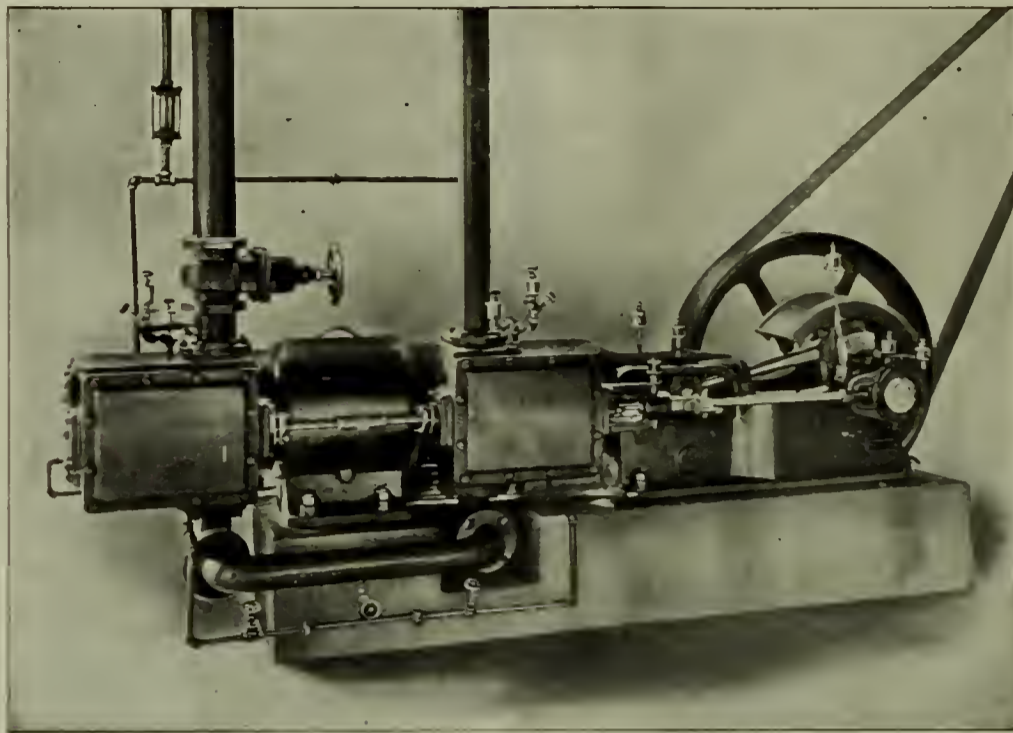

INTERNATIONAL STEAM PUMP—BELT DRIVEN VACUUM PUMP.

enter the cylinders. It is also adapted for all usages where exceedingly high vacuum is desirable, namely, in connection with the evaporative processes of sugar refineries, distilling plants,

the final cylinder, as shown by the set of indicator cards. The final cylinder does by far the majority of the work, while the intake cylinder produces just that fraction of an inch of vacuum, which reduces the resultant pressure to practically absolute zero. This machine is manufactured in larger and smaller sizes suitable for various capacities, and is designed and patented by the Blake & Knowles Steam Pump Works, 115 Broadway, New York City.

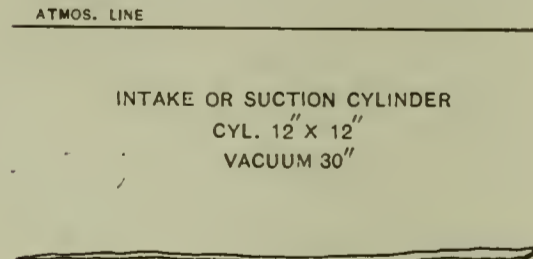
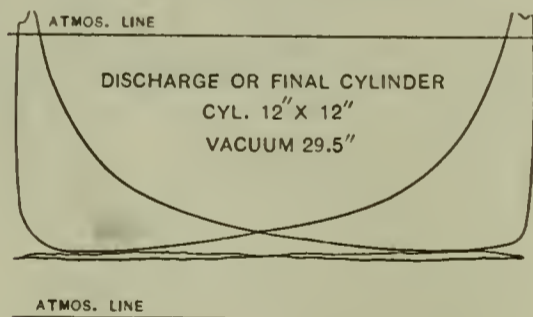

chemical and dye works, glue works, salt works, soap works, the manufacture of prepared foods, medicines, essence, glycerine, etc., preserving processes, the production of high vacuum in central steam condensing systems and steam turbine work. These vacuum pumps are also built with steam cylinders for direct steam drive, also arranged with extended bases and gearing for electric motor. The vacuum cylinders are thoroughly

#### A Lamp Game

Lamp salesmen, as well as lawyers, number their shysters. One of them works this game: He goes to a prospective customer who knows little about lamps or electricity and gives him a sample to test. The customer is delighted by its brilliancy and inquires as to the life and price. "We guarantee this to last as long as any lamp on the market, and sell it for 14 cents." What he really has is a lamp burned at 5 to 8 volts above normal, and either not labeled or wrongly labeled. On the strength of this a sale is often made and the lamps last until the bill is paid. After that, who cares? Should any doubt arise in the customer's mind because of the whiteness of the light, he is told that this is a new filament recently invented.

# Overhead Lines

By H. B. GEAR and P. F. WILLIAMS

Commonwealth Edison Co., Chicago.

THE selection of the method of installing a system of distribution overhead or underground is governed by the local conditions prevailing in different parts of a city. Where the character and density of a load are such that continuity of service is of great importance, the lines should be such that the risk of interruption will be reduced to a minimum, and a greater expense is justifiable to accomplish this result. In such sections the use of underground construction is, therefore, common. Where the load is more scattered and the revenue

The use of poles and cross-arms for the support of overhead lines had already been well developed in connection with telegraph work, and it therefore only remained for the electric lighting engineers to make slight modifications in the spacing of the wires and in the type of insulator employed.

The development of series arc lighting systems for street lighting preceded somewhat the overhead Edison lines and the alternating-current primary distributing systems.

The most common form of overhead construction in American prac-

a very substantial and rigid pole. The sap wood, which is from one to 1½ inches thick, is soft enough to make the use of spurs easy in climbing. The surface of the pole is comparatively free from knots, and it usually grows fairly straight.

The Western cedar, which grows principally in Idaho, has a natural taper of about one inch in eight to 10 ft. of length. For the same size pole top the diameter of the butt is therefore small. The sap wood is about one inch thick, and is a larger proportion of the total cross-section at the ground line. The decay of the sap wood, which takes place first, therefore weakens these poles sooner than Michigan cedar and other poles of the same height and top diameter. The surface of Western cedar is smoother than that of the Michigan cedar, and they are very straight and neat in appearance. The weight of the wood is light, and is therefore easy to handle in erecting. It is preferable, on important lines, to use nothing smaller than eight-inch tops with these poles in order to get proper diameter at the ground line.

The chestnut pole is quite different in character from either of the cedar poles. The sap wood is thin and the specific gravity of the wood is high on account of its hard and densely formed fiber. This characteristic, together with the fact that the surface of the pole is irregular and knotted, makes the work of shaving difficult, and the appearance of the pole is not as good as cedar. The thin hard layer of sap wood makes the use of spurs

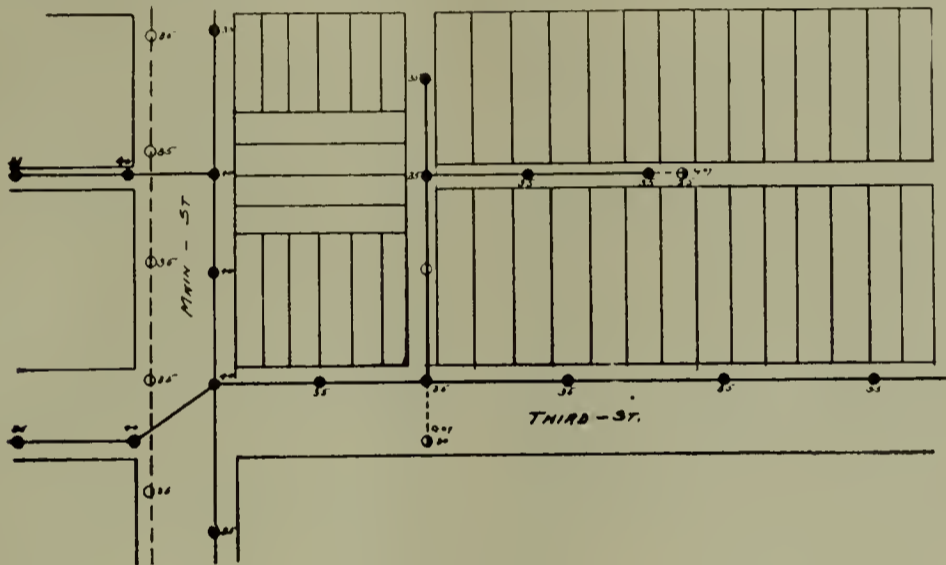

Fig. 1.

derived per square mile is correspondingly smaller, less expensive construction must be employed and overhead lines are, therefore, generally found. The terms of the franchise under which the business is operated may also fix the character of the construction in certain districts.

In the larger cities public sentiment against the presence of pole lines may be such that the lines are placed underground on important streets somewhat in advance of the time when the development of the business would demand it.

All of these conditions are found in large systems, and some of them govern the class of construction in every system.

The earlier Edison systems were placed underground because of the fact that they gave service in crowded districts, where overhead lines would not be tolerated.

As soon as these systems were extended to the smaller cities and to outlying portions of the larger ones, overhead construction was resorted to.

tice consists of the use of wooden poles carrying the wires on cross-arms and pins. Iron poles are objectionable for general distribution work on account of the risk incurred by linemen in handling high-tension circuits alive while connecting transformers and doing other work. Iron poles are in use in some of the larger cities for street lighting circuits, which are not alive during the daylight hours, and are so operated that it is not necessary to do any work on them while they are alive. The cost of iron poles is several times that of wooden poles, which is a further disadvantage where the investment must be limited.

The woods which are best suited by natural growth for pole work in America are the Michigan cedar, Western cedar, chestnut, pine and cypress. Other woods are used, but only to a limited extent.

The Michigan cedar grows with a natural taper of about one inch in diameter to every five feet of length, except near the butt of the pole, where it flares out somewhat larger, making

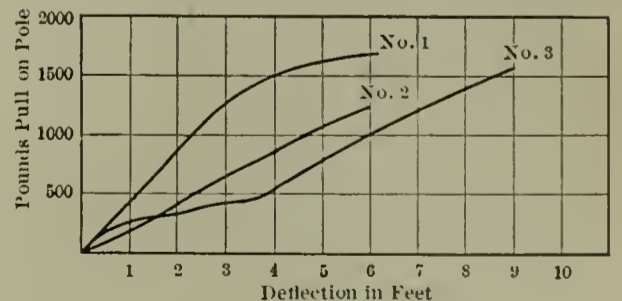

Fig. 2.

difficult also. Chestnut is not as good an insulator as other kinds of wood, which tends to increase the difficulty of handling live circuits. It grows with a natural taper of about one inch in six or eight feet.

Pine and cypress poles are more like cedar in their general characteristics of weight and strength. Their

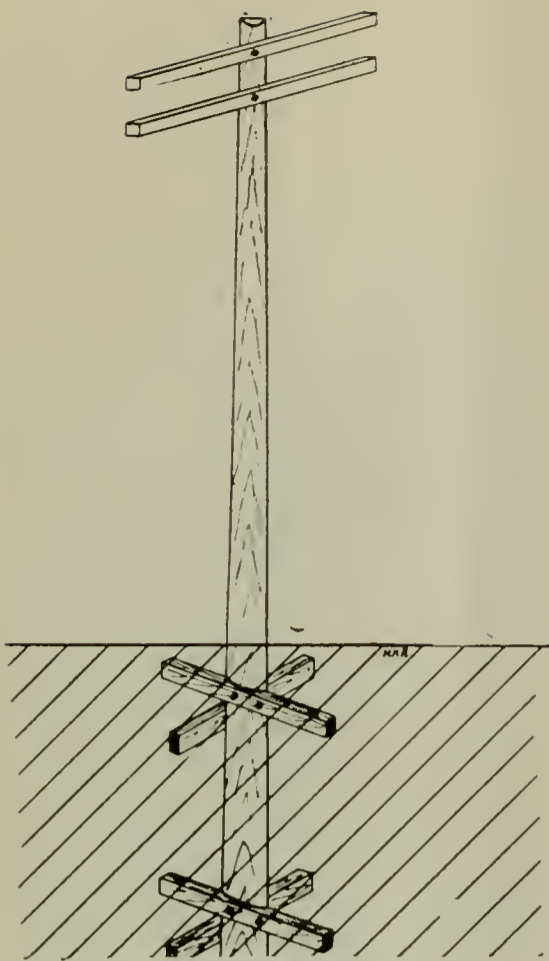

Fig. 3.

use is limited to sections of the country where the timber is native, as their life is comparatively short if moved to other climates, and is not as long as cedar or chestnut in any event.

In general, the kind of pole used is governed by the proximity of the source of supply. In the South, pine, cypress and chestnut are commonly found. In the East and Middle States, Michigan cedar and chestnut are used, while in the West, Western and Michigan cedar are general, except on the Pacific coast, where California redwood and some other native woods are used very generally.

The strength of the poles selected for general distribution must be gauged by the importance of the lines they are to carry and by the local conditions which may affect the facilities for guying. Practice has become pretty well standardized by years of experience, and the selection of poles is as often accomplished by the experienced eye of a foreman who has grown up in the business as by theoretical calculations as to the ultimate breaking strength of a given sized pole under a given load.

For special cases, however, it is important to apply theoretical calculations as a check on the strength of poles which are to carry unusual strains, and the formulas for calculating stresses should be familiar to the designer of overhead distributing lines.

The strain acting on a pole tending to pull it over at the top is the most important one to be considered. This

strain causes a tension in the fiber of the wood on one side of the pole and a compression on the opposite side. For a round pole the stress is

$$S = \frac{32 PL}{3.14 (d)^3}$$

in which P is the equivalent pull in lbs. at the distance, L in feet above ground, and d is the diameter in feet at the ground line, or

$$d^3 = \frac{32 PL}{3.14 S}$$

The strain S, at which any wood may safely be worked, is not more than 10 to 12 per cent. of its ultimate breaking strength, as determined by tests of the timber in the form of poles. This high factor of safety is necessary because of the differences in the strength of different poles of the same kind of wood, to the possibility of excessive strains being placed on poles in unusual emergencies, such as the burning off of all the wires of a span, and to the fact that as the pole remains in service year after year, its strength at the ground line is lessened by decay, thus reducing the reserve available for an emergency.

It is found from tests that cedar, redwood and pine each have an ultimate breaking strength of about 7000 lbs. per square inch when tested in the form of large timbers. Chestnut is slightly stronger, having a strength of 8000 lbs. per square inch.

In using the foregoing formula, the value of S should therefore be taken at about one-tenth of these breaking strengths, or at 700 to 800 lbs.

EXAMPLE.

If a self-sustained pole is to support a line which exerts a pull of 1000 lbs.

at a height of 30 ft. above the ground, what should be its diameter at the ground line to carry the strain safely?

Let S be  $\frac{1}{10}$  of 8000=800. P=1000, L=360 in.

$$(d)^3 = \frac{32 \times 1000 \times 360}{3.14 \times 800} = 4584$$

from which d=16.5 in. This would call for the use of a pole 35 ft. long, with a butt 16 in. at the ground line and a top diameter of 9 to 10 in., in Michigan cedar, or 12 to 13 in. in Western cedar.

Conditions similar to those assumed above are frequent in city practice, where streets or alleys jog, or where turns are made at right angles, which cannot be supported by a guy, as in the case of the line branching from Main Street to the alley east of Third Street, in Fig. 1.

In selecting poles for distributing lines such as those shown in Fig. 1, the poles at corners and turns must be such that they will hold the wires taut for a reasonable period after they are strung. The intermediate poles should have such strength that they will support the weight of any size of transformer up to about 15 kw., and will not pull too much out of line if more service drops are taken from them on one side than on the other.

Service drops are not usually over 75 ft. long, and may be allowed to hang with considerably more deflection than the main line wires. The sidewise pull on a pole, therefore, does not usually exceed 300 lbs. With the services attached at a height of 30 ft., the size of the pole at the ground line

$$\text{should be } (d)^3 = \frac{32 \times 300 \times 360}{3.14 \times 800} =$$

1375; d=11 in. This corresponds to a cedar pole with a 5½-in. to 6-in. top. The use of poles of this size is not permissible in sections where more than one or two service drops are likely to be taken from any pole, as the bending of so slender a pole under the strain pulls the line out of shape and thus increases the strain on the pole.

The curves shown in Fig. 2 are the results of a test on cedar poles to determine their rigidity and strength. No. 1 was a Western cedar pole 35 ft. long, 23 in. in circumference at the

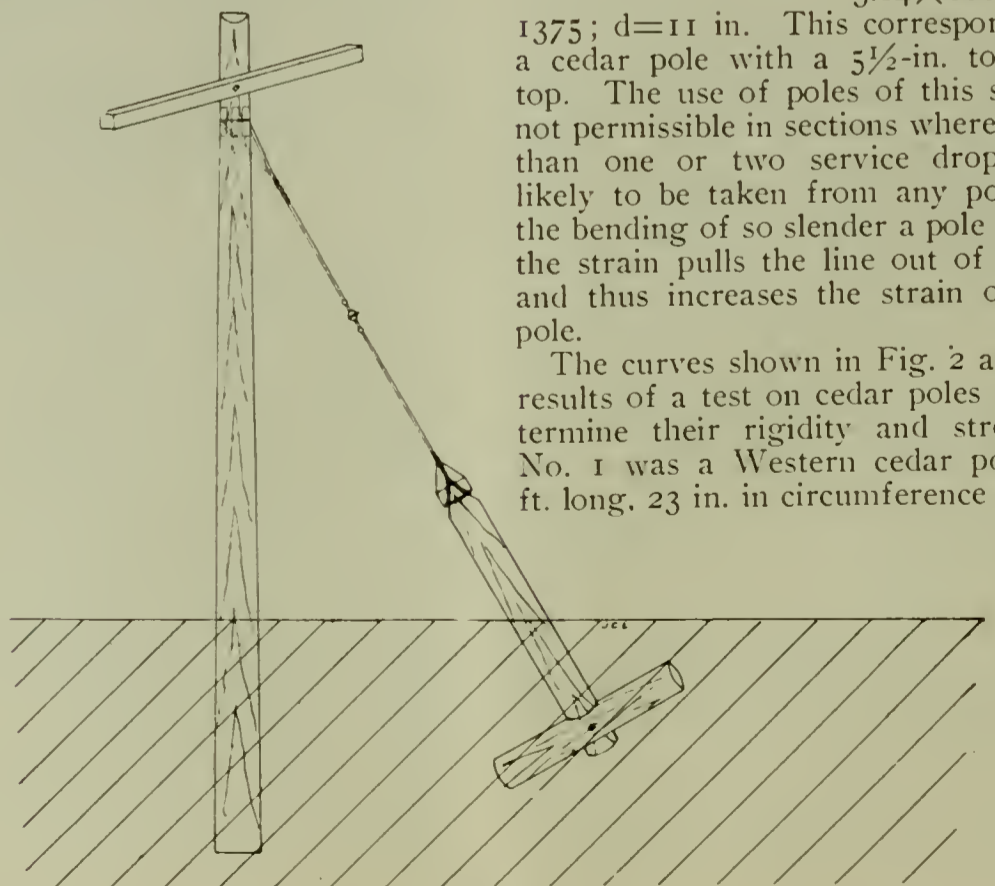

Fig. 4

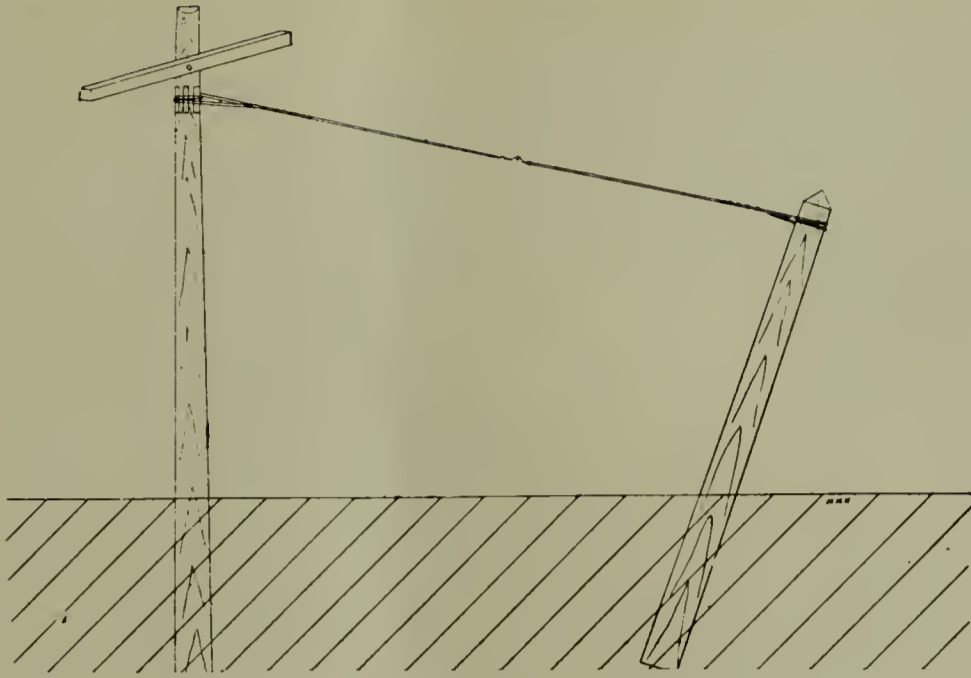

Fig. 5.

top and 37 in. at the ground line. No. 2 and No. 3 were Michigan cedar poles, of approximately the same dimensions. The test was made by securing the pole at the butt and applying a load at the top at right angles to the length of the pole. The end of the curve indicates the point at which rupture occurred in each case; No. 1 being at 1600 lbs., No. 2 at 1200 and No. 3 at 1500. It will be noted that the pull required to deflect the pole 1.5 ft. is much less with the Michigan cedar than with the Western cedar, the latter being the stiffer throughout the test.

A deflection of more than one foot becomes noticeable in the appearance of a line and tends to place additional strain upon the pole. A strain of more than 250 to 300 lbs. should therefore be balanced by a guy attachment or should be supported by a pole of heavier cross-section if guying is impracticable.

It is evident from the test that the use of poles having a top diameter less than seven inches for general distribution is not advisable. In suburban distribution smaller poles are permissible.

The height of the poles selected for distribution purposes must be governed by the requirements of clearance over local obstructions and by the number of cross-arms to be carried on the poles. The presence of other pole lines, of trees, elevated railroad structures, and buildings each require the use of higher poles than would otherwise be necessary at times. Clearance over trees is especially troublesome in residence sections, where trimming will not be permitted. In some cases it is better to go above and in other cases below the trees.

In general, it is not desirable to use poles less than 30 ft. long where primary lines are carried, and in built-up sections a minimum size of 35 ft. is

preferable. Poles of 50 to 70 ft., or more, are sometimes required to give proper clearance and cross-arm space. Where joint construction with a telephone company is used, it is not customary to use poles smaller than 35 ft.

It is not necessary to maintain an entire line of high poles merely to preserve the general level where a part of the line must be elevated to clear obstructions. The use of high poles is to be avoided wherever possible, in view of the cost of installation, the increased danger of failure in time of storm, and the difficulty of handling transformers and service connections.

The length of spans is governed by a number of considerations. Poles should be close enough to keep the deflection of the span within safe limits and to provide a sufficient number of points at which service drops may be taken off, and yet must be so

placed at lot lines to prevent interference with the rights of abutting property owners, and to save expense of moving in case new buildings are erected. The average city lot being about 25 ft. in width, there may be some spans 125 and other 100 ft., or less, in length. It is not advisable to exceed 125 ft. where there are many service drops taken off, as the number of services per pole and their average length is increased, thus placing greater strain on individual poles.

The design of pole lines to withstand wind pressure in a lateral direction must be considered where sections of line are exposed. Fortunately, most of the average pole line distribution is so protected by buildings and trees that it is not subject to the full force of wind-storms. In exposed sections and on transmission lines supplying suburban substations, the force of the wind may be felt at times very greatly, and lines should be built accordingly. The force of a wind-storm is most apt to be an element of danger when it is exerted at right angles to the direction of a line, since there are normally no strains in this direction, and no system of support is provided except for protection from storms.

The pressure of the wind blowing against a surface normal to its direction was found by Langley in a series of experiments made in 1888 to be  $p = .0036 (v)^2$ , in which  $v$  is the velocity of wind in miles per hour, and  $p$  is the lbs. per square foot. From this it is evident that  $p$  is 20 lb. when the wind blows at 75 miles per hr., or 5 lb. at 37.5 miles per hr.

The force exerted upon poles and wires varies with the angle at which

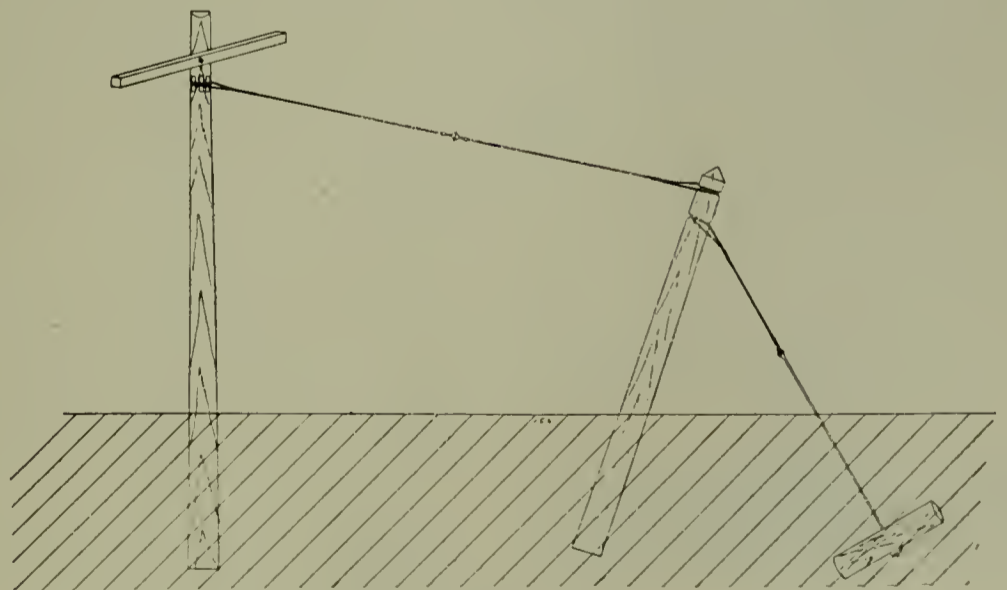

Fig. 6.

spaced that the block, or section, of thoroughfare will be divided into approximately equal span lengths. The spans near self-supported corner poles should be from 75 to 100 ft., if possible, in order to relieve the strain on the corner pole. The poles should be

the wind strikes them, being a maximum at 90 degrees. In figuring the area of surface exposed, allowance must be made for the fact that the surfaces are cylindrical. Theoretically, a cylindrical surface presents but two-thirds as much surface to the

wind as a flat surface of the width of the diameter of the cylinder. A 40-foot pole having a top diameter of seven inches and a butt at the ground line of 14 in., set five feet in the ground, has an average diameter of

sq. ft., the force exerted on each No. 6 wire of a 120-ft. span is  $10 \times 2 = 20$  lb. The force exerted on the pole, due to its own surface, is equivalent to about 100 lb., applied near the top. The total force on the pole at such a

to take place in the spring, when the frost is leaving the ground, and it is sometimes necessary to straighten considerable lengths of pole line every spring, where some system of side supports cannot be readily provided.

Where there is room to excavate a hole 4 to 5 feet square, poles which cannot be guyed can be supported by a double set of plank, as shown in Fig. 3. The pole should be leaned in the direction opposite the strain when it is set, so that as the strain is applied the pole will come up straight and solid. The plank should be three inches thick and 10 to 12 in. wide by four to six feet long, depending on the height of the pole. The upper plank should be kept about a foot below the surface to prevent rapid decay and to give it a solid setting.

Where there is considerable water or quicksand, or where room is not available for the excavation for plank supports, concrete may be tamped about the pole at the bottom and near the surface. When set, this acts as an enlargement of the section of the pole, and thus provides a larger bearing surface against the earth with greater stability.

The expense of the two methods varies with the nature of the soil. Sandy soil where digging is easy, the plank support is somewhat less expensive than concrete, but in clay the concrete is usually cheapest.

The depth at which poles are set must be such that the strains in any direction will not pull the pole over, and will not pull it too far out of line.

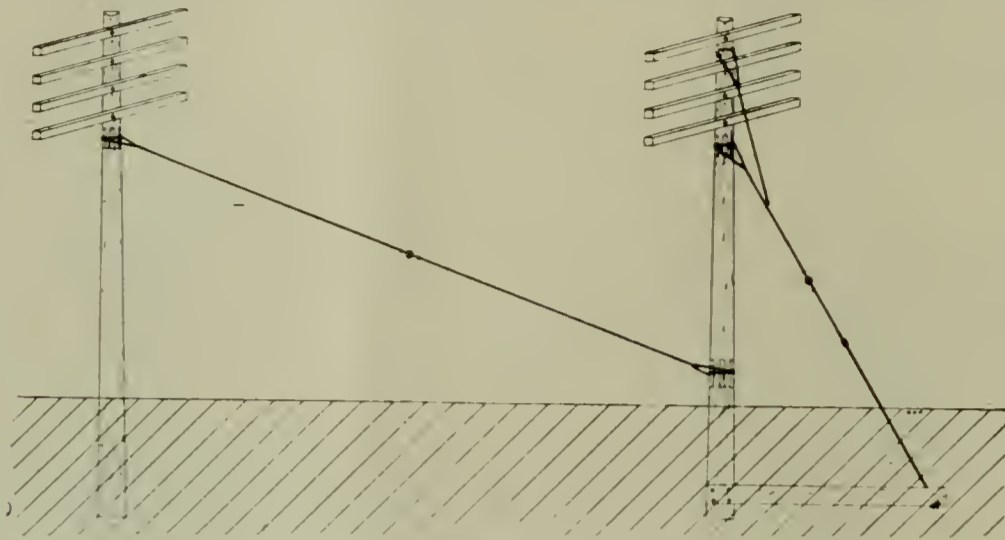

Fig. 7.

10.5 in. The length above the ground being 34 ft., the equivalent area of pole surface exposed is  $\frac{34 \times 10.5 \times 2}{12 \times 3} = 19.8$

sq. ft. The diameter of a No. 6 wire, with triple braid weatherproof insulation, is about .3 in. With 120-ft. spans, the area exposed per wire per span is  $\frac{120 \times 12 \times .3 \times 2}{144 \times 3} =$  two square feet.

As the force due to the action of the wind on the wires is exerted near the top of the pole, it is more effective than the forces acting along the pole

wind velocity with 30 wires would therefore be  $600 + 100 = 700$  lb. Or at a wind velocity of 75 miles and a force of 20 lb., the strain on the pole would be 1400 lb.

High velocities are attained for short intervals in nearly all parts of North America, and it is therefore advisable to provide protection for such sections of line as are exposed to the force of winds, if they carry more than two cross-arms full of circuits. This protection is sometimes difficult to provide when lines are on public highways. It may consist of struts on the side opposite that from which winds are expected, or guys secured

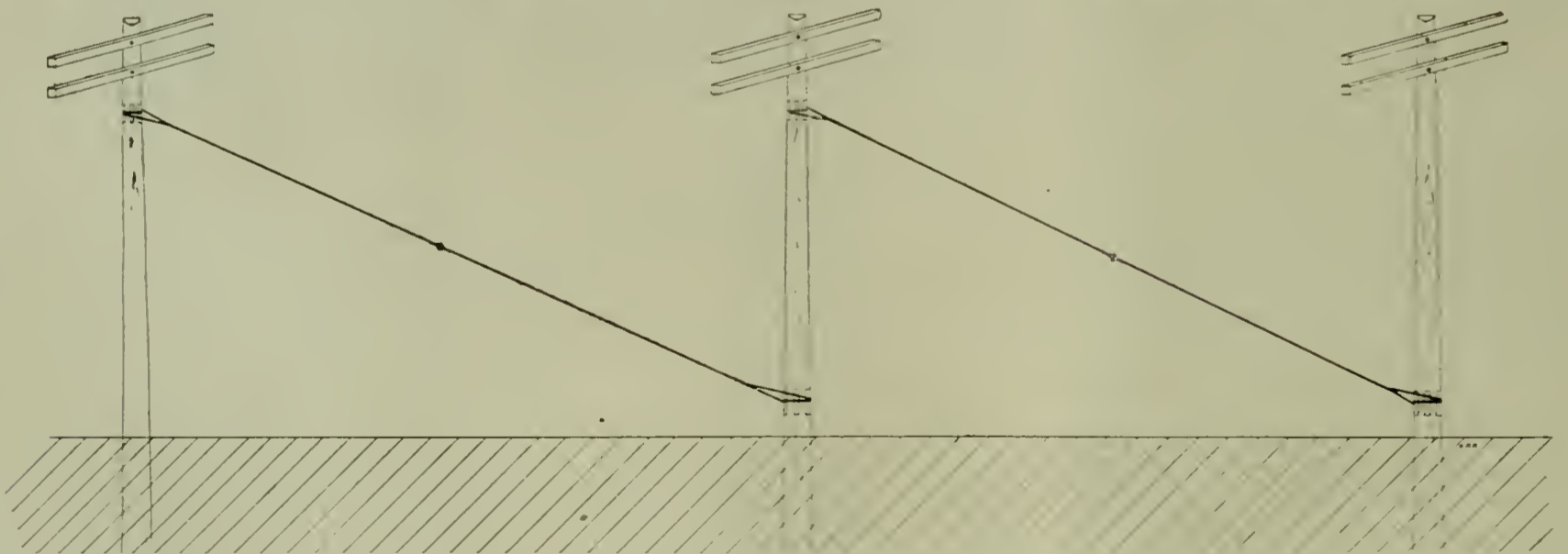

Fig. 8.

at various heights, which are due to the pressure of the wind on the pole.

Calculations made for a 40-ft. pole indicate that the strain imposed by the action of the wind on the pole itself is approximately equal to that caused by five weatherproof wires of No. 6 B. & S. gauge. At a velocity of 52 miles an hr. the wind pressure being about 10 lb. per

by anchors on the windward side. It is sufficient to reinforce every third pole, as the strain on the intermediate poles will be communicated to the reinforced poles when they are bent out of line by the wind.

Where the country is swampy more frequent supports may be necessary to keep the line from leaning over in the soft earth. This action is likely

Experience has proven that the following practice is conservative:

Size pole	Depth
30 .....	5½ ft.
35 .....	6 ft.
40 .....	6 ft.
45 .....	6½ ft.
50 .....	6½ ft.
55 .....	7 ft.
60 .....	7 ft.



The character of the soil and the diameter of the butt of the pole may effect these figures.

For instance, a Western cedar pole with a small butt, set in a sandy or swampy soil, will be much more likely to pull over than a Michigan cedar of the same height with a heavy butt, and rather more depth should be pro-

vided. There are various forms of patent anchors which may be installed by driving or boring into the soil, which have largely supplanted the Fig. 4 type of anchor in recent years.

Where the guy wire must cross a street, or for any other reason be kept above the ground, it is necessary to set a short pole as in Fig. 6. The

must be attached to the cross-arms, as well as the pole, in order to support the strain. This may be done by wrapping the guy wire around the arm, or by attaching to an eye-bolt, put through the arm. The latter method is preferable in most respects where primary lines are carried on the arms.

Small lines may be supported by a single galvanized steel wire of No. 6 B. W. G., but stranded cable is preferable for all lines of medium and heavy weight, owing to the greater facility with which it can be handled and secured at the ends. Such cable is made in sizes varying by  $\frac{1}{8}$  in. in diameter from  $\frac{1}{4}$  in. up. The ultimate breaking strength of steel wire being about 80,000 lb. per sq. in., the ultimate breaking strength of  $\frac{1}{4}$ -in. cable is 4000 lb.,  $\frac{3}{8}$ -in. 8000 lb.,  $\frac{1}{2}$ -in. 15,000 lb., and  $\frac{5}{8}$ -in. 25,000 lb. The

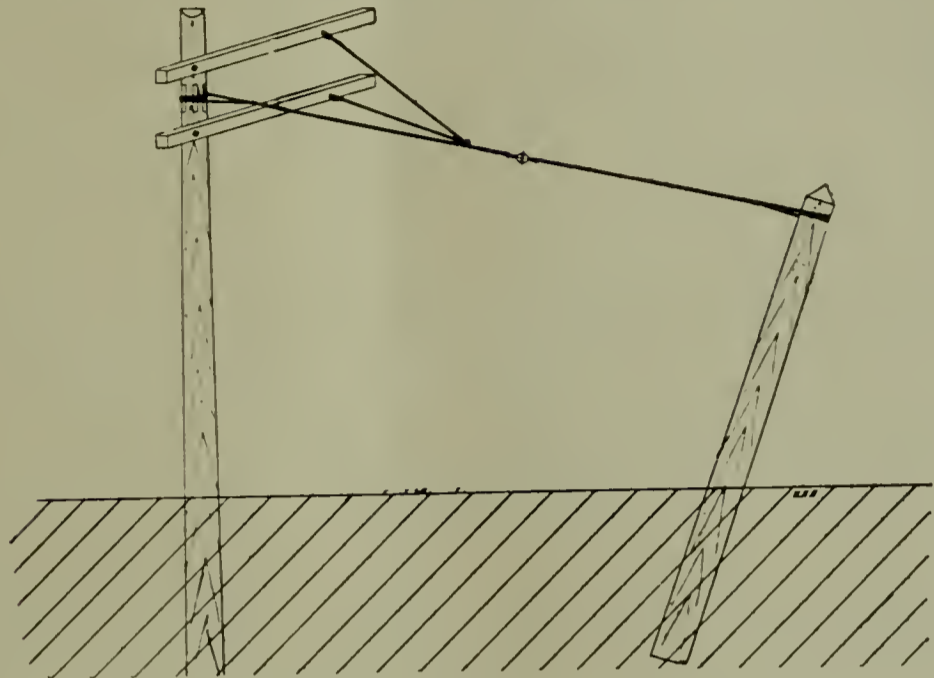

Fig. 9.

vided. In rocky soil, where boulders may be tamped about the pole, they need not be set so deep. The thoroughness with which tamping is done while the hole is being filled is also an important factor in the stability of the pole. Water should be used to settle the earth where the soil is dry and light.

height of the guy pole is fixed by the clearance required, and may be nearly as high as the main line. In case it is more than 20 ft. above ground it may be necessary to further reinforce the guy pole by an anchor. On a line carrying a considerable number of cross-arms, the guys should be attached to the pole at more than one point, as shown in Fig. 7, in order to avoid buckling of the pole under the strain. The form of anchor shown in Fig. 7 is suitable for the support of a heavy load at a point where cables are connected to overhead lines.

Where neither anchor or guy can be installed, the support can be provided in the form of head guys, as shown in Fig. 8. These are often advisable in any event as a reinforcement to the anchors or guy stubs placed at the end of the line. Head guys are also valuable in limiting the damage which might be done in a long line in case a pole failed at some point during a storm, or in case the wires all burn off at any point. Head guys placed alternately in opposite directions take the strain due to the release of the tension in the line if it breaks, and thus limit the damage done to the pole lying between the nearest opposite placed head guys. This form of protection should be provided on all lines exposed to high winds, in addition to guys placed laterally. It is also of value at crossings with other lines where there may be danger due to long spans.

In alley construction, where side-

arms are used as in Fig. 9, the guys pull on the pole due to the tension of the wires being calculated from their size, deflection and span lengths, the tension on the guy wire is found by dividing the total tension of all wires by the cosine of the angle made by the guy cable with the wires of the line. In other words, the tension on the guy cable in Fig. 6 is equal to the combined tension of all of the line wires multiplied by the length of the guy wire and divided by the horizontal distance from the pole to the point where the guy wire is attached to the anchor or stub.

It is evident that the tension on a guy cable installed as in Fig. 4 is much greater than one installed as in Fig. 6, assuming the same tension in the line wires in each case.

Having calculated the tension in



Fig. 12

any case, the size of guy cables should be such that the strain will not exceed one-fifth the ultimate breaking strength of the guy cable.

For instance, with a line carrying 18 wires as in Fig. 7, at a tension of 150 lb. each, supported by a guy cable



Fig. 10

At points where corners are turned and where a line comes to an end, the unbalanced strain due to the tension of the wires must be balanced by the use of guys or braces. In suburban work, a pole may sometimes be supported by being braced by a shorter pole, set at an angle of about 60 degrees, so that the short pole acts as a strut. This method requires space, which is not often available, and being unsightly, is not so well adapted to distribution work as is the use of wire guys secured to anchors of some sort.

The common forms of stubs and anchors used for such purposes are shown in Figs. 4 to 9, inclusive.

The small anchor of Fig. 4 is commonly used where there are no local conditions preventing its installation or maintenance. It may be made of short pieces of old poles or other timber, but it requires a considerable amount of excavation, which tends to make it expensive in some situations. The stub shown in Fig. 5 is less expensive to install and more generally



Fig. 11

40 ft. long, with the anchor attachment 30 feet back from the pole, what size of guy cable should be used? The total line wire tension is 2700 lb., and the guy cable tension is therefore

$$\frac{2700 \times 40}{30} = 3600 \text{ lb.} \quad \text{This is ap-}$$

proximately one-fifth the ultimate breaking strength of  $\frac{1}{2}$ -in. cable, which should therefore be used.

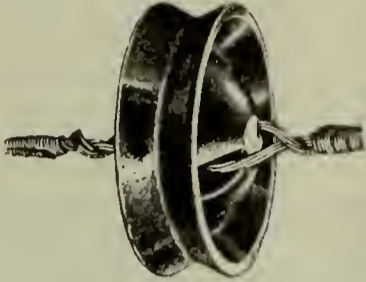

Fig. 13.

If the cable were 36 ft. long and the point of attachment were 12 ft. back from the pole, the tension on the guy

$$\text{wire would be } \frac{2700 \times 36}{12} = 8100 \text{ lb.}$$

This would require a  $\frac{7}{8}$ -in. cable. Such a cable, however, is cumbersome to handle and secure at the ends, and it would be preferable to use two cables, one of which might be a head guy from the top of the next to the last pole to the butt of the end pole. If each were of  $\frac{5}{8}$ -in. cable, the strain

could be adjusted between the two so as to reduce that on the end to the safe capacity of a  $\frac{5}{8}$ -in. cable. The head guy acting at a more favorable angle would naturally take more than half the strain.

Where primary wires are carried, it is important for the safety of linemen and the public that all guy wires and cables be broken into two or more sections by means of strain insulators. Two common forms of strain insulators are in use in America. That shown in Fig. 10 is designed to carry a strain of 3000 lb., while that in Fig. 11 is suited for 8000 lb. These insulators will temporarily protect the lower end of a guy cable from 2200-volt potential, but are not designed to be used with live circuits connected to one end. With low-potential lines up to 600 volts, the form shown in Fig. 12 is commonly connected directly to the circuit wires. This is desirable in heavy work in order to relieve the cross-arms and pins of the strain of supporting dead ended cables. In high-tension work, where special risk is present, the use of two strain insulators in guy cables is sometimes advisable as an additional precaution.

In recent years porcelain strain insulators have been developed which are suitable for use in dead ending primary feeders and transmission lines, without supporting the strain on an ordinary pin. One of these is shown in Fig. 13.

Various methods are followed in excavating holes for pole setting, different kinds of soil requiring different treatment. In sands or light loam, a long-handled shovel, with the digging portion bent at an angle, called a spoon, is used. A straight shovel is used in starting the hole and in loosening the dirt for the spoon. There are various forms of patented hand augurs, which are also useful in this kind of soil in loosening up the earth and forming a six-inch or eight-inch hole as a core around which the hole is widened to the desired diameter.

In clay, a digging bar must be used to loosen the solid mass before it can be lifted out with the spoon. The compactness of the mass makes it heavy as well as stiff, and the operation is necessarily slower than in sand.

In quicksand or marsh ground, special methods are resorted to. In quicksand a sand barrel is sunk in the hole as the excavation is made, to support the sides of the hole. This consists of a cylindrical metal sheathing about 24 in. in diameter, made in sections about 24 in. long, and divisible into halves, so that it can be drawn out of the hole after the pole has been put into it and taken off.

In marshy soil with a clay foundation, the water may sometimes be kept out by building an earthen dam about the hole after baling out the excess, in which case the sand barrel is not used.

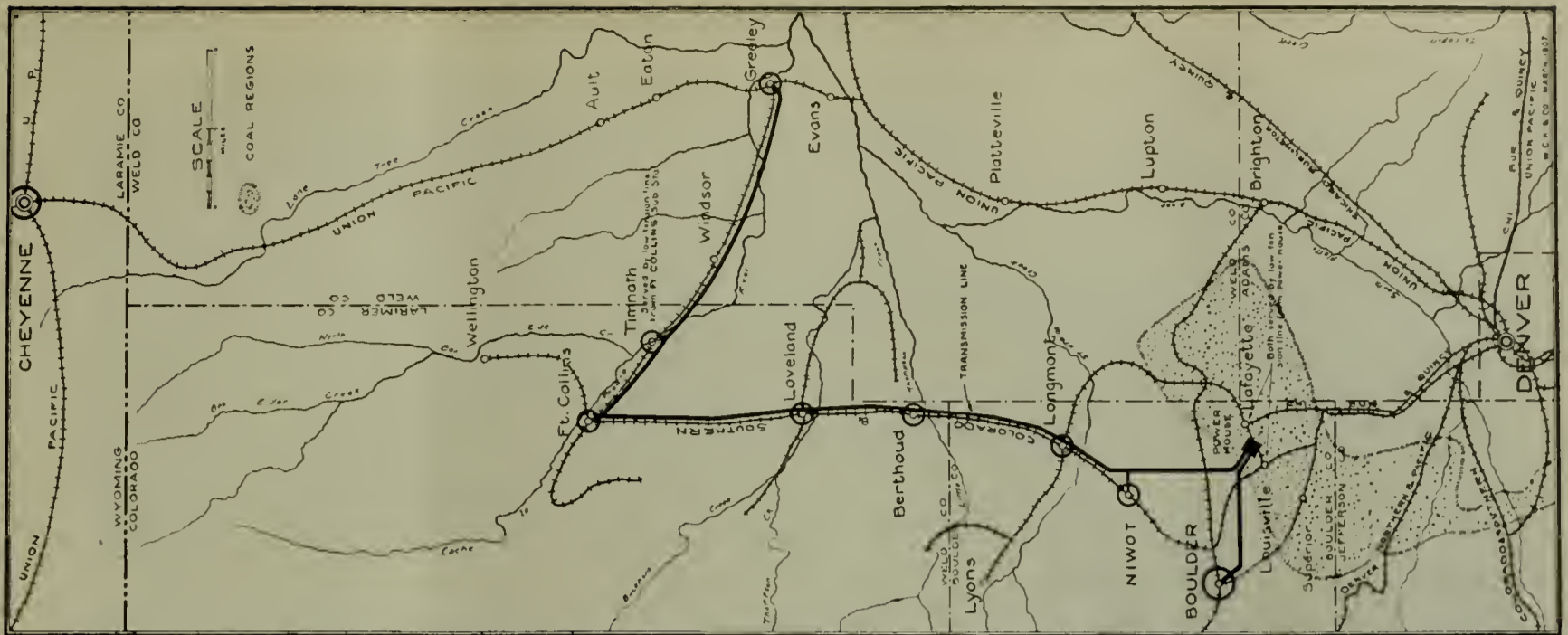

Fig. 1.—MAP SHOWING LOCATION OF MAIN POWER STATION AND DISTRIBUTION SYSTEM.

## The Power Development of the Northern Colorado Power Company

OF the many projects which have been conceived in the various parts of the country for producing electric power directly at the coal mine and transmitting current to the centers of distribution, the Northern Colorado Power Company's project is one of the first to be actually developed and put into successful operation.

From the map, Fig. 1, showing the territory directly north of Denver and including a small portion of Wyoming, it will be noted that the development of the Northern Colorado Power Company consists of a power generating station located over the coal measures in the vicinity of Louisville, with transmission lines to the various important towns north and northwest of Denver, at which towns substations receive and distribute the current to the various consumers.



Fig. 2. POWER STATION, BOILER-ROOM SIDE.



Fig. 3 POWER STATION, RESERVOIR SIDE, SHOWING JET CONDENSERS.

Certain large customers are served directly from the power station or from the transmission lines. The Company also operates as a separate enterprise the local electric light, heat and gas plants in Cheyenne, Wyoming.

The coal found in this part of Colorado is a lignite, which disintegrates rapidly when exposed to the weather, and after such exposure for two or three weeks is burned with difficulty. There is, therefore, unusual advantage to be gained by using the coal promptly after it is mined, especially the lower grades. There are a number of mines in the vicinity of Louisville, and slack from these mines can be purchased for the power plant at from seventy-five to ninety cents per ton. The calorific value of this coal averages about 10,800 B. T. U. per lb.

The extensive system of irrigation canals and ditches which has been con-

structed in this section of Colorado has been utilized as the source of supply for providing water for the operation of the power plant condensing. Provision has been made for impound-

floors and roof of concrete, walls of brick, and trim of cement blocks. The only steel framing is in the floors and roofs and in the supports of the coal bunker and the front ends of the

machines serve the general power distributing system and the two smaller units furnish current for the single phase equipment of the Denver & Interurban Railroad. The generators are of the Westinghouse enclosed type, the circulation of air through the windings of the machines being provided by impellers located on the armature shafts. These generators are driven by Westinghouse-Parsons single-flow turbines, operating at 1200 and 1500 rev. per min. Boilers of the Franklin water tube type are used, having a total rated capacity of 4110 boiler horse power. These boilers are equipped with Roney mechanical stokers of somewhat special design to handle the kind of fuel available.

Draft is produced by means of two three-quarter housed fans having wheels 14 ft. in diameter, this induced draft system with its short stack being particularly adapted to this section of country where very high winds occur at times. Green fuel economizers are installed; also a coal-handling equipment using the belt type of conveyor for handling coal to the bunker. The capacity of the coal bunker over the boilers is 280 tons, which, while it may appear relatively small, is accounted for by the rapid



Fig. 4.  
TURBINE ROOM, SHOWING SWITCHBOARD IN REAR.

ing a sufficient quantity of water for this purpose, the reservoir having for its source of supply one of the irrigating ditches in the immediate vicinity. An artesian well on the company's property has been provided to supple-

boilers. Good pressed brick was obtained in the neighborhood at a low price and made possible a simple but effective architectural treatment at moderate cost.

The generator equipment is of



Fig. 5.  
AISLE BETWEEN TRANSFORMERS AND LIGHTNING ARRESTERS.



Fig. 6.  
AISLE BETWEEN SWITCH STRUCTURE AND TRANSFORMERS.

ment the supply obtained from this reservoir.

#### POWER STATION.

The building is of substantial fire-proof construction, with foundations,

6000-kw. capacity and consists of two 2000 kw., 60 cycle, 3 phase, 13,000 volt turbo-generators, and two 1000 kw., 25 cycle, single phase, 11,000 volt turbo-generators. The two larger

deterioration and disintegration of the lignite coal available and also to its liability to spontaneous combustion when stored in quantity.

The power-house has a standard



Fig. 7.  
OIL SWITCHES AND BUS STRUCTURE.

gauge switch track from the Colorado & Southern Railroad and a narrow gauge track to the Power Company's mine and also to the mine of the Electric Coal Company, which is near by.

#### TRANSMISSION SYSTEM.

Power is distributed from this station at three voltages. The towns of Louisville, Lafayette and Superior, which are within a radius of  $1\frac{1}{2}$  miles are served with power at the regular distribution voltage of 2400. Boulder, which is 9.8 miles from the power-house, is served by a transmission line operated at 13,000 volts, and the other towns north from the power station are served by a 65.7 mile transmission line operating at 40,000 volts. All this power for general distribution is generated at 13,000 volts and transformed to the other voltages by means



Fig. 8.  
BOILER ROOM, SHOWING STOKERS AND COAL CHUTES.



Fig. 9.  
MAIN TRANSMISSION LINES LEAVING POWER HOUSE.

of transformers located in the power station.

Fig. 9 illustrates the two trunk lines (13,000 and 40,000 volts) as they leave the power station. These lines are constructed on cedar poles, no poles less than 8 in. in diameter at the top being used. The entire construction is rugged in character. The details of the pole top for the 40,000-volt line are shown in Fig. 10.

Porcelain insulator (R. Thomas & Sons) on iron pins are used. The cross arm pins are of the "Smith Grip" type. The ridge pin is a special design forged from wrought-iron pipe. The spacing of the wires on the 40,000-volt line is 48 in. and on the 13,000-volt line 26 in. The transmission lines are located in part on private right of way, in part on the public highways and in part on the right of way of the

Colorado & Southern Railroad. Where they cross foreign wires, suitable means have been provided for preventing contact between the transmission wires and the foreign wires in case of breakage of either. The Company has its own telephone lines which are placed on the transmission poles.

#### SUBSTATIONS.

Two types of substations were used, differing in characteristics only to the extent necessary for the difference in voltage of the transmission lines entering them. The Boulder substation, which receives current at 13,000 volts, is illustrated in Figs. 11 and 12. The Longmont substation receives current at 40,000 volts. This latter station is typical of the five remaining stations, which are all operated at 40,000 volts.

The 13,000-volt substation is sufficient in size for 1200 kw. of transformers and has a cubical contents of



Fig. 10.  
DETAILS OF POLE TOP, 44,000 VOLTS.

13,900 cu. ft., or 11.6 cu. ft. per kw. The 40,000-volt station, sufficient in size for 600 kw. of transformers, has a cubical contents of 17,900 cu. ft., or 29.8 cu. ft. per kw. The larger space necessary in the higher voltage stations is due to the clearance required between wires and to the free room necessary for automatic circuit-breakers and lightning protection devices.

Each substation is provided with a suitable equipment of potential regulators, circuit-breakers, indicating and recording meters and lightning arresters.

#### USE OF POWER.

From each substation electric current is distributed at 2400 volts for miscellaneous lighting and power purposes. At Boulder and Fort Collins direct-current power is also furnished for the operation of street railways. A number of mills and industrial enterprises are served and the pole lines are designed for the addition of low-voltage feeders between substations from which power may be sold to out-of-town users.

Another considerable market for power which it is expected to develop is in furnishing current for pumping in connection with irrigation, such pumping plants being served from the low-voltage circuits which are to be provided between substations.

#### SINGLE-PHASE SERVICE.

As previously stated, the two 1000-kw. units of the power-house are for the service of the Denver & Interurban Railroad, and their output is used to operate the electric trains between Denver and Boulder. Fig. 13 illustrates the lines of this railroad, the location of the power-house with reference thereto, and the

feeder lines from the power station to the junction point. Power is delivered to the trolley wires at 11,000 volts and 11,000 volt single phase car equipments are used, 8 motor cars and 4 trailers being provided for the initial service. The overhead conductor is designed with a view to considerable increase in the service.

#### RESERVOIR AND DAM.

Before the construction of the power-house a reservoir existed at this point, which had a capacity of about 10,000,000 cu. ft. and covered an area of about 29 acres. To insure an adequate water supply, a new earthen dam was built, raising the level of the reservoir 10 ft. and increasing the area of the reservoir when full to 56 acres and the capacity to 28,000,000 cu. ft.

The new dam was built entirely of

earth with a puddled core. The total length is approximately 2700 ft., and the greatest height approximately 30 ft.; width on top 10 ft.; slope of inner face 3 to 1; slope of outer face 2 to 1. Sixty thousand yards of earth were placed in the new dam. All surface soil, roots and vegetable matter were removed from the base of the dam and from the surface of the old dam before the new work was commenced. The character of the subsoil was carefully examined by means of borings and test pits and was found to consist of sandy clay, quite impervious to water and generally free from sand pockets. It was therefore unnecessary to excavate below the surface soil for foundations. The sandy clay material was found to be suitable for dam construction without admixture, if thoroughly compacted, and sufficient



Fig. 11.  
BOULDER SUBSTATION, 13,000 VOLTS.



Fig. 12.  
INTERIOR OF BOULDER SUBSTATION.

quantities were obtained from borrow pits within the flooded area. In removing the material from the bor-

stones. For this purpose, 3269 cu. yd. of stone were required.

The work was done with great care

and the result is a structure of very permanent character.

OPERATION.

Previous to the organization of the Northern Colorado Power Company the various towns were served with electric power from local steam plants. On October 1, 1907, the transfer of the load to the new Lafayette station was commenced, and since December 24, 1907, the new plant has been giving admirable service to the entire system. The old plants are shut down and are being dismantled.

The description of this power project and the illustrations of it were furnished by Westinghouse Church Kerr & Company. As engineers and constructors for the Northern Colorado Power Company, they made the preliminary investigations, developed all the plans, designs and detail requirements for the new power equipment, and performed at first hand all the construction work, including power station, transmission lines, substations and dam for the reservoir. The engineers also acted for the Power Company in the design and construction of the catenary trolley work over the tracks of the Denver & Interurban Railroad, this electrification work having been done by the Power Company for the Railroad Company.

All this work was performed by the organization of Westinghouse Church Kerr & Company under its general method of engineering rendering, with Oliver S. Lyford, Jr., M. Am. Inst. E. E., as administrator, William A. McClurg, Assoc. M. Am. Inst. E. E., as engineer in charge, and J. W. Baugher, as superintendent.

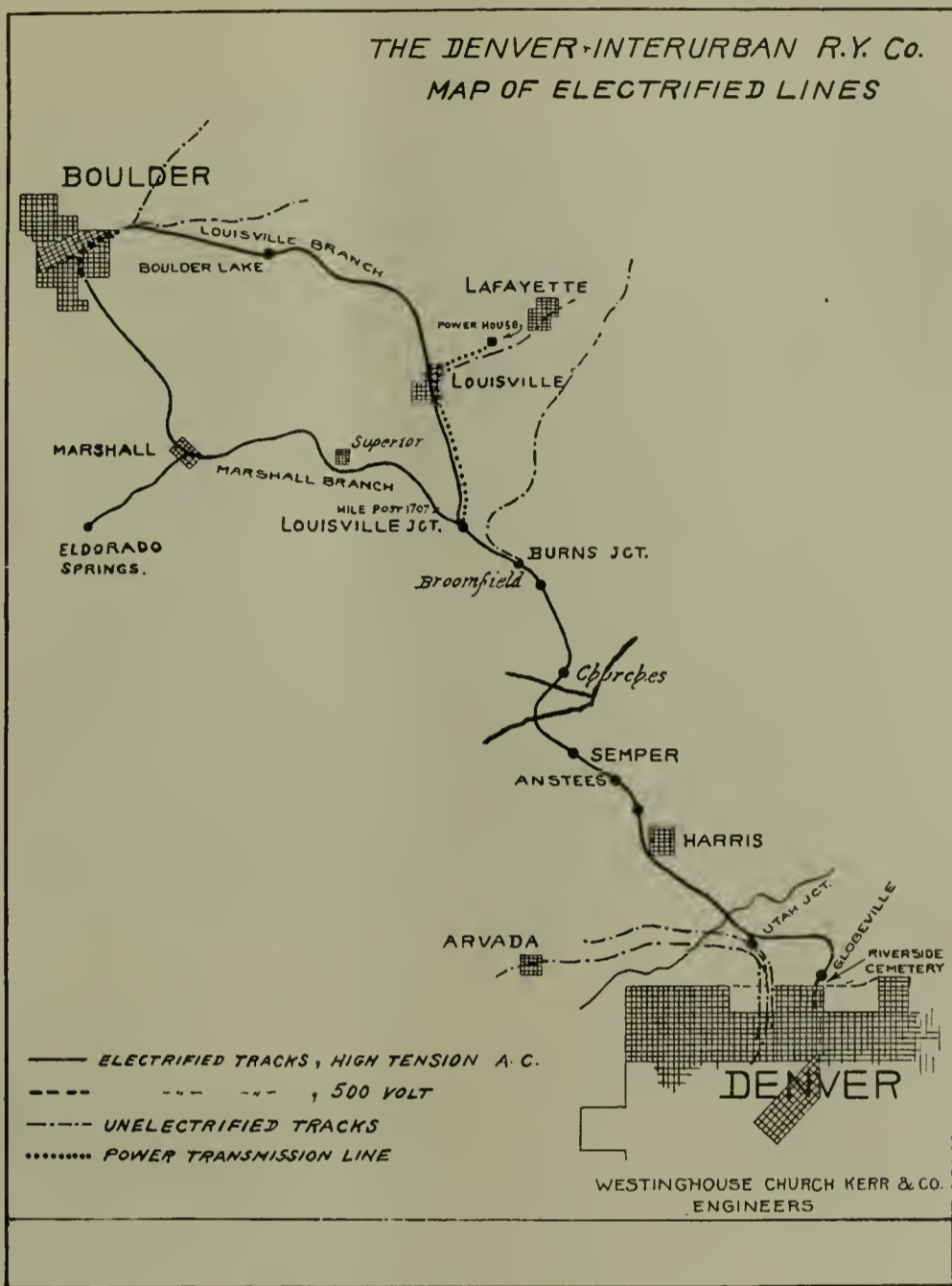

Fig. 13.

MAP OF DENVER AND INTERURBAN LINE BETWEEN DENVER AND BOULDER.

row pits care was exercised to retain a minimum depth of at least 5 ft. of impervious material at all points.

To insure that it was compacted, a puddled core for the dam was built 6 ft. wide at the top with side slopes  $\frac{1}{10}$  ft. horizontal to 1 ft. vertical. This puddled core was composed of the most impervious material found on the site. The drains and irrigating pipes through the core are of cast-iron and are provided with head walls and collars of concrete. A suitable spillway, thoroughly protected against washing by a concrete head wall and lining, was provided for the overflow. Owing to the heavy winds in this locality the wave action is considerable (Fig. 14.) To protect the dam against damage by this action, the inner slope was covered to the depth of 18 in. with a heavy rip-rap of loose

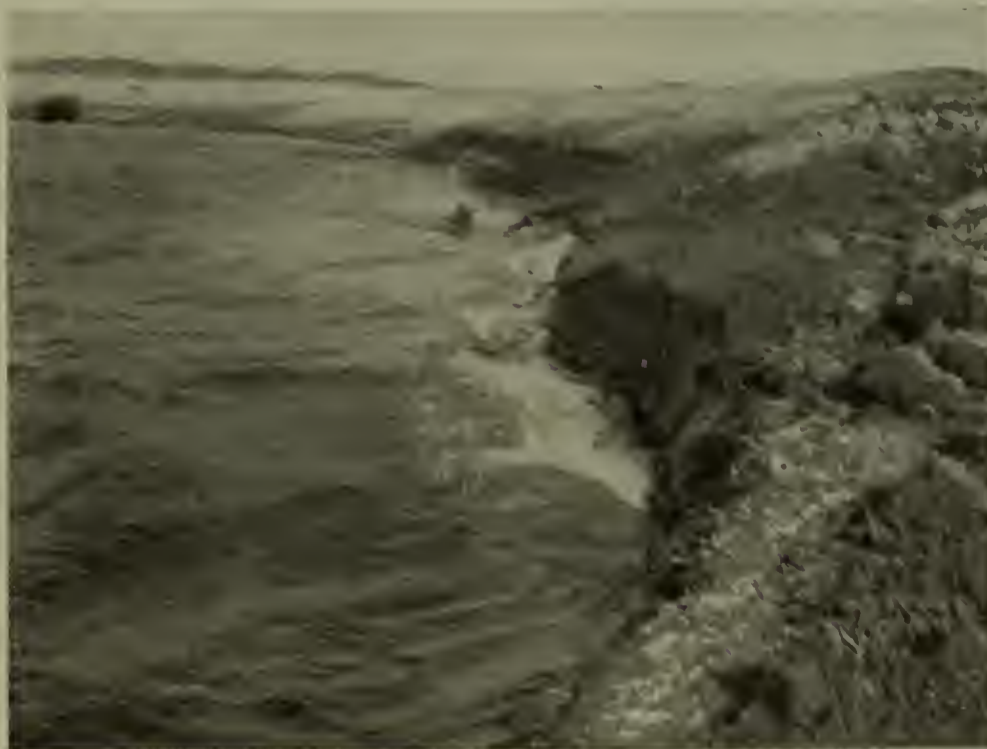

Fig. 14.

WAVE ACTION, DUE TO HIGH WINDS.

# Series Incandescent Systems with Tungsten Lamps.

By P. D. WAGONER\*

IN the early history of series incandescent lighting, the life of the units that were used was approximately 150 hours, with an efficiency of four watts per candle-power. Improved manufacture of these lamps brought the figures to 3.5 watts per candle-power. This efficiency was obtained about 1885. The life of the 3.5-watt lamps at that time was from 200 to 300 hours, but, in the later development, reached an average life of 600 to 1000 hours. For many years the latter figures remained unchanged, and the advocates of series incandescent street lighting were compelled to face the obstacle of comparatively low efficiency. Only in recent years has the development of the Gem high-efficiency unit at 2.7 watts per candle and the tungsten lamp at 1.25 watts per candle placed the series incandescent system on a basis to compete effectively with other systems of street illumination.

Indications of most satisfactory tungsten life have been obtained in actual practice; for example, in one installation of 172 lamps an average life per lamp of 1350 hours has been obtained. A test conducted on 18 lamps of this type resulted in 12 lamps running over 2000 hours without breakage or perceptible decrease in efficiency. It, therefore, would seem reasonable to expect an average life of 1500 hours at 1.25 watts per candle. The initial efficiency seems to be maintained pretty generally throughout the life of the lamps, while with the carbon lamp it decreases from 25 to 50 per cent.

Considered as a mere source of light, the series arc lamp is of higher efficiency than the tungsten lamp; but this fact does not necessarily mean higher illumination efficiency. As illumination varies inversely as the square of the distance from the source of light, and since, therefore, the intensity of illumination falls off very rapidly as the distance from the source increases, there are many cases in which a more uniform and, therefore, more satisfactory illumination can be obtained by means of incandescent lamps placed at closer intervals than by arcs of greater total light flux placed at longer intervals.

The arc lamp is well adapted to streets requiring a sufficiently high intensity of illumination to permit of their being spaced at comparatively short intervals.

The incandescent lamp is best adapted to streets requiring a lower intensity, where arc lamps, to compete economically, would have to be placed so far apart that the intervening space would be practically unlighted, though an unnecessary intensity would be provided in the immediate vicinity of the lamps.

In the case of an arc lamp hung in the middle of a 30-foot suburban road, its rays of maximum intensity being (in case of the magnetite or luminous arc) about 10 degrees below the horizontal, a large portion of the light will be wasted beyond the fences in the surrounding fields, where it is of no value whatever.

The lighting of intermediate districts, between the principal business districts and the outlying districts, depends upon local conditions. In the residential section of cities having wide streets and long blocks, it may be found economical to place arc lamps at intersections of the streets and light the intervening spaces by incandescent lamps.

In some localities, where electricity or gas are not readily available, the oil lamp is still to be found, but this type of street illuminant may be considered a relic of the past and is almost extinct in towns even of moderate population.

Among the gas flame lamps now in use may be enumerated the acetylene, the open-flame naphtha, the gasoline gas, the open-flame gas, the mantle naphtha and the mantle gas. The series Nernst lamp has been used to some extent for the purpose of street lighting, but has made little progress in this field. The tungsten lamp should place series incandescent lighting beyond question of competition from these types of street illuminants.

Series tungsten lamps are capable of test and definite rating, and when the circuits on which they are operating are supplied with proper regulating apparatus practically uniform candle-power is obtained throughout the life of the unit. On the other hand, the welsbach gas mantle cannot be tested previous to installation, on account of fragility. It is subject to considerable depreciation in candle-power during the first few hours of burning, and the candle-power is subject to wide variations, depending upon the condition and adjustment of the burner, partial breaking of the mantle, and weather conditions. The decrease in candle-power is par-

tially due to the actual diminution of radiating surface of the mantle from surface disintegration. In about 300 hours the efficiency may fall off to nearly one-third of its initial value, after which the decrease is less rapid during the remainder of the life of the mantle

## The New Model Roney Stoker

THE coal is fed into a hopper extending across the boiler front, usually by gravity from an overhead bin. From this hopper the fuel is automatically supplied to the furnace by a reciprocating pusher operated from the rock shaft by an eccentric. The fuel descends through the throat of the arch on to the upper grate bars, where it is subjected to an intense heat radiated from the incandescent fire-brick arch spanning the upper portion of the furnace. This entirely cokes the fuel and drives off all the volatile gases, leaving the coke, or fixed carbon, which is then gradually worked down the inclined surface by the rocking motion of the grate bars, im-



NEW TYPE GRATE BAR.

parted to them from the eccentric on the rock shaft.

The oscillation of the grate bars not only works the fuel slowly down the furnace, but also keeps it constantly agitated, this preventing, to a large extent, the formation of clinker, and bringing the fuel into intimate contact with the incoming air. After the solid combustibles have been totally consumed, the remaining ash is discharged on to the dumping grate at the bottom of the furnace.

One of the most important features of the New Model Roney Stoker is the sectional grate bar, or fire top, illustrated herewith. For the upper four grates a non-sifting type top is used, provided with abutting horizontal ledges to prevent the fine fuel from sifting through the bars and at the same time permit a free entrance of

\*Address before the National Electric Light Ass'n, 1908



the air. As only the thin edge of the fire top is exposed to the direct heat of the fire, while both sides and the bottom edge are cooled by the incoming air, it is evident that these tops are well protected from overheating, thus insuring long life. As previously

used, the platform carrying the lamps can be readily lowered without taking the fixture apart. This adjustable feature makes the fixture universal for all types of incandescent lamps.

The illustration shows the standard 26-in. cluster. The diffuser is made

diffuser is recommended, and for mill and factory work the 39-in. gives more satisfactory results as regards distribution and diffusion.

It has been found from experience that the 39-in. tungsten economy diffusing cluster gives excellent results for mill lighting when equipped with three 100-watt tungsten lamps. This permits, for the same energy, somewhat closer spacing than arc lamps.

The shade is made of clear glass frosted on the inside, and as may be seen from the illustration, is curved to take the same general shape of the lamps. Placing the frosting on the inside of the shade gives a lower intrinsic brilliancy than is obtained by the same grade of frosting placed on the lamps, and does not reduce the life of the lamps. The six-lobed shade is standard for all lamp combinations, and the curvature of the shade minimizes the spotted effect so apparent when part of the lamps are extinguished in a fixture having a spherical globe.

By using various combinations of 40, 60 and 100 watt lamps, the cluster can be made to operate at 120, 180, 240, 300, 360, 420 and 480 watts.



NEW MODEL RONEY STOKER.

mentioned, for each square foot exposed to the fire, 7.4 sq. ft. of surface is cooled by the air, giving 7.4 times the cooling effect of the flat-top grate bar.

As will be seen from the illustration, the grate proper consists of a number of thin plates set on edge in V-grooves. These hook over a trussed web and are held in place by a key-rod slipped in from the end. They are, therefore, easily removed. The webs have conical bearing surfaces at the end, which makes them self-centering in the side bearers and prevents any uneven wear. By lifting the webs out of the bearers and removing the key-rods, the tops may be redistributed if desired, so as to equalize the wear in various parts of the furnace.

#### A New Tungsten Diffusing Cluster

To fill the demand for a large lighting unit of approximately the same power as the enclosed arc lamp, the General Electric Company has perfected the tungsten economy diffusing cluster. This unit provides, in addition, a light of variable intensity, with a wide range of wattage adjustment without mechanical change.

The diffuser is designed primarily to carry six tungsten lamps suspended in a vertical position. Very good results, however, can be obtained by the use of either tantalum or carbon filament lamps. When the latter are

of steel, coated with white porcelain enamel on the under side and black on the top. The supporting reflector is made of brass with a nickel finish, and carries springs to compensate for expansion or variation in the size of the globes. The casing is finished in streaked oxidized copper. When desired, a streaked oxidized silver or verd-antique finish can be supplied.



The 39-in. or mill type diffuser is identically the same as the 26-in., except that the diffuser is larger, and instead of being finished in porcelain enamel is coated with white zinc enamel. For store lighting the 26-in.

#### Northern "C" Type Electric Chain Block

The Northern Type C electric hoist is designed to supplant the ordinary hand chain block suspended by a single hook. It is of the same general design as the hand chain blocks, excepting that it is driven by a crane motor with a standard crane controller with ample resistance. It can be operated at fast or slow speed, as desired, and it is possible to operate it at a speed 10 times faster than by



NORTHERN "C" TYPE ELECTRIC CHAIN BLOCK.

hand power. A hoist of a given capacity is of about double the size and strength that it would be if operated by hand power. This larger safety factor is used on account of the more severe service under electric power.

As compared with the ordinary drum-hoist, it has the advantage of suspension by a single hook, and tipping or getting out of line will not get the sprocket chain out of the

sprocket groove, as would be the case with a wire rope on a drum. The hoist can also be swung off sidewise without meeting this difficulty.

Spur gears cut from the solid steel blank are used throughout, avoiding the worm gearing, beveled gears or sun and planet combination. The use of straight spur gearing on this hoist materially increases its life and decreases the amount of repairs. The principal gears are accessibly enclosed for oil bath. Motors of any standard make can be used. Sizes range from one to six tons. The hoist is manufactured by the Northern Engineering Works, Detroit, Mich.

### Power Station Lighting

MADISON, Wis.,  
August 20, 1908.

*The Editor:*

Kindly permit me to make a few remarks as an addition to my article on "Power Station Lighting" in the August issue of your paper, as I note in the editorial on this article I have not succeeded in presenting it in a sufficiently clear language, and I would like, therefore, to give a further explanation.

I did not intend to advocate the use of the direct current from a storage battery for general station lighting, as this would obviously require a very large battery and result in perhaps the most expensive lighting scheme that could be designed, and your statement that most engineers would not entertain a proposition like that is certainly very true. My idea, however, was to make use of the charging set (for the emergency battery) to supply the current for the general illumination, leaving the small battery fully charged all the time, ready to jump automatically into service in case of a sudden breakdown of the main source of supply for lighting. The battery will have to supply only a limited number of lamps at prominent places in the station, just to give enough light to be able to keep up service. The charging set in this case must, of course, be larger than the battery alone would require, in order to carry the total lighting load.

The article had particular reference to large-size power stations, and especially hydroelectric plants, where no emergency connection to an outside source of supply can be had. Stations of this kind will always have a small storage battery for emergency lighting and a corresponding charging set. The advantage of a lighting scheme, as proposed in the article, lies in the fact that no additional machines, switchboards and connections are required, but simply to make the charging set larger than would be needed for the battery alone. This in

turn simplifies the station wiring very much, as will be seen immediately when sketching out the respective station lighting for alternating-current distribution.

The double-pole double-throw circuit-breaker with no voltage release was not intended to be offered by itself as a new suggestion, and its being available on the market is rather welcomed, as it eliminates the only objectionable feature of requiring special apparatus.

Another advantage of the proposed scheme may yet be mentioned, and which has not been cited in the article, *i. e.*, the possibility of supplying the crane motors, which generally use direct current, from the charging set instead of from the spare exciter, by simply providing a by-pass switch across the double-pole double-throw switch on the main lighting board. This will bring the charging set in direct connection with the exciter board, or more properly, with that particular panel on the exciter board which controls the feeders for the cranes and the connecting cables to the main lighting board. The starting up of the large spare exciter whenever the crane is needed is hereby avoided, which will simplify the station operation considerably, especially so in case where the arc lamps have regularly to be trimmed from the crane.

Yours very truly,  
MAX H. COLLBOHM.

### More Printing Press Data

The Miehle Press is one of the best-known cylinder presses on the market. The following information has been obtained for the benefit of those who have to apply motors to them.

The motors are always equipped for variable speed. This may be of the armature resistance kind if the buyer desires to keep down first cost, or of the field resistance type if economy of current consumption is preferred. There are a number of standard controllers of either type which may be purchased on the market. The controllers are always located at the most convenient point for the operator, as he stands on the feeding platform.

	Rev. per Impression.	R. P. M. for General Work.		Press Pulley.	H. P. of Motor.
		Min.	Max.		
00000	12	195	315	24	5
0000	12	195	315	24	5
00	12	195	315	18	4
1	12	215	345	18	3½
2	12	230	370	18	3
3	12	238	382	18	3
4	12	255	410	16	2½
5	7	160	256	16	2

Cast welded joints on 7-in. rail cost \$3.50 each.

### Sale of Small Curtis Turbines

The increasing use of small Curtis steam turbines is strikingly shown by an inspection of a partial list of turbines under 500-kw. capacity, which up to the present time have been installed by the General Electric Company or are under construction.

Of the 570 odd turbines listed, representing a total capacity of about 37,000 kw., 7 per cent. are for the export trade. The remainder are intended for domestic service in central stations, marine work, laboratories of educational institutions, power and lighting plants for hotels and office buildings, laundries, mines, printing establishments and in every branch of manufacturing.

### Trade Notes

The Great Northern Railway has placed orders with the General Electric Co. for four 100-ton electric locomotives for handling its trains through the Cascade Tunnel in Washington. Each locomotive will be capable of hauling a 1000-ton train at a speed of 15 miles an hour on a two per cent. grade.

The installation is the first to employ three-phase motors for railway service in this country. The Great Northern locomotives will be much larger and more powerful than any used on European three-phase roads.

According to the *Mexican Herald*, the Compania Minera Las Dos Estrellas has ordered machinery for the electrification of a part of its present steam road. A 450-h.p. motor-generator set will be located centrally with regard to the part to be electrified, taking current from the Mexican Light and Power Co. The first installation will consist of a 60,000-lb. electric locomotive for hauling large self-dumping freight cars. The company already has in operation six small electric locomotives working about the mine and yards, through the use of which it has reduced the cost of haulage one-half. The Westinghouse Company will furnish the new equipment.

### Squibs

It takes a quart of water per kilowatt lost per minute to keep oil-filled water-cooled transformers cool, when the cooling water enters at 25 degrees cent.

7000 thermite joints on 95-lb. T-rail cost \$4.50 each. Street opening cost \$1.00 each, and joint proper \$3.50 each.

The conductivity of track rails is generally figured as  $\frac{1}{10}$  of copper equivalent. Third rail is figured as  $\frac{1}{8}$  of copper.

### Questions and Answers.

Question.—Every little while I see something in the electrical papers about 60-cycle 550-volt rotary converters, which seems to infer that these are difficult machines to build. We have rotary converters in our powerhouse, a 25-cycle system. I see no reason why they should not be built for any condition, when other kinds of apparatus can be so easily made for difficult voltages, cycles and phases.

Answer.—As the power for a rotary converter is obtained from an alternating-current source, the number of poles in the machine must be dependent on the frequency for a given speed. If, for instance, a 600 rev. per min. rotary converter were desired, this would be a 12-pole 60-cycle, or a six-pole 30-cycle machine. Both machines would be about the same size for the same kilowatt output, but in the 12-pole one the spacing between collecting bushes would be half of the spacing in the six-pole. In a 550-volt machine, therefore, there would be twice as much voltage between any two commutator bars as in the lower frequency machine.

This in itself would cause no serious trouble if the direct-current load were fairly constant. But as the machine is nearly always applied to a railway system, the operating conditions cause a continual rapid fluctuation in load of wide limits. It is these fluctuations which momentarily, at times, cause the voltage across the commutator bars to jump one or two bars, and then the whole gap from brush to brush. It is this "bucking over" which causes so much trouble.

In low-frequency machines the few poles do not force such extreme conditions, and, therefore, the 25- and 30-cycle rotary converters seldom give trouble.

Question.—I have a 10-h.p., 220-volt, 60-cycle, three-phase induction motor. It is marked 27 amperes per terminal. Does this mean that the motor takes 81 amperes total at full load? If I were to test the motor with voltmeter and ammeter to find out how many horse power I am using, how should I go about it?

Answer.—The motor does not take 81 amperes at full load. Direct-current motor workers are accustomed to gauge the relative horse power of motors by the ampere input, but this is not possible with alternating-current machines.

In the case you mention, an ammeter in each leg would read 27 am-

peres. This would be due to the fact that alternating-current meters are made to read only the peaks of the ampere curves. If it were not for this the needle would be jumping from 0 to 27 at the rate of 7200 times a minute. No one could use such an instrument. The energy at any one instant is 10 by 746 watts plus enough to cover losses. The relation of this sum to the amperes per terminal is expressed by the formula (for three phase)—

$$\text{Amps. per term.} = 58 \frac{\text{Watts} \times \text{Efficiency of Motor}}{\text{Voltage} \times \text{Power factor}}$$

In your case this would become

$$27 = .58 \frac{W \times E}{220 \times PE} = W = \frac{27 \times 220 \times PF}{.58 \times E}$$

You will therefore see that the efficiency and power-factor would have to be obtained from the makers. If an indicating wattmeter and a power-factor meter were available, then E could be worked out. But the watts input would be the important factor to obtain. By deducting, say, 15 per cent. (for losses), and dividing the remainder by 746, the result would be very close to the horse-power rating.

You will observe that it is not directly possible to obtain the result you desire. This is also true of a direct-current motor. In either case the watts input may be obtained, but without knowing the efficiency the horse-power rating must only be an intelligent guess, based upon an assumed efficiency. The only satisfactory way to test any motor is by using a prony brake and plotting out curves of torque, amperes, voltage, heating and other factors.

When it is desired to approximate results the formula is often resorted to with assumed efficiencies and a power-factor of about 88 per cent. for 10-h.p. motors.

### Legal Notes.

#### TERMINATION OF FRANCHISE.

Where a contract between a village and individual, granting to him the privilege of using the streets in connection with the operation of a lighting plant, contemplated the extension of the franchise beyond the period specified in the contract, unless the village elected to purchase the appliances, and the contractor and his successors continued to use the franchise from year to year and improved the plant, all of which was done with the acquiescence of the village authorities, but without a formal renewal of the contract, as therein provided, the village could not make the omission to renew the contract a ground for impeaching its validity, or claim that the

contractor's successors were in the streets unlawfully. *Wakefield v. Village of Theresa*. Supreme Court of New York. 109 N. Y. Supp. 414.

#### CONDUCTOR'S CHOICE OF NEGLIGENT METHOD.

Where an electric car ran through a flock of chickens, and the conductor leaned out the side door to see the result and was struck by a pole and killed, when he might, with safety, have looked back through the empty car, he was guilty of negligence precluding a recovery against the master, since where there are two ways of performing an act, one safe and the other negligent, and the servant, without coercion, chooses the negligent one, there can be no recovery for a resulting injury. *Kath v. East St. Louis & Suburban Ry. Co.* Supreme Court of Illinois. 83 Northeastern 533.

#### LIGHTING CORPORATIONS.

An electric light company supplied an individual with electricity for lighting his residence. The company transferred its property in specified territory to a gas company, which undertook to do all the business of the electric company within the specified limits. The individual continued to receive adequate service. Held that, in view of Rev. Laws, c. 121, regulating gas and electric light companies, the individual could not complain of the arrangement, and could not compel the electric light company to supply him with electricity. *Weld v. Gas & Electric Light Commissioners*. Supreme Judicial Court of Massachusetts. 84 Northeastern 101.

#### POWERS OF EMPLOYEES

Where the foreman of a force of men in the employ of an electric light and power company assigns to two designated and experienced linemen the duty of attaching a guy wire to a particular telegraph pole, they have no right or authority to substitute another person in lieu of themselves to perform this work, especially an apprentice lineman who is under the tutelage of the company, and under the orders and direction of the foreman. As they had no right and authority to impose the performance of the work on the apprentice, still less could they transfer the doing of the work as a privilege. *Maitrejean v. New Orleans Ry. & Lt. Co.* Supreme Court of Louisiana. 46 Southern 21.

#### EVIDENCE OF QUALITY OF INSULATION.

In an action for death from contact with an electric wire, testimony that "circular loom" insulation was better and safer than that used by defendant

was not admissible under the allegation that "defendant had allowed its wires to become defective in insulation and in a dangerous condition." *Von Trebra v. Laclede Gaslight Co.* Supreme Court of Missouri. 108 Southwestern 559.

ELECTRIC WIRING SUBJECT TO MECHANIC'S LIEN.

Where electric wires are inserted in a building so as to indicate an intention to make them fixtures, they become the property of the owner of the building, and may therefore be the proper subject of a mechanic's lien, under B. & C. Comp. § 5640. *Rowen v. Alladio.* Supreme Court of Oregon. 93 Pacific 929.

ORDINARY PERSON PRESUMED TO KNOW DANGER OF WIRES.

An ordinary person is held to know the danger attending contact with electric wires, and if he heedlessly brings himself in contact with such wire, and is injured in consequence, his contributory negligence will prevent recovery. *Haertel v. Pennsylvania Light & Power Co.* Supreme Court of Pennsylvania. 69 Atlantic 282.

EMPLOYEE ASSUMED RISK.

An electric light company was not liable for the death of an employe through coming in contact with a tap wire while stringing wires where the wire was clearly visible, and decedent, an experienced workman, had been informed of all the elements of danger attendant on his employment, and was permitted to perform the work in his own way, with an opportunity of unrestricted observation which the dangerous environment demanded. *Pembroke v. Cambridge Electric Lt. Co.* Supreme Judicial Court of Massachusetts. 84 Northeastern 331.

Clippings from Consular and Trade Reports.

Vice-Consul Ernest Santi, of Milan, Italy, reports that the city government has voted to obtain a loan of \$13,510,000 at four per cent. interest, to be liquidated within fifty years. The money is to be used in making municipal improvements, such as building sewers, public baths, tramways, electrical plant, new streets, etc.

Consul J. St. John Gaffney, of Dresden, states that water power is not used to any great extent in Saxony, being entirely limited to small saw and corn mills in outlying mountainous districts. He adds:

"The laws relating to the develop-

ment and use of water power give the right of concession to the ministry of public works. Before any concession is granted the applicant must file plans of the system proposed, buildings, etc., and power required. These plans are laid before the local technical commission, who report to the ministry. No large projects have been accepted during the last decade.

"The government has no water-power station in operation at present. Formerly a few turbines were in use for milling purposes on the Upper Elbe, but have been discontinued. All water-power plants at present in operation are in private hands, controlled by the government. As far as can be ascertained, there are only a few plants established, all of which develop but sufficient power for the needs of the mills which own them; no power is rented or sold.

"In the absence of any figures as to water power it is impossible to make any comparison with steam power, but the former is absolutely negligible."

According to figures presented to the Institute of Electrical Engineers the net saving over steam by the use of electricity on the railroads of the United States averages \$638 per mile, which, if applied to the entire railroad system, would effect a saving of \$138,500,000 per annum.

The American Consulate atantung, China, requests American manufacturers to forward their catalogues, preferably illustrated ones, that they may be filed at the Consulate for reference. The Consulate writes that it should be possible to create a market there for many lines of goods which are more or less in demand now, and requests as varied a line of catalogues and literature as can be furnished it.

The Chilean Government authorizes the General Director of the State Railways to expend nearly \$2,000,000 upon different works, such as electric-light installation, railway construction, and the purchase of machinery. Address General Director of State Railways, Santiago, Chile.

A concession has been granted by the Bolivian Government to Señor Leopold Meyer to construct a "decauville" line from Corocoro to Calocoto and a railway from Chacasilla to San Juanillo. He is also authorized to construct telegraph and telephone lines for the railways. Señor Meyer's address is not stated, but he could be addressed care of the Minister of Finance and Industry, Sucre, Bolivia, S. A.

Consul-General G. E. Anderson writes from Rio de Janeiro as follows in regard to the general development in Brazil:

"The service of electric power in the city of Rio de Janeiro from the great water power developed at Ribeirao das Lages was inaugurated on July 30th. The development of this power and the enterprises connected with it represent one of the greatest elements in commercial and industrial development in Brazil at the present time.

"Borings for coal are being made at Araguaya, in the State of Minas Geraes, but it is generally considered improbable that coal of any material value will be discovered. The presence of vast masses of iron and manganese ore in this State and in the vicinity of Araguaya renders the possible discovery of immense importance.

"The enterprise is now on foot, under the direction of Mr. Justin Norbert, an English engineer, of constructing a railway from the port of Paraty-Mirim, on the coast between Rio de Janeiro and Santos, with points in the northern portion of the State of Sao Paulo. The proposed road would pass through Cunha, Lagoinha and Guaratingueta, and a district running as high as 4,500 feet above the sea, rich in granite, marble, and other construction materials, and offering special inducements for the culture of Temperate Zone fruits. The State government has shown its approval of the enterprise in general, the details being yet to be settled."

The Aluminum Situation

It is understood that an agreement between the Pittsburg Reduction Company and foreign manufacturers of aluminum has been terminated, and that both English and German manufacturers are now offering aluminum at lower prices than that of the Pittsburg Reduction Company, although the latter has the advantage of a duty of 8 cents per pound. The current quotation is 33 cents per pound by the Pittsburg Reduction Company, and the English aluminum company has cut its price down to 24 cents per pound.

A business man in Belgium writes to the Bureau of Manufactures that he would like to represent some American firms in Belgium. He states that his experience has been principally in metallurgic products, chemical products and electric goods. He also offers his services as agent to American houses desiring to import Belgian goods.

# THE ELECTRICAL AGE

Volume XXXIX. Number 9.  
\$1.00 a year; 15 cents a copy

New York, October, 1908

The Electrical Age Co.  
New York.

ESTABLISHED 1883

Published monthly by

The Electrical Age Co., 45 E. 42d Street, New York.

J. H. SMITH, Pres. C. A. HOPE, Sec. and Treas.  
JOHN HAYS SMITH, Editor.

Telephone No. 6498 38th.

Private branch exchange connecting all departments.

Cable Address—Revolvab, New York.

## SUBSCRIPTION RATES

United States and Mexico, \$1.00.  
Canada, \$1.50. To Other Countries, \$2.50

## NOTICE TO ADVERTISERS

Insertion of new advertisements or changes of copy cannot be guaranteed for the following issue if received later than the 15th of each month.

## Silicon Steel

Confusion worse confounded than the situation raised by the knowledge of silicon steel leaking out to the electrical trade has not occurred since the early days of Tesla's induction motor experiments. Large and thick pamphlets about the manufacture of steel (steel only) are going out to the trade. But not a word about silicon. Wild editorials about the effect of the new steel on the design of apparatus by people who know not, and wild advertisements tantalize our eyes. And pray, what is the difference between plain silicon steel and silico-vanadium steel?

Even the ghost of "aging" is resurrected for us to stare at again!

In speaking of the maximum temperature rise in a transformer, the *Electrical World* in its issue of Sept. 12th, says editorially—the italics are our own:

"Thus the character of constructive material used in the past has rendered it desirable that a temperature of 75°C. be not exceeded, or that the rise be not greater than 50° C. above an arbitrarily assumed room temperature of 25° C. These limits have been set, partly on account of the slow destruction of the insulation, *but more largely by reason of the 'aging' of the core material at high temperature.* The 'aging' effect is cumulative. The high temperature causes an increase in the core loss, which not only lowers the efficiency, but increases the temperature and thereby augments the rate of increase of the core loss and the temperature rise. An article by Mr. T. S. Allen in this issue reports the results of some tests on core material, containing among its so-called impurities about three per cent. of

silicon, which is practically free from any 'aging' whatsoever. It would seem that when material of this nature is used, the allowable maximum temperature might well be placed at a value much above 75° C. without affecting the life of the transformer. *Moreover it might prove more economical to operate at a higher temperature and thereby obtain low-priced transformers to be replaced at certain intervals, rather than to pay the interest on high-priced long-lived transformers."*

The editorial above quoted was evidently inspired by some published experiments of T. S. Allen, comparing silicon steel with ordinary steel. Mr. Allen found at a density of about 10,000 lines per sq. cm. aging of approximately 20 per cent. in one sample, 40 per cent. in another sample of ordinary steel, and of course nothing appreciable in silicon steel. If aging were present in transformers to this extent there might possibly be an excuse to "editoriate" on the subject, but it is not. The large manufacturers have taken contracts for transformers for nearly ten years back on a guarantee that the aging would be less than 5 per cent. in one year, and everybody who has bought them knows this fact. And a 5 per cent. increase in core loss is so trifling that the question of aging in transformers has not lately assumed any more importance in making a sale than the pattern of the terminal block, or other matter of minor importance.

The statement of the editorial that the elimination of aging now makes it possible to run transformers at higher temperatures shows therefore an ignorance of present commercial practice. But suppose it were true that aging had been a bothersome problem to transformer designers and that silicon steel now removes the question of aging from consideration. The statement is still in error, as it never has been the practice to spare the transformer for the sake of the iron loss, but rather to guard it against excessive overload because of the danger to the insulation from high temperatures. This danger is two-fold. High temperatures bake the fibre and paper which enter into the insulation and deteriorate it rapidly; and they produce troublesome extensions and displacements of the wires in the coils due

to unequal temperatures. It is not an infrequent thing to find in transformers which have burned out whole rows of wire displaced from their normal position, with one wire cutting across another one. With the alternate heating and cooling of the transformer the wires abrade and cut the insulation. This is the actual condition confronting the designer and operating temperatures will probably remain as they are until some one discovers a pliable insulation with the heat resisting qualities of mica.

Speaking of a further conclusion of the *World* editorial, namely, "it might prove more economical to operate at a higher temperature and thereby obtain low-priced transformers—rather than pay the interest on high priced, long-lived transformers," the writer must be ignorant of the fact that high-priced, long-lived transformers are a natural development which the central station has demanded in order that it can give the public a *reliable service*. Let a defective transformer throw the lights out in a church, hall or at a social gathering, and the price of a hundred transformers would not repay the damage to the reputation of the operating company.

But let us assume that the necessity for reliability does not hold, and consider a 20 kw. transformer carrying full load at 50° C. rise. Put 25 per cent. overload on it and it then becomes a 25 kw. unit. A 25 per cent. overload would give it an operating temperature of 70° C. The price of the 20 kw. unit is \$290, and of the 25 kw. unit about \$42 higher, or 15 per cent. more. To justify running the 20 kw. at a 25 per cent. overload continuously while on current, would require that it run about seven years to save its cost. Does anybody think it would run one year!

Of course, if the material in a 20 kw. transformer were intended for a 25 kw. output the design would be modified, but it would hardly affect these figures.

Our obvious duty to the profession of clearing up such a mess of technical error has brought us far from the matter of silicon steel and we will proceed straight to that subject.

Silicon steel was brought to this country from England by Robert A. Hadfield, who has lately been knight-

ed by King Edward for his services. It was about four years ago when he offered the process of its manufacture to the General Electric Co., and afterwards to the Westinghouse Co., both of which declined to purchase his American patent rights. Each of these companies had spent years in experimentation and had succeeded by the expenditure of a great deal of money in producing practically non-aging steel, so that this aspect of the situation did not particularly appeal to them.

Each of them had its steel made under its own specifications and enjoyed the full use of a steel plant for experimentation. Consequently the General Electric Co. began to study the effect of large quantities of silicon on steel, and to have silicon steel made for its use. A recent publication of the company, entitled "Transformer Steel" asserts:

"Nearly twenty years ago the engineers of the Thompson-Houston Company made the discovery that certain impurities in iron greatly improved its electrical characteristics." But on this point there seems to be some difference, as in discussing A. H. Ford's paper on "Hysteresis in Sheet Iron and Steel." (A. I. E. E. April 25, 1900.)

Dr. Steinmetz remarked, "It only shows again that the chemical constitution has nothing to do with the hysteresis and that hysteresis loss depends largely on the physical condition of the iron, and on the chemical constitution probably only indirectly in so far as the physical constitution depends on the chemical to a certain extent."

The same pamphlet also states that Dr. John F. Kelley, then with the Stanley Co., found several years ago that steel having a small amount of silicon showed some improvement over ordinary open-hearth steel. Kelley's patent is twelve years old and therefore antedates the production of non-aging steel.

Hadfield, being unable to sell his patents to the two large companies, sold them later to the United States Steel Corporation, who at once began to manufacture and sell the stuff, and who alone manufacture it, except what is made by the General Electric Co.

Consequently, last year all of the smaller manufacturers purchased the new steel of the steel corporation and began to advertise it. The General Electric Co. had been using the new material now two years, and the Westinghouse Co. perhaps one year, without saying anything about it to the trade.

Every engineer should bear this in mind, that all of the steel is of United States Steel Co.'s manufacture, and

there are no differences—with one exception, that made by the General Electric Co.

Consequently, different claims based on the steel, or on special steel, are fallacious. One manufacturer is talking much of silico-vanadium. We are of the opinion that the stuff contains no vanadium, or only enough to justify the name, and not enough to affect the physical qualities of the metal. Vanadium is used to harden and strengthen steel, being much used in automobile parts; but why such a property is desirable in transformer plate, which is so carefully held together, and never subjected to strain, is not understandable.

The real facts about silicon steel are, that it is practically non-aging and gives a core loss about half that of the best sheet hitherto known. It is understood that the sheet manufactured for one large manufacturer shows 0.8 watts per lb., while that of the United States Steel Corporation gives a loss of about 0.6 watts per lb. In the design of transformers this difference is so trifling that it does not make much difference. Even sheet made by one process will show quite as much daily variation in manufacture. We understand on the very highest engineering authority that the hysteresis loss can be brought down to 0.36 watts per lb. The permeability of the new steel is slightly under that of the ordinary sheet.

The effect of the new material upon the design of transformers is as follows:

The use of this material does not in itself affect the type and proportions of transformers; *i. e.*, no changes would be required in fundamental principles of transformer design. The lower losses per unit weight of material naturally allow either a saving in material for a given performance, or a lower cost, or both, depending on the design made. Densities in the use of this material would undoubtedly go higher than 7000 c.g.s. lines. The densities would go up as the amount of material is decreased, the upper limit being governed by the questions of permeability and of heating.

Assuming no change in design, the weight of iron would be a function of the loss, but would probably not vary directly, as there are many things to consider in a practical design which would bear on this subject and which will be modified by the necessarily modified dimensions of the design.

The two main things to consider in any transformer design are cost and performance. A transformer design is so flexible that, given copper of a certain conductivity and iron of a certain loss and permeability we can

make any set of assumptions within very wide limits and work out the problem. The customer is interested in both cost and performance, and, if we assume iron having a loss of one-half of that of iron previously available, the customer will probably demand that he receive the benefit in lower total iron losses. If we should design for the same losses as given by the higher loss iron, the cost would be very considerably reduced. If we retain the same cost and get all the benefit possible in performance, a certain minimum loss will result. If we reduce both loss and cost, a compromise between extreme low cost and extreme low performance must be made. Yet it should be noted that the relation between cost and performance is not a straight line function and that, after certain limits are reached, very great cost must be resorted to in order to give extreme low losses; and, in like manner, for a given cost of material, the loss cannot be commercially reduced below a certain amount.

In like manner, given a certain conductivity of copper and a certain loss in iron per unit weight, the design may be juggled to secure either extreme low copper loss or extreme low iron loss, but there are practical limits in both cases beyond which it is impossible to go on account of concentrating the loss—either copper or iron, in an amount of material which will cause it to heat beyond the danger point. The effect therefore of the low iron loss would be in the main to reduce both copper and iron, the amount of reduction being controlled to a considerable extent by the particular design. To sum up, the general effect of the use of material of relatively low loss will be to increase the efficiency, to better the regulation, and to decrease the weight. The effect of the leakage current can only be determined by the particular design, but extreme increase in leakage current or decrease in power factor should not result with proper use of the material.

Which leads us to remark that changes have been made in some makes of transformer which have produced a unit having a considerable higher leakage current than was customary in the older designs. The wisdom of this change is somewhat open to question from the standpoint of the large central station, owing to the fact that during the period of light load it would be necessary in the course of time to operate additional generator capacity to supply the extra leakage current.

In a system having an aggregate capacity of 10,000 kw. connected to its

lines, the increased leakage current, if all the transformers were of the recent design, would amount to between 300 and 400 k.v. amperes. With a station using 500 kw. generator units this would in many cases necessitate the operation of an additional unit for the purpose of supplying the leakage current during the late hours of the night, and in some cases throughout the daylight hours.

From the viewpoint of the central station engineer it would therefore be much more desirable if advantage were taken of the improvements of the steel manufacturer only up to the point where the leakage current and light-load power factor remain as approximately the same as under the old system of manufacture.

One of the large manufacturers who designed a new line of transformers with a heavy no-load current has altered the design of them so that the leakage current is now less than in transformers built of old iron.

With regard to machines, the bettering of design does not depend on getting extremely low loss material so much as the getting of a material having a higher permeability, the limit being one of saturation in many cases; rather than of losses. This is not true of all designs, and, where it is a question of heating due to iron losses and the permeability is of not so much importance, the new material will undoubtedly be used. The extreme gains claimed for transformers will not, however, be realized in machine work. The general result in machines will possibly give a small reduction in both iron and copper for a given performance.

**An Old Controversy**

Visitors to the recent Electrical Show at the Madison Square Garden, New York, were confronted by a striking exhibit of the Brooklyn Edison Company, containing a gas engine, a steam engine and boiler, and a motor, all in full operation.

Near the gas engine was posted a notice purporting to give the cost of operation of such a plant of 25 h.p., and similar placards were placed near the steam engine and the motor. The figures on these placards were reprinted in a folder, and were as follows:

GAS ENGINE	
<i>Price, complete, \$1,200</i>	
(Details of monthly cost of running)	
Gas, at 80 cents.....	\$57.20
Oil, waste and incidentals.....	4.50
Water.....	3.00
Repairs, average of 5 years.....	5.00
Interest and depreciation, 15 per cent.....	15.00
Labor.....	8.00
	<hr/>
	\$92.70
Additional 20 cents which the Gas Co. proposes to collect if successful in pending litigation.....	14.30
	<hr/>
	\$107 00
Increase—8½ per cent. over electric motor drive.	
Add to this:	
Noise.	
Smell!	

Oil splash.	
Dirt.	
Vibration.	
Insurance.	
Less production.	
Value of floor space.	
<b>STEAM ENGINE (BOILER INCLUDED)</b>	
<i>Price, erected, \$1,000</i>	
(Details of monthly cost of running)	
Fuel.....	\$46.70
Oil, waste, packing.....	7.50
Water.....	4.00
Labor.....	60.00
Repairs, average of 5 years.....	5.00
Interest and depreciation, 10 per cent.....	8.33
	<hr/>
	\$131.53
Increase of 33¼ per cent. over electric motor drive.	
Add to this:	
Noise.	
Vibration.	
Insurance.	
Value of floor space.	

ELECTRIC MOTOR	
<i>Price, motor and wiring, \$435</i>	
(Details of monthly cost of running)	
Electric current from Edison Co., maximum demand contract.....	\$94.54
Oil.....	.10
Repairs and brushes.....	.50
Interest and depreciation, 10 per cent.....	3.60
	<hr/>
	\$98.74
By installing several smaller motors in place of one large one and eliminating shafting, this amount may be reduced from 10 per cent. to 50 per cent.	

As these figures are misleading, fairness to the interests of all concerned calls for an analysis of them. It would be an economic mistake to replace a steam or gas engine by an electric motor, the sole and governing consideration being cost; if it turned out afterwards that the motor cost more in operation than the engine! The injury would react at once on the central station and indirectly on the manufacturers of motors.

Considering the gas engine first, the item for fuel is about correct, but the costs of oil, labor and the fixed charges are excessive, given the usual working conditions. With respect to the oil and waste item, \$30.00 per year is ample allowance; no charge should be made for labor, as where such plants are installed a man connected with the establishment, usually a machinist in charge of other machinery, takes care of the gas engine without additional pay, and no saving would be made in his pay by not having the gas engine in operation. As for the fixed charges, if 5 per cent. is allowed for interest and 6 per cent. for repaying the investment, this should be ample if in addition to this 5 per cent. or \$5.00 per month is to be allowed for repairs.

With these modifications, the cost at 80 cents in reduced to \$67.70 and the saving over the electric motor \$31.04, or \$362.48 a year, or over 25 per cent. It should be borne in mind too that these figures are on a basis of half-rated load for the plant—a very inefficient condition for the gas engine, but not for the motor.

In regard to the steam engine plant, the figures are entirely theoretical and not based on practical results. No credit is given the steam plant for the value of the heat in the exhaust steam for heating the building or for heating water or drying, and in almost every

case this steam can be used for a great part of the year, making the cost of fuel for power production almost a negligible quantity.

The cost of oil, waste and packing, \$90 per year, should be oil \$15.00, waste \$5.00 and packing \$5.00, or a total of \$25.00. Water would be about correct if the exhaust steam were not used in the heating system and then returned to the boiler. Where it is reused, the cost drops from \$4.00 per month to about 50 cents.

In the item of labor, no allowance is made for the need of a man to run steam heat during seven months, but this may be justifiable in some instances.

Our estimate of the cost of operating a small steam engine under usual conditions, with steam required for heating and manufacturing, would be:

Fuel, six months, at \$46.70.....	\$280.20
Oil, waste, etc.....	30.00
Water, six months at \$0.50 } .....	27.00
Water, six months at 4.00 } .....	
Labor, six months at 30.00.....	180.00
Labor, six months at 60.00.....	360.00
Repairs.....	30.00
Fixed charges.....	100.00
	<hr/>
	\$1,007.20
Average cost per month.....	\$83.93

In regard to charge for electric motor, the amount \$94.54 for electric current is arrived at as follows:

Under the new maximum demand contract of the Brooklyn Edison Company the contract is based on correct principles—i. e., a basic charge for first hour's use, to cover fixed charges, additional hours' use at rate to cover operation and distribution cost, plus fair profit.

On the 25 h.p. installation, the maximum demand is figured at 65 per cent. connected capacity, and on this basis the first 25 hours' use per month is at 10 cents per kw-hr. § The 3 cent charge being subject to a discount of 10 per cent.

On an equipment of 25 h.p. 65 per cent. is 16¼ h.p. If this is used an average of one hour per day for 25 days the total per month would be 406¼ h.p.-hr. or about 300 kw-hr. This is what is meant by one hour's average use of the equipment per day, or the first 25 hr. use per month.

It may be well to point out that the rates in Manhattan and other districts less fortunate than Brooklyn are double the rates for the quantity stated.

The Brooklyn Edison Company is, of course, correct in pointing out the great convenience of the motor in such small installations, and no serious fault can be found with their conclusions as to the advisability of its use in such small installations, were it not that the figures of relative economy might give rise to erroneous conclusions in larger installations and in other localities.

§The next 25 hours' use at 5 cents and remaining at 3 cents per kilowatt hour.

### Electrical Shows

We are born to do benefits.—Shakespeare.

Extract from a Folder Distributed by The New York Edison Co. at the 1908 New York Electrical Show.

The annual electrical fair has ever been a popular institution. New York has had one of varying character for many years; Chicago has presented a splendid one for the last four years; and now Boston proposes to have one also; and for aught that we know there are embryonic shows in other towns in the chrysalis stage, waiting for an angel to warm them into life. We speak therefore of one which is most familiar to us and from which future showmen can learn much.

#### THE NEW YORK SHOW.

Annual electrical shows have been held in New York for many years in the Madison Square Garden, which has a floor capacity of approximately 35,000 sq. ft. If all of this space were sold, the affair would be immensely profitable. But usually it has been impossible to interest enough manufacturers in New York, owing to the small number of electrical buyers who visit these shows, and the lack of confidence in the management of them, which has not always been unjustly withheld.

Last year, after a succession of indifferent shows, a new set of men took charge of affairs in New York—Mr. Arthur Williams, well known of the trade, and Mr. George F. Parker, who is understood to have shown some talent as a circus showman. The annual show was to be rejuvenated.

About 10,000 sq. ft. of space was sold, the remainder was given away or sold at a reduced rate, and there was an absence of the fakir, pop-corn vendor and various ill-assorted attractions that made the place in other years seem like an electrical garden overgrown with Coney Island weeds. Five thousand six hundred dollars worth of space was given free to one of the large manufacturers; \$2600 worth to another one, and \$800 worth to a fixture house who never before had made an exhibit at an electrical show.

The New York Edison Co. paid for a \$2000 space and used about \$5000 worth; the Brooklyn Edison Co. paid for and used only \$1700 worth of space, being the only large exhibitor to do so. But if the dear reader imagines that this rejuvenated show was going to lose money as an enterprise, he is mistaken. We beg to assure him that it earned something over \$15,000, and with large-handed gratitude paid out about \$1,800 to the exhibitors as a bonus and reward for their business acumen in making an

exhibit. We must hasten back however to our tale.

#### THE START.

The show was started in 1907 as a "shoe-string," which in homely language means that nobody in particular, or no set of nobodies, put any considerable sum of money into the enterprise. It was incorporated for \$30,000, but we are reliably informed that no stock was paid for by the holders of it and that the small sum furnished by the manager of the show to start the affair was repaid him at the end of the show.

Not that money was not needed in such a venture. It was. The manager needed \$100 a week, and then some others needed money also. The needed working capital was secured by getting 25 per cent. of the cash value of the exhibit contract in advance.

#### HOW TO GET A CROWD.

In order that there should be an audience, the exhibitors invited their friends, acquaintances and business associates to come to the show and presented them forthwith of a ticket of admission.

Had the newspapers advertised the show as free, and had the doors been without keepers, we are sure none but inquisitive persons would have come in.

But here is where the clever showman takes advantage of our curious American habit of getting something for nothing. Everybody got a piece of pasteboard and everybody went. Such crowds had seldom crowded into the Garden. No matter that nearly everybody went in on a free ticket. The entering public believed it was getting something for nothing, and it did.

So here is one secret of making a successful show.

#### PROFITS FROM THE SALE OF TICKETS.

But let nobody imagine that nobody paid for these tickets. They did.

They paid 12½ cents apiece, except that the New York Edison Co. and the Brooklyn Edison Co. paid only 10 cents for theirs. This was allowed them by the board of directors, both because they had been good customers of the show and had given much outside assistance in its promotion. There was of course more onerous work for these directors—seven of them—because they were more highly paid than half of the bank directors of New York, and equally as much as those of the United States Steel Co. and the General Electric Co. To each of them went \$20.00 in gold. While we have no minute book of the New York Electrical Show, we are inclined to believe

from our knowledge of human nature that there never were any avoidable vacancies in the meetings of this highly paid lot of men who made success blossom out of last year's withering show.

But let us see about those tickets. The New York Edison Co. distributed about 85,000 tickets, paying the show \$8500 therefor. Here was enough money to run the show for three days. The Brooklyn Edison Co. used about 25,000 tickets. Here was \$2500, nearly enough to run the show a day. Various other exhibitors put up perhaps 50,000 more, or enough to run the show for two days. Here alone were receipts for seven days. It was open only nine days. By the way, the General Electric Co. and the Westinghouse Co. bought about \$1500 each of tickets.

From the sale of these tickets to exhibitors and from the sale of box-office tickets of admission at the straight garden price of 50 cents, and from the sale of space, enough money was paid to show a profit of over \$15,000.

It is to be remembered that this excess came chiefly from the wholesale "sale of tickets" as distinguished from "admission at the box office." And had it not been for these the show would not have been profitable and the "get-something-for-nothing" public would not have been there.

And here is another secret of making a show profitable.

#### REFUND TO EXHIBITORS.

In order to sell these tickets the president of the show, Geo. F. Parker, sent out the following letter:

July 27, 1907.

GENTLEMEN:

The management of the First Annual Electrical Show, to be held in Madison Square Garden, September 30th to October 9th, 1907, makes the following offer to its exhibitors:

With the desire of sharing any profit that may be made from this show, it is proposed to share with the exhibitors (in proportion to the payments made for space) the receipts from the sale of tickets and of admissions at the box-office. With this end in view, 50 per cent. of these receipts will be returned to the exhibitors, and they may take such steps as may seem desirable to them to verify the records.

Tickets will be distributed on the following basis: Each exhibitor will be entitled to one ticket of admission for each dollar or rental paid for space; additional tickets may be purchased in lots of 100 at 12½ cents each; as half of this will be returned to the exhibitors in proportion to their rental, the net price thereupon becomes 6¼ cents each.

The effect of this method, in addition to sharing the profits of the exhibition, will be to greatly increase the attendance. This will net the exhibitor a large dividend on the money invested, aside from the great benefits derived from the maintenance of an exhibit, to say nothing of the future results the exhibitor receives through the publicity created for his wares by the show.



Is not a personal interview with the buyer, and a practical demonstration, the best medium for selling any product?

You can accomplish this to a greater extent by exhibiting at the Annual Electrical Shows than in any other way.

We will be pleased to furnish you, upon application, a floor plan of Madison Square Garden showing locations of space and the rules and regulations for the installation and maintenance of exhibits.

Awaiting your early reply, we are,

Very truly yours,

ELECTRICAL SHOW,

GEO. F. PARKER,  
*President.*

It will be noted that the promise covered not only "admissions at the box office," but the "sale of tickets," and that there be no misunderstanding about this matter they were informed that "half of this will be returned to the exhibitors in proportion to their rental, the net price thereupon becomes 6¼ cents each."

The amount of money which was actually returned under this promise was 15 per cent. of that paid by exhibitors, or 18¾ cents per sq.ft. on a rental value of \$1.25 per sq.ft. Assuming that all of the Garden space was sold (35,000 sq.ft.), which it was not; but assuming that it was, there would have been paid out under this bonus guarantee \$6560, and double this amount should be \$13,120, supposedly the admission receipts.

But the total admission receipts were not under \$25,000! The only possible explanation is that there was a mental reservation, a withholding from the reckoning of tickets purchased by some company or companies; or the officers, who alone knew what they were, deliberately determined the size of the refund, salving their conscience by the thought that this was bounty and that too out of their own pockets. It is only about half the amount. But let it stand at that figure, and the refund at \$6560, as we reckon it, on the entire space.

Even this sum was not paid out, as only exhibitors who paid for space got this refund under the circular letter proposition.

Let us see how much did go out—well, there was about 10,000 sq.ft. of space sold, which amounts to \$12,500. Fifteen per cent. of this amount was \$1875, so that nearly \$5000 of the amount promised exhibitors was withheld—and we estimate above that this is only about half of the real amount! We are not interested in what became of it. We are interested only in getting the cost down to as low an amount as possible to electrical manufacturers who display at such shows.

But let us lay aside these sordid details of management and have a view of the hippodrome itself looking

at the show of 1908 which has just closed.

#### A BIRD'S-EYE VIEW OF THE SHOW

There was the usual wireless telegraph outfit which has so generally in former days stimulated the public to buy its stock, and this year we had the wireless telephone exhibited by a company which is now asking the public to buy stock.

If you were going to an electrical show and were told that out of twenty odd manufacturers of motors you would find only one exhibiting; if you found only one wire and cable house out of a dozen concerns making a specialty of this line; if you found only one conduit manufacturer; and you found no switchboard stuff, and no storage battery, with the only machinery exhibited by one large manufacturer, would you believe you were visiting an electrical show that was worth while? Not if you were an electrical engineer. But there were things electrical on exhibition. There were some three firms making electric lighting fixtures, five flaming-arc exhibits, three different displays of electrical signs, three different varieties of vacuum floor-cleaners, etc., with "Bill Devery's" burglar alarm, an assortment of Siegel-Cooper's pickles and Bloomingdale's flowers, and all sorts of things that interest the householder who is using electricity or is going to. Judged as an effort to reach this class of people, the show as a spectacle might be designated as a success; judged from the point of view of the manufacturer who was reaching for his trade we are afraid, much as we dislike to say it, the show was a failure.

Why did not the Crocker-Wheeler Co., the Allis-Chalmers Co., the Western Electric Co., the Electric Storage Battery Co., the Westinghouse Co., and various other large concerns stay out of this show? Was it lack of confidence or was it because they clearly realized after all that the show is largely a household utility affair. We incline to the latter view, though we see no reason why those manufacturers who have something the public buys should not exhibit even at a show primarily laid out for the public.

There are really two kinds of customers and two kinds of electrical fairs: One which displays apparatus of interest to the technical man or engineer; and another one displaying electrical goods intended for general public use. All manufacturers are interested in the first kind, and only those who make stuff to hitch on a central station circuit are interested in the second kind. You can make up your mind which show you will have. You can only have one.

#### THE COST OF DISPLAY

More manufacturers ought to exhibit at these electrical fairs but the cost is almost prohibitive, as they are managed under private enterprise. Thus in Chicago the cost is \$1.50 per sq.ft. with no extras for a 12-day show. In New York the cost is \$1.25 per sq.ft. for a 10-day show, the exhibitor paying for the erection of his own booth and all the wiring, with \$10.00 to cut his current meter in, and \$1.00 per night for janitor or watchman service, making a total of from \$2.00 to \$2.50 per sq.ft.

Under a co-operative effort these fairs could be held at about half the usual cost. The cost of putting on the largest affair of its kind in America, the apparatus display of the American Street Railway Convention, was this year only about 28 cents per sq.ft., everything found, with a total of nearly 60,000 sq.ft. The National Electric Light Association carries on a display exhibit which costs all told about \$100 per booth for each exhibitor.

Our proposal that these affairs be carried on by a co-operative association of the manufacturers is not therefore novel, since in both of these conventions the thing is practically done that way; and as we go to press we are advised of a co-operative electrical fair at Manchester, England.

#### William S. Murray on Electrification

William S. Murray, electrical engineer of the New York, New Haven & Hartford Railroad Company, which has been operating the Westinghouse single-phase electric railway system on a part of its lines during the last two years, in discussing their experiences with electrification, says:

"The most commercially valuable answer as to the success of electrification on the New Haven is written in the actual operating schedule in the electrification zone. The train minute delays suffered to-day by electrical operation are but a small percentage of those incurred during the period of steam operation.

"As the zone limits in our case were not a terminal proposition, the application of the direct current showed itself to be impracticable. On account of errors, always common of initiative work, the first few months' operation has been a period of interruption which has naturally been annoying both to the road and the public. To-day the delays have disappeared by the removal of their cause.

"The wisdom of the purchase of a locomotive consisting of two individ-

ual half units, the whole or half unit being operative by a single crew, has proved itself in the ability of the road to handle 75 per cent. of traffic with half unit locomotives, using the whole unit on the remaining 25 per cent. of trains, whose weight demands the full drawbar. Should future requirements see the advantage of extension of electrification east of Stamford, the system is designedly applicable.

"As to the saving in cost of operation as compared with steam, I would state that operation to-day has not been a sufficient length of time to make this comparison. It may be interesting to note, however, that by exhaustive investigation I have found that one pound of coal burned under the boilers of our central station produces twice the drawbar obtained by one pound of coal burned in the fire boxes of the steam locomotive, or in other words, the fuel bill for electric traction is one-half of that required for steam traction. Other economies will arrive in the low cost of maintenance and repairs of the electric locomotive as against steam locomotives.

"The density of traffic is, of course, the paramount feature as to the savings to be effected by electrification. It is not to be forgotten that, in electrifying, interest, depreciation, insurance and taxes follow closely on the heels of the capital investment in equipment and material necessary to electric operation. The heavier the traffic, the greater will be the economies derived from the two above mentioned sources.

"It is quite conceivable that the heavy ton-mileage in freight and passenger service on the Atlantic coast line roads will effect savings sufficient to cover the above-mentioned fixed charges on the investment necessary to their electrification.

"The greatest value to be experienced by electrification will be in the tremendously increased traffic capacity of the present track mileages, due to the facility electricity offers in making rapid main line and yard train movement."

#### The Allis-Chalmers Annual Report

President Walter H. Whiteside is to be congratulated on the splendid showing of the Allis-Chalmers Co. during the last year.

At the time he took hold of the company, the works were being operated at a loss, notwithstanding the abundant prosperity of the country and the high earnings of its competitors. For the year 1906, the earnings of the company were \$648,000; in 1907 they practically doubled, amounting to \$1,226,000; and in the

year ending June 30, 1908, the earnings doubled again, reaching the handsome sum of \$2,574,000, showing a surplus over fixed charges of \$615,814, or 3.81 per cent. on the \$16,150,000 preferred stock.

In his annual report President W. H. Whiteside says in part:

"Beginning with the second quarter and continuing for half of the company's fiscal year, owing to the severe contraction in general business throughout the country, the volume of the company's sales averaged about one-half of normal. During the last quarter there was a gradual and steady increase in orders booked."

"Noteworthy success has been obtained in the sale and operation of our new lines of production, namely, gas engines, steam turbines, hydraulic turbines, and electrical apparatus which are now among the standard products of our company. The extended use of these lines of production, often in connection with our older products, not only by purchasers who have long been our regular customers, but by numerous new customers in almost all classes of industry, forms the basis for an increasing and profitable business."

Comptroller Thompson points out as the noteworthy features of the year disclosed by the balance sheet the material reductions in the inventories amounting to \$2,518,841; the increase in notes and accounts receivable of \$272,137; the increase in cash of \$1,059,300, and the decrease in accounts and notes payable, amounting to the substantial sum of \$2,304,413. These changes together with the net profit on the operations of the year not used for additions to plant and equipment have considerably strengthened the position of the company and increased its working capital.

#### Electric Exports

There has been a great deal of money spent by American firms in the search for foreign business. We are inclined to believe that the money would be more judiciously spent in enlarging the domestic market. In the year ending June, 1908, the total exports are a trifle under \$8,500,000, with largest exports to Mexico, Brazil and Japan.

For 1907 the figures are less than for 1906 in the following countries: United Kingdom, British North America, Cuba, Argentina, Philippine Islands and British Africa. Figures for 1908 are less than 1907 for the United Kingdom, France and British North America. Exports to the United Kingdom have fallen off more than 30 per cent. since 1906, the shrinkage mainly occurring for the

year 1908; to France the shrinkage for the year 1908 is about 15 per cent. under 1907. The German market is ridiculously small, running about \$100,000 for 1906-7-8, only about a tenth of 1 per cent. of the manufactured German product.

In exports to other countries in Europe the amount is a little under one-half million dollars and practically stationary for 1906-7-8.

The shrinkage of exports to Canada since 1906 is about 60 per cent. Mexico, however, shows an increase of about 30 per cent. since 1906. Cuba, on the other hand, shows a decrease of more than 50 per cent. from the figures of 1906; Argentina shows a gain of 1000 per cent. for 1908 over 1907; Brazil shows a gain of nearly a 100 per cent. in 1907 over 1906, and over 20 per cent. for 1908 over 1907. Export trade to the remainder of South America is practically stationary for the three years.

In the far East, the British East Indies and Japan, appear to be a growing market, and the Philippine Islands, Oceania and British Africa show a substantial increase.

The total exports from the United States are less than 4 per cent. of the total electrical product manufactured in this country, and the business is chiefly gotten, not by advertising and direct trade-work, but by trade connections with New York exporting houses.

#### The Valuation of a Steam-Power Plant

Chas. T. Main, of Boston, an engineer of wide experience, says:

"With good water and good care, running about 12 hours a day, the life of a boiler should be about 20 years, or the depreciation 5 per cent. a year. Slow-speed engines, running 10 hours a day, can be estimated as having a life of about 25 years, or a depreciation of 4 per cent. a year. High-speed engines are much shorter lived, and will not average over 15 years, or a depreciation of about 7 per cent. a year; and often times it is greater when run 10 hours a day. The depreciation when run 20 to 24 hours a day is correspondingly greater. Boiler settings and piping should be included with the boilers, and engine foundations and piping with the engines.

"The life of economizers varies with the initial temperature of the entering water from about 10 years up to 40."

# Overhead Construction

## Line Work and Accessories

H. B. Gear, General Inspector, Commonwealth Edison Co., Chicago, and P. F. Williams.

THE physical characteristics of the wood used for cross-arms must be carefully considered in the selection of arms for distribution work. Long-leaf Southern pine and Oregon fir are the most used woods, because of their straight grain, high tensile strength of fibre and durability. Oregon fir is probably the most durable wood for this purpose, many cases being reported where cross-arms of this wood have remained in service on important lines upward of ten years. The chief cause of deterioration in cross-arms is the alternate action of the sun and rain, which tends to open up cracks on the upper side, allowing water to soak into the wood and create conditions which are favorable to processes of decay. It is therefore important that the top surface of the cross-arm be rounded off so that the water will run off easily.

The cross section must be of such shape and area that the arm will bear the weight of a lineman in addition to that of the wires, without danger of breaking. This demands a good factor of safety to provide for proper strength after the arm has become weakened by partial decay. Experience has proven that a cross section  $3\frac{1}{4}$  in. wide by  $4\frac{1}{4}$  in. high is ample for the average requirements of distributing lines. In hanging transformers of 20 kw. and upward it is desirable to provide special arms of a larger cross section on account of the weight to be supported.

At corners, terminals and where any unusual strain or extra weight is to be supported, the pole should be fitted with a double-arm equipment, so that the strain will be carried by more than one support. In turning corners with a single pole, the double arming of both sets of arms makes the pole difficult of access to linemen, and it is preferable in case there are more than two cross-arms to do the double arming on the first pole away from the corner pole in each direction and support the strain of the line by means of head-guys to the corner pole.

Where feeders of No. 0 or larger are carried on a center arm, the arm should be doubled if it is over eight feet long, to prevent distortion at the outer ends.

The appearance of a distributing line is best if a uniform length of cross-arm is used. In suburban districts main lines are commonly of six- or eight-pin arms with four-pin arms on the distributing mains.

In city work where both light and power secondaries must frequently be carried on the same arm, it is found necessary to use six-pin arms for distributing lines with eight-pin arms on main lines.

Where lines are occupied jointly with other companies, it is desirable that arms of approximately equal length be used by both companies.

The appearance of lines is greatly enhanced by a quiet color of paint, such as dark green, and the same color is often used on both poles and cross-arms.

The spacing of pins should be suited to the voltage of distribution, should provide a safe working space for line-

men and should take into account the average sag of the wires. Under the usual working conditions of distributing lines it is not safe to attempt to use spacings less than 12 in. and 14 to 16 in. between centers is more commonly found. Increased spacing results in arms of excessive length where eight-pin arms are required. In general, the wider spacings are common on four-pin arms and the narrower on eight-pin arms. This spacing of pins is sufficient to prevent adjacent wires from swinging together in a storm and burning off with spans of ordinary length. With longer spans more space should be provided, the spacing being approximately equal to the deflection of the wires. The spacings of pins next to the pole must

be such that sufficient room is left for linemen to get up through the lower wires safely to work on the upper arms, at least 24 in. being required with primary lines. Specially wide spacing is desirable between the pole pins of arms used on corner poles, as the space occupied by two sets of cross-arms is so great that the climbing of such a pole may be very hazardous if extra spacing is not provided. From 34 to 40 in. between pole pins is desirable for such arms.

The dimensions and spacings used by one large system are shown in Fig. 1 and Fig. 2.

In cities like Chicago, where the system of alleys is very general, these

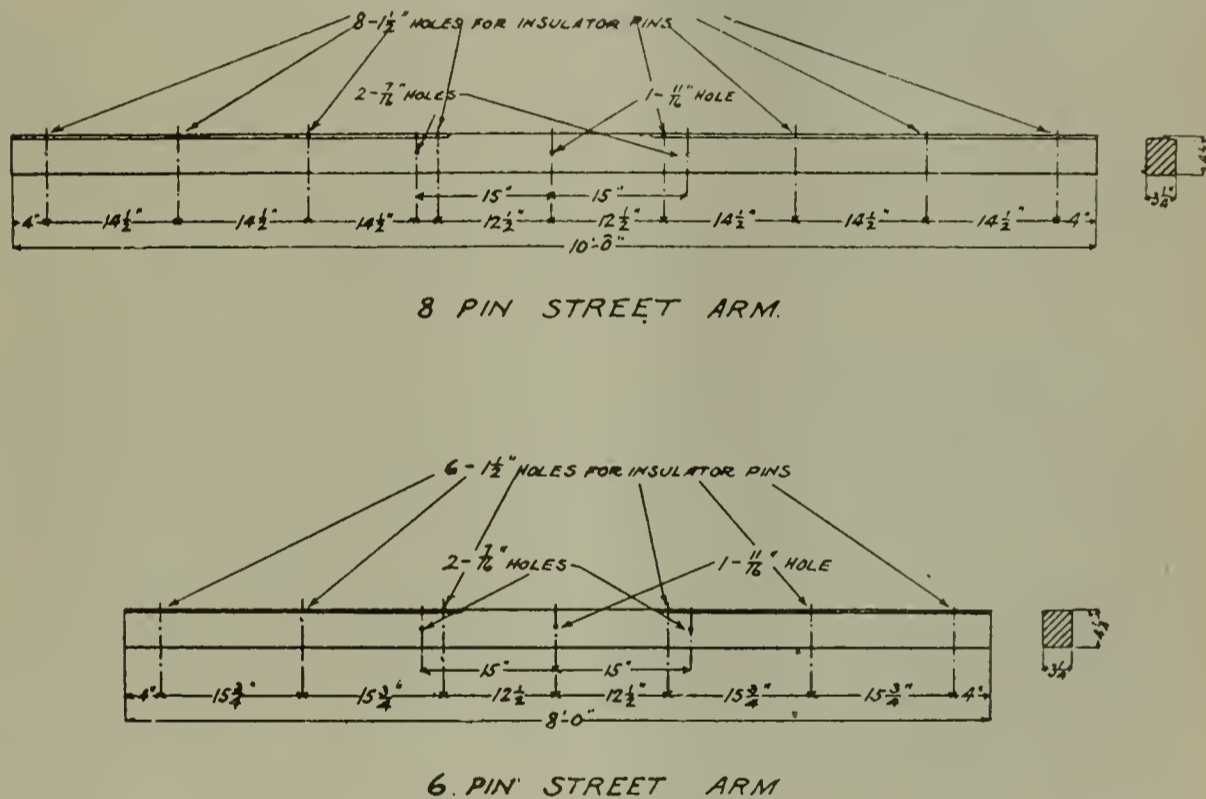

Fig. 1.

men and should take into account the average sag of the wires. Under the usual working conditions of distributing lines it is not safe to attempt to use spacings less than 12 in. and 14 to 16 in. between centers is more commonly found. Increased spacing results in arms of excessive length where eight-pin arms are required. In general, the wider spacings are common on four-pin arms and the narrower on eight-pin arms. This spacing of pins is sufficient to prevent adjacent wires from swinging together in a storm and burning off with spans of ordinary length. With longer spans more space should be provided, the spacing being approximately equal to the deflection of the wires. The spacings of pins next to the pole must

thoroughfares are used wherever possible for distributing lines. The narrowness of the roadway is such that the poles must be set close to the property lines, but the presence of buildings also makes it necessary to keep the cross-arms from overhanging the property. This necessitates the use of side-arms, or alley-arms as they are more commonly known, as shown in Fig. 3. The unbalanced strain on the pole caused by such construction is not serious, and is readily compensated for by setting the pole with a slight rake toward the property line. The weight of the equipment of cross-arms and wires then brings the pole up straight.

Pins of wood are preferred for distribution work on account of their strength, durability, low cost and in-

insulating qualities. Locust, elm, oak and other similar woods are common, but locust is superior to all in its strength and durability. Tests made on pins of the sizes shown in Fig. 4 gave an ultimate breaking strength of about 1200 lb. for oak, 1400 for elm and 1600 lb. for locust. These figures represent the pull in pounds applied

laid in the groove and twisted around the line wire several times at each side of the insulator. The point of support is relatively low and the side strain on the pin is therefore reduced to a minimum. The double petticoat is ample protection from leakage of electricity during stormy weather.

The glass insulator is usually less

insulator is more reliable, and therefore preferable even though more expensive. The type shown in Fig. 6 is generally used for 6600 volts, that in Fig. 7 being used for 10,000 to 15,000 volts.

Before the pole is erected there should be notches called gains cut about one inch deep in the pole to give a flat surface to which the cross-arms may be secured. The arms are fastened to the pole by bolts or lag screws. The use of bolts is preferable in the long run, as the fastening of the arm becomes insecure in the course of time, due to decay of the pole around the screw. When a bolt is used it is fitted with a nut and washer on both ends to give a firm and durable seat for the nut. The bolt should be  $\frac{5}{8}$  inch in diameter and from 12 to 16 in. long, depending upon the size of pole. The side of the pole on which the cross-arm is attached is generally known as the face of the pole, the opposite side being the back of the pole. Where lag screws are used the arms should be attached to the poles of a line so that the poles will stand face to face and back to back in every alternate span. This will prevent the cross-arms being torn from the poles by the strain of the wires if all wires burn off. This is a wise precaution with bolts also, but not so important as with lag screws.

In order to hold the cross-arm firmly in a horizontal position when it is not evenly loaded, braces must be provided. These are usually of strap iron about  $\frac{1}{4} \times 1 \times 24$  in. to 30 in. long when used on center-arms. The brace is placed at an angle of 45 degrees with the pole and is attached by means of lag screws to the pole and by bolts through the cross-arms.

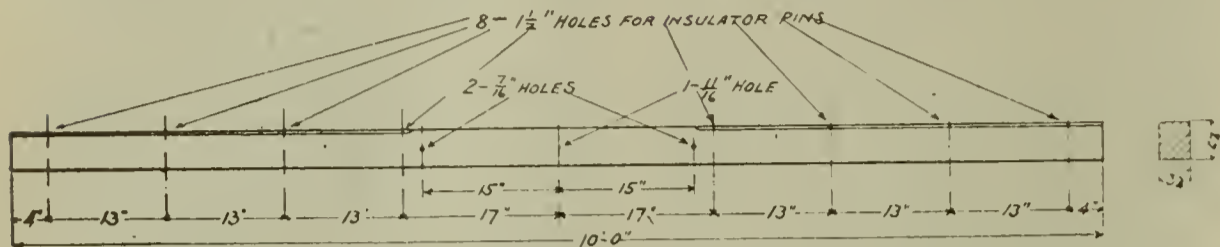

8 PIN JUNCTION ARM

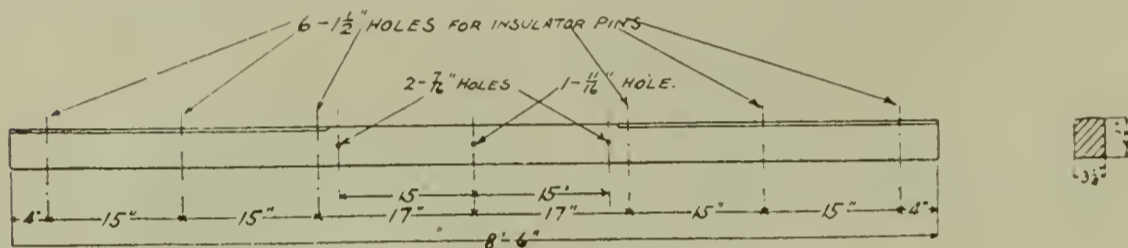

6 PIN JUNCTION ARM.

Fig. 2.

on a deep-groove, double-petticoat insulator mounted in its normal position on the pin, and therefore indicate the breaking strength of the pin under working conditions. A factor of safety of four to six is advisable, and care must be used in selecting pins free from knots and dry rot and having straight grain. Where wires of No. 0 and smaller are dead-ended or carried around a corner it is customary to distribute the strain between two pins by using double-arm construction. With heavier cables it is not desirable to attempt to support the strain by a pin, but it is usual in such cases to insert a strain insulator in the line near the pole and take the strain more directly on the guy cable.

Pins should be coated with white lead before being put into the pin holes and should then be secured by a six-penny galvanized nail. It is usually better economy to fill all pin holes with pins in the shop before the arms are sent out for use.

The most common type of insulator in American distribution practice is that known as the deep-groove, double-petticoat glass insulator shown in Fig. 5. The dimensions of this insulator are sufficient to carry circuits operating at potentials up to 5000 volts safely with standard wooden pin. The groove will carry any size of weather-proof wire up to 4/0. The line wire is secured to the insulator by a tie wire

expensive than porcelain insulators designed for the same class of service. The trouble experienced with breakage of glass insulators of the large type is not met with in the insulator in Fig. 5 because of its rugged design.

On overhead sections of transmission circuits which may operate at potentials above 5000 volts the porcelain

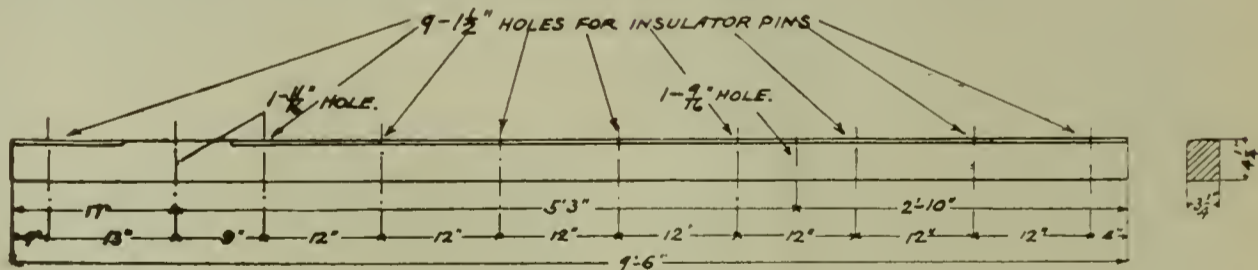

8 PIN ALLEY ARM.

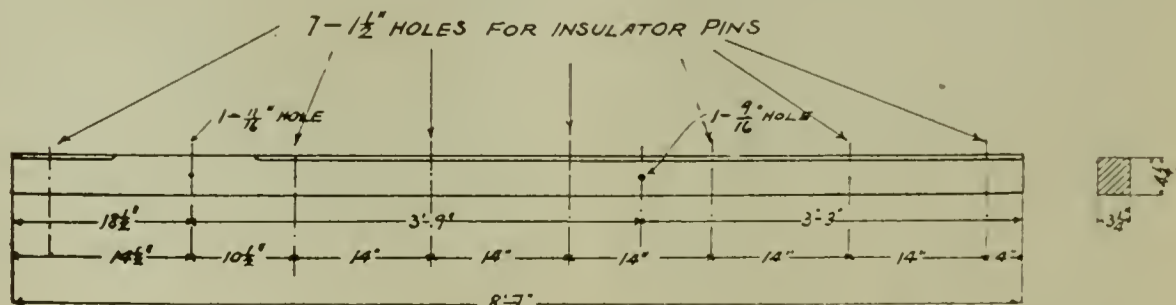

6 PIN ALLEY ARM.

Fig. 3.

Side-arms must be supported at a point farther out from the pole than center-arms, and it is therefore usual to use a brace of angle iron, such as that shown in Fig. 4. This is rigid

Where work is done on poles frequently the surface of the pole becomes badly cut up by the linemen's climbing-spurs, which is unsightly and in course of time weakens the pole. It is there-

In stringing wire it is usual to attach several wires to a rope by which a team of horses draws several spans of line over the cross-arms. When in place one end is secured and tension applied to the section of line by the use of block and tackle. With the tension applied linemen stationed at several points apply the tie-wires, thus securing the lines to the insulators. The remaining wires are similarly attached, care being taken to get the tension on all wires about the same. The tension varies with the size of the wire and with the deflection which is considered permissible. It should be

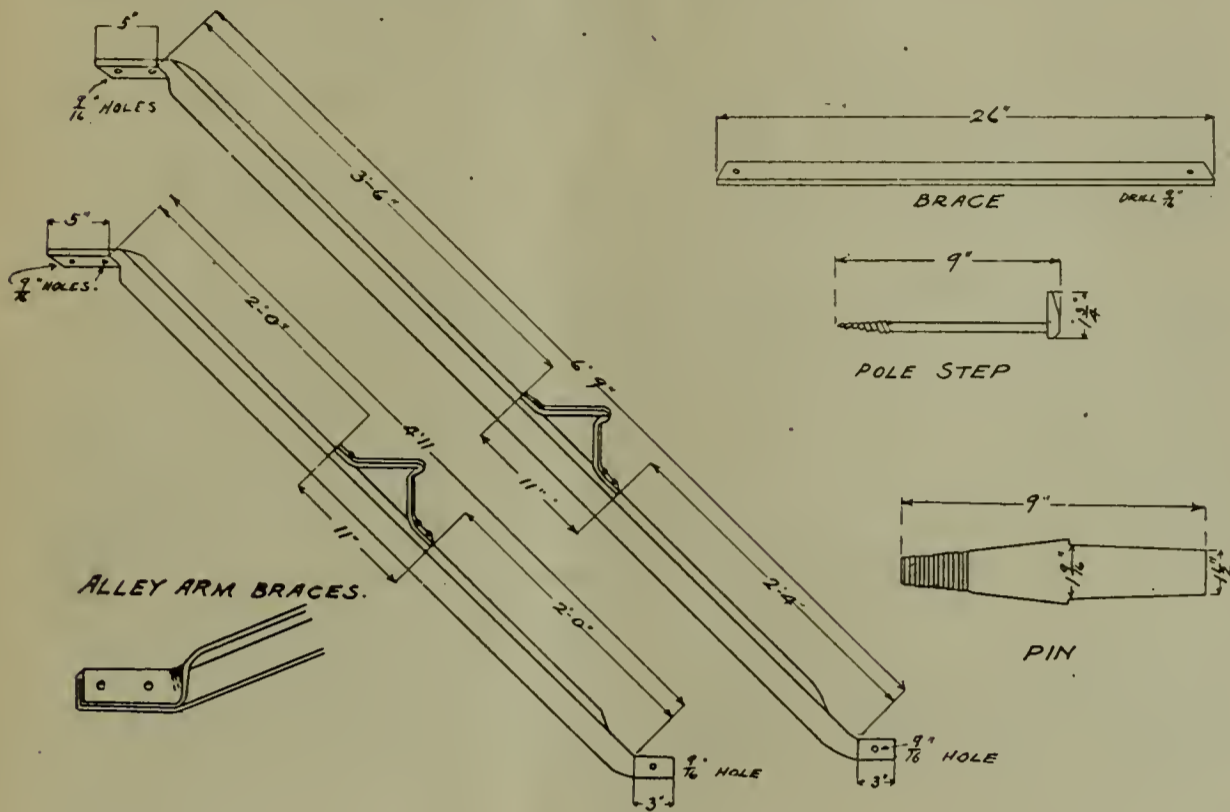

Fig. 4.



Fig. 7.

enough to bear the weight of a lineman on the step while working on wires at the outer end of the arm. This brace is used only on the lower arm where there are several arms on a pole.

The upper arms must be supported by braces of 1/4 x 1 x 24-in. strap iron, run vertically from the outer end of the angle-iron brace.

The spacing between gains must be sufficient to prevent wires carried on

fore desirable to equip all such poles with pole-steps such as those shown in Fig. 4. These are screwed or driven into the pole on opposite sides about three feet apart, beginning about eight feet above the ground, so that unauthorized persons will not be tempted to trespass.

The pole having been erected and equipped with its accessories is ready to have the wire strung. The size of wires will in general be determined by the conditions of load, distance, etc., but in overhead work the mechanical strength must be adequate, and it is therefore not safe to use wire smaller than No. 6 for primary lines. It is also common practice to extend this rule to low-tension lines, though No. 8

made sufficient to prevent too much sag in the spans and yet must not be so great as to unduly strain the wire and the guying equipment which supports it.

The theoretical curve formed by a wire supported under tension, as in pole work, is known as a catenary. The equation of this curve is based on the assumption that the wire is inextensible and perfectly flexible. This is, of course, not strictly true of insulated copper wire, and it is therefore found sufficiently accurate for all practical purposes to use the approximate formulæ of Rankine and others, which

$$\text{is as follows: } T = \frac{L^2 w}{8S} \text{ in which } T$$

is the wire tension in pounds, L is the length of the span in feet, w is the weight of one foot of conductor and insulation and S is the sag or deflection in feet.

To illustrate, assume a weather-proof wire of No. 6 carried on poles 100 ft. apart; with a sag of one foot, what is the tension on the wire? The weight of one foot of No. 6 wire being about 0.11 lb.,

$$T = \frac{100 \times 100 \times .112}{8 \times 1} = 140 \text{ lb.}$$

If the spans were 141 ft. the strain would be doubled, and at 200 ft. they would have to be quadrupled in order to keep the deflection one foot. If the tension is the same on several spans the deflection will be different in each

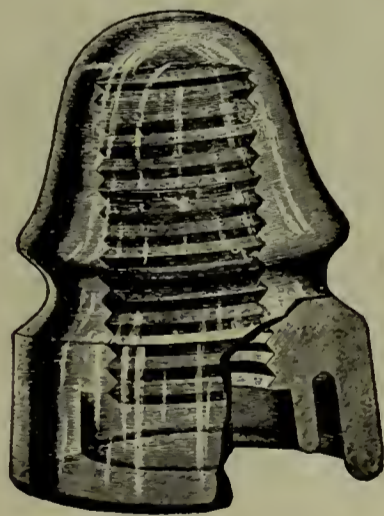

Fig. 5.

the upper arms from sagging on to those on the arm below and yet must be as little as possible in order to economize in the height of the poles. It is desirable to have from 20 to 24 in. between arms to facilitate the work of linemen, and as this is adequate for clearance purposes under normal conditions, it is usual to use a gain spacing of 22 to 24 in. between centers.



Fig. 6.

is sometimes used for short secondary lines. No. 8 and No. 10 are used for service drops to small consumers where the span from pole to building is 50 ft. or less.

span. In practical work this is usually the case, as the tension is usually the same throughout any straight section of line unless special provisions are made for guying certain spans of unusual length so as to increase the tension.

With a deflection of one foot in a 100-ft. span and a spacing of 14 in. between wires, there is very little danger of wires swinging together in a high wind, as they swing in synchronism. With a sag of more than two feet in a 141-ft. span, however, there is more danger of wires touching as they are loose enough to allow them to swing out of synchronism in a gusty wind. The deflection for any span when the tension is known is found by interchanging T and S in the foregoing formula so that it reads

$$S = \frac{(L)^2 w}{8T}$$

in a 141-ft. span under 1025 lb. tension

$$S = \frac{141 \times 141 \times .82}{8 \times 1025} = 2 \text{ ft.}$$

The tension in a line is fixed by the strength of the wire and its supports on the one hand and by the requirements of clearance on the other hand. The ultimate breaking strength of annealed copper wire is about 34,000 lb. per sq. in. The working strain should not be over one-fourth of this on the smaller sizes, as the swinging of wire in the wind tends to weaken it at its supports, and if pulled up too tight it stretches, increasing the sag and diminishing its cross section.

For No. 6 wire, which has an area of 0.0206 sq. in., the ultimate breaking strength is about 700 lb. The safe working strain is therefore about 175 lb., which gives a 14-in. sag in a 125-ft. span. The safe working strength of 4/0, which has an area of 0.1662 sq. in., is found in a similar way to be 1400 lb., which also gives about 15-in. sag in a 125-ft. span. With hard-drawn wire the ultimate tensile strength is about 60,000 lb. The surface of such wire is left in the hardened condition in which it comes from the wire-drawing dies, which gives it greater strength and stiffness. The wire, however, must not be scratched or kinked in handling, as any injury to the surface reduces the strength of the wire at that point to the strength of annealed wire. The same is, of course, true if it is heated for soldering. Hard-drawn wire is therefore not adapted for general distribution work where taps must be made with soldered connections at frequent intervals.

For transmission lines and series arc circuits it has advantages which are generally recognized and made use of. It is used for telephone work exclusively in order to permit the use of a small conductor with strength sufficient to support the tension of the span.

The tension at any deflection or the sag at any tension, or either sag or tension in any length of span, may be readily found from the accompanying table, as follows:

ANNEALED WEATHERPROOF WIRE, 100 FT. SPAN.

B. & S. G.....	10	8	6	4	2	1	0	2/0	3/0	4/0
T at 1 ft. sag.....	62	92	140	204	318	390	486	607	767	942
S at 100 lbs. tension.....	.62	.92	1.40	2.04	3.18	3.9	4.86	6.07	7.67	9.42
WT. wire per ft.....	50	74	112	163	254	312	388	486	614	754
Breaking Stress.....	283	440	700	1114	1772	2234	2818	3553	4480	5650

HARD DRAWN BARE WIRE, 100 FT. SPAN.

T at 1 ft. sag.....	39.3	62	99	157	161	212	470	505	636	800
S at 100 lbs. tension.....	.393	.62	.99	1.57	1.61	2.02	4.0	5.05	6.36	8.0
WT. wire per ft.....	31.4	50	79.5	126	201	253	320	403	508	640
Breaking Stress.....	500	778	1237	1967	3127	3943	4973	6271	7907	9971

The tension at any other deflection is

$$T' = \frac{T}{S}$$

in which S is the deflection in feet at which the tension is desired and T is the value in the above table in pounds.

For illustration, what is the tension in a 100-ft. of No. 0 weatherproof wire at a deflection of two feet?

$$T' = \frac{T}{S} = \frac{486}{2} = 243 \text{ lb.}$$

Similarly the sag at any other tension is  $S' = \frac{S \times 100}{T}$ , in which T is the

assumed tension and S is the value of sag at 100 lb. in the above table. With No. 0 weatherproof the sag at 600 lb. is

$$S' = \frac{S \times 100}{T} = \frac{4.84 \times 100}{600} = 8 \text{ ft.}$$

With spans of other lengths the sag or tension will vary in proportion to the square of the length of the assumed span in hundreds of feet. That is:  $S' = (L')^2 S$  and  $T' = (L')^2 T$ .

With No. 4/0 bare wire, for instance, the tension with a span of 150 ft. at one-foot sag would be  $T = (L')^2 T = 1.5 \times 1.5 \times 800 = 1800$  lb. Or if the tension of the line were uniform in all the spans, the sag in a 150-ft. span of bare No. 4/0 would be  $S' = (L')^2 S = 1.5 \times 1.5 \times 8 = 18$  ft. at 100 lb.

The foregoing table may be used in

the solution of practical problems as follows:

A line of No. 2 weatherproof wire is to be strung on poles with spans of 110, 150 and 200 ft. at various points. What deflection will result if the wire is pulled up to a tension of 300 lb. on all spans?

The sag at 300 lb. on a 100-ft. span

$$\text{is } S' = \frac{3.18 \times 100}{300} = 1.06 \text{ ft.}$$

On 110-ft. spans,  $S' = 1.1 \times 1.1 \times 1.06 = 1.28$  ft.

On 150-ft. spans,  $S' = 1.5 \times 1.5 \times 1.06 = 2.38$  ft.

On 200-ft. spans,  $S' = 2 \times 2 \times 1.06 = 4.24$  ft.

If 4.24 ft. is considered more deflection than is safe on a 200-ft. span, what tension must be used to reduce

$$\text{this to 2.5 ft.? } T' = 300 \times \frac{4.24}{2.5} = 510 \text{ lb.}$$

The changes in the sag of lines due to the expansion and contraction of the wires under varying temperatures are of much importance in the erection of the conductors. Lines erected during the summer months are found drawn very tight during the winter months, while those erected during winter months are apt to be too slack during the summer. Allowance should therefore be made for the temperature at the time the work is done.

The length of the wire in any span is known by the approximate formula:

$$W = L + \frac{8(S)^2}{3L}$$

in which L is the length of span in feet, and S is the sag in feet. With a 100-ft. span of 1-ft. sag,

$$W = 100 \times \frac{8 \times 1}{3 \times 100} = 100.0266 \text{ ft.}$$

That is, the wire is 0.266 ft., or 0.32 in. longer than the span. Likewise, if

the length of wire is known the sag is

$$S = \sqrt{\frac{3L(W-L)}{8}}$$

For instance, if a wire should slip on the insulator so as to add 0.48 in., or 0.04 ft., to the length of wire in the above span, the sag would be increased to  $S =$

$$\sqrt{\frac{3 \times 100}{8} (100.0666 - 100)} = 1.88$$

ft., or 19 in. The same condition would result if the pole were pulled over so as to shorten the span 0.48 in.

The length of wire in a span varies in proportion to the coefficient of expansion and the range of temperature.  $W' = W(1 + at)$ , in which  $a$  is the coefficient of expansion,  $t$  is the range of temperature in degrees Fahrenheit, and  $W$  is the length of wire at the lower temperature. When the length of wire at the higher temperature is known and the contraction is to be computed instead of the expansion,

the formula is  $W = \frac{W'}{1 + at}$ , in which

$W'$  is the known length at the higher temperature.

The coefficient of copper, in the form of wire, is found to be less than that of copper in other forms. Experiments made by stringing wire between fixed supports and observing deflections at different temperatures, indicate that the usual coefficient of expansion of 0.000095 which applies to copper in other forms is reduced to about 0.000040 to 0.000045 in the case of copper wire. This is borne out by practical experience, as variations of sag are not as great as those determined by calculations based on a coefficient of 0.000095. For example, with a 100-ft. span, strung when the temperature was 10° F., with 0.75 ft. sag, the sag at a temperature of 90° F. would be found as follows:

The length of wire in the 100-ft. span at 10° F. is

$$W = 100 + \frac{8 \times 7.5 \times 7.5}{3 \times 100} = 100.015 \text{ ft.}$$

At a temperature rise of 80 degrees the length becomes  $W' = W(1 + at) = 100.015(1 + 0.000045 \times 80) = 100.375$  ft. The increase in length of the wire is therefore 0.36 ft., or 4.32 in., and the sag is

$$S = \frac{3 \times 100(100.375 - 100)}{8} = 3.75 \text{ ft.}$$

This condition would be found if all supports were rigid and the conductor inelastic. In practice it is usually the case, however, that the pole supports have a degree of flexibility and resili-

ence which tends to take up part of the slack caused by expansion and to prevent excessive strains being placed on the wire by contraction during cold weather.

It is, however, very apparent from this example that severe strains are likely to result on the longer lines which run some distance without a change of direction, if some allowance is not made for expansion and contraction when the wire is strung.

The following table represents conservative practice in wire stringing at various temperatures, the deflection being given in inches for convenience:

Span Ft	DEGREES FAHRENHEIT.								
	20°	30°	40°	50°	60°	70°	80°	90°	
90	7	9	11	13	14	16	18	20	
100	9	11	13	15	17	19	21	22	
110	11	13	16	18	20	23	25	26	
125	13	16	19	22	25	28	30	32	
140	15	20	23	27	30	35	39	42	
150	18	22	26	30	34	40	44	48	

These figures are based on the supposition of supports which have some elasticity at the extremes of temperature, and with a factor of safety of about 4 at the lower temperatures. This may be lowered somewhat by strains at temperatures lower than 0° F., but experience has shown that dis-

kept approximately 100 ft. in making a crossing over a high structure, it is customary to rise in steps of about five feet in each successive pole if there are a considerable number of wires in the line. If the line is small it is permissible to rise and fall by intervals of 10 ft. in successive spans. The number of high poles required is, of course, smaller in the latter case, and this plan is preferable except where the importance of the line justifies the more expensive construction.

Where primary lines must be carried through trees, care must be taken to provide clearance from limbs as fully as possible. If the necessary permission can be gotten for judicious trimming it should be done. When the trees are very large it is usually preferable to carry the wires through the larger limbs below the main body of leaves. In this case insulators may be attached to the limbs or to the wires to prevent abrasion of the wire and burning of the limbs. Where trimming is not permissible to a sufficient extent to be effective, it is desirable to use wire having about  $\frac{3}{32}$ -in. rubber insulation covered with a layer of tape and two braids.

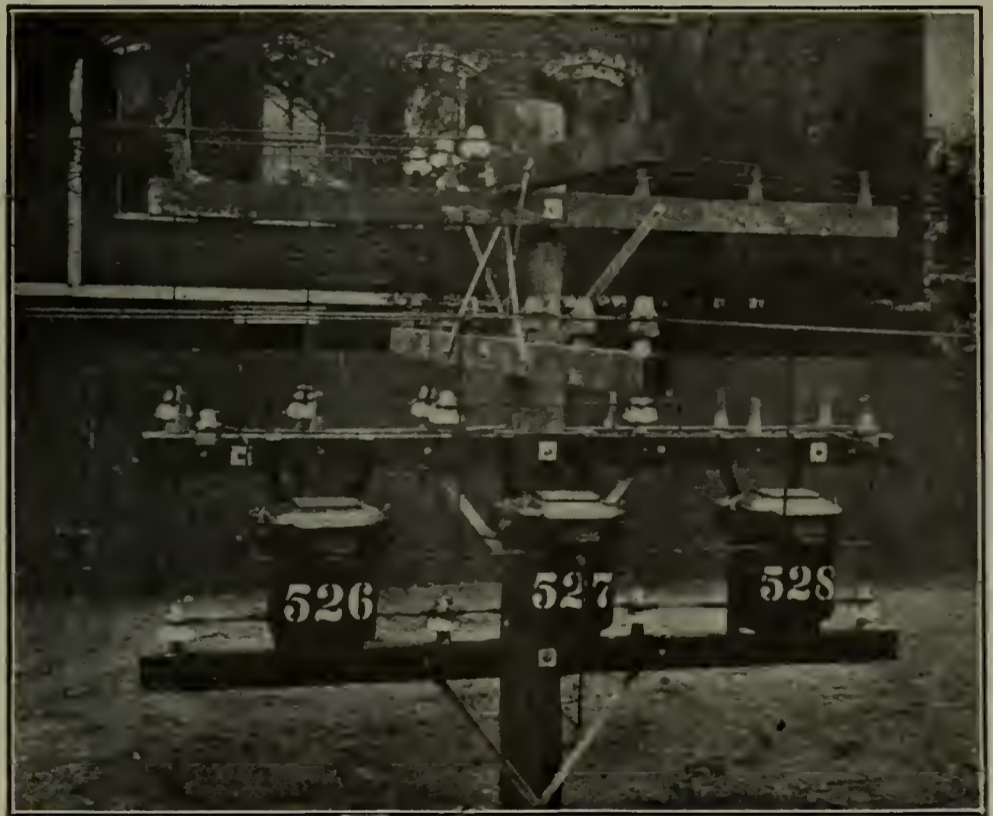

Fig. 8.

tribution lines erected on the basis of the above table are not subject to excessive breakage during severe cold weather.

In stringing wire across hilly country or in passing over elevated structures in city work, the change in level should be made so that the tension in the line will be the same throughout, if possible. This will be the case if the level of the wire follows the natural curve of a free span as nearly as possible. In city work, where spans are

With the stringing and tying in of the wire, the work of building the line is usually complete in the case of a transmission line, but such is not the case with distributing circuits. There are yet transformers to be hung, service-drops to be run to consumers' premises and often arc or incandescent street lamps to be hung.

Transformers are commonly supported on cross-arms by iron hangers furnished by the manufacturers. A typical installation of a small unit is

shown in Fig. 8. This class of construction is suitable for transformers of capacities up to 20 kw. With larger units the cross-arms should be double at the top, as they carry most of the weight. One method of making an installation where side-arm construction is used is shown in Fig. 9. A seven-foot arm brace is used in this case to give room for the larger units.

In making transformer installations for three-phase service the smaller capacities may be hung as in lighting work. Where two or three transformers of over 25-kw. capacity are required the double-arm construction is advisable. Where the installation consist of two 20-kw. or three 15-kw. transformers or larger, it is advisable to use a larger sized cross-arm than the standard. An arm having a cross-section of 4 by 5½ in. has been found ample for installations aggregating 90 to 100 kw. Such an installation is illustrated in Fig. 10.

Where very large power is to be served which requires a number of 50-kw. units which cannot well be put inside the building, they may be safely and conveniently installed on a platform between two or more poles, as shown in Fig. 11. The use of units larger than 50 kw. is usually not convenient, as the weight is difficult to handle and the work of replacement is more expeditious in case of burn-out. The platform in Fig. 11 is supported by timbers 3 by 10 in., bolted to the poles, and the platform is of 2-in. plank. The platform is wide enough to give access on both primary and secondary sides of the units.

To guard against damage to life or property in case a primary wire becomes crossed with a secondary at any point, it is very desirable that the secondary be grounded as securely as possible. This should be done by connecting to water pipes in customers' premises wherever these are accessible to the service entrance. The connection should be made on the line side of the service switch so that it will not be disconnected at any time. Where the ground cannot be reached in the customer's premises, the most practicable method is usually to drive a ½-in. galvanized iron pipe into the ground about eight feet at the base of a pole near the transformer. If there are more than four spans of secondary grounds should be installed for every 500 ft. of secondary line.

On a two-wire 110-volt secondary the ground is connected to one side, but with a three-wire Edison secondary the neutral wire is grounded, making a potential of 110 volts from either outside wire to ground. On a 220-volt single-phase power secondary the neutral point of the transformer winding should be grounded. With a two-

phase four-wire power secondary the mid-point of each transformer winding should be grounded unless the motor windings served are interconnected so as to prevent it. In that event the neutral of one transformer should be grounded, and the same procedure should be followed with a three-wire two-phase secondary.

With a star-connected 200-volt or 400-volt three-phase secondary the neutral point of the system should be grounded, giving 115 or 230 volts to ground respectively from each phase wire.

With delta-connected 220-volt sys-

through a water pipe the wire should be attached by means of a copper clamp or other connection which may be securely attached to the pipe and wire.

When the connection is made to a pipe at the pole the ground wire of No. 4 wire is preferably brought down the pole in a half-round wooden moulding, to protect the linemen and the public from accidental contact. The ground wire may be soldered to the pipe about a foot above the ground; or may be attached by means of a pipe cap as shown in Fig. 12. This cap may be used to drive the ground pipe and

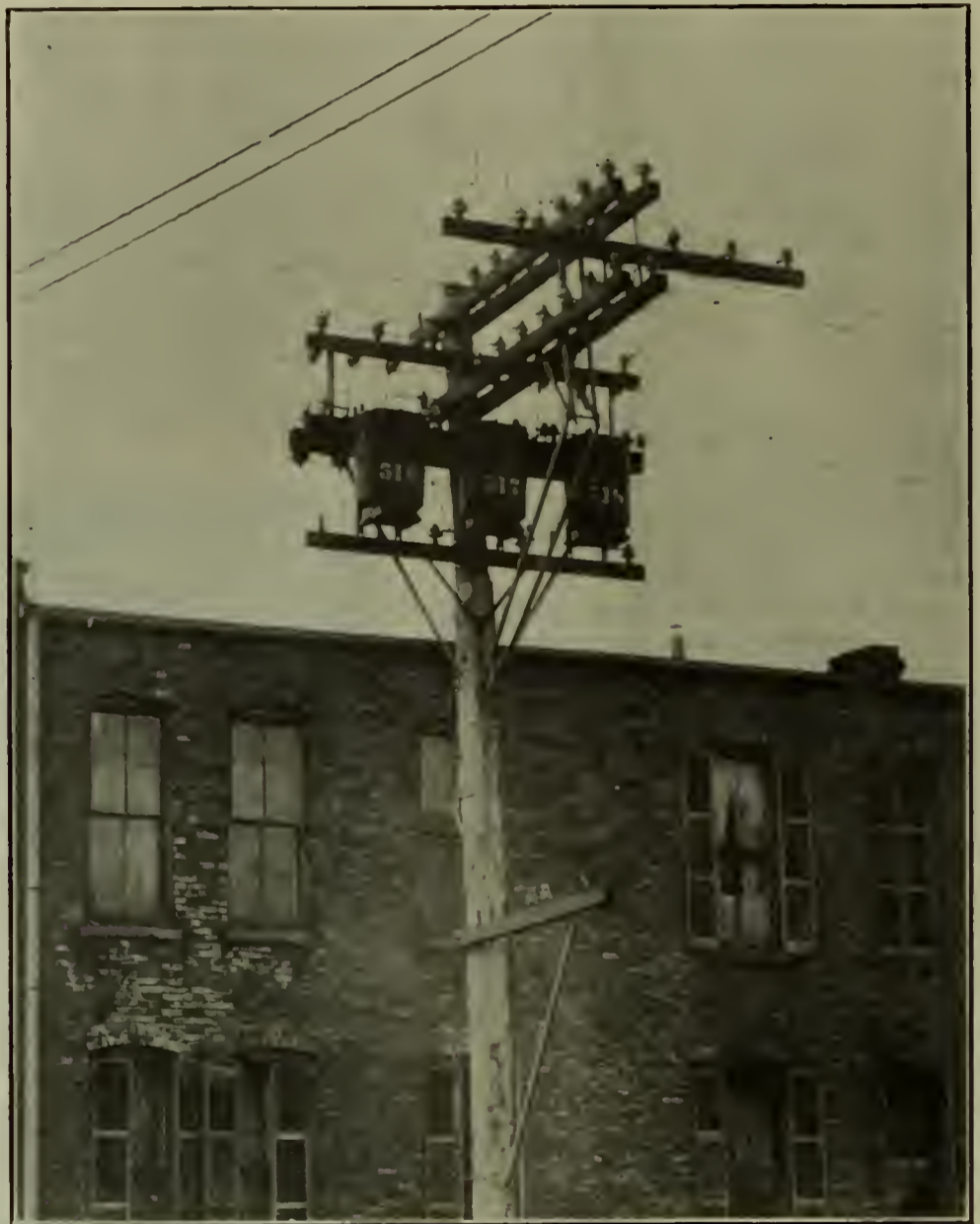

Fig. 9.

tem the ground connection should be made to the mid-point of the winding of one transformer. This gives 110 volts to ground from the two-phase wires next to the ground wire and about 200 volts from the other phase to ground. There is some doubt as to the advisability of grounding a secondary when the difference of potential between any wire and ground will be higher than 250 volts, owing to the possibility that shocks from such a system may prove fatal under favorable circumstances.

When connection is made to ground

at the same time produce a driven contact between wire and pipe. The pipe is usually driven to the ground line with this cap in order to minimize the amount of exposed surface.

In rocky country it is sometimes necessary to run a ground wire throughout the denser points of the system and connect it at one point to a well-made ground. This is, of course, an expensive method and it not used except as a last resort.

Service drops should be tapped near the secondary-line insulators and supported by them when they can be car-





Fig. 10.

ried at such an angle from the pole that they will clear properly. Where they leave the pole at approximately right angles they may be supported from the end pins of two or three arms if they are available or by a break-arm or by a buck-arm. If there are several services taken from the same pole the use of a buck-arm is the best method usually as services can be taken to both sides of the thoroughfare in any desired number from one buck-arm.

Where separate power and light services are maintained, the use of a six-pin buck-arm provides facilities for both classes of service. The attachment of service wires to buildings is one of the most troublesome details of distribution work, owing to the varying character of buildings, lengths of drops and angle of approach. With frame buildings wooden brackets and spikes are fairly satisfactory for wires up to No. 0 and spans up to 60 or 75 ft. With brick or stone buildings, however, this construction is not reliable. Where three-wire service is required, the necessity of drilling bolt holes for each wire, where brackets are used, has led to the development of various forms of iron brackets.

In making a loop on series arc circuits, the break-arm is usually employed.

Arc lamps for street lighting are

supported by a crane from a pole or from a messenger cable strung between two poles and equipped with a pulley by which the lamp can be lowered for trimming purposes. The latter method is the least expensive usually, and is used except where the use of two poles is not practicable or is considered unsightly. In the larger cities it is usual to mount lamps on a short bracket without provision for lowering the lamp. In this case the pole is stepped so that the trimmer climbs the pole to trim the lamp.

The position of wires on the cross-arms should be selected according to a systematic plan. Circuits should be kept on the same side of the pole and on the same pins throughout their course, to facilitate location of trouble and to eliminate the possibility of accidents to workmen or property due to misunderstandings. In general, through lines and the highest voltages should be carried on the upper arms. Distributing mains and arc circuits supplying lamps in the vicinity should be carried near the bottom of the line. Secondaries should be carried on the lowest arm to facilitate service work.

The lowest voltages should be carried on the pole pins. Where side-arms are used the primary wires should be carried at the outer end of the arm. The wires of any circuit should be carried on adjacent pins and the neutral

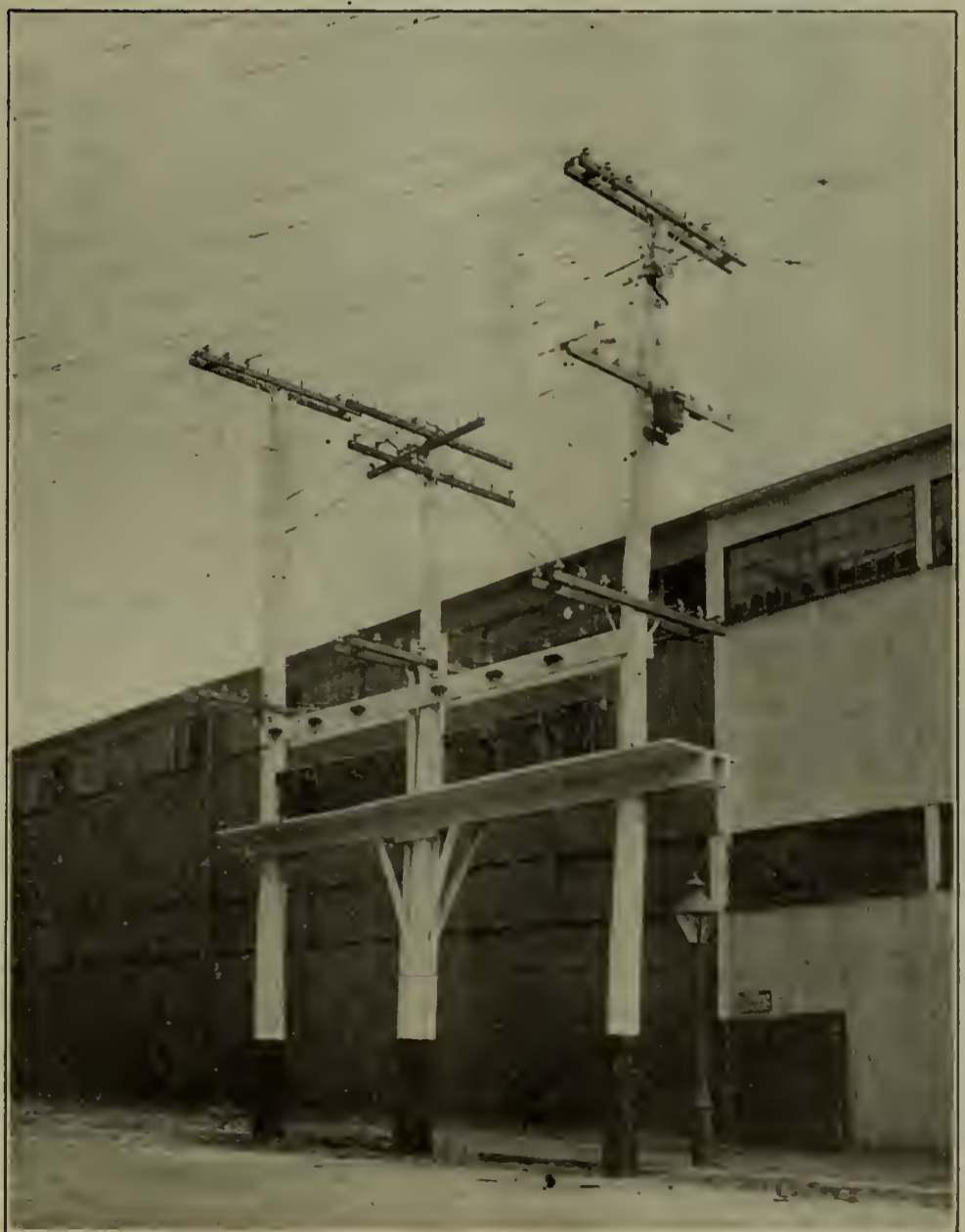

Fig. 11.

of low tension or secondary wires should be carried in the middle. On four-wire three-phase lines the neutral should be carried at one side of the phase wires and on one of the pole pins of a six-pin or eight-pin arm. With side-arms it should be carried on the side of the circuit nearest the pole. In carrying connections across the pole for transformers or services one side of the pole should be left free for climbing.

Where poles are occupied jointly by electric light and telephone or telegraph companies, the lighting wires should always occupy the upper part of the pole, as the signaling wires are more likely to break than the lighting lines.

A clearance of about five feet should be maintained between the lower lighting wires and the upper signaling wires. This may be reduced to three and one-half feet between the bottom of a transformer and the upper signaling wires. These clearances are neces-

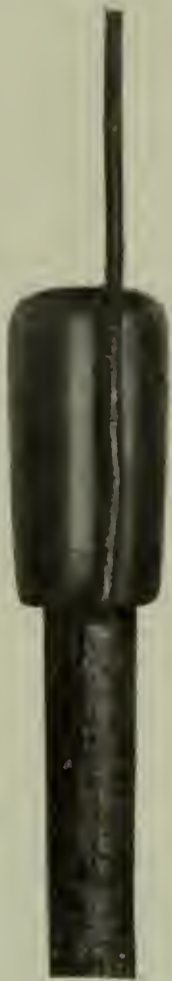

Fig. 12.

sary for the safety of linemen who may be working on either set of wires.

The use of a joint line of poles is preferable to separate lines on thoroughfares where there are many service drops. With lines on opposite sides of the street, the service drops of the lighting company must pass under or through the lines of the signaling company on the other side, and *vice versa*. This introduces many dangerous situations which are eliminated when all drops are taken from one set of poles.

It is usually very undesirable to

erect a separate line of poles on the same side of the street with an existing line.

With alley lines the use of joint poles is the safest method, unless the lighting line is carried high enough to permit all service wires to be carried above the signaling line. This involves extra expense and is objectionable on that account.

The joint occupancy of pole lines requires close co-operation between the employes of both companies and a spirit of fairness between the managers who agree upon the working conditions.

### Impregnating Compounds

BY J. R. SANBORN.

IT is becoming an almost universal custom to impregnate field and transformer coils with a solid impregnating compound. For this impregnating compound there are two principal requirements:

(1) The melting point must be high enough to stand the running temperature of the apparatus, and low enough to remain thoroughly melted at a convenient temperature in the impregnating tanks.

(2) The penetrative power of the material must be as good as can be obtained.

In practice the gum is kept continually melted in a large tank, which tends to raise the melting point and decrease penetrative power.

In order to determine quickly these two characteristics, the following methods have been developed.

#### MELTING POINT.

The melting point is arbitrarily defined as the temperature at which the first drop of gum falls from the bulb of a thermometer, the gum being molded on the thermometer bulb and thermometer and gum heated at a constant rate. It has been found by test that the melting point thus obtained must be taken under absolutely uniform conditions in order to get consistent results. We believe the best practice is to use a chemical thermometer with a stem not greater than  $\frac{1}{4}$  inch in diameter. Mold on this thermometer a ball of the impregnating compound  $\frac{3}{16}$  inch in diameter, previously heating the thermometer slightly. The gum should cover  $\frac{1}{2}$  inch of the thermometer bulb. Suspend the thermometer in a 20 mm. test tube and place the test tube in a 100 cc. flask, the bottom of the test tube coming to just  $\frac{1}{2}$  inch from the bottom of the flask. Fill the flask to the bottom of the neck with glycerine. The top of the gum as molded on the thermometer should be just on a level with the top of the glycerine. Heat the apparatus uniformly at the rate of

$5^{\circ}$  C. per minute. The gum will soften and a drop will eventually detach itself and fall. The temperature of the thermometer at the time when this occurs should be taken as the melting point.

#### PENETRATIVE POWER.

A quick test for penetrative power is the time required to penetrate a single layer of filter paper, preferably of medium grade, the filter paper being held below the surface of the melted compound. The time taken is that required for the first particle of the gum to penetrate completely the filter paper, that is to say, when the first particle of gum actually appears through the paper—as indicated by the color of the paper turning from gray to black. For best results we recommend that the paper be stretched tightly across the end of a thin-walled metal cylinder one inch in diameter. The gum should be heated uniformly throughout to a fixed temperature, the scum pushed back from the surface, and the filter paper quickly plunged to a depth of one inch below the surface. The inner surface of the filter paper may be viewed through the cylinder. The moment when the first particle of gum appears on the inner surface of the filter paper is known as the time of penetration.

#### A New Business Problem

Boston, Mass., Sept. 18, 1908.

The point recently came up in regard to the practice in making allowances for fast meters when a customer was charged a differential rate of any sort.

The most common differential rate, of course, is a wholesale discount; say, no discount on \$10.00, but a discount of 10 per cent. when the bill exceeds \$10.00.

Suppose the meter showed \$12.00 worth list, which would, after the discount be \$10.80 and then an error of 50 per cent. was found in the meter. Would this 50 per cent. be computed on the net bill as sent to the customer, making it \$5.40, or would the error on the meter be computed on the number of units supplied, and then the bill recalculated, which in this case would make the bill \$6.00?

The practice of the Boston Edison Company is to recalculate the bill according to the number of units that were actually supplied.

Of course, when a Wright Demand, or other method is used, say 15 cents for the first hour's use and 5 cents for additional use, then the difference between computing the meter error on the net bill or of computing the meter error on the units sold and then refiguring the bill would be much greater.

# Switchboard Notes

By S. Q. HAYES

Member A. I. E. E.

THE ideas embodied in this paper are some of the more interesting features that have come up recently in connection with large switchboard projects requiring distant control for the oil circuit breakers, etc.

## SWITCHBOARDS.

While panel boards or pedestals and posts are frequently used in large stations, control desks or bench boards are usually employed where compactness is essential. The more recent control desks are provided with an instrument frame back of and above the control desk, so arranged that the operator can face the generator-room and look over the top of the desk and under the frame to watch the machines he is controlling. These desks are made either straight or curved, depending on their length.

## FEEDER CIRCUITS.

Where the number of feeders is small, they are often controlled from the generator desk, but if they are numerous it is customary to furnish feeder panels often arranged as an arc of a circle with the generator desk forming a chord. The feeder switchboard is sometimes made double with two rows of panels back to back. The front panels on the concave side have the indicating meters, controllers, etc., while the relays, recording meters, calibrating switches, etc., are mounted on the rear panels, which form the convex side. This type of feeder board is self-supporting, and as none of the fine wiring on the back of the panels is visible without passing in between the panels, a very fine appearance is presented.

## INDICATING LAMPS.

As a rule, indicating lamps with red and green lenses are mounted on the control desk or feeder panels to show the operation of the breakers. Where the connections are complicated, it is customary to place a miniature bus on the switchboard and to locate the indicating lamps in this bus in such a manner as to clearly indicate the connections that have been made.

## SYNCHRONIZING RECEPTACLES.

Synchronizing receptacles are also located in this bus in such a manner as to clearly indicate what circuits are being synchronized, and these recep-

tacles are provided with extra contacts, so wired that it is necessary to insert the synchronizing plug in its receptacle before the breaker can be closed that will connect together any circuits that should be synchronized. While the closing circuit of a breaker passes through the extra contacts of the synchronizing receptacles the tripping circuit does not, so that a breaker may be opened independent of the position of the synchronizing plug. To make this synchronizing absolutely fool-proof an automatic synchronizer can be used.

## TESTING RECEPTACLES.

Most of the later switchboards are provided with small knife switches, or jack receptacles, to permit testing meters to be cut into the circuits from the series and shunt transformers, so that the switchboard meters can be calibrated in position without removing them from the panels.

## MIMIC DISCONNECTING SWITCHES.

Where some of the main connections of a plant are made by means of knife switches, mimic switches have been placed in the miniature bus and there arrangements are modified to correspond with the changes made by the knife switches. A recent improvement is to use telephone lamps in place of the mimic switches, and to connect these in series with standard lamps and snap switches located in the high-tension room near the disconnecting switches. The station attendant, after opening or closing the disconnecting switches, turns the snap switch on or off to light up or extinguish the telephone lamps on the desk. Failure of the lamp will indicate the danger position.

## SIGNAL LAMPS NEAR DISCONNECTING SWITCHES.

In some cases the disconnecting switches are so located that it is difficult to see whether the oil circuit breaker they isolate is closed or not. To guard against the trouble that would result from pulling a knife switch under load in some plants, red and green signal lamps are placed near the disconnecting switches, and these, as well as the indicating lamps at the switchboard, are controlled by the mechanically operated signal switch located on the oil circuit breaker to show whether the breaker is open or closed.

## EXTRA SIGNAL SWITCHES ON BREAKERS.

In addition to the usual double throw mechanically operated signal switch on the breaker, additional switches are sometimes provided for electrically interlocking various breakers and for taking care of leads from shunt transformers to the pressure coils of wattmeters, etc., on feeder circuits that would otherwise have to be provided with separate shunt transformers. By the use of this scheme, it is often feasible to avoid furnishing shunt transformers for high-tension circuits that have to be synchronized.

## WATTMETERS FOR HIGH-TENSION TRANSFORMERS.

It is sometimes necessary to keep an accurate record of power on the high-tension side of a transformer circuit and to avoid the use of high-tension instrument transformers, the series and shunt transformers can be located on the low-tension side, and compensators furnished to allow for the ohmic and inductive drop in the transformers.

## DISCONNECTING SWITCHES FOR BREAKERS.

In addition to the mechanically operated signal switches, hand operated knife switches are sometimes placed on an oil circuit breaker for cutting off the operating circuit. Where this scheme is used and the disconnecting switches are mounted in the same masonry structure, as the breaker they isolate, or are located above them in plain view, it is absolutely safe for an attendant to work on a breaker without fear that some other man will close the knife switches or attempt to operate the breaker.

## WIRE GLASS DOORS FOR COMPARTMENTS.

The doors of circuit breaker structures, as well as the compartments for disconnecting switches, fuses, etc., are often provided with clear glass panes that permit an inspection of the condition and position of the apparatus without opening the doors.

## CONTROL OF HYDRAULIC APPARATUS.

Some large hydro-electric installations have motor-operated penstock valves and motor-operated turbine governors, so that the switchboard operator can start, regulate and stop the waterwheels, as well as to connect, disconnect and adjust the generator, exciter, transformer and feeder circuits.

## ARRANGEMENT RECENT PLANT.

In one large plant, now being designed, the control desk will be located in the distributing station at the top of the hill, and the control of the waterwheels, generators, etc., in the generating station at the foot of the cliff will be in the hands of the switchboard attendant.

## EMERGENCY CONTROL.

In the generating station will be placed an emergency desk with a controller for each machine so arranged that when turned to the trip position all of the breakers in the armature and field circuits will be opened, and the governor motor will be started to reduce the speed of the waterwheel. When the governor reaches the limit of its travel, a switch connects in the operating circuit of the valve motor and when the valve is closed its limit switch cuts off the operating circuit.

## INTERLOCKING OF EMERGENCY AND MAIN CONTROL.

As the circuits used for operating the valve motor to turn water into the penstock, as well as the closing circuits for the various feeders are brought to this emergency switch, it will be impossible for the switchboard operator in the distributing station to start a machine while the emergency switch in the generating station is in the open position. Turning this emergency switch back to its closed position will not have any effect, as the controllers in the distributing station will be in the off position. With this arrangement the operator in the generating station can shut down a machine and prevent its being started, but leaves the starting of the machine entirely in the hands of the Chief Operator in the distributing station.

### Evolution of the Return Circuit Department

BY MARK T. STANTON,

Superintendent of Underground Cables and Return Circuits, Rochester Railway Company.

**T**HE return circuit, once a much neglected portion of an electric traction system, nowadays receives attention more in proportion to its importance than ever before. The amount of work required for the proper maintenance of the return circuit has become so great that many traction systems have deemed it advisable to organize a return circuit department.

In the early days the importance of the return was not fully appreciated and what little crude work was done was naturally left in the hands of the track department. Afterwhile the electrical engineer began to realize that the losses in the return circuit

were considerable and improvements were made in the methods of bonding. The old method of riveting through a loop in its end a piece of copper wire to the rail was a good mechanical job and would have sufficed for the track department, but the electrical department recognized the fact that something must be done to improve the contact between wire and rail.

The result has been the development of various methods, such as drift pins, compressing solid copper terminals into holes in the rail, soldered bonds, brazed bonds, etc. Any bond, however good in design and in its method of installation, is poor if the work of placing it is not properly done. This requires that the electrical features should receive as much consideration as the mechanical ones.

The mind of the track department is trained on mechanical lines and it has seemed in some cases to be almost impossible to get the track gangs to wake up to a full appreciation of the electrical features of a rail bond and what its functions are. Dirty bond holes and bonds, rough and irregular bond holes, insufficient pressure on compressed terminals, drift pins driven crookedly, unclean rail and insufficient heat in the case of soldered bonds, etc., might not interfere in making a fair mechanical joint, but are fatal to an electrical joint.

In order to insure that the bonds would be installed so as to have a high electrical efficiency, the electrical engineer was obliged to have his inspector present when any track work was being done. Later he found it advisable not only to send out an inspector but also men from his department to do the actual labor of installing bonds at points where the track gangs were at work or where any defective bonds were to be replaced.

Aside from the many details of the bonds themselves, the question of electric surveys, cable returns, etc., require considerable time and work in order to effect the return to the power house with as little loss and electrolytic damage as possible.

The work of testing bonded joints, keeping records of same, noting efficiency and life of various types of bonds—all can be attended by a properly organized return circuit department, much better than by having this work distributed among the various other departments.

It might be interesting to know some of the results of the records kept of tests made of bonded joints and some of the improvements which have been made in them.

We use the Conant bond tester, which gives the resistance of three feet of joint and rail in terms of

length of continuous rail. We rebond all joints that show a resistance greater than five feet of the adjacent rail. Test made on 70 lb. T rail, bonded with one 4/0—10½ in. by ⅞ in. compressed terminal bonds, which were installed by the track gang without an inspector present, gave the following results:

Of 2991 joints tested, 898, or 30 per cent. of them, showed a resistance equivalent to six feet and over of adjacent rail. Removing some of these bonds we found the terminals of bond and hole in rail badly corroded. Other tests, made on 95 lb. girder rail, with one 4/0—42 in.—1 in. pin terminal bonds that had been in three years, showed 38 per cent. of them testing six feet and over. Tests made lately of bonds installed three years ago under inspection of the return circuit department show them to be in much better condition than those installed without inspection.

Of joints with one 4/0—10½ in. by 1 in. compressed terminal bonds on 95 lb. rail only eight per cent. tested over six feet of rail. Joints of 95 lb. rail with one 4/0—42 in. by 1 in. pin terminal bonds that had been on three years gave 11 per cent. as testing over six feet of rail. This, of course, is not perfect, but it shows what can be accomplished by care in installing the bond.

One hundred and seventy-seven soldered bonds that were put on in 1905 as an experiment proved a failure. On inspecting them recently, we found these were all off and lying between the paving brick and rail. Part of these were put on by the manufacturer.

Twenty-four semi-plastic plug bonds that were put on last July on 95 lb. girder groove rail tested recently 3½ feet. They were put on the Clark joint without the Thermit weld on bottom of rail.

Of 98 joints bonded with one 4/0—10½—1 in. pin terminal bonds with amalgamated contacts that had been on 15 months, 91 show a resistance equal to 4½ ft.; seven, 6 ft., and one, 12 ft. of adjacent rail.

Our experience with the electric brazed bond proves it to be the best we have used. Bonds installed in 1904 are as good to-day as when first put on. Tests made recently on 70 lb. T rail with 1—8 in.—4/0 bonds that had been on for two years showed that of 1168 joints only 18 tested over six feet of adjacent rail, four of these having broken strands, 12 having one end off where wagons drove in track, and two having been imperfectly brazed.

Of another lot of 513 joints with one 8 in.—4/0 bond under Weber joints on 95 lb. girder rail, that had

been on for one year, 510 tested 4½ feet and three 6 feet of adjacent rail.

Tests made on 9236 electric welded joints that had been on one year showed 43 of them equivalent to over 6 ft. of rail, all defective joints being broken rails.

Thermit welds that we had been making all summer, starting in April and tested in December, have results as follows: Of 2864 joints, 250 tested over 6 ft. of rail and were mostly all broken rails.

We have no reliable record of cast welded joints, but such as we have

shows that they will run about the same as the Thermit.

A test recently made of the Clark joint, which is a combination of tight-fitting bolts and splice bars with a Thermit weld on bottom of rail, gives the most uniform resistance—2542 joints tested, all of them equivalent to three and one-half feet of adjacent rail. Some of these joints have been in two years, but the average is about one year.

We cross bond every 500 ft. within a radius of one and one-half miles of the power-house; beyond that every 1000 ft.

All special work and railroad crossings are jumpered with cable.

At the Cedar Avenue power-house the negative bus is outside the building, underground between curb and sidewalk, in conduit that runs full length of power-house with man-holes opposite each generator and a large vault under car tracks where connections from rails and underground and overhead cables are made to negative bus.

Drawings are kept on file showing all details pertaining to cross bonds, return cables and jumpers, giving location, size and method of connecting.

## Measurements with Portable Instruments

By F. P. COX\*

IN presenting this paper on measurements with portable instruments, it is not my purpose to introduce any new or unusual applications of such apparatus. I desire rather to discuss the measurements which are made in everyday central station practice, to comment on the conditions which influence such measurements, and particularly to call attention to certain errors which are liable to be introduced and which tend to limit the accuracy of measurements made under commercial conditions.

I wish to eliminate the equipment and results which might be obtained by establishing laboratories in the central station. Laboratory methods, laboratory instruments and laboratory accuracy have no part in the subject under discussion. That such a laboratory is of the greatest value to the central station is not questioned, but where it is found, it is fair to assume that experienced men are employed and that they have a proper appreciation of the natural limits of accuracy in the apparatus which they handle. Where portable instruments are used by laboratory men, I have no word of advice to offer. But when, as is often the case, they are placed in the hands of those who have not made a special study of such apparatus and who are unable to devote the time necessary to a full appreciation of its limitations, errors of startling magnitude may creep in. It is the object of this paper to call attention to some of these disturbing influences and to sound a warning against having greater faith in the results of a test than the limits of

instrument accuracy or test conditions would warrant.

Inaccuracies in reported values may be divided into two classes—those due to errors of the observer and those due to the errors of the instrument. Under the former must be included errors due to incorrect connections, which are by no means unusual in the measurement of polyphase circuits, errors due to not noting and allowing for zero errors in the instrument and errors due to parallax which may be avoided by properly using the image of the needle reflected from the mirror under the scale. Errors of this description can be corrected in only one way, and that is by dispensing with the men who persist in making them. Not everyone is capable of properly reading instruments, simple though the operation appears, and only employees who have shown their ability to appreciate the delicacy of instruments should be permitted to handle them at all.

The personal equation of an observer which causes one man to read the needle as above and another as below the true position, need not be taken into account in commercial measurements. When a needle is fluctuating through a considerable angle, it is sometimes difficult to estimate its true position. If the most dead beat instruments available are used, no further precautions are possible, except to take the average of a considerable number of readings. These readings should be jotted down as fast as they can be taken and no attempt made to obtain the average reading by estimating with the eye the mean position of the needle. Even with this pre-

caution, great reliance must not be placed on observations taken under unfavorable conditions. The results, at best, are approximate.

A fruitful source of error is the habit of reading instruments when the deflection is small. The average observer, using a reasonable amount of care, cannot be relied upon to estimate the position of a needle much closer than 1/100 of an inch, and at 1/5 scale the error introduced is five times the magnitude of a corresponding error at full scale. It is recommended that deflections of less than 20 per cent. of the full scale be classed as approximate. All instruments have errors due to temperature changes and are affected by local magnetic fields. The errors so introduced may be a very small fraction of a per cent. or they may amount to several per cent., depending upon the design and type of instrument. Local field errors may be noted and, if not too great, allowed for, by reversing the leads to the instrument or by turning it through 180 degrees. The mean value of the observations should be taken as the correct reading. It must be remembered that local fields are found, not only in the immediate vicinity of busses carrying large currents, but also some distance away where they have been carried by the iron framework of the switchboard or of the building. Sometimes an unshielded instrument is read when resting on the iron grating of a switchboard gallery or on a hand rail, and errors of considerable magnitude may result. Such errors cannot be corrected by reversing the position of the instrument or by reversing the leads, since they are due to the pres-

\* Association of Edison Illuminating Companies.

ence of a mass of iron in the vicinity of the instrument.

Scale errors due to incorrect marking are generally small, not amounting to over 2/10 of a per cent., and are most liable to be found in the subdivisions of the scale, since each subdivision is not an observed point. It is customary to observe and check the principal divisions, in some cases the half divisions, and to interpolate the intermediate ones.

Care of instruments, or rather, want of care, should be considered as a very important source of error. Shelves provided with a thick felt covering should be used for storing them. Such shelves are inexpensive and pay for themselves in reduced repair bills and improved accuracy. The instruments should be in charge of one competent man who will examine their condition when they are returned to his stock. He should see that they are compared with suitable standards once or twice a month and frequently cross checked. He will soon determine which employees are treating the instruments properly and which are abusing them. Such abuse may consist in careless handling in use or in transportation. In riding in street cars the careful instrument man will keep his instruments in his lap or on the cushioned seat. The careless man will drop them on the floor. In sending instruments out by wagon, felt-lined boxes should be provided to protect them in transit. It is well to purchase instruments of high torque and robust construction, but it should be remembered that the term "robust" is only comparative. Instruments should be given the same care which is given to a valuable watch, and no matter how strong the instrument may be, it will not be improved by rough handling.

The measurements which are most commonly made by lighting or power companies are of Potential, Current, Energy and Time. Perhaps the latter might seem rather beyond the scope of this paper, but it is an important factor in the calibration of meters and it seems advisable to make some mention of probable errors in this measurement.

#### POTENTIAL.

In considering the subject of errors in measurement of Potential, it is necessary to divide this subject into two types of circuits, continuous and alternating currents. It is well recognized that the best type of instrument for measuring continuous current circuits is the D'Arsonval. For economy of energy absorbed and dead beat qualities, this instrument is a most satisfactory one. The best instruments of this type have a resist-

ance of about 100 ohms per volt of scale reading. The errors introduced by temperature changes are insignificant, except in those multiple scale instruments which have a tap of one and one-half or two volts full scale reading. Where this tap is used, the accuracy of the low reading scale should be regarded with suspicion, since it is liable to have a temperature error of about 1/10 of one per cent per degree C. This type of instrument when provided with an iron case is practically shielded from all ordinary magnetic fields. Normal earth's field introduces an error of about 1/10 of one per cent. in unshielded instruments and such instruments should not be used nearer together than 18 in. If placed side by side, these instruments react on each other and an error of one per cent. may very readily be introduced.

The generally accepted model of voltmeter for measuring alternating Potential is of the dynamometer type. Those designed for 110 volt circuits have a resistance of from 1500 to 2000 ohms or about 12 to 15 ohms per volt. The resistance of the instrument is somewhat affected by temperature on account of the percentage of copper which it contains, but this is almost exactly compensated for by a corresponding temperature effect on the spring. Double scale instruments of this type should be limited to a ratio of two to one between scales, or with special designs, four to one. When designed for the higher scale, bringing out a tap for less than half scale introduces more copper in the circuit than the spring will compensate for, and frequency errors must be expected on account of the change of the instrument's time constant. In building double scale instruments with a ratio of four to one between the scales, it is customary to design it so that frequency and temperature errors are negligible on the lower scale. The result is an instrument which takes a large current, and the key must not be permanently depressed on the high voltage. Even special design will not permit self-contained instruments to be made with a ratio of more than four to one between scales, and greater ratios should be obtained by means of external multipliers. These dynamometer instruments should be protected by means of a suitable shield from any ordinary magnetic field, since, unshielded, they have an error of about one per cent. due to normal earth's field.

Although designed primarily for alternating currents, when there is no very marked difference between reversed readings they may be used on continuous current circuits by considering the correct reading as the mean

of the reversed observations. When used with potential transformers, the errors of the transformers must be added to the normal instrument error. Account must be taken of the regulation of the transformer, as affected by the connected load and also by the frequency of the circuit on which it is used. A regulation of from one and one-half to two per cent. between voltmeter load and full load is not improbable. The correction factors for the transformers can be supplied by the builders and should be taken into account where best accuracy is desired.

#### CURRENT.

The D'Arsonval ammeter for measurements on continuous current circuits differs from the voltmeter only in regard to errors due to temperature. In this respect, however, it differs materially and is often credited with an accuracy which it does not possess. Temperature changes affect the accuracy of the instrument in three different ways.

First, in those types of instrument where an attempt is made to avoid errors on account of change in room temperature, it is necessary that the shunt should have the same temperature coefficient as the instrument itself; and, since this coefficient is not low, five or ten minutes after such instruments have been connected, errors of two or three per cent., or even more, may be noted. These errors are due to the fact that the shunt is absorbing energy and increasing in temperature more rapidly than the measuring circuit.

Second, where an attempt is made to avoid the error by making the shunt of zero temperature coefficient material, an error due to change of room temperature is introduced. Since the temperature coefficient of the measuring circuit is practically half that of copper, an error of 1/10 or 2/10 of a per cent. is caused by each degree C., which the room temperature changes. This error may, however, be reduced to a negligible quantity by using shunts which have a drop of 200 mv. in place of the 40 or 60 mv. used in switchboard shunts. The extra size and weight are well warranted on account of the improved accuracy obtained.

The third error is found in those shunts which have zero coefficient materials and is due to thermo-electric currents set up in the measuring circuit. These currents are caused by difference in temperature of the shunt terminals. Such differences in temperature may be due to improper contact with the bus, to a difference in circulation of air at the two ends, or more usually, it is due to the Peltier

effect. Such thermo-electric currents may be avoided by using materials which have practically no thermo-electric difference of potential between the metals of the terminal and the shunt strip, or by adding a thermo-electric compensator which sets up a thermo-electric effect of equal magnitude and opposite sign.

Ammeters for the measurements of alternating currents are usually of the iron vane type. The only error which is characteristic of this type of instrument is that due to variation in wave form and this error is within one-half per cent. When used with current transformers, errors of considerable magnitude may be introduced. These errors increase as the impedance of the secondary circuit of the transformer increases and as the primary current diminishes. Where a five ampere instrument is used as the only load on the secondary circuit of the transformer, about 1/5 scale inaccuracies greater than one-half per cent. are not liable to be found. It is not permissible to substitute a two ampere instrument for lower readings unless the corresponding curve of the transformer under the new condition is at hand, for the inductance of the two ampere instrument is more than six times that of the five ampere and this additional load on the secondary introduces considerable error. Where transformers, in addition to the portable ammeter, carry a load of one or two stationary instruments and a trip-coil, an error of 3 per cent. to five per cent. at 1/10 load is by no means improbable and an error of one-half per cent. at full load is to be expected.

#### ENERGY.

Portable indicating wattmeters for the measurement of energy are of the dynamometer type and on continuous current circuits, or non-inductive alternating circuits, their characteristics do not materially differ from those of the dynamometer type of voltmeter. But when used on highly inductive circuits, or with transformers, additional errors are introduced. Errors due to mutual induction of the two circuits are small and may be neglected in commercial measurements. Errors of self induction may not be neglected in measuring highly inductive circuits such as core losses of some transformers. The best instruments have an inductance of potential circuit of about 1/100 henry and at 60 cycles a displacement of potential current of approximately five minutes. Consequently, when used in connection with inductive circuits of power factor 1/10, the instruments indicate one and one-half per cent. higher than the true watts and at one-fourth power factor, half of one per cent.

Instrument connections should be so made that the loss of the potential circuit rather than that of the current circuit, is included in the reading and this loss should not be deducted until after the correction factor mentioned above has been applied. Although this error on low power factor tends to cause the instrument to read too high on lagging load yet it is not unusual to find an instrument reading low on low power factor and the magnitude of such error is sometimes greater than that due to self induction of the potential circuit. This error is usually due to eddy currents in the metal part of the instrument. It varies with the frequency, current, and power factor of the circuit and with the position of the moving coil at the time the measurement is made. No correction factor can be given, but with proper design the disturbance may be reduced to a negligible quantity. In these low power factor measurements, care must be used not to overload the current coil of the wattmeter, for its capacity is often very much exceeded before the instrument is at one-half scale deflection. A short circuiting switch across the current coil is recommended.

When used with either current or potential transformers, or with both, the errors mentioned in connection with voltmeters and ammeters must be allowed for in addition, the phase displacement between the primary and secondary circuits of the transformers must be taken into account. The magnitude of this displacement depends principally upon the design of the transformers and the time constant of the devices in the secondary circuits. In well designed potential transformers, this phase displacement will not amount to more than five or six minutes at light secondary load, and the secondary potential leads the primary. As the full secondary load is approached, if the load is non-inductive, such as potential circuits of indicating instruments, the displacement may become 10 min. lagging, while if the load is mostly inductive, as for example, the potential circuits of induction meters, it may become 30 to 35 min. leading. If the current being measured is non-conductive, no appreciable error is introduced by this change, but with power factor one-half and a fully loaded potential transformer, the instrument may read one-half per cent. high or one and one-half per cent. low, depending on whether such load is principally non-inductive or highly inductive. With lightly loaded potential transformers, this error would not amount to more than one-half per cent.

In current transformers this dis-

placement of phase between primary and secondary current is usually greater than in the potential transformers. With one or two instruments on the secondary and full current in the primary, it may amount to 30 or 40 min., and the secondary current leads the primary. As the primary current decreases, this angle increases. At one-fourth load it is about one degree and at 1/10 load, about one and one-half degrees. On non-inductive loads the errors introduced are negligible. At power factor one-half, these errors become one and one-half per cent. at full load, three per cent. at quarter load and four and one-half per cent. at 1/10 load, and the instrument reads high on inductive load. It is therefore evident that combinations of transformer and instrument errors may not infrequently occur in which the error of the wattmeter reading may exceed five per cent. at power factor as high as one-half and that an accuracy better than three per cent. is not to be relied upon without taking all possible precaution and having at hand the correction factor for each individual piece of apparatus used. With such correction factors applied, errors greater than one to one and one-half per cent. need not be expected.

#### TIME.

The accuracy of stop watches is generally very much overestimated. Watches with compensated balances and well jeweled bearings are purchased. It is a poor watch which cannot be adjusted to keep time with an error not greater than one minute per week. That is, as a time piece, its error is within one hundredth part of one per cent. The balance wheel of a watch completes its excursion of approximately 250° in one-fifth of a second. It is necessary for good time keeping qualities that its motion should be free as possible and that it should be entirely disconnected from the train for the greatest possible portion of this excursion. It swings entirely free for approximately 240°, and unlocks the escapement for 10°, during which time the train drives the hand forward one-fifth a second division and again locks it from any movement during the next 240° of the balance wheel excursion. In other words, the hands of a watch are absolutely stationary during 95 per cent. of any interval of time and it makes no difference in the movement of the stop hand, whether it is thrown in mesh at the beginning or the end of an excursion of the balance. Therefore, with a perfect time piece, a perfect stop mechanism and absolutely no error on the part of the observer, an error of practically one

beat or one-fifth second may easily occur in measuring time. In 30 sec. observations, this error may amount to two-thirds per cent. When we add to this error those due to imperfect stop mechanisms, a throw of the hand in the interval between freeing it from the friction clamp and meshing it with the train, a similar throw in disconnecting from mesh and again clamping it, and the inaccuracy of the meshing itself, it is not difficult to realize that an additional error of one-half per cent. may be introduced. The only precautions which can be taken are to use two stop watches, one in each hand, to practice operating the stop mechanism with as little jar as possible to the watch, to reject any observation in which the watches do not agree within two-fifth second, and to refuse absolutely any measurement covering a period of less than 50 or 60 sec.

In conclusion permit me to express the hope that nothing in this paper may be considered as a reflection on reasonable accuracy of portable measuring instruments. I have sought only to show that laboratory accuracy may not be obtained under other than laboratory conditions, that errors of one or two per cent. represent reasonable commercial accuracy and that even this may not be relied upon unless the best judgment is exercised in the selection, care and use of portable instruments. Purchase those instruments which are best adapted to the conditions under which they are to be used, place them in the custody of an experienced instrument man and give him facilities and authority in control of them which will insure their proper use.

#### The New Westinghouse Nernst Lamp

The new Westinghouse Nernst units now being placed on the market by the Nernst Lamp Company represent the most notable development of the glower principle that has taken place since the introduction of the Nernst system into America. Representing a high increase in efficiency and many improvements in mechanical construction, they at the same time remove the former limitations of the system and open up for it a broader field than that covered by any other lighting system. Whereas the system has in the past been limited to commercial lighting, units are now equally well adapted to domestic lighting.

The mechanical construction of the new units naturally divides them into two distinct classes—the single glower and the multiple glower, though both classes represent the same principle and are uniform in illuminating value.

The single glower lamps are all provided with screw bases and screw burners. They are made in four different sizes—66, 88, 110 and 132 watts. The screw base enables them to be used in any fixture and to be



COMPLETE WESTINGHOUSE NERNST LAMP.

installed as single units or in groups. The screw burner is a new and distinctive feature that brings their renewal on a par with ordinary incandescent lamp practice.

The burner consists of a simple and rugged combination of glower and heater which is furnished to the user ready to screw into place. No manipulation of any sort is required and all that the central station furnishing the lamps has to do is distribute the burners received from the factory in individual packages and receive the old ones, for which an allowance is made, in return. The four different sizes afford a wider range than was formerly available in single glower units. The 132-watt unit puts into the screw base class a lamp giving a higher candle-power than the old two-glower terminal post lamps.

All these units are made for both alternating and direct-current and 110 and 220 volts.

The multiple glower lamps are made in three different sizes, two-

glower, 264 watts; three-glower, 396 watts; and four-glower, 528 watts. All operate at 0.6 instead of 0.4 amperes, thus requiring less handling in renewal for equal current consumption. The new three-glower lamp gives the same candle-power as the old six-glower. A comparison of the two shows a great saving in renewal in favor of the former, for it requires but three glowers and one heater (of the new wafer type), while the former required six glowers and four heaters.

The new lamps represent improvements in every mechanical feature.

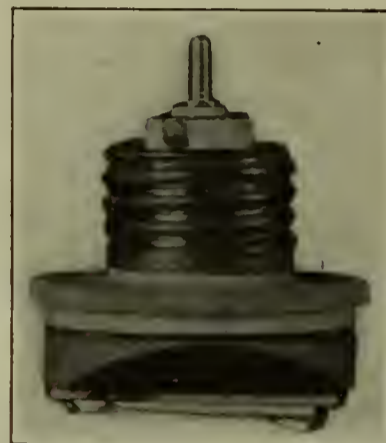

SCREW BASE OF NEW WESTINGHOUSE NERNST LAMP.

The ballast is larger and much more rugged—making it capable of withstanding heavy voltage fluctuation. It is provided with a bayonet spring base instead of plugs and its replacement is extremely simple. Easy access is provided by the construction of the lamp body, which separates.

The body, which is of a new and more pleasing design, is provided with a cap to conceal the terminal posts. An improved type of globe holder facilitates trimming and prevents breakage. The holder is of a new design, embracing the wafer heater which is renewed by simply slipping a ready-mounted heater into position. Its renewal requires no adjustment of the glowers and cannot possibly displace them or injure them in any manner. The glowers representing a new combination of rare earths are made in tubular form instead of solid. Their efficiency is about a third greater than that of the old type glower.

Multiple glower lamps are furnished with pendants or with suspension hooks as desired. The pendants are made in several different patterns and are furnished as a part of the unit.

On account of their simplicity and rugged construction, low maintenance cost is found in both the single glower and multiple glower units. It is claimed that this fact reduces the total cost of light to a lower figure than that reached by any other system.



**New Holophane Reflectors for Tungsten Lamps**

The Holophane Company has just completed the designs for an entirely new line of reflectors for tungsten lamps. These reflectors are not only more efficient than old styles but a number of remarkable improvements have been incorporated in their design which even the Holophane Company's engineers have heretofore considered unattainable. The reproduction here published is characteristic of all these reflectors.

The new tungsten reflectors are of three types which will be known to the trade as the Extensive, Intensive and Focusing types. In appearance all are similar to the original "bowl type" Holophane reflectors designed for Gem lamps, but each of the three new types above named gives a distinctive distribution of light. The Extensive gives an improved bowl type distribution; the Intensive a good general distribution downward; while the Focusing type is a strong concentrator. The reflectors were designed to fit the requirements of modern store, office and hall lighting, and so fully do they serve the purpose intended that illuminating engineers are of record as stating that they have almost ideal photometric curves. In the preliminary engineering work con-

nected with these new types, the engineering department of the Holophane Company was ably assisted by Mr. A. J. Sweet of the Westinghouse Company.

In the designing of the reflectors an entirely new principle was evolved—that of the "merging prism." As is well known, Holophane reflectors having a continuous prism from the collar to the edge lose considerably in efficiency owing to the fact that the prism is much larger at the bottom than at the neck. To prevent this the Holophane Company designed what is known as the "equal step prism" reflector, in which prisms of practically equal size are run in several banks from neck to top. In the new types instead of an abrupt step between the banks of prisms, the several banks are merged one into the other, which not only adds greatly to the beauty of the reflector but at the same time gives the maximum of efficiency.

The new "merging prism" reflectors are made for 40, 60 and 100 watt tungsten lamps, three types, as above described, for each size of lamp. This makes a very compact line and one which is uniform in appearance.

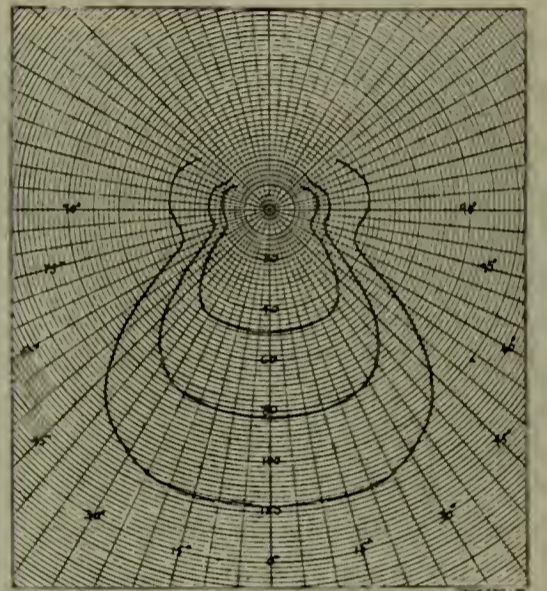

HOLOPHANE INTENSIVE REFLECTOR

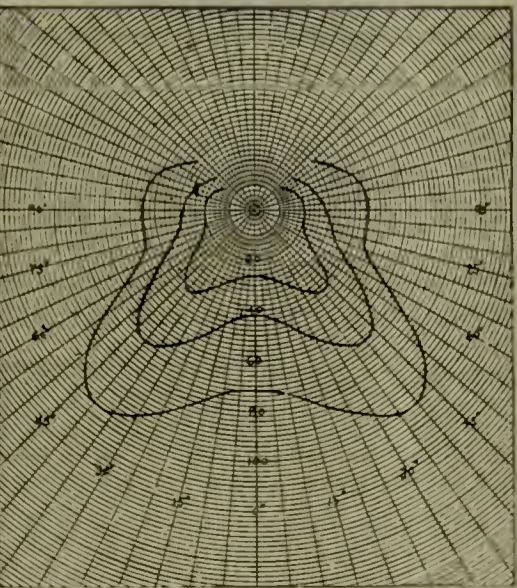

HOLOPHANE EXTENSIVE REFLECTOR.

**Battery Charging Rheostat**

The demand for a battery charging rheostat which will not only meet all requirements of battery-charging service but which shall possess automatic protective features as well, has led the Cutler-Hammer Mfg. Co. of Milwaukee, to place on the market the panel illustrated on next page.

This battery-charging rheostat consists of a slate front mounted on an angle iron frame containing the resistance, the whole being designed for attachment to a wall or switchboard.

The panel, which carries all of the operating mechanism, consists of three separate pieces of slate. On the face of the uppermost slate are mounted the terminals, or binding posts, and a Weston volt-ammeter. The middle slate carries a double pole knife switch and fuses (National Electrical Code Standard) and below these the contact segments and operating lever, by means of which the charging current is regulated. On the slate at the bottom of the panel are mounted the automatic, protective devices, which are:

(1) A low-current cut-out which automatically opens the circuit if the current drops to a predetermined minimum. This prevents the battery from discharging into the line should the line voltage drop below that of the battery.

(2) A maximum voltage cut-out. This automatically opens the circuit when the battery voltage reaches the

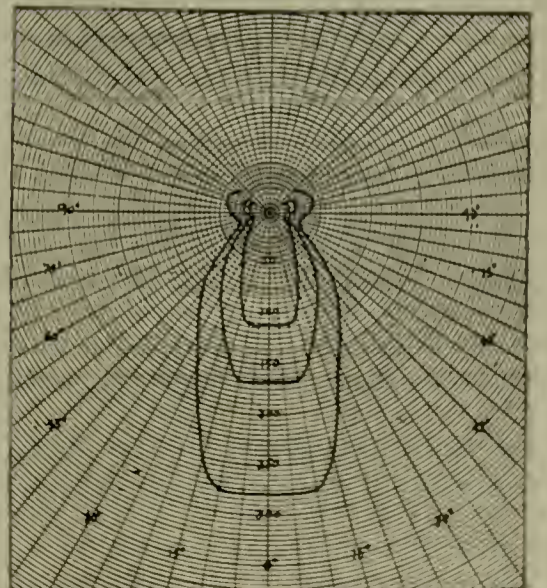

HOLOPHANE FOCUSING REFLECTOR.

point at which the cut-out is set to operate.

(3) A solenoid switch, the opening or closing of which breaks or makes the main line charging circuit.

(4) An overload circuit-breaker which automatically opens the circuit if the charging current rises to the point at which the breaker is set to operate. This insures the battery against being charged at an excessive rate.

The operation of this type of battery-charging rheostat is as follows: After the battery and line connections have been made the operator first closes the knife switch and then

the third contact segment as described above. It may then be moved further and further to the right, cutting out one step of resistance after another and increasing the amount of current until the desired amperage (as indicated by the ammeter) is obtained.

Should the current fail, or reverse, the low-current cut-out (1) will release its plunger, thus de-energizing the solenoid switch (3), which will in turn open the main circuit. Should the charging current reach the point at which the overload circuit-breaker (4) is set to operate this will open the main circuit. Finally, when the charge is continued until the battery reaches the voltage at which the maximum voltage cut-out (2) is set to operate, this will automatically open the circuit, thus insuring the battery against an overcharge.

It will be evident from the above description that the use of this panel protects the battery under all charging conditions, as it not only guards against an excessive charging current, but also prevents the battery discharging back into the line should the line voltage fall below the voltage of the battery. It possesses, moreover, the advantage of requiring no attention after the charge is once begun, since the maximum voltage cut-out (2) will cut off the current of itself when the battery is fully charged.

As an additional protection the operating lever is provided with an electrical interlock which prevents the operator from closing the circuit to the battery except when the lever is in the "off" position, that is to say, with all resistance in circuit.

These battery-charging rheostats are made at the New York works of The Cutler-Hammer Mfg. Co., 130th St. and Park Ave., New York City.

#### Machine Tool Controller

The self-contained drum type machine tool controller here illustrated is a recent addition to the line of electric controlling devices designed for use with motor-operated machine tools.

It possesses the advantage of combining in one compact piece of apparatus the speed-regulating mechanism and the resistance, instead of constructing these separately and requiring connections between the two to be made after the apparatus is installed.

Fig. 1 is a front view of this new type of controller and shows the removable resistance units mounted in the lower half of the controller with insulated wires running from each unit to the metal "fingers" in the upper part of the device. These units constitute the armature resistance and are employed for starting duty only.

Fig. 2 is a rear view of the same drum and shows another type of resistance unit — also removable — mounted on the back of the controller. The four units shown in this view constitute the field regulating re-

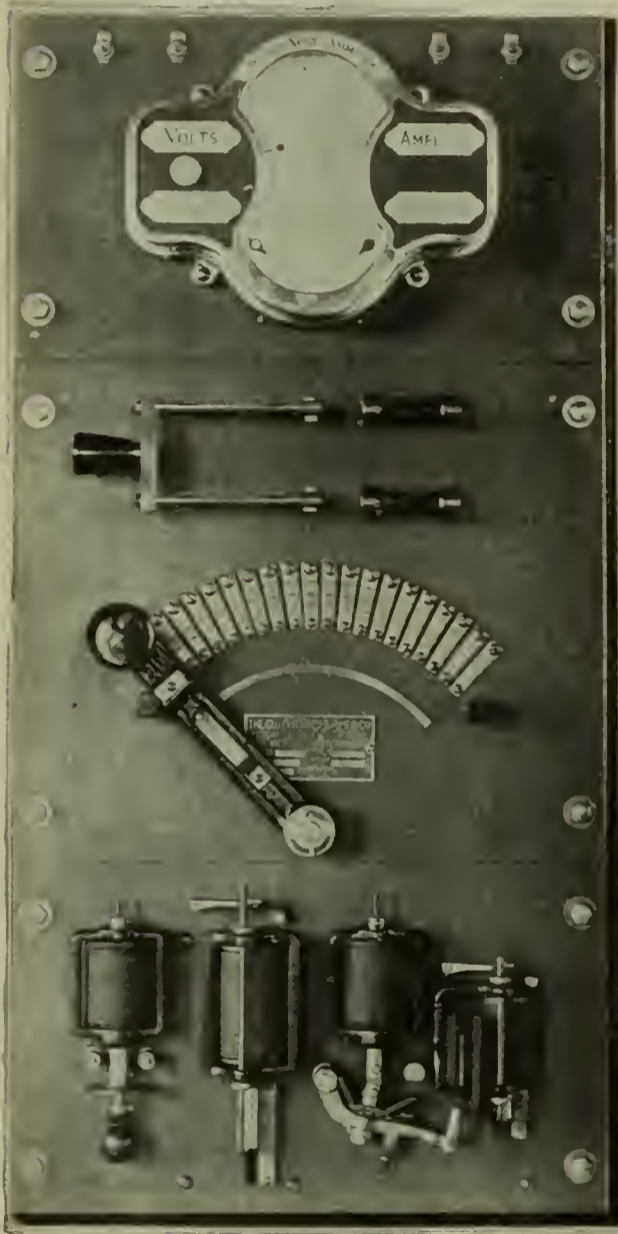

1 2 3 4  
CUTLER-HAMMER BATTERY CHARGING RHEOSTAT.

moves the operating lever forward to the third contact segment, at the same time raising the plunger on the low-current cut-out (1), thus energizing the solenoid switch (3), which closes and permits the charging current to flow to the battery through the resistance.

If at the beginning of the charge the operating lever is not in the starting position (that is to say, resting against the rubber stop-post at the left) it must first be brought to the starting position and then moved to

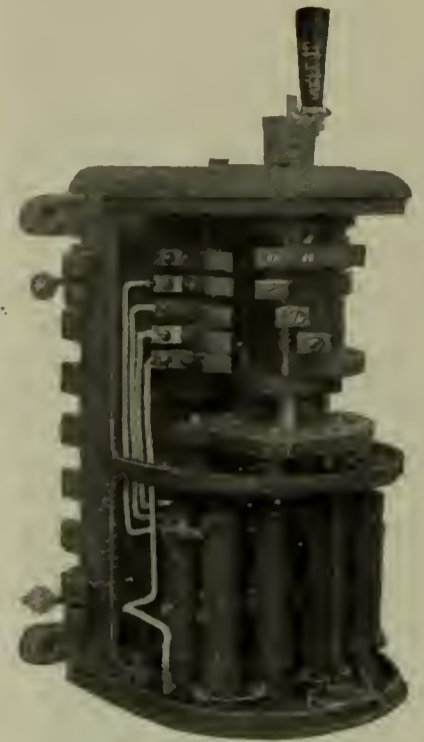

Fig. 1.  
FRONT VIEW (COVER REMOVED) SHOWING ARMATURE RESISTANCE UNITS MOUNTED IN LOWER HALF OF CONTROLLER.



Fig. 2.  
REAR VIEW (BACK PLATE REMOVED) SHOWING SHUNT FIELD RESISTANCE UNITS MOUNTED ON BACK OF CONTROLLER.

sistance and are divided into 20 steps, providing a range of speed variation of two to one, or three to one.

These controllers are made for both reversible and non-reversible motors, ranging from one to seven and one-half horse-power, and are designed for use on either 100 or 220 volt direct-current circuits. They are made by The Cutler-Hammer Mfg. Co., of Milwaukee.

### New Plant for the Electric Cable Co.

The Electric Cable Company, New York, whose plant at Bridgeport, Conn., was destroyed by fire last February, has completed a set of brick buildings which embody many of the best ideas in factory design. The works are near the main line of the New York, New Haven & Hartford Railroad and about one mile from Bridgeport. Owing to the grade conditions of the site, the lower floor of each building is sunk sufficiently to permit the upper or main floor to be flush with the floors of the cars going on and off the siding. The roofs are carried on white enameled steel girders and the walls, except for the gray doors, are also painted white. The skylights are of liberal size and the number of windows is limited only by structural conditions. The buildings are surrounded by fine grass lawns. The main building, called No. 1, has the shipping and receiving room in the front part of the upper floor, while back of it extends for about 250 ft. what is probably the largest shop in the country used exclusively for magnet wire. The lower floor of this building serves for machine and carpenter shops. The power plant, behind building No. 1, contains an American Ball engine, Crocker-Wheeler generator, Bigelow water-tube boilers, water-feed regulators, etc. The coal storage is back of the boiler. The offices are in the connecting wing between buildings Nos. 1 and 2. The upper floor of No. 2 is for the weatherproof department, which contains braiders of every size, while the lower floor is for handling rubber-covered wire. Building No. 3, which is behind No. 2, contains the impregnating and finishing department, the equipment of which includes several tanks for vacuum impregnation. This last building is entirely isolated to minimize the fire risk and is the only one away from the siding. Building No. 4 is a storehouse for raw material and No. 5 is for the storage of finished material. Behind No. 4 is a small garage for storing automobiles. Elevators are installed in all the shop structures. These are of the Springfield type and capable of raising two of the heaviest cable reels likely to be handled. Transportation of smaller objects along one floor is effected by Yale & Towne manual hoists. The machines in the different shops are all group-driven by Crocker-Wheeler motors. There are about 12 groups in all and the largest motor is 50 h.p.



H. H. CUDMORE  
GENERAL SALES MANAGER OF THE  
BRILLIANT ELECTRIC COMPANY

Mr. H. H. Cudmore has been engaged by the Brilliant Electric Company of Cleveland as general sales manager. Mr. Cudmore has for the past twelve years been identified with electrical jobbing interests in and near Cleveland. As the product of the Brilliant Company is marketed very largely through jobbers, his knowledge and experience in the supply business will enable him to serve such customers to the best advantage. Mr. Cudmore assumed his new duties last September, since which date he has been on an extended trip through the East, making the acquaintance of his trade and studying business conditions.

### A New 25-Watt Tungsten Lamp

The latest addition to the line of tungsten incandescent lamps for standard lighting circuits (100 to 125 volts) that is being placed on the market by the General Electric Company is a 25-watt, 1 to 1 $\frac{3}{4}$  watts per candle, lamp made in a practically identical bulb to that used for the ordinary 16 c-p carbon lamp. This lamp has the same diameter and base and approximately the same length as the familiar 16 c-p. unit.

This lamp will burn in any position and its size adapts it for use in any shade or fixture suitable for the 16 c-p. carbon lamp. It can be substituted, therefore, lamp for lamp in all present installations.

At 1 $\frac{3}{4}$  watts per candle the 25 watt lamp gives 20 c-p. or 25 per cent. more light than the ordinary 16 c-p. lamp. The energy consumed is one-half that of the best 16 c-p. carbon lamp and considerably less than one-half the energy consumed by a 16 c-p. carbon lamp of similar life—600 hr.

The General Electric Company, as previously announced, has been greatly increasing its manufacturing facilities and is now prepared to manufacture this lamp together with the 40, 60, 100 and 250 watt lamps, at the rate of 35,000 lamps total output per day.

Ample stocks of the larger lamps are carried at the main lamp sales office in Harrison, N. J., and at the various local sales offices throughout the country. The stock of the new 25 watt tungsten is at present somewhat limited, but the factory capacity is ample to maintain a reasonable delivery on all ordinary orders.

The list price of the new lamp is 85 cents plain and 90 cents frosted, subject to the regular discounts adopted September 1st. The lamp will burn in any position and can be substituted in the regular course of renewals.

### A Big Nernst Lamp Order

The G. M. McKelvy Co., of Youngstown, O., have placed an order with the Nernst Lamp Co. for the new Westinghouse Nernst Lamps for the entire lighting of their new four-story store building. The installation will consist of 36 three-glower lamps for the first floor, 69 two-glower lamps for the second and third floors and 75 132-watt lamps for the basement and fourth floor.

### Westinghouse Motor Contract

The Virginia and Mexico Mining & Smelter Corporation, of Hostotipaquillo, Jalisco, have in transit from the Westinghouse Electric & Manufacturing Co., of Pittsburg, Pa., through G. & O. Braniff & Co., a number of electric motors for their new mill. There will be some 15 motors, totalling over 300 h.p., the majority of which will be used for belt drive.

### Cutler-Hammer Co. Gets National Battery Co.

Announcement is made by the National Battery Co., of Buffalo, that the receivership under which this company has been operating since last February was terminated August 19th. All claims against the National Battery Co. have been settled and the entire property has been restored to the stockholders.

It is also stated that full control of the reorganized company has been secured by The Cutler-Hammer Mfg. Co., of Milwaukee, well known as makers of battery-charging rheostats and other electric controlling devices.

The plant of the National Battery Co. will remain at Buffalo, but the business will be conducted under new management and with ample capital.

### New Westinghouse Lamp Works

The new plant of the Westinghouse Lamp Co. at Watsessing, N. J., occupies a level site of 15 acres of land, on which are erected three structures—a main manufacturing building, 521 by 100 ft., three stories high, with a floor-to-floor height of 17 ft. 4 in.; a storehouse, 140 by 80 ft., four stories high; and a power-house, 83 by 66 ft. The foundations of the buildings have been made of sufficient strength to permit the addition of one or more stories when desirable. All buildings are designed to be as nearly fireproof as possible, being constructed throughout of reinforced concrete.

Lighting and heating are supplied from a central power plant, which furnishes current for elevators, pumps,

building, in the south end of the first floor, are 17 electrically-driven vacuum pumps.

All mechanical processes are operated by electric drive, and the latest and best appliances used in lamp manufacture have been secured. Many of the machines used in these new works have been developed by the company's engineers and the company has built the machines at the works. The factory is therefore designed and equipped to meet the best present-day methods in lamp manufacture.

In the boiler room are located the feed pumps, feed water heaters, hot water heater and circulating pump for the heating system in the buildings, and the mechanical draft apparatus.

The buildings are heated by indirect

100 ft. high. Further fire protection is provided by a system of underground piping in the yard connecting with fire hydrants. This system is fed by a 1500 gal. underwriters' fire pump, which draws its water from an underground reservoir of 200,000 gal. capacity.

### The Stanley Patent

In the United States Circuit Court for the Western District of Pennsylvania, held at Scranton, Pa., October 2, 1908, Judge Robert W. Archbald handed down a decision in favor of the Pittsburgh Transformer Company in the suit of the Westinghouse Electric & Manufacturing Company for infringement of the so-called "Stanley Patent" No. 469809. The Westinghouse Electric & Manufacturing Company having filed a motion for preliminary injunction against the Pittsburgh Transformer Company, Judge Archbald, immediately after the conclusion of the hearing on the above date, handed down his decision from the bench, holding in effect that infringement was not shown and the complainant's motion for injunction was denied. While the above patent has been the subject of a great deal of litigation during the past twelve years, it will lapse in another year.

### Renting the Tungsten Lamp

J. H. Hunnewell, General Superintendent of the Lowell (Mass.) Electric Light Corporation, is conducting an energetic business-getting campaign, using the rental of Tungsten lamps and free wiring as his most important persuasions. General Electric Tungsten lamps are being rented on a basis of 25 cents per month per lamp, using 100 watt 80 c-p. and the 60 watt 48 c-p. sizes. The rental price includes the lamp, shade and holder and whatever pendant or fixture is necessary. The plan is working so successfully that at present there have been in the neighborhood of 700 lamps installed and the business is increasing rapidly.

### Base Supporting Rail Joints

Standards for steam and electric railways of to-day are selected from the higher class of appliances, among which may be mentioned the products of The Rail Joint Co., makers of base-supporting rail joints for standard Tee rail sections, also girder rail sections and insulating joints to meet various conditions for track use at terminals and for signal work. The compromise or step-joint made by this company is equally popular with the company's other products, all being of the base-supporting character. Total output now exceeds 50,000 miles.



NEW WESTINGHOUSE LAMP WORKS, WATSESSING, N. J.

fans, and for manufacturing operations.

The power-house is directly back of the storage house and is designed to contain 1000 h.p. of Sterling boilers. The following installation furnishes the necessary power for the operation of the works at the present time:

One 250 kw. Westinghouse alternator, with one 25 kw. exciter.

One 50 kw. Westinghouse alternator, with 10 kw. exciter.

One 90 kw. belt-driven generator.

One 40 h.p. Westinghouse motor generator set to supply direct current.

One steam-driven air compressor, supplying air at from 3 to 5 lb. pressure for blow pipe work.

One motor-driven air compressor, belt connected, to supply air at 100 lb. pressure for distribution through the manufacturing building.

As a part of the power equipment, although placed in the manufacturing

radiation, large stands of heating stacks being provided on the ground floor, through which the outside air is drawn by electrically-driven fans and distributed in galvanized iron ducts through all parts of the buildings. Hot water is circulated through the heating stacks by an electrically-driven centrifugal pump located in the boiler room of power-house, where the water is heated by exhaust steam. On the top floor of the main building, where there are a large number of operatives, and where the manufacturing processes require a considerable number of open flames, an additional mechanical ventilating system is installed.

Special attention has been given to the matter of fire protection, and the entire plant is equipped with automatic sprinklers which are supplied with water from a steel tank of 100,000 gal. capacity, placed on a tower

# THE ELECTRICAL AGE

Volume XXXIX. Number 10.  
\$1.00 a year; 15 cents a copy

New York, November, 1908

The Electrical Age Co  
New York.

ESTABLISHED 1883

Published monthly by

The Electrical Age Co., 45 E. 42d Street, New York.

J. H. SMITH, Pres. C. A. HOPE, Sec. and Treas.  
JOHN HAYS SMITH, Editor.

Telephone No. 6498 38th.

Private branch exchange connecting all departments.

Cable Address—Revolvable, New York.

## SUBSCRIPTION RATES

United States and Mexico, \$1.00.  
Canada, \$1.50. To Other Countries, \$2.50

## NOTICE TO ADVERTISERS

Insertion of new advertisements or changes of copy cannot be guaranteed for the following issue if received later than the 15th of each month.

### Permutators

It is hardly necessary to point out how frequently in the course of electrical work it becomes necessary to change over alternating current to direct current, or vice versa. The most eloquent testimonial on this point is the fact that in spite of the great improvements made in both synchronous and induction motors during the last few years, the output of current-changing devices continues to increase, and to-day in the United States more than a million electrical horse-power are passing through rotary converters alone, not to mention what is being changed by motor-generator sets and mercury-arc rectifiers.

Of these three well-known current-changing devices every one has its infirmities. Those of the rotary converter are but too well known, and are shared more or less by the bulkier and more costly motor-generator set with its diminished efficiency and none too great stability in operation (unless induction motors are used). As to the mercury-arc rectifier, it has not yet been perfected for large capacities, and according to those who are pushing it, there are numerous difficulties in the way of perfecting it for large units. Moreover, the maintenance charges on these devices are rather high, and for their size they require considerable auxiliary "gear."

Nevertheless, with all their faults, motor-generator sets and rotary converters have so far had to do the bulk of the current-changing work of the world and, in general, they do it fairly well. Yet many have felt that there is room for great improvement, and that the ideal device for passing from

alternating to direct current, and the reverse, has not yet appeared.

There are certain cases, however, in which the limitations of rotary converters, and their double-bodied competitors, are especially prominent. Perhaps the most important case is where they furnish current for tractive purposes, especially for heavy traction. The sensitiveness of these types of synchronous apparatus is greatly aggravated by the tremendous fluctuations of load, and by the large line-drops inseparable from this sort of service, unless disproportionate sums are invested in the supply conductors. Severe as these conditions are in ordinary electric railway work—and probably two-thirds of the rotary converter capacity of the country is so used—they become appalling when trunk-line railway operation is studied. As is well known, it is the desire to meet these conditions in a more economical manner that has led to the effort to get away altogether from direct current and low potentials by the use of the single-phase traction system.

The advocates of the single-phase traction motor, as so far developed, do not contend that it is the equal of the direct-current motor in most of the important qualities of a motor—especially of a motor for traction purposes. It would seem, therefore, that so long as direct-current voltages are relatively limited, and the performance of alternating-current traction motors admittedly inferior to that of direct-current motors, that the most desirable railway traction system is one employing high-tension alternating current for transmission and direct current at the motors. Up to the present time the only way of realizing these results has been through the widely used rotary substation system.

In the application of this system to heavy traction, with the increase in the total quantity of energy to be concentrated at one point—as, for instance, at the locomotive of a heavy train—the urgency of diminishing the mean distance between the substation and its load becomes imperative if the investment for conductors is to be kept down. As, with the increase in size of the tractive unit, the substation and its load begin to approach each

other in capacity, the tendency would be to take the substation aboard the train.

It is right at this point that the rotary converter, or motor-generator set—never very attractive, even with abundant operating space—become almost impossible. Weight, size, disposition, and operating characteristics all oppose the idea of finding a place for such apparatus in the very limited space available on our railway gauges. It may be said that it is this fact, or, which broadly considered, amounts to the question of the investment in the transmission between the generating station and the locomotive motors, that so far has prevented the general electrification of trunk-line steam railroads from making more rapid progress. And the probable solution of the problem lies along one of three lines—either the further improvement of the alternating-current traction motor, the development of high-tension direct-current transmission and transformation, or the combination of these two, *i. e.*, the perfection of a light, cheap, reliable and portable current-changing device.

In looking over the field devoted to machines of this type that are in the course of development, the device lately brought forward in France under the name of "permutator" seems to have some attractive possibilities.

In principle, the permutator is based on the fact that in any symmetrical transformer, provided with suitable windings and connected to a poly-phase circuit, there will be set up a rotating magnetic field which, in turn, generates alternating electromotive forces in the windings. By the use of taps placed at the proper points, and led to the bars of a commutator, which in this case we will suppose to be fixed, these electromotive forces may be distributed around the commutator very much as they would be in an ordinary rotary converter armature provided with no field and locked in position, but with the magnetic circuit completed by having a heavy, laminated, tight-fitting cylinder slipped on over the armature.

By means of a set of brushes, revolving in synchronism with the rotating field, and connected to a pair of collector rings, direct current may be taken from the commutator.

In such an apparatus, the only moving parts are the rotor of the motor driving the brushes, the shaft, brush-holder, brushes and collector rings. A vertical arrangement of this brush-driving mechanism, mounted in an annular transformer which also forms the stator of the motor, is what has been adopted for the latest form of the permutator. The result is a very light and compact machine of high capacity per pound and per square foot of floor space occupied.

In addition to these advantages, if the problem of good commutation is actually solved, the device should be exceedingly simple in operation, and robust enough to be considered nearly fool-proof.

Starting simply by closing the switch connecting it with its supply circuit, taking a starting current that is only a fraction of its rated full-load current, it is said to reach synchronism automatically in a few seconds by reason of its inherent characteristics and the extreme lightness of the revolving parts. Owing to these same characteristics, even with a 40 per cent. drop in the voltage of the supply circuit, it is claimed that it will not fall out of step.

With a good power-factor at all loads, and an efficiency superior to that of other types of commutating machinery, especially at fractional loads, it would seem that if the claims made for it are substantially true the appearance of the permutator marks a signal advance in the construction of machines of this kind.

All of these qualities: compactness, light weight, simplicity, hardy operating characteristics and high economy, are just what would be especially desirable in a portable current-changer, such as would be suitable for installing on an electric locomotive.

By the successful adaptation of such a device, the whole lesser brood of fixed charges on substations, such as buildings, distribution lines, attendance, etc., disappears from the ledger, and an electric locomotive capable of being supplied with high-tension alternating current, but with low-tension direct-current motors under it, would take up the burden of the steam locomotive for heavy railroad work under conditions more favorable alike to the balance sheet and to the time-table than any that have so far been attained.

In the article on permutators on page 250 of this issue, the more striking features of their make-up are no-

ticed, which, we believe, will be found to be not without interest to many of our readers.

#### The Westinghouse Reorganization

The creditors' committee of the Westinghouse Electric & Mfg. Co. has at last ratified the plan of the merchandise creditors' committee, and the successive steps to turn the property back to its stockholders will be taken very rapidly. Application has already been made to the New York Stock Exchange to list \$4,531,000 additional convertible sinking fund 5 per cent. bonds and \$9,560,000 additional assenting stock as required by the plan. A new directorate of sixteen members has been chosen, and J. W. Marsh, chairman of the merchandise creditors' committee, is to be chairman of the board of directors, and George Westinghouse will, of course, continue to head the company as its president.

Last year, when the company went into the hands of a receiver, matters looked very black indeed to some of the prognosticians. They shook their heads, said affairs were too badly tangled ever to straighten them out, and talked of selling out the property. They forgot it was not the property that constituted the company, but the splendid collection of men who composed it and manipulated the mammoth works and laboratories. They were, and are, the most valuable asset of the corporation.

At this time so general was the unbenevolence of the prognosticians, that one leading trade paper went so far as to omit any editorial reference to the biggest event of years. This, too, when the newspapers of the country were filled with conflicting stories. To their credit, however, be it said, that the press generally expressed the opinion that the work of the Westinghouse Company was too important not to be carried forward, that it was an economic necessity to the country, and that somehow a plan would be found to straighten matters out. Everywhere there was warm tribute to George Westinghouse and to his achievements, and the earnest wish that his company would go forward in its development work. It is a pleasure now to note that the well-wishes of all have come true, that the company will continue to aid the economical development of our country and continue to make epochal advances in the electrical arts.

#### Output Costs of Small Plants.

The question of the advisability of putting in a power plant or buying light and power from the local electric company is one that confronts everyone responsible for the design of a small industrial layout. It is hardest to determine in the case of the user of small amounts of power, because a plant on the premises is not worth while for very small power consumption, and for a very large one it is almost always advisable. The distribution through the day of the power load also enters materially into the discussion. Just where the lower limits of the field for the small plant lies has been and is the subject of considerable controversy.

As in all such questions, generalization is almost useless. Each case forms a specific instance governed entirely by the conditions involved and should be worked out by itself, just like a hydro-electric project.

In order to get an idea of how some cases actually do work out in practice, we have investigated a number of instances in which small plants have been installed, and have tried to determine the cost of producing their output. It is interesting to note in not a few of these cases that the small plant was installed to take the place of a service supplied by the local electric company, and in one instance at least the cause of the abandonment of the local service was that its cost from time to time had been arbitrarily raised, until the consumer was actually paying nearly three times the price originally charged for the same amount of power. This condition will not be met with in the large cities.

The fact that such a consumer is practically at the mercy of a "natural monopoly" is one of the indeterminate factors in the question, as also are the items of convenience, cleanliness, absence of noise, value of the space occupied by the plant, insurance and other elements of that character. For the present, we must lay these to one side, and concern ourselves only with those items which can be more or less accurately computed.

In the consideration of the subject, it naturally falls under two heads: first the production cost of mechanical power as compared with that of its purchase from an electric company; and second, the production cost of electric power from a gas or steam-driver plant as compared with its

purchase of an operating company.

It is evident that the difference in the economy of the two cases will be due to the extra cost involved in the installation and operation of the purely electrical part of the plants considered in the second case.

Influencing both of these cases, in most parts of the United States is the problem of heating the premises on or near which the plant is installed. And it is to be noted in many cases that the cost of operating the heating plant is as large or larger than that involved in the consideration of the light and power load. In fact, it is this consideration in a well-designed industrial layout that often dictates the choice of a steam-driven plant in preference to a gas-engine drive. Too often it is evident that the importance of the heating factor in the total economy of plant operation is not given due weight at the proper time; and as a result much money is often spent on refinements of the light and power outfit with resulting economies more than offset by waste in the heating plant. In not a few buildings exhaust steam may be seen floating away on the wintry air, while coal, paid for in hard money, is being crammed into the furnaces of divers styles of heaters on the same or neighboring properties.

Laying aside, for the present, the influence of the heating problem on the light and power layout, let us look at the relative costs when supplied from small plants and from the electric company's mains.

At the recent Electrical Show in Madison Square Garden, New York, one of the largest electrical companies advertised the monthly cost of power for operating a 25-h.p. motor as \$94.54, which corresponds approximately to \$60.50 per kilowatt year, and may be figured up from a basis of three cents a kilowatt hour as minimum cost. This figure compares favorably with the rates charged by the electric power companies in many of the large manufacturing centres of the Eastern states. In addition to this power cost, other items bring the total estimated monthly cost of the motor service up to \$98.74. Now the monthly cost of a 25-h.p. gas-engine installation may be fairly taken as follows:

COST OF INSTALLATION, COMPLETE, \$1150.	
Interest and depreciations, at about 15% . . . . .	\$14.40
Gas at 80c per 1,000 ft. (half load) . . . . .	57.20
Oil, waste and supplies . . . . .	2.50
Repairs, based on a average of five years . . . . .	5.00
Attendance, one hour per day at 15c . . . . .	4.50
Total cost per month	<u>\$83.60</u>

This is equivalent to a saving of about 16 per cent. in favor of the gas-engine plant.

If the comparison is made for units of larger capacity than the one given above, the showing for the same minimum rate will be more striking. The capacity at which it can be figured that it does not pay to install the small plant will depend, as above remarked, entirely on local conditions.

If the comparison is made between the cost of production of electric power from a gas-driven unit, the showing changes somewhat, and if the electric power be generated by a steam-driven unit—and no heating considerations enter—the change will be still more noticeable, and, of course, less favorable to the independent plant.

In our next issue we will try to show how the capacity of the plant and the type of prime mover affect the relative showing to be made under given conditions that may be assumed as representing typical cases in large cities, particularly in the Northern and Eastern states.

#### The Business Outlook.

The business outlook continues to broaden and the tariff question seems not to check the natural improvement which had set in before the election. To-day every indication points to a rapid revival of business. We may not strike a "boom" right away, and it is hardly desirable that we do, but there is a large anticipation of future needs. Manufacturers are beginning to place orders for raw material and consumers are coming into the market with substantial orders. Outside of the \$5,000,000 electrification of the New York terminals of the Pennsylvania, which has been given to the Westinghouse Company, there have been no orders of large magnitude. Manufacturers, however, report very substantial buying. The Allis-Chalmers Co. has recently closed a contract with the Northern Hydro-Electric Co., of Wisconsin, for five 1500-h.p. water-wheel units with the entire electrical equipment. The Crocker-Wheeler has received a large induction motor contract of 57 machines for the famous Estey organ works, and another one aggregating 2500 h.p. of induction motors for the Clark Thread Co., of Newark, N. J. The General Electric Co. has sold the Interborough Rapid Transit Co. a 6500-kw. exhaust steam turbine.

There has been a gradual strengthening of the copper market, and the price of the metal has advanced about a cent in the last 30 days. The large manufacturers are reported, however, to have stocked up for some time ahead.

#### Safety Engine-Stops.

The recent failure of central-station current in the City of Keokuk, Ia., due to the wrecking of the station by a runaway engine and bursting fly-wheel, amounts almost to criminal neglect on the part of the management in its failure to provide a suitable safety device to prevent just such a catastrophe. The city was wholly without light, many industrial enterprises were crippled and the accident carried with it loss of life. It is just this sort of thing which makes many manufacturers shy at the local central station, and failure to provide against it is culpable since there are several safety-stop devices in the market, at least one of which is well tried out and proven by over 4000 separate installations.

It seems pitiable that human life should be snuffed out for the want of a small safety-stop; and it seems strange indeed that a central station in a bustling town would lay itself open to failure, damage, loss of revenue and waning prestige for the lack of a small investment.

Here is just a word:

The safety-stop can be attached to any make of engine. The speed limit mechanism runs from the engine shaft and automatically makes electrical contact at any predetermined speed, usually 10 per cent. above normal. The stop is connected to the throttle valve of the engine, and when rising speed makes contact, the throttle closes very rapidly, but without jamming. Indeed engineers always use the safety-stop in shutting down, and always are aware of its operative condition. Its use carries with it its own inspection, which places it in a class outside of ordinary mechanism designed to operate occasionally. As many control circuits may be used with the device as may be required and they may be located in any part of the engine-room or power station. In case of a cylinder blowing, a strap or crank pin breaking, or other accident occurring, merely closing a knife switch shuts off the steam supply.

# The Permutator

THE beginning of the permutator would seem to go back to about 1888 when Zipernowski and Deri conceived the possibility of changing alternating to direct current by utilizing the currents induced by the action of a rotating magnetic field on a fixed armature provided with a commutator and synchronously rotating brushes. Efforts to realize the project, however, seem to have been discouraged by the appearance of a destructive and incorrigible sparking, as well as by the fact that the devices as used had no regulation to speak of. The incentive to overcome these difficulties was undoubtedly weakened by the more rapid development of the rotating armature type of machine, which gave a solution satisfactory enough for the time being. As the size and uses of current-changing devices tended to increase, other investigators from time to time turned their attention to the permutator, and in 1892 Hutin and Leblanc, Blondel and Sautter in 1896, and Leblanc again in 1902, devised various modifications of, and improvements on the original type. Finally, in 1905, Rougé and Faget, the inventors of the modern form of the device, had improved it until they were able to make an interesting exhibit of three 150 kw. machines at the Liege Exposition.

An excellent account of the different attempts at improvements, and the patents resulting therefrom, may be found in the "Zeitschrift für Elektrotechnik" of August and September, 1905, over the signature of J. Sahulka.

The following description is taken from a pamphlet issued by the company controlling the patents granted the inventors.

In principle, the permutator consists of a static transformer united in a more or less compact fashion with a non-inductive rectifier. The early rectifiers were the first types of these machines, one main difference between them and the permutator being that the direct current which they furnished was not truly constant, and was taken successively off the different phases, while the current from the permutator is truly constant and is taken simultaneously off the different phases. In order that a device may be a true permutator, as the word is herein used, it is necessary that the transformation take place in a static transformer, that is to say, in a transformer in which the variations and movements of the magnetic field are not united with any relative mechanical movement, and therefore do not

produce, even momentarily, any transformation of the electrical energy of the primary circuit into mechanical energy.

From this it appears that the essential difference between the action of a rotary transformer (or a motor-generator set) and that of a permutator is that in the first type of apparatus the transformed energy is changed either entirely, or in part, to mechanical energy and then re-transformed into the desired form of electrical energy, whereas in the permutator the change is wrought without the introduction of mechanical energy, the action being, so to speak, purely electrical and magnetic.

The multiple roles played by the different parts of the permutator render its description somewhat difficult. In order more easily to understand its action, it is better to consider each part separately.

These parts are three, namely:

1. The transformer, that is to say, the assembly of magnetic iron and windings to which the energy to be transformed is applied, and in which induced currents are generated under the influence of the variations of the magnetic field.

2. The motor for driving the revolving brushes, which, by reason of the rigorous synchronism which it must maintain in order to keep them in the commutating plane, is of a special character.

3. The collecting devices, commutator, motor-brushes and collector rings and brushes, which are also of a special nature because of the special conditions of commutation and the use of revolving brushes.

## THE TRANSFORMER.

In general, the transformer is composed of a magnetic core formed of a pile of iron laminations punched so as to form two annular rings as indicated in Fig. 1. The resemblance to the stator punchings of an induction motor is quite noticeable. In the slots formed by the assembly of these punchings, the primary winding is placed, somewhat in the fashion that induction motors were formerly wound in Europe. From the diagram it can be seen that if this winding is connected with a polyphase circuit, the iron becomes the seat of a rotating magnetic field, the inductive effect of which can be made to oppose the differences of potential in the supply circuit.

In the same slots might be placed an ordinary direct-current armature

winding, suitable sections of which could be connected to the bars of a commutator. In this winding the rotating field would produce the same effect that would be produced in a rotating armature winding mounted in a fixed field, as in the ordinary type of a direct-current machine. In the case under consideration a constant difference of potential becomes established between points at polar distances on the commutator and revolves in the same synchronously with the revolving field. A suitable arrangement of moving brushes and a collector ring would establish a source of direct current from the collector.

This is the principle and arrangement of the permutator first devised by Zipernowski. Such a machine could scarcely be expected to operate under any other than no-load conditions because of the changes in the

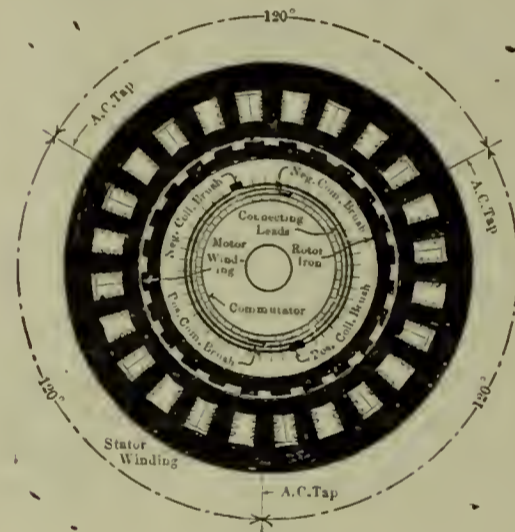

Fig. 1

distribution of the magnetic flux which would be produced with the imposition of load by reactions between the primary and induced currents.

On the modern permutator there are two windings on the stator iron. The first is the high-tension primary winding, designed very similarly to the primary winding of an ordinary transformer. The first workers on the problem stopped with this winding, as just noted, and to this was due their failure as there was no element present to suppress the tendency of the field to fluctuate with changes of load, which in turn caused variations of the speed of the brush-motor. Both of these effects helped to produce the serious sparking noted above. It is the second, or "vectorial" winding, as the inventor terms it, designed to correct the above defects that constitutes the distinctive feature of the new machine.

This "vectorial" winding is the basis of the United States patent issued



to M. Rougé, and without attempting here to go into its details, it may be noted that it consists of a special winding so designed and disposed as to compensate for the disturbing elements above noted, somewhat in the same fashion as the compensating winding in the alternating-current commutating motor. By its use, it is claimed that the following results are obtained:

The magnetic field is caused to rotate with a uniform movement, and to maintain a uniform shape and constant intensity.

Such a field induces a sinusoid electromotive force between symmetrical points on the windings.

Currents taken from the primary circuit for a uniform secondary output follow true sine variations.

The distribution of the field in the stator iron becomes independent of the load, giving a minimum eddy-current loss, the self-induction of each coil of the winding is practically neutralized, and the distribution of the induced difference of potential on the commutator becomes constantly sinusoidal.

If these claims are substantially true, and the brush-motor is rigidly synchronous, good commutation within reasonable limits of load should result.

#### THE BRUSH-MOTOR.

In some forms of the permutator the brush-motor was a simple synchronous motor, which might be—and in fact sometimes was—located outside the machine itself and used for driving the brush-holder by a belt.

Installing and operating considerations alike favored a motor concentric with the machine and mounted inside the hollow core of the transformer. The arrangement is indicated in Fig. 1, where the rotor stamping is the inner ring of iron, shown with projecting teeth. In order to avoid too large variations from synchronism under the influence of changes in the forces resisting rotation, the rotor is somewhat larger than would ordinarily be used for the actual work that it does. The power consumed in the motor circuit is not so small as would be expected. With carbon brushes and the brush tension ordinarily used the power absorbed is frequently two per cent. of the total rated power of the machine.

Synchronous motors, run at no load, are subject to oscillations, the effect of which might be very bad on the commutation in this case. In order to prevent this, the rotor is provided with special "damping" windings, similar to those used in the pole-faces of high-frequency rotary converters. The windings of the rotor are permanently connected to the collector

rings, and through them with the direct-current terminals of the machine.

If the rotor is now mounted inside of the transformer, in the leakage of the revolving magnetic field set up within the transformer, it will tend to revolve at the same speed. Upon attaining full, or nearly full speed direct current is impressed upon the windings, so that the motor under these conditions runs exactly as an ordinary revolving field synchronous motor, which for the reasons above noted is made rather large for the work it has to do.

By reason of the comparatively large section of the rotor iron and the small air-gap there is very little disturbance caused in the main magnetic field. With the magnetic poles on the surface of the rotor excited by direct current the action of the motor becomes rigidly synchronous. Further advantages of this scheme of drive are a good power-factor and a low iron loss.

In some of the larger sizes, the fine-wire exciting winding of the rotor is held in place by metallic wedges slipped into grooves in the teeth, which being connected together at the ends make a regular "squirrel cage" damping winding.

#### THE COLLECTOR PARTS.

A much-discussed point in a machine of this type, and one which has always been urged against it, is the use of revolving brushes. In addition to the ordinary difficulties that have been experienced with fixed brushes and a revolving commutator, the effects of centrifugal force have to be provided for. These forces, as is well known, are proportional to the quotient of the square of the speed divided by the radius of gyration. The speed for a given design and frequency is, in a measure, more or less constant, or it may be said to oscillate between very narrow limits. The radius of the brush-holding mechanism—and hence its radius of gyration—is necessarily proportional to the capacity of the machine. Difficulties with centrifugal force therefore decrease as the capacity of the machine increases. In very small sizes, such as 10 kw., at 50 cycles the centrifugal force may become as much as 200 times the weight of the brush.

It will be seen that under these conditions a very exact balancing of the masses of the brush-holder and brushes is indispensable.

The most obvious way to attack this problem is to have the brush provided with a spring of sufficient force to overbalance the centrifugal tendency of the mass of the brush at speeds reasonably close to the synchronous speed. In the case of a brush, the

normal pressure of which on the commutator might be a small fraction of a pound when standing still, at full speed this same brush might require the pressure to be increased to several pounds. Now if the centrifugal force amounts to as much as ten times the spring pressure, a variation of 10 per cent. in the centrifugal force would render compensation by means of springs impracticable. But a variation of 10 per cent. in the centrifugal force would correspond to a change of only five per cent. in the frequency, or say two and one-half cycles in fifty, a variation which is very frequent in commercial circuits, especially in those supplied from machines of small size and driven by poorly regulating prime movers.

The designers of the permutator have departed from the use of springs, other than small ones of sufficient force to insure contact at low speeds, and have devised a very ingenious brush rigging consisting of a counterweight which compensates that of the brush-holder and brush, and which can be pivoted successively at two points. The first, or lower speed, pivoting point is formed by the end of a spring and is closer to the brush-holder than to the counterweight so that as the system is acted on by centrifugal force the pressure on the brushes increases. After a certain speed has been attained the pivoting point shifts to its second position which is formed by a pin working in a slot. This second point is closer to the counterweight than to the brush-holder and if the speed continues to increase the centrifugal force tends to lift the brush, so that the brush pressure diminishes. Now between these two positions the pressure on the brushes has passed a maximum. By means of regulating nuts it is possible to regulate this maximum so that it exactly corresponds to the proper frequency.

By the use of this scheme of counterweights on the brush-holder, it is claimed that the difficulties have been obviated that were expected to result from the use of revolving brushes.

The brushes themselves are exactly like those that are used on ordinary direct-current generators, being generally of carbon.

The commutator and collector rings are very similar to those used in ordinary rotary converter practice.

#### GENERAL ARRANGEMENT.

The usual method of assembling the parts is shown in Fig. 2. As indicated, the vertical shaft arrangement is adopted as giving the lightest and most compact type of machine. It also has the advantage of lessening the chances of de-centering the rotat-

ing parts, permitting the use of a small air-gap.

At the bottom of a frame consisting of four cast steel standards, is placed the annular transformer with its windings suitably protected and connected to the hollow commutator concentrically mounted above. The vertical shaft carrying the rotor is mounted in a step bearing inside the transformer and extends up through the commutator, carrying the brush holder and collector rings, to a centering bearing at the top. Positive and negative terminals for the collector brushes are shown at the top, the alternating current leads are brought in at the bottom, close to the primary windings of the transformer. The whole arrangement is very compact and stable, and also permits easy access to the parts. Its advantages are even better appreciated when comparisons are made with other types of current-changing machinery as to floor space and weights.

#### OPERATING CHARACTERISTICS.

Assuming that the machine is well set up, and that the angular lead of the brushes is properly adjusted, the permutator is started by closing a switch connecting the primary windings of the transformer to a suitable alternating-current circuit. At the instant of starting the rotor winding of the brush-motor acts simply as the short-circuited rotor of an induction motor. The brushes, resting on the commutator, receive an alternating electromotive force of high frequency, which is thus impressed on the fine wire winding of the motor. This electromotive force gives but a small current in the rotor winding on account of the self-induction of the latter. On the other hand high electromotive forces are induced in the rotor winding itself by the rotating magnetic field, and these might tend to break down the insulation of the winding did not the brushes resting on the commutator form a sort of short-circuit, and so tend to protect it.

As the rotor increases its speed, the frequency of this induced electromotive force decreases and the exciting current in the rotor winding increases in proportion. When a speed close to synchronism is reached the frequency is so low that the rotor current has almost attained its normal value.

At exact synchronism this frequency is zero. The rotor is then excited by direct current and its magnetic poles are fixed in sign and at their strongest. This is the condition of equilibrium—if the resistance to rotation is constant, as it practically is in this case—and the device remains auto-

matically in synchronism, provided that the motor is properly designed, and the brushes are accurately set with reference to the commutating plane.

This cycle of starting events takes place in a few seconds. Rapidity and simplicity of starting are among the main advantages claimed for the permutator. This results from the lightness of the revolving parts which enables them quickly to attain synchronous speed with but a relatively small consumption of energy.

A second operating advantage, claimed for the permutator, is its stability in operation. As above noted, synchronism is the stable condition of its revolving parts, it being then, so to speak, in magnetic and electric equilibrium. If now, from any cause whatever, the voltage and frequency of the supply circuit undergo a change this equilibrium will be dis-

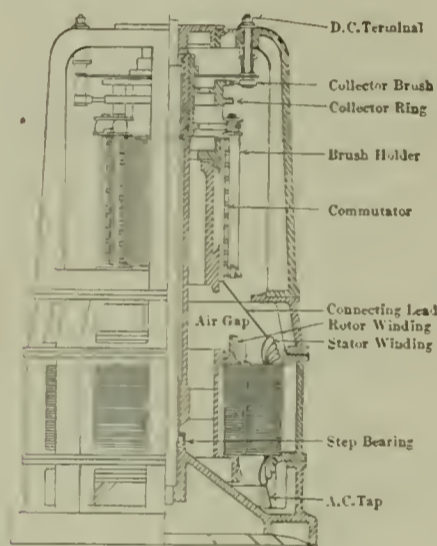

Fig. 2

turbed thereby, but it will tend to re-establish itself. The fact that the machine is what the inventors term "inherently synchronous" insures stable running.

The period of the oscillation which arises from a disturbance in frequency is absolutely defined and can be deduced from the equation of the couple of the brush-motor. The short-circuited "damping" winding on the rotor tends to reduce this oscillating action, which is nothing more or less than the familiar hunting of the rotary converter, and is suppressed in it by the same means.

It was probably at this point that the difficulties were experienced in the early days of the permutator which led to its temporary abandonment, and the "vectorial" winding, mentioned above in the description of the transformer, in conjunction with the damping winding, furnish the means by which it is claimed that the sparking troubles have been practically overcome.

Summing up the rather complicated

effects of the "vectorial" winding, it may be concluded that the result of their use is to cause a stable sinusoidal distribution of potential differences around the commutator. Now granting that this distribution is even approximately sinusoidal and that the synchronism of the brush-motor is approximately rigorous, it follows that both of these effects, *i. e.*, that of the "vectorial" winding, and that of the brush-motor's synchronism, work together to suppress the difficulties of commutation under a variable load, and constitute a solution of the permutator problem. For, owing to the shape of the sine curve it is evident that small variations in the position of the brush will not produce a great change in potential since the variations on either side of a commutating line will be small if the line lies on the center of a sine curve.

This means that there would be only a small drop in direct-current potential even in the event of quite an appreciable displacement of the brushes to either side of the commutating line.

On the contrary, with the ordinary forms of synchronous apparatus, it is well known that small variations in the angular speed of the revolving parts give rise to a continual interchange of energy between the machine and its supply circuit, and have bad effects on the operation of machines in parallel. The great difference in the effects of this kind of disturbance on the two types of machines is mainly because of the great difference in the amount of the kinetic energy involved in the transformation.

#### CERTAIN POINTS IN DESIGN.

The question of the satisfactory operation of a machine is, after all, determined by the correctness of design. With this fact in view, an examination of the principal features of the permutator, as now designed, is of some interest. An analysis shows some of them to be as follows:

#### INDUCTION.

The actual induction is not precisely known, as it is not possible to accurately determine the distribution of the flux in the parts. Assuming, however, an induction corresponding to the coefficient of the main and "vectorial" windings, it is found that an equivalent induction due to an ordinary winding of the same number of ampere-turns per slot, if figured for uniform distribution around the mean circumference, would be about 20,000 to 25,000 lines per sq.in.

Under the same hypothesis, the induction in the teeth would be from

50,000 to 80,000 lines, but the induction in both stator and rotor iron may vary between quite wide limits.

PERIPHERAL SPEEDS.

The peripheral speed of the rotor of the brush-motor is taken at from 2400 to 5000 ft. per min. Too rapid a speed tends to increase the kinetic energy of the moving parts which does not improve the stability of operation. On the other hand, too slow a speed lowers the specific capacity of the machine, or leads to using too large values for the induction. For good starting action, and the greatest stability of operation, it is preferable to keep the peripheral speed low. For the same reasons it follows that the speed must be reduced in machines of high frequency. The permissible speed of the brushes is governed principally by the consideration of centrifugal forces.

Here is a table giving the commutator speeds and direct-current voltage limits for various poles and frequencies, under given assumptions of design:

No. of Poles	Approximate Diameter of Commutator	Degrees of Pole	Revolutions per Minute	Approximate Comm'r Speed Ft. per Min.	Direct Current Volts
<i>25 cycles.</i>					
2	5 in.	20	1500	2000	300
4	20.5 "	40	750	4000	600
6	46 "	60	500	6000	900
*8	82 "	80	375	8000	1200
<i>40 cycles.</i>					
2	2 in.	8	2400	1280	120
4	7.75 "	16	1200	2600	240
6	17.75 "	24	800	3800	360
8	31.5 "	32	600	5000	480
10	49.5 "	40	480	6400	600
<i>50 cycles.</i>					
2	1.5 in.	5	3000	1000	75
4	5 "	10	1500	2000	150
6	11.75 "	15	1000	3000	225
8	20.5 "	20	750	4000	300
10	31.5 "	25	600	5000	375
12	46 "	30	500	6000	450
*14	66 "	35	430	7000	525
*16	82 "	40	375	8000	600

\*Calculated.

From this table it is seen that, under these conditions of design, the direct-current voltage limit is increased as follows:

At 25 cycles—300 volts for each pair of poles.
" 40 " —120 " " " " " " "
" 50 " —75 " " " " " " "
" 60 " —62.5 " " " " " " "

The brush speeds shown in this table compare favorably with good high-speed commutator practice in this country, as may be noted from the following examples:

On a 1000 kw., 600 volt, 1500 rev. per min., Westinghouse direct-current turbo-generator, the commutator speed is 5100 ft. per min.

On a 1000 kw., 500 volt, 1800 rev. per min., direct-current turbo-generator of another well-known make, the commutator speed is 6220 ft. per min.

On a 150 kw., 125 volt, 2000 rev. per min., General Electric turbo-gen-

erator used as an exciter, the commutator speed is approximately 5200 ft. per min.

The velocity of the collector rings also compares with turbo-generator practice in this country.

LENGTH OF PATH OF FLUX.

The length of the core for one coil is taken as nearly as possible as the fourth of the length of a mean line. The length of the air-gap is about 1/100 of the same. Keeping close to these limits in design it is possible to predict empirically the magnetizing current and the iron losses.

PERIPHERAL AMPERE-TURNS.

In general, the designers consider the normal rated load current as from five to eight times the magnetizing

than at full loads. Thus the efficiency at full load of a 1500 kw. permutator—not yet built—was given as nearly 96 per cent. The calculated power-factor of this same machine was near 95 per cent. The temperature limits were about the same as in standard rotary converter practice.

In Fig. 3 is shown a set of curves giving a comparison between the floor spaces occupied, the weights, and the approximate costs of rotary converters and permutators. This data covers machines for 25 cycles and 250 volts on the direct-current side. The duty that would have to be paid on permutators, if imported, is not included.

A study of these curves will show for capacities ranging from 100 to 2000 kw. that the weights, floor spaces and costs range about as follows:

	Rated Capacity	Approx. Weights		Approx. Floor Space		Estimated Costs	
		Total	Per Kw.	Total Sq. Ft.	Per Sq.	Total	Per Kw.
Permutator.....	100 kw.	2800 lb.	28 lb.	7.1	14 kw.	\$1,800	\$ 8.00
Rotary.....	100 "	6700 "	67 "	22.5	4.5 "	2,300	23.00
Permutator.....	2000 "	37500 "	19 "	59	34 "	10,000	5.00
Rotary.....	2000 "	95500 "	43 "	204	17.7 "	22,200	11.10

These curves indicate a notable economy in space and material in favor of the permutator, though it must be remembered that the comparison is between horizontal shaft rotaries and vertical shaft permutators. It should also be borne in mind that as yet the permutator has not been built in larger capacities than 500 kw., and the parts of the curve lying beyond that point represent only calculated approximations, and not apparatus actually constructed. With all these allowances

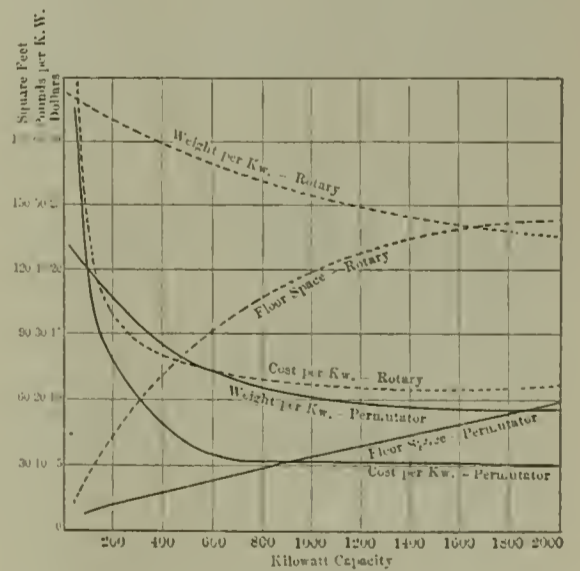

Fig. 3

current. In machines designed for a large overload capacity this proportion would be lessened by a judicious increase in the saturation. Practically, the ampere-turns are about 1250 per in. of perimeter, but can be carried up to 2500 without difficulty.

PERIPHERAL CAPACITY.

From the above constants it may be calculated that the specific capacity in the air-gap varies from 190 to 320 watts per sq.in., which corresponds to an air-gap area of from three to four and one-half square inches per kilowatt.

PERFORMANCE.

The efficiencies of the permutator, according to the published statements of the manufacturers, is always somewhat higher than the efficiencies of a rotary converter of the same capacity. The advantage is greater at fractional

borne in mind, however, the inherent advantages of this type of current-changing machine are most strikingly brought out.

In Fig. 4 is shown a proposed arrangement of an electric locomotive having the same dimensions as those used in heavy railroad work in this country, equipped with a pair of trans-

formers of suitable capacity, tee-connected for three-phase service, and a 2000 kw. permutator for supplying direct current to eight gearless direct-current motors. The voltage of the transformers might be as high as the trolley voltage that could be used while on the low-tension side it would be designed to suit the motors fed through the permutator. It may be

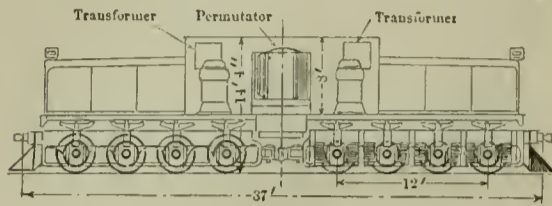

Fig. 4

noted that the ratio of the direct-current voltage to that of the alternating current supply voltage is almost the same for the permutator as for the rotary converter, for the same phase conditions. An electric locomotive, so equipped, would have certain advantages over any direct-current locomotive yet put in commission.

#### ADVANTAGES CLAIMED FOR THE PERMUTATOR.

The manufacturers of these machines claim that they have been given severe tests in service, and that these tests have shown their superiority over other types of rectifying devices. The main points of superiority claimed for them are as follows:

1. Less first cost.
2. Less floor space occupied.
3. Less weight.
4. Less attendance—and less skilled attendants.
5. A simpler starting action—no starting devices necessary.
6. Rapid and automatic synchronization—no synchronizing devices necessary.
7. Absolute stability of operation—cannot fall out of "step."
8. Great overload capacity—momentarily up to from two to three times full load.
9. Efficiencies and power-factors as good as any other types.
10. Perfect operation in parallel.
11. Adaptation to all frequencies.
12. Simplicity and low cost of the few auxiliaries necessary.

If these claims are anything like true it would seem that the permutator really marks an important advance in the manufacture of current-changing machinery. Easy to install, simple to operate, running with a minimum of attention, they would be attractive to all in need of that sort of apparatus, whether for large or small sizes.

In many cases, moreover, where rotary converters or motor-generator sets would be entirely out of the ques-

tion, as, for instance, in the case of a portable substation in a locomotive cab as above referred to, these comparatively light, simple and robust machines would serve the purpose admirably.

#### VARIABLE POTENTIAL PERMUTATORS.

It is understood that the manufacturers of the permutator are perfecting a line of apparatus in which, by means of a movable secondary to the transformer part of the machine, the direct-current voltage can be varied from zero to full voltage. They are also investigating the question of uniting step-down transformer action with the action of the permutator transformer, thus permitting the device to be directly connected to any reasonably high-tension alternating current circuit. It is pointed out, in this connection that the design of the apparatus is such as to readily admit of immersing all high-tension parts in oil. Further developments in this line will be awaited with interest.

#### Electric Furnaces

As a result of the experimental work in iron smelting at Sault Ste. Marie, the Noble Electric Steel Company is erecting a Héroult electric furnace plant for reduction of iron ore at Héroult-on-the-Pitt, Shasta County, Cal. At Newmire, Colo., reduction works have been started by the Vanadium Alloys Company for the production of vanadate of iron and ferrovandium.

The salient features of the several types of electric furnaces which have been used commercially are as follows:

The Héroult electric furnace, as used for the experimental smelting of iron ore at Sault Ste. Marie, Ontario, consists of a short cylindrical stack having a carbon-lined crucible hearth connected with one circuit terminal, and a massive carbon electrode adjustably suspended from above and extending down into the furnace chamber. The carbon electrode used was 16 by 16 inches by 6 feet long and the furnace chamber was approximately 30 inches in diameter.

The Héroult furnace, as used for steel making, is of the tilting, open-hearth type. Two massive electrodes, carried by vertically adjustable supports which are attached to the furnace structure, pass through the roof of the furnace. The current passes from one electrode through an air gap to the slag, through this to the underlying molten metal, thence through the latter and back through the slag and the air gap to the other electrode. It thus forms two arc fields between the slag and the respective

electrodes. The intensity of the current is controlled by regulating the gap between the electrodes and the slag.

The Kjellin furnace, as operated at Gysinger, Sweden, is of the induction type, using a primary alternating current of 90 amperes and 3000 volts and developing in the charge, which is in an annular pocket, a current of 3000 amperes at 7 volts. In its present form the furnace permits of tipping for pouring the charge. The product is an exceptionally pure steel akin to crucible steel.

The Keller furnace for ore smelting is of the resistance type, and consists in general of two or more shafts connected at the bottom by a lateral canal, which widens out midway between the shafts to form a reservoir, or hearth, for the molten metal. Each shaft has a massive carbon electrode extending down from above, and the charge is fed progressively into the shafts around the electrodes. The molten metal is tapped from the reservoir, or hearth, and the slag is tapped from each shaft at a higher level than the reservoir tap.

The Stassano furnace is of the arc type, a 3-phase alternating current being distributed to 3 electrodes which pass into the furnace radially and at an angle inclined slightly downward, and nearly meet in the center above the charge, which is not in circuit. The furnace, its hearth being of a crucible form, stands with its vertical axis inclined about 7 degrees from the vertical, and when in operation the whole furnace is rotated to mix the charge and subject all parts thereof to a uniform heat.

Certain results, as given in the report of the Canadian commission on the electric smelting of iron ores, are as follows: Pig iron (gray iron) to the amount of 11,989 pounds was produced from magnetite ore (55.85 Fe), with charcoal as the reducing agent and limestone and sand as flux, at the rate of 9.92 short tons of pig per 1000 electric horse-power days. The power used was 221.34 electric horse-power (mean amperes, 4987; mean volts on furnace, 36.03) and the length of the run was sixty-five hours and thirty minutes. It is stated by Doctor Héroult that an output of 12 tons of pig iron per day may be obtained with 1000 electric horse-power. On a run on roasted pyrrhotite (45.80 Fe), with charcoal and limestone as above, there was produced 7336 pounds of ferro-nickel pig at the rate of 7.038 short tons per 1000 electric horse-power days. The power used was 222.05 electric horse-power (mean amperes, 5000; mean volts on furnace, 36.05) and the length of the run was fifty-six hours and twenty-nine minutes.

# Current-Surge in Closing an Inductive Circuit

By J. E. FRIES

Associate A. I. E. E.

MOST electricians are familiar with the surge of current which takes place when a transformer or an induction motor with open secondaries is thrown in on an alternating-current system. It is felt as a sudden "jar" in the machine and a violent deviation of the ampere needle. This phenomenon has assumed a more and more serious character with the construction of motors and transformers where the iron is worked to a higher saturation, as in later years increasingly has been the case. It has gone so far that the safety devices or automatic circuit-breakers, although adjusted for a current above the normal, have operated and opened the circuit the moment it was closed through an unloaded motor or transformer, *i.e.*, through a machine with open secondary. To diminish the effect of this surge it has been found necessary to provide the closing switch with an extra contact, introducing at first a resistance, which of course in the next moment is short-circuited.

The more serious effects of the surge have in this way been mitigated and although I have no better remedy to propose, yet I believe that the causes and influential factors of this phenomenon have not hitherto been very closely investigated and that therefore the following discussion may prove of some value.

I wish then first to remind of a

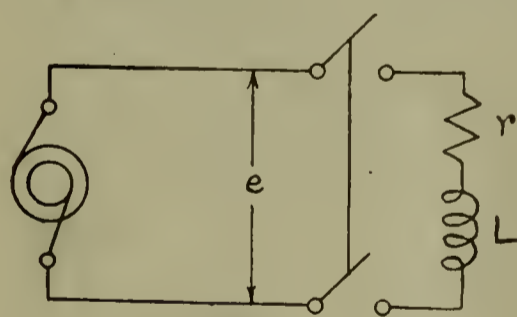

Fig. 1

phenomenon intimately connected with the present, that is the surge, taking place at the closing of a circuit, containing an induction coil without iron-core, and therefore with constant coefficient of self-induction. If such a coil with the resistance  $r$  and the coefficient of self-induction  $L$  is connected between two points with a potential difference  $e$  (Fig. 1) the following relation obtains between these

quantities:  $e = ri + L \frac{di}{dt}$ , where  $e$  and  $i$

are the momentary values of voltage and current at the time  $t$  after closing

the circuit. If now  $e$  varies harmonically or as a simple sine-function, as we may assume in an ordinary alternating system, we may write:  $e = E \sin \omega t$ , where  $E$  is the amplitude of the electromotive force and  $\omega$  the angular velocity, that is:  $\omega = 2\pi \nu$  where  $\nu$  is the frequency.

The differential equation then becomes:

$$\frac{di}{dt} + \frac{r}{L} i = \frac{E}{L} \sin \omega t;$$

And its solution:

$$i = \frac{E}{\sqrt{r^2 + L^2 \omega^2}} \sin(\omega t - \phi) + C e^{-\frac{r}{L} t} \quad (1)$$

where  $\tan \phi = \frac{L\omega}{r}$  and therefore

$$\sin \phi = \frac{L\omega}{\sqrt{r^2 + L^2 \omega^2}}; \text{ as further } t=0$$

when  $i=0$  our integration constant becomes:

$$C = \frac{L\omega}{r^2 + L^2 \omega^2} E.$$

Inserting these values in 1, we obtain:

$$i = \frac{E}{\sqrt{r^2 + L^2 \omega^2}} \left[ \sin(\omega t - \phi) + \frac{L\omega}{\sqrt{r^2 + L^2 \omega^2}} e^{-\frac{r}{L} t} \right];$$

For the problem that interests us here  $r$  is entirely insignificant in comparison with  $L$  and our equation may therefore be written:

$$i = \frac{E}{L\omega} \left[ \sin\left(\omega t - \frac{\pi}{2}\right) + e^{-\frac{r}{L} t} \right] \quad (2)$$

Thus we see that the current has two components, one simple harmonic and one logarithmically decreasing towards zero. Graphically this is shown in Fig. 2.

In the case here assumed, when the circuit is closed at  $e=0$  and  $e$  changing from negative to positive values, the current commences with predominating positive values and with an amplitude that is twice the normal and only gradually becoming normal and symmetrical as the common alternating current. If contact is made when  $e$  changes from positive to negative, the current commences negative but the phenomenon is otherwise the same.

The time required for the current to become practically normal depends on the quotient  $r:L$ . If in equation (2) the

$$\text{time } t = \frac{L}{r} \text{ then } e^{-\frac{r}{L} t} = e^{-1} = 0.37$$

that is after  $\frac{L}{r}$  seconds the "one-sided" component has decreased to 37 per cent. of its original value.

For coils without iron core the maximum practicable value of  $\frac{L}{r}$  (the so-

called time-constant) is about 0.5. In closing the current through such a coil under conditions mentioned it requires therefore half a second before the eccentricity of the current-curve has decreased to one-third. At a frequency of 60 this time corresponds to 30 whole cycles.

It might be of interest to calculate the effective value of the current during these first moments in order to see if the surge might be able to ruin an ampere meter of the "Hitzdraht" type introduced in the circuit. The effective current  $I$  according to its definition is:  $I^2 = \frac{1}{T} \int_0^T i^2 dt$  where  $T$  is the time for one complete cycle.

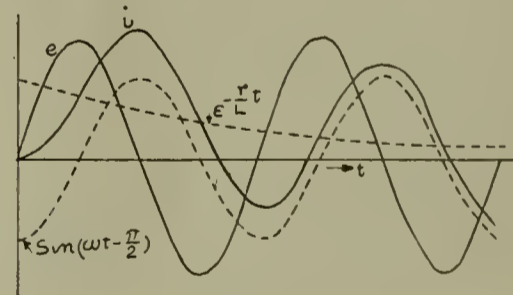

Fig. 2

Inserting this value in 2 and integrating for the first cycle that is, as-

suming  $t$  so small that  $e^{-\frac{2r}{L} t} = 1$ ,

we obtain approximately  $i_0^2 = \frac{3}{2} \frac{E^2}{L^2 \omega^2}$  for the first cycle, or:

$$i_0 = \frac{E}{L\omega} \sqrt{\frac{3}{2}};$$

When  $t$  is great, that is, when we have reached normal conditions we have, as is well known:

$$i^2 = \frac{1}{2} \frac{E^2}{L^2 \omega^2} \text{ or } i = \frac{E}{L\omega} \times \frac{1}{\sqrt{2}}$$

During the first cycle, therefore, the current is  $\sqrt{3}$  times greater than normally. On the other hand the heating effect is proportional to the square of the current so that this effect during the first cycle is three times the normal. When the time-constant is great the current-surge *might* therefore be ruinous to the ampere meter.

If we assume the switching to take place a moment when the electromotive force differs from 0 we shall find less eccentricity of the current-curve, and if it happens when  $e$  has a maximum value the current becomes normal from the beginning.

If we in (1) put  $i=0$  when  $\omega t=\phi$  or  $t=\frac{\phi}{\omega}$  we obtain  $C=0$  and therefore the current is simple harmonic all the time.

When the coil is provided with an iron core the conditions are changed, because the coefficient of self-induction no longer remains constant and we might therefore obtain a current surge considerably larger than we should have expected from the previous considerations. As the coefficient of self-induction now is variable, we cannot find a simple analytic expression for the current and we shall therefore treat the problem graphically.

Assuming a harmonically changing magnetic flux in an unloaded transformer, we know that the electromotive force induced in the winding is:

$$e_i = -N \frac{d\Phi}{dt} \quad \text{where } N = \text{number of turns; or if } \Phi = \Phi_{\max} \sin \omega t$$

$$e_i = -N\omega\Phi_{\max} \cos \omega t = N\omega\Phi_{\max} \times \sin \left( \omega t - \frac{\pi}{2} \right).$$

The induced electromotive force therefore lags behind the flux 90 degrees. If the resistance is comparatively small it may be neglected in this connection and we may assume that the impressed electromotive force or the electromotive force between the terminals has the self-induction alone to balance. Therefore, the terminal voltage  $e_t$  is 180 degrees ahead of  $e_i$  or

$$e_t = N \frac{d\Phi}{dt} = N\omega\Phi_{\max} \sin \left( \omega t + \frac{\pi}{2} \right) \dots 3$$

which is graphically represented in Fig. 3 and holds good under normal conditions. During the time 0 to  $\frac{T}{2}$  the terminal voltage  $e_t$  is positive and increasing from  $-\Phi_{\max}$  to  $+\Phi_{\max}$ , following the law, that the ordinate to the  $e_t$ -curve in every point is proportional to the tangent in the corresponding

point on the  $\Phi$ -curve. If we know the conditions in the core we may now easily determine the current  $i$  necessary in each point to produce the corresponding flux. The quotient  $\frac{\Phi}{i}$

which is proportional to the quotient  $\frac{B}{H}$ , if the core has no air gap, is shown in Fig. 3 and the  $i$ -curve has there been plotted and drawn.

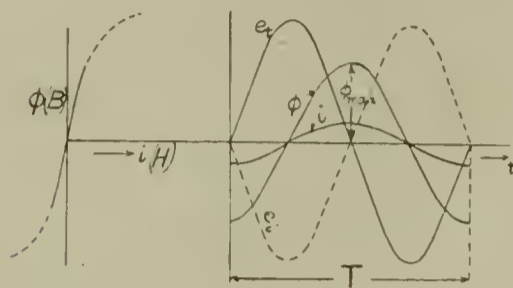

Fig. 3

As the B-H curve is shown as a single line, assuming the iron without hysteresis,  $i$  is in phase with  $\Phi$  or 90 degrees towards  $e_t$  and consequently the effect of the no-load current equals 0.

In reality a phase displacement exists between  $i$  and  $\Phi$  on account of hysteresis and might easily be determined from the actual B-H curve. For the same reason the actual phase difference between  $e$  and  $i$  is in reality less than 90 degrees and the no-load effect has a value, differing from zero. In the present connection, however, we may disregard this discrepancy.

If we now imagine that the impressed electromotive force is switched on at the time  $t=0$  in Fig. 3, that is when  $e$  changes from negative to positive values, and that the iron core is magnetically neutral (or very nearly so) then the current wave will differ materially from running conditions.

We find that  $e_t$  is normal as before and  $\frac{d\Phi}{dt}$ , therefore, according to equation (3) of same shape as in Fig. 3.

only the curve commences in zero and has all the time a value which is the normal one increased with  $\Phi_{\max}$  point for point. Its new maximum value, then, is twice the normal maximum value. This second curve is shown in Fig. 4 and the corresponding current curve  $i'$  plotted and drawn as before. For common B-H curves it will be found that the normal maximum induction ( $B_{\max}$ ) in a transformer must reach 8000 to 9000 only in order to 10-fold the initial current. For a normal  $B_{\max}$  of 10,000 to 11,000 the current surge might amount to 50 or 100 times the normal current and so on in rapidly increasing progression.

If the switching takes place a mo-

ment when  $e_t$  differs from zero we find as before that the surge becomes less marked the more we approach the time for maximum terminal voltage, and if the circuit is closed at that very point, the current is normal from the beginning.

We must, however, remember that the iron core on account of resident

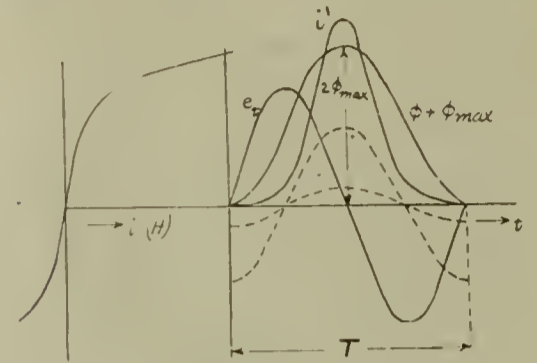

Fig. 4

magnetism is not actually neutral as assumed above when  $e_t$  is zero. The surge might therefore perhaps be smaller but it might just as easily be more pronounced than before. As the resident magnetism increases with decreasing air gap we must take this quantity also into consideration. Generally speaking, transformers have smaller air gaps than induction motors and the resident magnetism is therefore of more importance with the former than with the latter class of apparatus.

Knowing the hysteresis curve (B-H; curve in Fig. 5) and the ratio between the air gap  $\delta$  and the iron  $l$  in the magnetic circuit, we can determine the resident magnetism ( $B_r$ ) and therefore understand how it influences the current surge in different cases.

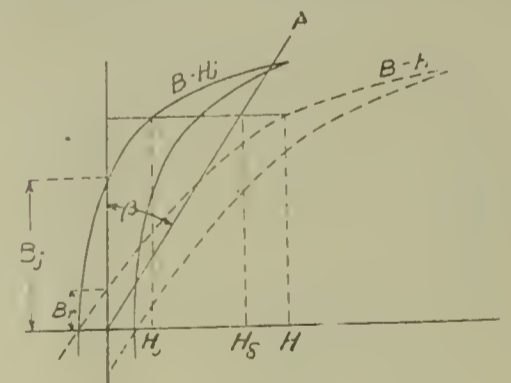

Fig. 5

For a certain B we have:

$$lH = lH_j + \delta B \quad \text{or} \quad H = H_j + \frac{\delta}{l} \times B (= H_j + H_\delta);$$

The line OA in Fig. 5 is drawn under an angle  $\beta$  such that  $\tan \beta = \frac{H_\delta}{B}$ . Adding the abscissas of this line to corresponding abscissas of the H-H<sub>j</sub> curve we obtain the new hysteresis curve B-H where then  $B_r$  is the true resident induction for the circuit in question.

Assuming ordinary transformer and motor plate I have approximately calculated the residuent induction for different ratios between lengths of air gap and iron path in magnetic circuits under the further suppositions that the maximum induction amounts to 12,000 to 17,000 and that the cross section is constant throughout the magnetic circuit. The result is shown in the following table:

$\delta:l$	Br
0	10000
0.0002	5000
0.0004	3300
0.001	1700
0.003	630
0.01	200

As the ratio  $\frac{\delta}{l}$  cannot very well be less than 3:1000 in motors, we see that the residuent induction does not amount to 1000 and is therefore of little consequence as regards the current surge. This may nevertheless be worth our attention if only the maximum induction in any considerable part of the circuit amounts to 10,000 or more. In the teeth we often have a maximum induction of 15,000 and even more and this is sufficient under favorable conditions to cause a serious surge.

In transformers the ratio  $\frac{\delta}{l}$  is much smaller and with laminated cores nearly 0. Hence it is evident that the residuent magnetism here is of greater importance and might occasionally give rise to troublesome surges.

The time required to reach normal conditions depends again upon the quotient  $r:L$ . This is, however, now difficult to calculate partly because  $L$  is not constant and partly because  $r$  is made up not only of the winding resistance but also of the iron losses. Both  $r$  and  $L$  vary very irregularly with the induction and the current so that neither can be expressed analytically in a simple way. The time, therefore cannot be exactly calculated, but might possibly be estimated fairly well in each particular case.

It has increasingly been found necessary in practice to take this current surge into account. As already said before the remedy nearest at hand is the introduction of a temporary resistance which subsequently is short-circuited. The question then arises whether this resistance should be inductive or not. Without entering into details I would point out as my opinion that the non-inductive resistance should be chosen; not mainly because it may be built cheaper, but be-

cause it will serve to make the surge less protracted in as much as the time-constant evidently becomes smaller.

From the considerations given above to the causes of the current surge in question it is obvious that high induction in the iron of the transformer or of the motor is the most important one. Because a low frequency, as is well known, allows a higher induction such frequency has the disadvantage of aggravating the surge. The new silicon iron, which on account of its low hysteresis constant and high specific resistance more and more is used in transformer cores, allows a high induction, and as its permeability is not much over the ordinary, it has a marked tendency to produce serious surges. In spite hereof the induction and therefore the surges have been still further increased lately through constructions made possible only by the employment of more effective cooling arrangements. These circumstances combined probably account for the fact that the current surges in question hitherto have been given so little attention and study.

It is evident from what we have said above that this surge has nothing to do with the rise of voltage observed at the same occasions. Although the remedy sometimes is the same the causes are entirely different. I would even go so far as to say that the current surge is more serious and more apt to appear at low than at high voltages. When the electromotive force is high a spark often closes the circuit before metallic contact is made and this evidently is most apt to happen at the maximum point of the voltage wave when no current surge takes place at all. But at low voltage no current is established before metallic contact is made and the surge may therefore come into play at any point of the voltage wave.

#### Electrical Work in India.

Counsel - General William H. Michael, of Calcutta, submits the following openings in India for electrical engineering:

The little city of Poona is situated 45 miles from Bombay at an elevation of 1800 feet above sea level. It is a week-end resort for many of the well-to-do citizens of Bombay, who have fine cottage homes there, or have reserved suites of rooms at the hotels and boarding houses. It is rather a fashionable hill suburb of Bombay. It has all sorts of accommodations for sports and a race course that is considered equal to any in India, which boasts of many of the finest mile courses in the world.

The latest scheme for improvement

at Poona is an extensive electric-car system. A Bombay firm has made a start with a scheme to provide Poona with electric light for streets, power and cars. The supply, at first, is to be confined to the municipal limits of Poona, and this area enlarged as the demand requires. It is proposed to supply the energy from a central station, and to lay underground mains, or to erect overhead wires, as may be approved by the local government. All the streets to be supplied are under control of the municipal government, but it is already understood that there will be no opposition by government to the proposed scheme.

No country stands as well in India as America in regard to all kinds of electrical machinery and supplies, as well as to methods in the use of them. American electrical engineers are here considered the best in the world, and I would modestly suggest that they pay some attention to the Poona proposition.

The extensive electrical works in Kashmir, under the direction of American electrical engineers, are making rapid progress toward completion. The power is derived from the Jhelum River, below Baramulla. The big flume, capable of carrying 20,000 horse-power, is completed, and the turbines to furnish 5000 horse-power are being installed. Electrical power for mills and other purposes will be conveyed to Serinagur, many miles away. The scheme for extending the power is a large one, and great commercial results are confidently expected. The comfort and convenience that will necessarily follow to a large territory occupied by millions of people would be hard to describe. The items of lighting and operating electric fans alone are worth the expenditure on this great enterprise.

#### The Welsbach Mantle.

The light distribution curves of the various incandescent units are all practically the same, and it is not necessary to discriminate. The distribution curve of light from the welsbach mantle is very similar to that of the incandescent unit, with the exception that there is slightly more light above the horizontal in the case of the welsbach mantle. In many cases the increase in light in the upper hemisphere is exaggerated by the shape of the mantle itself, which is somewhat conical. Unless the welsbach street lamp is furnished with a suitable reflector, the light flux above the horizontal is practically wasted and the relative illumination efficiency of the lamp is reduced.

# Underground Construction

H. B. Gear, General Inspector Commonwealth Edison Co., Chicago, and P. F. Williams

THE use of underground construction has been general in the larger cities from the beginning of the electric lighting industry. Considerations of appearance and space prevented the use of overhead lines in the congested parts of the cities where the first market for electricity was found. The greater first cost was found to have been well justified in the increased security to important consumers who required continuous service and to whom an interruption meant financial loss. The development of many of the large city systems proceeded at such a rate that in any event overhead construction would have become physically impracticable on account of the number and size of the feeders which were required to supply the network.

The underground system devised by Edison was the earliest one to be commercially adopted, and much of this class of equipment is still in service, though other methods are now preferred. The Edison system remained standard for low-tension distribution for about 15 years and was in many ways an admirable plan of distribution. It consisted of 20-ft. lengths of iron pipe, inside of which there were copper rods imbedded in a bituminous compound, which was designed to exclude moisture, and to insulate the opposite polarities from each other and the pipe. The rods were wound with a wrapping of jute to prevent their sagging together, and are further held rigidly apart by separators at the ends. These 20-ft. lengths were made in various sizes of conductor up to 500,000 cir. mils for mains and up to 1,000,000 cir. mils for feeders.

The Edison Company adopted what became known as the Edison wire gauge for their product. This gauge specified the number of thousands of circular mils in the conductor. The pipe with its conductor was called a tube and a piece having conductors of 250,000 in mils was called a 250 tube, or a tube with No. O. B. & S. conductor was called a 100 tube. Such a gauge became necessary because much of the output was larger than the largest size of any existing standard wire gauge.

Sections of tube, which were designed for use as distributing mains, were made with three conductors of the same size, while those designed for feeders were made with one conductor about half the area of the other. This small conductor was connected in as the neutral.

Feeder tubes were also provided with three small wires, which served as pressure wires to indicate the feeder end pressure at the station or substation.

The sections of tube were laid in the ground without other protection than would be given water or gas pipes. The copper rods were joined by means of soldered lugs with a stranded flexible connector. These connections were enclosed in cast-iron couplings, shown in Fig. 1, which were filled with hot compound after being bolted in place on the tubes. At intersections the tubes were interconnected through junction boxes, which carried the necessary fuse clips and nuts by which a main was automatically disconnected in case of break down, or could be opened by repair men for testing purposes. These boxes were made so that 4, 6, 8 or 10 tubes could be brought together in one box, as was necessary at the intersection of two streets where a feeder was tied in, and where there were lines on both sides of each street.

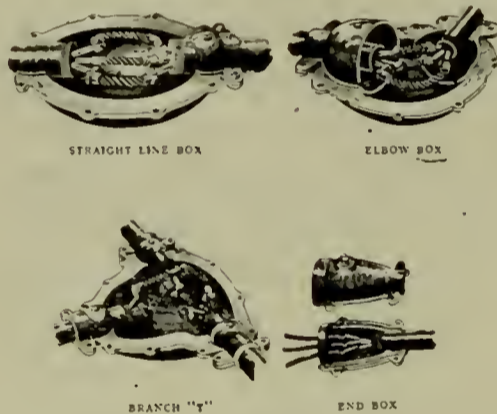

Fig. 1—COUPLING BOXES

Lines were carried along each side of the street near the curb in order to facilitate the introduction of services into consumers' premises. A single line was run where the consumers were scattered and where the alleys were used. Service connections were made by a T connection applied at any joint in the line. The service tube is carried through the building wall into the sidewalk area or into the basement of the building. Where the buildings do not come to the property line, the service is extended across the consumer's premises underground or brought up on a pole at the lot line and carried thence overhead to the building. The expense of the line across the private property is usually borne by the consumer, and the decision as to the method of installation commonly rests with him in such cases.

The Edison tube system was the standard method of distributing low-

tension current underground until about the year 1897, when cables drawn into ducts began to be employed for heavy feeders. This change was made on account of the inability of the tube feeders to carry overloads without melting the compound in the joints and causing burn-outs. With cable it was found that the copper could be run with heavier loads, and therefore more economically from an investment standpoint.

The necessity of opening street pavements in each case where repairs were made involved considerable expense, as several openings were usually made before the trouble could be definitely located.

The feeder system and the heavier distributing mains were therefore gradually worked over to a cable system as rapidly as reinforcement was needed from year to year. The systems, as they exist, therefore embody a combination of cable and tubework. The tube system is not being generally extended at the present time, but on side streets where no through lines are required and the load is not heavy, the simplicity of the tube system is retained by laying a single 3-in. iron, or bituminized fibre duct, into which lead-covered cables are drawn.

Service connections are made in a manner similar to the tube services, the joints being enclosed in a T coupling box of iron. The cost of such construction is about the same as that of Edison tube work, and it is therefore supplanting Edison tubework in cases where such construction is desirable.

The early alternating and series arc systems, which were installed in situations requiring underground constructions, were unable to use a system similar to the Edison tubes, because of the higher voltages employed. They were therefore compelled to seek other means of installing their conductors. A variety of materials was tried, but the method was that of a draw-in conduit system with manholes for handling the cables in nearly every case. One of the earliest was the Dorset system, which consisted of sections of multiple duct made up of an asphaltic concrete and joined together by pouring hot compound around the joints. These joints failed to remain in alignment when settlement took place, and the work of installing cable therefore became difficult, if not impossible.

Wooden pump log was next tried because of its ease of jointing and low cost. It was very satisfactory for



some classes of work, but was too short-lived for important lines, and took fire too easily in case of failure of cable, the creosote with which it was impregnated being very inflammable.

Paper tubes impregnated with bituminous compound were tried in some cases. These were laid in asphalt and the conductors were drawn in without insulation. It was expected that the insulation qualities of the paper tubes would be sufficient to be practical. The presence of moisture, however, could not be avoided, and the tubes therefore absorbed water, which caused the conductors to become short-circuited and burn out. It was practically impossible to make repairs, and the system failed.

In another plan the bare conductors were drawn through 1-in. holes in a wooden tube, which was surrounded by an iron pipe and immersed in oil. The manholes were also kept partly filled with oil to cover the ducts, but as moisture could not be excluded, and the difficulty of adding to or repairing high-tension conductors was great, this system failed.

Other systems were developed in which the ducts were intended to provide insulation for the conductors, but experience proved that it was not at all practical to maintain such a system, and all attempts were finally abandoned.

The efforts of engineers then began to be directed to systems in which the construction was more nearly fireproof, was of greater durability, and was economical to construct and maintain.

This led to the development of methods in which the insulation was applied to the conductor and the conduit was of some fireproof material which would be durable underground.

Among the earlier forms of duct of this sort was one which consisted of sheet-iron tubes lined with cement. It was made in 4-ft. lengths with ferrules at the ends to preserve the alignment, and when properly laid, obviated many of the difficulties experienced with the earlier forms of duct. A considerable amount of it was installed in some of the larger cities. Where it has been subjected to cable burn-outs with large power behind it, it has been found, however, that the cement does not hold up under the heat of an arc, and that the metal sheathing is apt to assist in the spread of the short-circuit. The use of this form of conduit has therefore not been continued in recent years.

As an improvement over this type, a conduit made entirely of concrete, and known as stone pipe, was developed. This was made in 4-ft. lengths and jointed with metal ferrules, single

duct only being used. The conduit line was laid in concrete, making a solid and durable duct system. The cost was about the same as that of other forms of construction, but the concrete pipe in 4-ft. lengths was so fragile that the breakage was excessive. This was due in part to the fact that the pipe did not acquire its full strength and hardness until it had been seasoned 60 days or more after being molded. This necessitated large storage facilities if carried out and considerable capital tied up in stock. The excessive breakage resulted largely from the attempt to work with unseasoned stock, and as the capital required was excessive, this form of conduit has found but limited application.

While these various forms of duct were being tried out, other engineers were introducing ducts of terra cotta and clay tile. These materials are fireproof and of indefinitely long life, and it only remained to work out the best form of duct and the most durable way of laying it. Multiple and single duct was tried and the alignment and security from outside interference was gotten by protecting the ducts by concrete or creosoted plank. The supply of clay was abundant, and the expense was therefore somewhat less than with other ducts. The demand soon became such that other forms of duct could not have well furnished the necessary supply. This class of construction is now therefore the most generally used in distribution work where a drawn-in system is employed.

In the design for a draw-in tile duct system, the number of ducts, the size of manholes and their location are important considerations.

The number of ducts must be fixed by the particular requirements of the route to be followed. There must first be sufficient to care for the local distribution, next for distributing feeders, next for transmission lines and next for possible future requirements. The distributing mains for a low-tension direct-current system usually fill one duct, with alternating mains and underground secondaries, two ducts must be reserved in many parts of the system. The feeder and transmission line requirements are usually well known. The reservation of duct space for future requirements is very important if the system is a growing one, as the expense of adding a few ducts at a later date is much larger than if they are laid when the trench is open. It is therefore desirable to lay sufficient reserve ducts in advance to care for probable requirements for about five years ahead. It is not advisable to lay less than four ducts in a line, except on side streets where there is no probability that the

line will ever become part of a through line. In such cases a two-duct line is installed, except where a single pipe with a low-tension main will meet the requirements.

The maximum number of ducts which it is advisable to put into a line is governed somewhat by the local conditions, but chiefly by considerations of safety to the cable equipment. The space available on walls of manholes for training cables is limited, and if more than 20 or 25 ducts full of cable are carried through a manhole a large part of the load of the system may be endangered by a failure on any one of the cables. The security of the service as a whole is much improved by having conduit lines subdivided sufficiently to prevent a complete interruption of service in case of a serious manhole burn-out, or an accident to the conduit system. Where conditions are such that a very large line must be used, a measure of protection may be had by separating one-half of the duct line from the other by a 6-in. concrete barrier and building double manholes for two sides of the line with an 8-in. brick partition through the middle of them. A line having more than four ducts in each layer is to be avoided where possible on account of the difficulty of properly training the cables. The arrange-

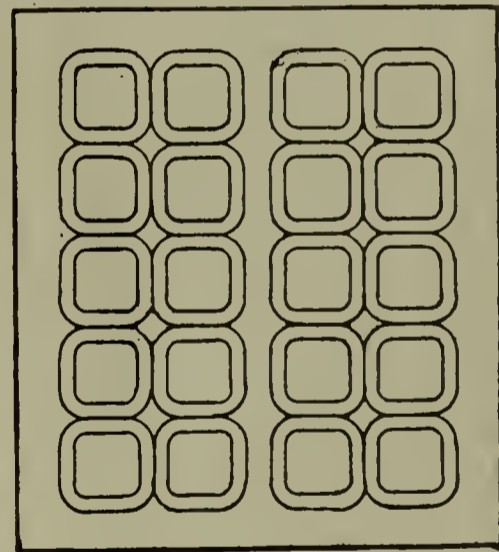

Fig. 2

ment of ducts shown in Fig. 2 is a desirable one where more than 16 ducts are laid in a line.

The use of a draw-in system involves the construction of vaults called manholes at all points where the cables must be jointed or where lines change direction.

Where long runs occur without intersecting other lines, manholes must be provided with sufficient frequency to permit the drawing in of cable without overstraining the cable insulation. This usually requires that they be not over 500 ft. apart and with large cables which nearly fill the duct 400 ft. is a safer limit.

The location of manholes on a length of line which is not intersected

by other duct lines at each block should be made, as far as possible, with a view to their being used as intersection points later. That is, they should be located so that any conduit line built on an intersecting street later may be connected with existing manholes. It is impossible to predict with certainty which side of an intersecting street will be used, but the location of manholes at street and alley intersections will minimize the necessity for duplication. Where distribution by overhead lines in alleys with underground lines on the street is used, manholes should be put opposite alley intersections where it is necessary to locate them between streets. It is also advisable in such distribution to locate manholes opposite alley intersections where lines are likely to be connected from the duct system to the pole system at some future time.

The number of manholes required in blocks where numerous underground service connections are required is dependent somewhat upon local conditions, but must usually be sufficient to enable lateral pipes to be brought in to sub-sidewalk areas, or basements, at intervals of 25 to 100 ft. In the denser portions of the system, this results in the location of small manholes at intervals of 75 to 125 ft., while in other parts they may be 150 to 200 ft. or more apart. In distribution by means of underground transformers and a secondary network where the load is dense, it may, in some cases, be necessary to build extra manholes for the transformers in order to get sufficient room and proper ventilation.

The size and shape of manholes are varied to suit the requirements in different situations. Manholes located in a straight-away line should be so designed that the cables may be trained around the sides with a minimum of waste cable and yet with sufficient space to enable a jointer to work efficiently. Such a manhole is illustrated in Fig. 3. The oval shape permits of easy training of cable, and the width of 4 ft. is ample to allow the jointer room to work with any number of ducts up to nine. Where the line turns a corner or intersects another duct line, a design must be used which gives room for cables going both ways and which will afford room for work as well. At such points a square design is preferable, as shown in Fig. 4. The smallest size ordinarily used for such places is 5 ft. square. Where many cables are involved or where room is required for low-tension junction boxes or transformers, dimensions of 8 by 8 in., or larger, are often necessary. Where it is likely that many

splices will be made or other work of construction or maintenance done frequently, it will be found to be most economical in the long run to provide manholes of ample size for convenient working space. The money saved by reducing the dimensions of a manhole may easily be spent several times over in extra cost of work done on cables in the manhole in later years.

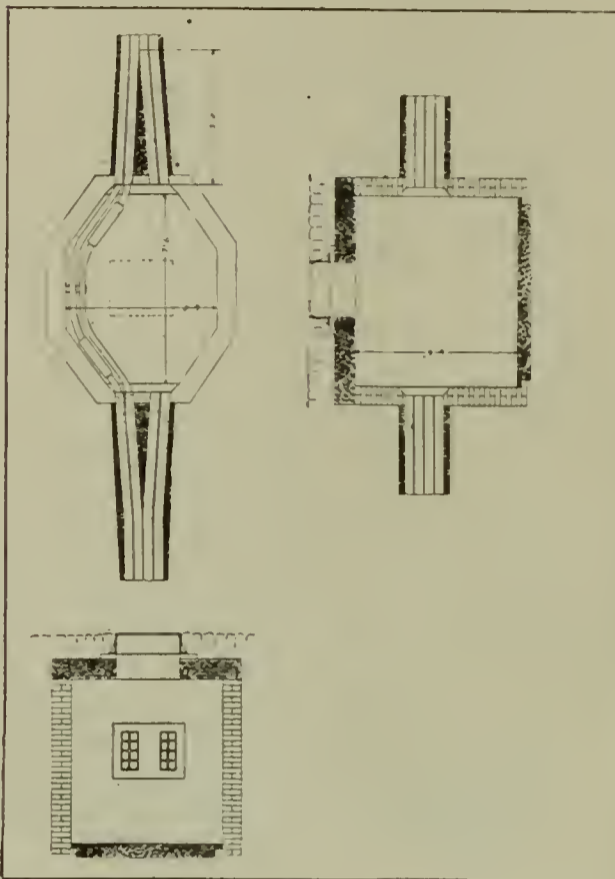

Fig. 3

In a growing system it is a matter of judgment as to what the requirements in the way of space are likely to be. The space required for cables is fixed by the number of ducts coming into the manhole, and this must be sufficient to allow of training these cables safely and with a reasonable degree of accessibility for repairs or changes. The probable installation of junction boxes or transformers must be taken into account also. In practice it is usual to provide manholes 5 by 5 ft. at junctions where there are eight ducts, that is, where two 4-ft. duct lines cross, 6 by 6 ft. where there are 12 to 18 ducts, 7 by 7 ft. where there are 20 or more and larger as the needs of the case may require.

The size and shape of manholes in congested districts is often governed by local obstructions, such as gas or water mains and services or the conduit lines of other public service companies. Manholes must frequently be built so as to include a gas main and the size must be increased to get the necessary space.

The depth of manholes must be sufficient to give head room, and yet should preferably not be so great as to carry the floor of the manhole below the sewer level. Small distribution manholes, which are used only for

service connections, may be more shallow than larger holes where work is done frequently. Service manholes may be 4 or 5 ft. inside, while junction manholes should be 6 or 7 ft. from roof to floor. In some cases a shallow form of manhole, known as a handhole, is used for distribution laterals. These are made about 3 by 3 and 3 ft. to 4 ft. deep. They are placed above the conduit line so that only the top row of ducts enters the handhole. The distributing mains are thus accessible for service taps, and the through lines in the lower ducts are not in the way. Service laterals are usually laid just under the surface, so that they enter the handhole at a convenient level. Handholes should have covers large enough to afford access to the distributing main.

The arrangement of service laterals or subsidiary connections from the main duct line to consumer's premises is a matter of much importance, as it forms a large part of the underground investment in congested districts. Local conditions often fix the character of the design, so that no universal method can be laid down as better than all others. In some cities a separate service lateral is not required for each building into which service is to be introduced and the laterals may be placed at intervals of 75 to 100 ft. or more, the intermediate buildings being connected by means of interior wiring through sub-sidewalk areas or building basements. This method is much less expensive than that required in other cities where each building must have its own service connection, as it requires less distributing handholes or manholes and a much less mileage of lateral pipe and service cable.

Where service laterals can be spaced 100 ft. or more apart a single duct line is sufficient to care for the service on both sides of the street. Lateral connections are run to each curb or building line from the service manholes. With a street more than 100 ft. wide, it might be more convenient to use two duct lines to save the long laterals. In very congested districts it is advisable in this class of construction to put in double laterals each way to facilitate repairs or changes in the cable work, or to give emergency service to important consumers.

Where separate service is required for each building this plan may result in the installation of manholes or handholes at intervals of 50 ft., as in Fig. 5, where buildings are on 25-ft. lots and service is required in nearly every building. In such cases, it is less expensive in the long run to establish service handholes at intervals of about 100 ft. on each side of the

street. The arrangement shown in Fig. 6 is the result worked out in a street 70 ft. wide, with 40 ft. between curb lines. This arrangement requires less lateral cable and pipe and is the most feasible arrangement in streets where there are car tracks under which laterals must be carried. The advantage of the construction shown in Fig. 6 increases with the width of the street. It is also an advantageous plan

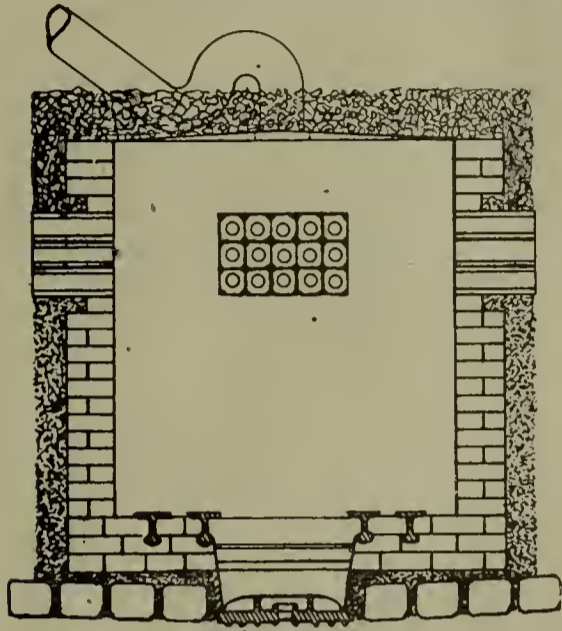

Fig. 4

where there is a parkway in which the laterals can be laid, no paving being disturbed except for the one street crossing.

In the location of a duct line the presence of other piping systems, duct systems, sewer manholes and the like, must be taken into account. It is desirable to select the side of the street which is least obstructed by such obstacles. The municipal records should be consulted to get the location of the piping and sewer systems, if such records are kept in available and accurate form. Other duct systems are readily located by the manhole covers which appear on the surface. In crowded streets and where records are not available, time is sometimes saved by excavating a test trench across the street at several points for the purpose of locating the piping and other systems which cannot be identified from the surface.

Tile duct is made of clay which is worked up in a pug-mill to the proper consistency, passed through a press from which it emerges in the desired shape, carefully dried and burned in a kiln until it is thoroughly vitrified. It is then given a salt glaze and allowed to slowly cool.

The quality of the duct is affected by many of the processes very materially, and it is therefore important that it be purchased under careful specifications. Some of the more important points follow:

The clay should be of such composition that it will be free of gravel and

will work up into a solid homogeneous mass; 60 per cent. fire clay and 34 per cent. shale make a very desirable combination.

The duct when molded and dried should be burned through, but not scorched or fused. The glaze should thoroughly cover the inside of the ducts so that they will present a smooth surface to the cable.

Single duct should not have a bend of over  $\frac{1}{8}$  in. from a straight line and multiple duct should not have a more

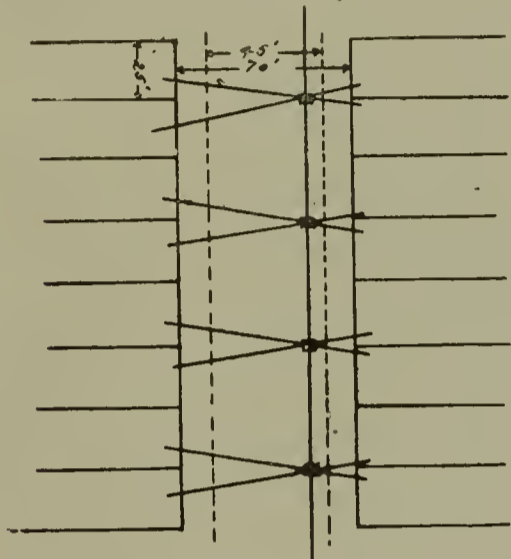

Fig. 5

than  $\frac{3}{16}$ -in. bend. Twisted or distorted pieces should be rejected, as they cannot be lined up and may interfere with rodding the duct.

No duct having salt-blisters or drips which project more than  $\frac{1}{8}$  in. inside or  $\frac{1}{4}$  in. outside should be used.

Air- or fire-checked pieces should not be accepted.

The test for straightness should be made by passing a mandril of the

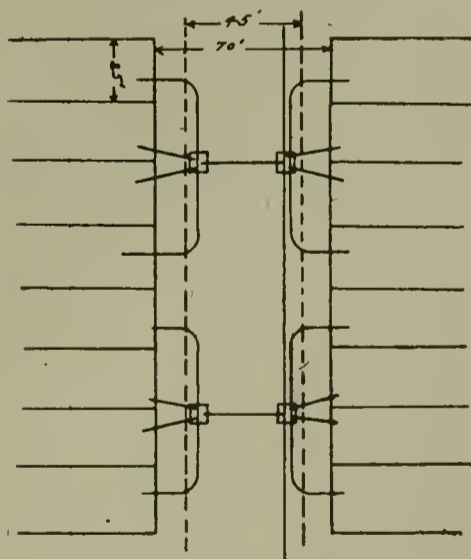

Fig. 6

length of the piece and  $\frac{1}{8}$  in. smaller than the inside of the duct through it. If the mandril will not pass, the duct is too crooked to be safely installed.

If the tile is properly vitrified it will give a clear ringing sound when struck with a piece of tool steel  $1\frac{1}{2}$  by  $\frac{3}{4}$  in. If not, it gives a dead sound, which indicates softness and porosity, which will result in too high

a rate of breakage in handling if accepted.

The conduit is made in single or multiple duct pieces. Single duct pieces are usually about 18 in. in length, while multiple duct may be made 36 in. long. The greater length is desirable in reducing the labor of laying, but is not practicable in single duct on account of breakage. The dimensions of ducts in general use are shown in Fig. 7. The duct having a square hole is preferable, as cable may be pulled into it easier. Multiple duct is somewhat cheaper than an equal number of single ducts, as it requires less labor to lay it. In a large system with the danger of injury to the duct line when an arc is maintained in the duct, it is usually considered preferable to use single duct to secure the advantage of having two thicknesses of tile between adjacent ducts. This protects the cables in adjacent ducts better from injury in case of burn-outs. The single duct also has the further advantage that the joints may be staggered, thus making it much more difficult for the heat of the arc to pass to the adjoining ducts.

In laying a line of ducts the grades must be carefully established, so that the duct line will tend to drain toward the manholes. If pockets are formed,



STANDARD SINGLE TILE DUCTS

Fig. 7

the standing water is likely to freeze in winter weather and injure the insulation of the cables, as well as breaking the tile.

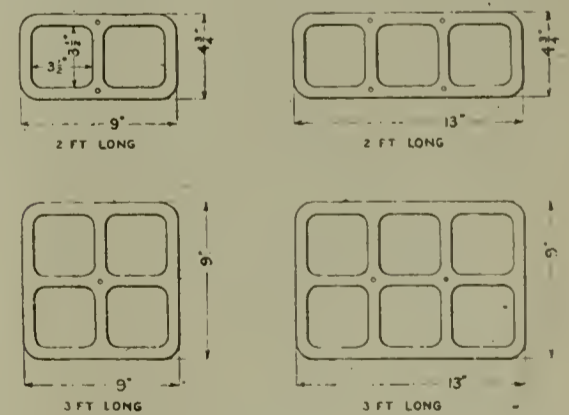

STANDARD MULTIPLE TILE DUCTS

Fig. 8

It is important that manholes where work must be done frequently or where transformers or junction boxes are installed be connected through a tap to the sewer. The accumulation of water in such a manhole may start trouble or may seriously delay repair-work which is urgent.

The conduit line must be protected when laid in public thorough-

fares from future excavators. It should also be made secure against the possibility of getting out of alignment, and thus injuring the cable or making it impossible to pull cable in or out. In view of these considerations, it is usual to surround important lines with concrete on all sides to a thickness of 3 in. This makes an envelope thick enough to support short sections around which excavations may be made later and also protects the tile from the laborer's pick. In some cases it is considered advisable to lay 2-in. plank on the top of the conduit as a warning to those digging. The concrete, when set, acts as a water-shed to a large extent and minimizes the entrance of leaking gas into the conduit system.

The design of manholes is dependent largely upon the particular use to which they are to be put and their construction must often be modified to suit conditions which vary widely. The walls of manholes are made of brick or concrete.

Where excavations can be made without interference with other piping or duct systems, manholes may be economically constructed according to a standard design, for which forms may be constructed. When any obstruction is encountered the form is not practical and walls must be built up of brick. In most cases the floor may be made of concrete without difficulty, as no forms are needed.

The brick should be of the quality known as sewer brick, and should be laid up with a good cement mortar, an 8-in. wall being ample for the requirements in most cases. The roof must have sufficient strength to support the heaviest street traffic, and its design therefore varies with the size and shape of the manhole. In general the necessary strength is secured by the use of steel beams as a framework. Worn rails are sometimes a cheap form in which to purchase steel for such purposes. The framework is filled in with brick, concrete or terra cotta building arches. The rail construction with concrete is illustrated in Fig. 4. Manhole covers and frames are made of cast iron of rugged design, the top surface of the cover being a broken one to prevent accidents to teams or pedestrians. In metropolitan work it is found very desirable to provide openings in the covers for purposes of ventilation. The amount of heat liberated in a heavy line of low-tension cables is very appreciable in some cases and ventilation must be provided to keep the temperature as low as possible. The ventilated manhole is also much less likely to accumulate gas in sufficient quantity to cause an explosion or to interfere with work. Serious

explosions have occurred in manholes which were not ventilated.

The cost of underground work has been discussed by several writers, notably W. P. Hancock, who presented a paper which appears in the 1904 Proceedings of the National Electric Light Association, and Louis A. Ferguson, whose paper was read before the International Electrical Congress at St. Louis in 1904 and appears in the proceedings of that body.

The figures given by Mr. Hancock represent experience in the City of Boston primarily, while those of Mr. Ferguson were taken from work done in the City of Chicago.

The figures agree quite closely in the final results as to total cost, though arrived at differently, and they may therefore be taken as applicable to those portions of any city where the higher grade of construction is justified. Less expensive work can be and is sometimes done in the outlying portions of a city by omitting parts or all the concrete and depending upon plank for protection. The use of such construction must be a matter of judgment, the local conditions and importance of the service being the governing considerations.

The figures in Table 8 are those of Hancock showing the cost of conduit without manholes or paving for a 15-duct line laid up with single tile. Table 9 shows the elements of cost for a 5 by 5 by 7 ft. deep manhole, according to Hancock. The walls are of brick and the floor and roof of concrete. Table 10 shows the cost of duct lines of various sizes laid up from single tile without manholes, as given by Ferguson.

The costs of repaving are approximately as follows: Cedar block, 60 cents; macadam, 50 cents; granite blocks, \$1.00; asphalt, \$3.25 per sq. yd. These costs are higher if it is necessary to open up paving within the period in which the contractor's reserve is still effective, as the opening can be made only with his permission and subject to the terms dictated by him for repaving.

Table 11 gives the cost of the more common sizes of manholes, as reported by Ferguson. These figures include sewer connections, concrete roof and floor, with brick walls, but not repaving. The dimensions are given with depth from floor to roof inside the manhole as the last figure in each case.

The number of duct feet and manholes of each size having been laid out on a plan, the cost of the conduit line may be estimated from these tables with fair accuracy, the kind of paving and other local conditions being known.

For instance, with a macadam-

paved street, what will be the cost of a four-duct line 1000 ft. long with two 5 by 5 by 6 ft. and two 3 by 3 by 4-ft. manholes? From Table 10 the cost of four-duct line with paving at 50 cents is 0.25 per duct foot. There being 4000 duct feet, the conduit proper will cost \$1,000. From Table 11 the cost of the two 5 by 5 by 6-ft. manholes will be \$123.24 each, or \$246.48, while the two 3 by 3 by 4-ft. manholes will cost \$46.50 each, or \$93.00. The 5 by 5 by 6 ft. manholes require 10.67 sq. yds. of repaving each, or 21.34 yds., and the two small manholes require 8 yds. The cost of repaving 29.34 sq. yds. at \$.50 will therefore be \$14.67. The entire cost of the work will therefore be:

Conduit and paving.....	\$1,000.00
2 large manholes.....	246.48
2 small manholes.....	93.00
Repaving manholes.....	14.67
Total.....	\$1,354.15

The total cost, including manholes and repaving, is therefore equivalent to \$.33 per duct foot. If the paving had been asphalt at \$3.25 per yd., the conduit proper would have cost \$.40 per duct foot, or \$1,600.00, and the manhole repaving would have been \$95.35, making the total cost \$2,034.83. It is therefore important in selecting routes for through lines to choose those thoroughfares in which the cost of repaving will be a minimum.

TABLE 8  
Cost of 15-duct line.

	Per duct ft.
Lumber at \$15.00 per M.....	\$.0105
Concrete at 4.85 per yd.....	.0231
Mortar at 3.98 per yd.....	.0026
Tile at .05 per ft.....	.0502
Total material.....	\$.0864
Excavation and filling at 15 cts. per hr.....	.0266
Placing lumber at 20 cts. per hr..	.0004
Placing concrete at 15 cts per hr..	.0029
Placing mortar at 25 cts. per hr..	.0016
Laying tile at 50 cts. per hr.....	.0040
Hauling away dirt at 50 cts. per hr.....	.0047
Total labor.....	.0402
Inspection 50 cts. per hr.....	.0033
Engineering expenses.....	.0214
Incidentals 5 per cent.....	.0116
Per duct ft.....	\$.1629

TABLE 9.  
Cost of 5x5x7 manhole.

23.7 cu. ft. concrete at .202.....	\$4.78
2500 bricks at \$9.00.....	22.50
1013 lbs. R.R. iron at .0125.....	12.67
Manhole frame 962 lbs. at .015..	14.43
1½ yds. mortar at \$3.98.....	4.47
Sewer trap.....	5.65
30' sewer pipe at .30.....	9.00
Total material.....	\$73.50
Excavation and filling 785 yds. at .0278.....	\$21.82
Repaving at \$1.44 per sq. yd.....	11.95
Removing dirt.....	4.30
Laying brick.....	7.00
Total labor.....	49.07
Grand total.....	\$122.57

TABLE 11  
COST OF MANHOLES, EXCLUSIVE OF COST OF REPAVEMENT.

MATERIAL.	*3'x3'x4'		4'x5'x5'		5'x5'x6'		6'x6'x6'		7'x7'x6'		*8'x8'x6'	
	Quan.	Amt.	Quan.	Amt.	Quan.	Amt.	Quan.	Amt.	Quan.	Amt.	Quan.	Amt.
Excavation and removal of dirt, at 87½ cts. per cubic yard.....	\$3.70	\$3.24	\$7.77	\$6.80	\$16.30	\$14.26	\$19.00	\$16.63	\$24.00	\$21.00	\$29.63	\$25.93
Brickwork—Sides at \$9.50 per cubic yard.....	1.67	15.86	2.92	27.74	4.17	39.62	4.50	42.75	5.17	49.12	5.83	55.39
Concrete—Bottom at \$7 per cubic yard.....			0.37	2.49	.56	3.92	.67	4.69	.91	6.37	1.18	8.26
Concrete—Top at \$8 per cubic yard.....	.56	7.00	.96	7.68	1.35	10.80	1.55	12.40	2.01	16.08	2.50	20.00
Iron in roof at 3 cts. per lb.....	105 lb	3.15	129 lb	3.87	153 lb	4.59	178 lb	5.34	215 lb	6.45	227 lb	6.81
Sewer connection and permit at \$25 each.....			1	25.00	1	25.00	1	25.00	1	25.00	1	25.00
Trap and backwater valve at \$6.50 each.....			1	6.50	1	6.50	1	6.50	1	6.50	1	6.50
Sewer grates at 30 cts. each.....				.30		.30		.30		.30		.30
Frame and cover at \$15 each.....	1	15.00	1	15.00	1	15.00	1	15.00	1	15.00	1	15.00
Supervision and incidentals.....		2.25		2.25		2.25		3.25		3.25		3.25
<b>Totals.....</b>		<b>\$46.50</b>		<b>\$97.63</b>		<b>\$123.24</b>		<b>\$132.06</b>		<b>\$149.07</b>		<b>\$166.44</b>
Square yards repaving required.....	4.00		8.89		10.67		12.00		13.89		16.00	

\*Last dimension is depth. Depth of manhole given in the clear inside dimension.

These prices are based on 3 in. of concrete on all sides of conduit. Portland cement at \$1.50. Tile to be laid by brick mason at 60 cents per hour. Top of concrete to be 30 in. below surface of street. Tile at 5 cents per duct foot.

TABLE 10.

Approximate Cost of Single Duct Conduit (in cents per Duct Foot.

No. of Ducts	COST OF REPAVING, PER SQUARE YARD						
	\$0.50	\$1.00	\$1.50	\$2.00	\$3.00	\$3.50	
2.....	24	29	34	38	43	52	56
4.....	22	25	27	30	33	38	41
6.....	20	22	24	26	28	32	34
9.....	19	21	22	24	25	28	30
12.....	19	20	21	23	24	26	28
16.....	18	19	20	21	22	24	25
20.....	17	18	19	20	21	22	23
24.....	17	18	18	19	20	21	22
30.....	16	17	17	18	19	20	21
40.....	16	17	17	18	18	19	20
50.....	16	16	17	17	18	19	19

**Comparative Cost of Various Street Illuminants\***

In the following tabulation an effort has been made to present in condensed form actual figures comparing various systems of street lighting:

Lamp	Tungsten Incan.	Gem Incan.	Carbon Incan.	Nernst Horiz.	Welsbach Single	Mag. Arc
Rated mean horizontal candle-power.....	40	40	40	..	60	60
Candle-power—10 degrees below horizontal (service conditions).....	46	46	46	35	36	36
Watts consumption.....	50	50	108	115	..	..
Gas consumption—cubic feet per hour.....					3	3
Life-hours.....	1,000	1,500	1,000	1,000	600	300
Number of lamps per mile to give minimum illumination of 0.024 foot-candle.....	60	60	60	69	68.5	68.5
Watts per candle-power—10 degrees below horizontal....	1.09	1.09	2.35	3.04	3.28	..
Renewal costs, each.....	\$1.35	\$1.35	\$0.585	\$0.585	\$0.40	\$0.35
Renewal cost per year of 4,000 hours.....	5.40	3.60	2.34	2.34	2.67	4.67
Rate						
Energy costs per light } 1c. 2.00 2.00 4.32 5.60 4.60 .. .. 12.16						
year of 4000 hours } 2c. 4.00 4.00 8.64 11.20 9.20 .. .. 24.32						
at different rates per } 5c. 10.00 10.00 21.60 28.00 23.00 .. .. 60.80						
kilowatt-hour. .... } 10c. 20.00 20.00 43.20 56.00 46.00 .. .. 121.60						
Gas at 40 cents per 1000 feet..	..	..	..	..	4.80	4.80
Gas at \$1.00 per 1000 feet.....	..	..	..	..	12.00	12.00
Lighting and extinguishing per lamp per year at 2 cents per day.....					7.30	7.30
Total cost of energy and renewal per lamp per year of 4000 hours at above rates of energy.....	7.40	5.60	6.66	7.94	7.27	..
Gas at 40 cents per 1000 feet... } 9.40 7.60 10.99 13.54 11.87 .. .. 18.91						
Gas at \$1.00 per 1000 feet.... } 15.40 13.60 23.94 30.34 25.67 .. .. 31.07						
Total cost per mile—1-cent energy, 40-cent gas.....	\$444.00	\$336.00	\$399.60	\$476.40	\$501.63	\$1148.75
						\$1020.65
						\$315.80

\* National Electric Light Association—P. D. Wagoner.

It will be noticed from the preceding tabulation that the life of the welsbach mantle has been taken at 300 hours and also at 500 hours. It is the impression of the writer that the latter figure is more nearly correct. However, there are certain authorities that give the average life of the welsbach mantle at 300 hours.

In the above comparisons the costs of poles and wires in the electric systems and posts and piping in the gas system have been disregarded, on account of the widely varying values, which are necessarily dependent upon local conditions; however, gas piping would ordinarily be more expensive than wiring for the electric system.

For the same reasons, interest and depreciation have been disregarded, also labor of renewals except in the case of magnetite arcs, where renewal charges include the following:

- Trimming,
- Electrodes,
- Globes,
- Tube renewals,
- Repair.

In each of the installations the spacing of the units has been made such that the minimum illumination

will be 0.006 foot-candle, even should alternate lamps be extinguished; with all lamps burning the minimum illumination—that is, the intensity midway between the lamps—would be about 0.024 foot-candle, which is ample.

Above is given the comparative cost of operation per year of Gem and tungsten lamps in a specific installation:

In addition to the saving in the cost of operation, the capacity of the system is increased 116 per cent. by the tungsten lamp; that is, the number of lamps installed can be increased 116 per cent. without any increase in generating or regulating apparatus of the system.

**Water Power Development at Great Falls, Mont.**

Plans are being perfected for the immediate development of two powers near Great Falls, Mont.

The upper development is to be made at the falls known as Coulter's, Crooked and Rainbow, situated about three miles down the river from Great Falls. At this point the head will be about 105 ft. high. A crib dam about 25 ft. high will be built with masonry head gate, and waste gate structures. A steel penstock, 22 ft. in diameter and about 2500 ft. long, will extend from the intake to the power-house. The latter will be of masonry construction, containing about 30,000 h.p. of wheels and electrical apparatus.

The lower development is about 12 miles below Great Falls. Here the fall is about the same as at the upper development. The dam will be of the same construction as at Rainbow Falls, the canal being 500 ft. long, and directly below this the power-house. The equipment will be a duplication of that at the upper development.

The engineering corps already organized is now busily engaged in making surveys and in the preparation of plans. The work on the coffer dam is already begun and it is expected to push the work of development to completion as fast as possible.

# The Probable Effect of the Higher Efficiency Incandescent Lamps on Central Station Income

By E. F. TWEEDY\*

THE year which has elapsed since the last meeting of this Association has witnessed the commercial introduction of the multiple tungsten lamp of American manufacture, and it seems almost incredible—in view of the tungsten lamp situation which confronts us to-day—that only twelve short months have intervened since the president of this Association presented the following question for consideration: "Is there any actual commercial use at the present time of tungsten lamps, except a very small experiment we know of at Sault Ste. Marie?" This question was restricted to lamps in commercial use, as distinct from street lighting. In the replies which were made to this inquiry, mention was made of a series circuit or two of street burning lamps in commercial use in a certain town, and the installation referred to in the question—which consisted of 30 volt lamps in series on 120 volt circuits, and used for store lighting—was described; also one single large installation of multiple tungsten lamps was cited, but these lamps were of foreign make. This was the condition of affairs only one year ago.

Many comforting assurances have been forthcoming from time to time that it would be a physical impossibility to produce tungsten lamps in sufficient quantity to effect other than a gradual adjustment of central station policy with respect to them. Only a few months ago it was stated by one eminently qualified to express an opinion upon the subject that the combined output for the year 1908, of all the lamp works in this country, could not possibly exceed one million tungsten lamps, which would amount to only about five per cent. of the increase in output of incandescent lamps in 1907 over that of the preceding year. To show how rapidly conditions have changed since the foregoing statement was made, it is only necessary to mention that one company alone now claims to be in a position to turn out some 35,000 tungsten lamps a day, which means a possible output, for this one company, during the few remaining months of this year, of over 3,000,000 lamps.

While the introduction of the tung-

sten lamp has been exceedingly rapid, when viewed from the central station standpoint, it is nevertheless being greatly retarded by the present high price at which the lamp is being sold, by the present fragility of the lamp filament, and by the fact that the lamp is being made in sizes of comparatively high candle-power only. There is no likelihood that these conditions will long continue. While the cost of developing the tungsten lamp has doubtless been considerable, it does not appear that the material of which the filament is composed, or the process which is employed in its manufacture, is particularly costly. The form of construction which is required in order to provide a proper support for the filament naturally increases to some extent the cost of manufacture, but this added cost is certainly not of sufficient amount to justify anything like the present market price of the lamp. The capacity for production in this country has, to all appearances, about overtaken the present demand under the conditions now existing, while lamps of foreign make are also being placed upon the American market in competition with our own product. Under the above conditions, it would appear that the present high price of the tungsten lamp must necessarily be of short duration, and that eventually a very considerable reduction in price may be looked for.

The various physical and electrical properties of the tungsten lamp have been so thoroughly treated in numerous articles during the past year, that it is unnecessary to touch upon them at this time. The average life of these lamps affords little cause for complaint at the present time. The fragility of the filament is gradually being overcome, and it should offer no permanent obstacle in the way of the general adoption of the lamp for commercial use. The demand for a lamp of lower candle-power—particularly in the field of domestic lighting—is being felt, and this want will soon be filled; in fact a 20-candle-power, 110 volt lamp of foreign make has recently appeared upon the market, and the appearance of an American lamp of corresponding candle-power may soon be expected. With the above limitations removed, the field of

usefulness for this lamp will be greatly extended, and this will be accompanied by an extremely rapid increase in its production and use. It may take a few years to bring about the results which are presaged in what follows, but, on the other hand, a much shorter period may witness their accomplishment, judging from the rapid development which has taken place during the past year. It is possible that some other incandescent lamp may appear in the meantime—one possessing qualities far superior to the tungsten—but the effects of such a lamp would not be materially different, except as regards degree, from those which we may expect from the tungsten lamp.

In considering the probable effects of the higher efficiency lamps upon central station income, the matter resolves itself quite distinctly into two separate questions: First, what effect will these lamps have upon the income now being derived from those lighting installations which are being supplied with central station service?

Second, will these lamps enable central stations to secure those classes of lighting installations which have heretofore been unobtainable, and, if so, what effect will the securing of these classes of installations have upon income as a whole?

The present users of central station service for lighting may be divided into three classes, according to the probable basis upon which each will adopt the higher efficiency incandescent lamp. The first class will comprise those customers who are only using electric light in sufficient quantity to provide a reading or working illumination adequate for their needs, and who have no object in securing a greater amount of illumination than will fulfill this fundamental condition. Those who are employing electricity in lighting the home, the office or the factory, may be mentioned as coming within this class. The tendency among such customers—provided the present illumination is sufficient in amount—will be to substitute the tungsten lamp for the carbon lamp upon a basis of approximately equal candle-power, thereby securing practically the full benefit of the saving in cost of current resulting from the use of the higher efficiency lamp. It

\*Association of Edison Illuminating Companies.

is, however, hardly reasonable to expect a reduction in income from this class of customers in any way proportional to the increase in lamp efficiency. It is very probable that the lessened cost of electric light will result in a much less rigid regard for economy in its use; also that there will be a tendency among this class to extend the use of electric light by installing tungsten lamps where gas burners are now being used. Moreover, in many residences where questions of economy are subordinate to aesthetic considerations, the use of the carbon filament lamp, particularly of the smaller candle-power sizes and of other than standard types will in all probability continue indefinitely. Taking all of the above influences into consideration, we may perhaps safely assume that the present income from this class of customers will have suffered a reduction of, say between 30 and 40 per cent. by the time the higher efficiency lamps have come into quite general use.

The second class of customers consists of those who are using electric light in sufficient quantity to secure a fairly satisfactory amount of useful illumination, but who could profitably employ a much greater amount of light. This class has limited its amount of illumination heretofore, principally on account of the cost. It now affords a fruitful field for active work upon the part of central stations; not for the purpose of securing additional income, but in order to retain present income. When one considers the great number of comparatively small stores where electric light is being used to-day in only a very small way, it is evident that a very considerable amount of present income may at least be conserved by convincing this class of the benefits to be derived from more brilliantly lighted show windows and from a greatly increased amount of interior illumination, now that both of these advantages may be secured without any added cost. Unless this is done, the income from this class is liable to be somewhat reduced, at least for a time. We will assume, however, that central stations in general avail themselves of this opportunity and that the income from this class will undergo a reduction of only some 10 per cent.

The third class of customers comprises those who are now using electric light at what might be termed the "saturation point" for the present standard of illumination. From this class central stations may well expect a considerable loss in revenue. The customers found in this class are those who early recognized the business drawing properties possessed by a place which is brilliantly illuminated

and also the possibilities of effective advertising which lay in the extensive use of electric light. This employment of electric light in much greater quantity than is actually needed to provide a satisfactory amount of useful illumination, is most frequently observed in our larger cities, and is principally limited to certain kinds of stores, saloons, cafes and certain places of amusement. As an example of this class, the United Cigar Stores Company, whose stores are so widely scattered, may be cited. During the year 1907 this company spent approximately \$80,000 for electric light upon Manhattan Island alone. By means of the tungsten lamp, this company expects to reduce this yearly expense by practically one-half, and this result is to be accomplished without lowering the high standard of lighting which has characterized the stores of this company from its inception. There may be a tendency for this class to further increase the amount of its illumination, as the general standard is raised, in order to preserve that distinction which a superior illumination affords, but the immediate purpose will be to retain the present amount of light, and thereby effect a saving in current consumption almost directly proportional to the increase in lamp efficiency. It is perhaps safe to assume that the reduction in present income from this class will be in the neighborhood of 50 per cent.

There is another comparatively small class of existing installations in which low candle-power lamps are generally used, and where the efficiency of the lamps, as light sources, is of little consequence, as a small amount of light is required for each lamp. Such installations as signs, outline and decorative lighting, etc., afford examples of this class, and it is probable that the carbon filament lamp will here continue in use for some time to come.

We may now venture a prediction as to the probable effect of the higher efficiency lamps upon central station income as a whole. We will assume that the average income from commercial lighting is 60 per cent. of the total income. (The percentage for the State of Massachusetts for the year ending June 30, 1907, was 60.7). There is no available data however, whereby we may apportion the income from commercial lighting among the three classes of customers which have been assumed. It is evident that those customers, of which class one is composed—those who have no object in using light in greater quantity than will suffice for a satisfactory minimum of useful illumination—are by far the greatest numerically, and it can perhaps be assumed, without much error,

that 50 per cent. of the present income from lighting is secured from this class. Those customers who have been placed in class two are much greater in number than those of whom class three is composed, but it is probable that the income derived from the one class is not far different from that secured from the other. With the foregoing assumptions, together with those which have been made with respect to the percentage loss in income from each class of customers, we have the following summary showing the probable resultant percentage loss in total income:

	Loss in Income Per Cent.	Relation to Total Income Per Cent.	Loss in Total Income Per Cent.
Class I.....	35	30	10.5
Class II.....	10	15	1.5
Class III.....	50	15	7.5
			19.5

Such a percentage of loss in present income as the above figures disclose, would prove a serious matter to the majority of central stations. Unless this threatened loss can be offset by revenue from some new and undeveloped source, the central station industry will undoubtedly experience a decided setback. This leads directly to a consideration of the second question: Will the higher efficiency lamps enable central stations to secure those classes of lighting installations which have heretofore been unobtainable, and, if so, what effect will the securing of these classes of installations have upon income as a whole?

The classes of lighting installations which central stations have heretofore been largely unable to secure, are those in which gas or some other illuminant is used which is considerably cheaper than the electric light when produced by the carbon filament lamp, and also those installations where a private plant is being used to supply electric current as a purely operating cost per unit of output which is less than the corresponding price per unit of the central station supply. The possibility of securing the second class of installations through the aid of a higher efficiency lamp will first be considered.

Where the central station rate is now very slightly in excess of the plant costs per kilowatt hour, the introduction of a lamp of higher efficiency will probably result in turning this cost difference in favor of the central station service, particularly where lighting forms a large part of the total load. Fixed charges and labor will not be reduced proportionately to output, so that the plant cost per unit produced should be slightly increased. Where power forms the bulk of the load, however, little or no change may be looked for in the relative costs of private plant and central station supply. To offset this advan-

tage which may possibly accrue to the central station with respect to certain installations of the private plant class, there will be other installations of this class, which are now securing central station service at a lower unit cost than could be obtained with a private plant, by reason of a low rate due to a large consumption, and which may now possibly be raised to a slightly higher rate on account of the reduced consumption which will result from the use of a lamp of improved efficiency.

A great number of private plants, which are more or less overloaded with their present lighting equipment, will be given a new lease of life through the aid of a more efficient lamp. Many such plants have been abandoned in the past in favor of central station supply due to this very condition, particularly in those places where the central station has refused service upon a breakdown or overload basis. With the increase in capacity which private plants in the above condition will now experience, it is probable that a much fewer number will, in the immediate future, adopt central station service from this cause. As private plant costs are greatly dependent on output, it is necessary to produce a large number of kilowatt hours in order to secure a reasonably low unit cost, and central stations should now be even better able than in the past to take advantage of this condition which is so necessary to the economical operation of a private plant. If a 1000 light plant has been the smallest in size which could be profitably operated heretofore in competition with the central station service, this limit should now reside in a plant having a capacity of 2000 lights, assuming that power forms a small proportion of the total load. On the whole, it could appear that the higher efficiency lamp will be of considerable benefit to central stations in dealing with the private plant class of installations, and that the income from this class should eventually be considerably augmented, due to a large increase in the number of such installations supplied. The heating question will probably still continue to be a very important consideration among certain installations of this class; but as the amount of exhaust steam is insufficient at present in many such installations to effect the entire heating without the addition of a certain amount of live steam, a considerable reduction in the amount of available exhaust, as a result of a largely reduced lighting load, should tend, in many instances, to lessen materially the importance of this heating question in its bearing upon the economy of the private plant.

While we are inclined to believe at times that the electric light is the world's illuminant of to-day, such a belief is far from the actual truth. "The Great White Way" impresses us with the marvelous development which has already taken place in the field of electric lighting, but we are apt to overlook the millions of homes where the gas jet still reigns supreme; as well as the countless stores which the gas "arc" or Welsbach burner still lights—and heats; and also the fact that kerosene and even candles are still being sold in increasing quantities. Electricity has only commenced its conquest of the lighting field, and in this very fact our hopes for the future must reside.

In order to bring out more clearly the relative position which electricity occupies with respect to gas in the lighting field to-day, and to show the possibilities which lie before the former in this field, the conditions which exist in the State of Massachusetts, as shown by the report of the Board of Gas and Electric Light Commissioners for the year ending June 30, 1907, will be cited. This State has been selected because of the completeness of its statistics covering the manufacture and sale of gas and electricity within its borders. While the report above referred to is complete in most particulars, it contains no direct information upon several points which appear in what follows, and it has, therefore, been necessary to make certain assumptions, but these have been based upon data secured from other and what are thought to be equally reliable sources.

The amount of coal gas sold by meter to consumers in the State of Massachusetts during the year mentioned was, in round numbers, nine billion cubic feet. If we estimate the amount of gas sold for heating, cooking and power purposes at one-third of this total, it leaves a remainder of approximately six billion cubic feet which was used for lighting, exclusive of that used in street lamps. In order to obtain some idea of the quantity of light resulting from this consumption of gas, it will be necessary to make certain other assumptions, as follows: First, as regards the quantity of gas consumed in mantle burners, as compared with the quantity consumed in open burners; second, as to the average duty of the two types of burners, as expressed in candle-power hours per cubic foot of gas consumed. Bearing upon the first point, the following passage occurs in the recent decision of the Railroad Commission of Wisconsin, which establishes a calorific rather than a candle-power basis for the measurement of the value of illuminating gas:

"Under conditions governing the use of gas in Wisconsin, it appears that by far the largest amount is used for purposes such that the heating value is a measure of serviceable value of the gas. There is a small percentage of gas consumption, believed to be materially under 10 per cent., which is used in open flame burners, and in which the candle-power is a measure of its value." At a recent inquiry into an order to reduce the candle-power of the gas of Edinburgh (Scotland) from 20 to 14, held by the Edinburgh Gas Commission, an estimate of the gas used in that city in open flame burners was given as 15 per cent. of the total gas used. The use of mantle burners in Edinburgh has been somewhat retarded on account of the high candle-power of the gas.

It is apparently safe to assume, in the present instance, that 80 per cent. of the gas used in private lighting is consumed in mantle burners. If we assume an average of  $2\frac{1}{2}$  mean spherical candle-power hours per cubic foot of gas for the open flame burners, and an average of 12 for the mantle burners, the total mean spherical candle-power hours produced would be, roughly,  $60\frac{1}{2}$  billion. In order to produce an equal amount of light by means of tungsten lamps, with an average duty of 1.6 watts per mean spherical candle-power, an expenditure of approximately 97 million kilowatt hours of electrical energy would be required. According to the report of the Gas and Electric Light Commission about 115 million kilowatt hours of electrical energy were sold to commercial customers during the year ending June 30, 1907, at an average rate of a little over  $6\frac{1}{2}$  cents per kilowatt hour. While the report shows the distribution of income among the various classes of service, no figures are given to show the kilowatt hours sold for commercial lighting as distinct from power and heating, and the percentages which are shown in the following table for the kilowatt hours sold for various purposes, have been assumed from similar statistics obtained from other localities:

SUMMARY SHOWING PERCENTAGE DISTRIBUTION OF INCOME AND OF KILOWATT HOURS SOLD FOR THE COMPANIES OF MASSACHUSETTS FOR THE YEAR ENDING JUNE 30, 1907.

	Income Per Cent.	Kilowatt Hours Sold Per Cent.
Commercial Lighting.....	60.7	52.5
Public Lighting.....	19.9	22.5
Power.....	16.5	25.0
Other sources.....	2.9	.....
	100.0	100.0

With the assumptions which have been made, it is now possible to estimate the effect upon total income



which would result from the central stations of Massachusetts securing various percentages of the total output of light now being obtained from gas. This is shown graphically in cut, and it will be observed that, in order to offset the probable loss in income from present customers, 23.8 per cent. of the present commercial gas lighting must be secured by the central stations. There is every reason to believe that the above result can be accomplished with little effort on the part of the central stations; but in order to make considerably greater inroads upon gas than the preservation of present income alone requires, special and well-directed efforts will doubtless be found to be necessary.

In endeavoring to secure, as customers, that class which is now using gas for lighting, central stations have heretofore been obliged to face two serious obstacles, namely, the greater cost of electric light for a given amount of illumination and the high cost of electric wiring. The first obstacle has now been largely removed. While our gas friends are endeavoring to show that the mantle burner has undergone an improvement which is almost, if not quite, equal to that of the electric incandescent lamp, and that the best inverted mantle burners are now able to give about three times as much light for the same money as the tungsten lamp—based on dollar gas and electricity at 10 cents per kw-hr.—the true ratio of costs is something quite different. When the average candle-power throughout life is taken as a basis for comparison, and when the tungsten lamp is equipped with its proper reflecting and diffusing shade, as it always should be, the useful amount of light—as measured by the mean lower hemispherical candle-power—for a given cost, including the necessary renewal charges, is perhaps  $1\frac{1}{2}$  to 1 in favor of the ordinary type of inverted mantle burner. The ordinary gas "arc" is of considerably lower efficiency, and it is practically on a par, as regards operating cost, with the tungsten lamp when the latter is properly installed. The cost difference in favor of the best gas burners is now so slight that it should have little weight against the many advantages which are possessed by the tungsten lamp and are not shared by any possible form of gas lamp.

A number of central stations have already taken advantage of the advent of the tungsten lamp to commence an active campaign against gas, and the so-called gas "arc" has, in the majority of cases, been selected as the most vulnerable point of attack. A brief account of the policy which is now being pursued by The New York Edison Company, in order to

secure this class of business, is given, in the hope that it will elicit what some of the other member companies are doing in this direction, and thus lead to a discussion of this important subject.

About three months ago The New York Edison Company commenced a canvass of those stores where gas "arcs" were found to be in use, with the avowed purpose of replacing such lamps with tungsten fixtures. Under the plan as now in effect, the Company agrees to have the wiring installed by a local contractor under the customer's direction. The customer selects the fixtures either by visiting the Company's display room, where a complete line of fixtures is on exhibition, or from a cut in the handbook with which each solicitor is equipped. The fixtures which are carried in stock cover a considerable range in price, which varies according to the finish and the number of lights. The Company installs the fixtures complete,

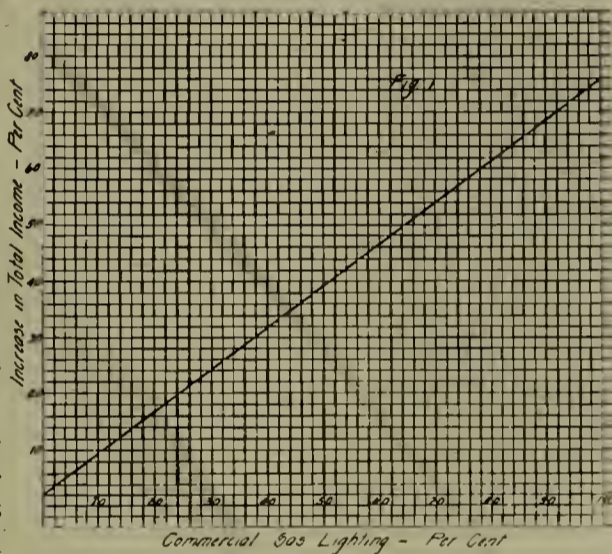

with shades and lamps. The customer agrees to pay the Company a certain price which will cover the cost of the wiring, the fixtures, the shades and the lamps, this payment to be made in twelve equal monthly instalments. If the premises should be vacated before the final payment has been made, or if the service should be discontinued, for any reason, before the last instalment has been made, the amount necessary for a complete liquidation is payable at once. Under this plan the Company assumes no responsibility for the tungsten lamps after they have been delivered in good condition. It is, however, questionable whether this is the best policy to pursue with respect to these lamps, at least while they are as costly and as subject to breakage as they are at the present time.

Among the class which central stations are now endeavoring to secure as customers by means of this lamp, it would be a serious matter if a lamp costing a dollar to a dollar and a half, becomes useless after only a few hours of service. A few experiences of this

nature would tend quite effectively to discredit the tungsten lamp with the customer and it would be difficult to overcome this prejudice later, when the lamp will have become lower in price and more durable in operation. If the lamp be supplied to this class upon a rental basis the above difficulty would be avoided. While the payment of a small monthly charge for lamp maintenance would probably be looked upon as a trivial expense by this class, the question of spending something over a dollar for a lamp of uncertain life, will be viewed in quite a different light. If we take the case of a customer having a four-light fixture, and one lamp becomes useless, the probabilities are that the customer will defer the purchase of a new lamp for some little time, during which period the revenue of the central station will be reduced by 25 per cent.; if, however, the customer is being supplied with lamps by the central station upon a rental basis, the occurrence of such a loss in revenue is much less probable.

There is another point in connection with the replacing of gas "arcs" by tungsten fixtures, which deserves careful consideration, and that is the use of effective reflecting shades with the tungsten lamps. It is unlikely that our friends who are in the gas business will stand complacently by and watch the tungsten lamp drive gas from the lighting field, particularly now that the inverted mantle burner is here with its improved efficiency. It is stated that a gas fixture, having inverted mantle burners equipped with prismatic reflectors, is soon to make its appearance. The undeniably high efficiency which such a unit will possess, makes it necessary at this time for central stations to see that the tungsten lamp is installed in the most efficient manner possible, and that the required redistribution of the light is secured with the smallest possible loss.

It would appear that the tungsten fixture affords a means whereby central stations may quite readily secure that large class of small stores, wherein the gas "arc" and the individual mantle burner, have, until now, been so strongly entrenched. In order to secure this class, however, it will probably be necessary, in the majority of instances, for the central station to assume the initial outlay for the wiring, but, where this is done, it should not prove difficult to secure an eventual reimbursement for this outlay from the customer, by adopting some method whereby such payment will not be at all burdensome.

For a time, after the carbon incandescent lamp had reached a certain stage of development, and before the Welsbach mantle had come to the

assistance of gas lighting, electric light was frequently styled—more particularly abroad—"the poor man's light." Whether or not such a term was deserved at that time, it is certain that at the present time the use of electric light is largely confined to the comparatively well-to-do. This is particularly true when it comes to the lighting of the home. While the use of gas in domestic lighting is by no means confined to the poorer classes, it is among the latter that its stronghold is to be found. The higher efficiency lamp now enables electricity to enter this stronghold and to compete with gas on a basis of comparative cost. In endeavoring to secure this class of domestic lighting, however, central stations will be confronted with a serious problem in the shape of the installation cost. While the cost of the light is now no barrier in the way of securing this class, the cost of the necessary wiring will doubtless prove to be, unless central stations can meet the situation in some such way as that mentioned above in connection with the introduction of tungsten fixtures in a certain class of stores. Without some such plan being devised, the growth in the use of electric light among this class is likely to be extremely slow.

A plan proposed by Mr. John MacKenzie, which appears in several recent issues of the *Electrical Review* (London), has as its object to provide an inexpensive system of wiring to be employed in the cheaper class of dwellings, such as the tenement houses of our larger cities and to be used in connection with the tungsten lamp. This plan applies only to alternating current systems, however, and it consists in supplying a number of installations in one building, or in several closely grouped buildings, from a single auto-transformer, having secondary circuits of only 25 volts. With this low voltage, it is claimed to be perfectly feasible to use flexible cord, mounted upon porcelain insulators attached to the side walls and ceilings. It is estimated that the cost of such an installation would be about on a parity with that of the gas piping, which would otherwise be required. While such a system would probably find little favor in this country, it is worth mentioning while calling attention to a problem which is likely to cause considerable difficulty in its solution. This question of a cheap and, at the same time, safe system of wiring now assumes an importance which it has not attained heretofore. In order that central stations may rapidly extend the use of electric light among the class of dwellings under consideration, a scheme of wiring should be available

that would be considerably cheaper than any of the methods now commonly employed. It is perhaps unnecessary to call attention to the fact that no form of concealed wiring could possibly fulfill the above requirement. The objection to exposed wiring which is usually encountered among the better class of homes, would hardly be met with among the cheaper class of dwellings, where the matter of appearance would have comparatively little weight.

The number of lights in each installation among the cheaper class of dwellings would be exceedingly small, and this would permit of a less expensive meter being used, for a high light load accuracy would be unnecessary. While the income from each individual installation of this class would be of small amount, the aggregate income would be very large. The report of the Massachusetts Commission, above referred to, will here be cited once more in order to show the difference between the present consumers of gas and the present users of electricity. While the total income from gas sold for commercial purposes is shown to be 15 per cent. greater than the income received from the sale of electricity to private consumers, the gas companies are credited with over four times as many customers as the central stations. While the former have an annual income per customer of \$24, the latter secure an average of \$88 from each customer.

The employment of the tungsten lamp for street lighting preceded somewhat its introduction for commercial use, and we are now able to judge in a measure what its effect is to be in this class of lighting. It is replacing the carbon and the metalized filament lamp in this service with extraordinary rapidity, and the reason for this is obvious. It is stated that one of the largest manufacturers of series incandescent lamps for street lighting purposes has already discontinued the manufacture of the carbon filament lamp, except on order. There is every reason to believe that the tungsten lamp will have this entire field to itself at a day not far distant. While in this class of lighting it is now possible, in the majority of instances, for the central station to secure the entire benefit from the introduction of this lamp, it is noticeable that certain central stations have voluntarily sacrificed a considerable portion of this possible benefit, in order that the municipality might profit by a lamp of considerably higher candle-power. It is more than probable that the total benefit resulting from the use of a more efficient lamp in street lighting service, will ultimately

be secured by the public, either in the form of a greatly increased amount of street illumination or by a reduction in the price charged per lamp per year, or by a combination of both. Until this condition obtains, however, central stations may well expect to secure an increase in the amount of income derived from each kilowatt of station capacity which is devoted to this class of service. The permanent benefit which central stations will secure from the higher efficiency lamp in street lighting service will probably be found in the complete elimination of the gas lamp, and in the large increase in the number of electric street lamps which is almost certain to accompany a reduction in the yearly price charged per lamp.

The foregoing survey of the lighting field has been based largely upon the conditions which exist in a single State, and the one which has been selected is exceptionally well "electrified" at the present time. The possibilities in the way of future central station growth which are seen to exist in that State, as the result of the advent of a higher efficiency lamp, are probably less than those which are now present in many other localities where there is a smaller consumption of electricity at the present time per capita of population. In summing up the situation as a whole, it would appear (1) that central stations are at the present moment confronted with the prospect of an immediate reduction in the income which is being secured from present lighting customers; (2) that such loss should, in the majority of instances, be rapidly regained by securing many of those lighting installations which have heretofore been unobtainable, and (3) that the majority of central stations are soon to experience a marked increase in total income, as the higher efficiency lamps bring about the more general use of electricity in that vast field which domestic lighting affords, and which has heretofore been the stronghold of gas.

#### Large Industrial Orders Continue to be Placed with a Leading Builder of Power Machinery

As continued evidence of awakening industrial activity in various parts of the country, mention of some of the orders taken by Allis-Chalmers Company, since the long list recently reported, is of exceptional interest at this time.

In the State of Wisconsin, where authorities estimate there are at least 2,000,000 h.p. in unused water-powers, large developments have recently been undertaken, and, among the important hydraulic turbine plants of this section

contracted for with Allis-Chalmers Company is that of the Northern Hydro-Electric Company on the Peshtigo River. The initial installation will consist of five horizontal twin-turbines, having each a capacity of 1500 h.p., or an aggregate of 7500 h.p., each direct-connected to a 1000-kw. alternating-current generator, with exciter units of 400-kw. combined capacity, all the machinery being of Allis-Chalmers Company's build. This plant, which is near that of the Wausau Street Railway Company, now being equipped with hydro-electric units by Allis-Chalmers Company, will be second in industrial importance for the Head-of-the-Lakes country only to the Great Northern Power Company's immense development, where 40,000 h.p. in Allis-Chalmers turbines—the largest single Francis wheels in the world—are in operation. The current generated on the Peshtigo River will be transmitted to Green Bay and neighboring towns, to be used for the operation of the street-railway system, commercial lighting and manufacturing purposes. Other large orders placed with Allis-Chalmers Company for hydro-electric plants include irrigation projects and central stations for power distribution in the middle West, the plans of which have not yet been made public. Four noteworthy machines now being shipped from Allis-Chalmers Company's works at West Allis are two 6500-kw. generators of the water-wheel type for the Niagara Falls Hydraulic Power & Manufacturing Company, Niagara Falls, N. Y., and two of 2500 kw. for the Cazadero Station of the Portland, Ore., Railway, Light & Power Company. These machines, which are designed for 25 and 33 cycles and speeds of 300 and 333 rev. per min., respectively, have recently shown some notable results on shop tests, the figures of which will be published shortly.

Among purchases of the steam turbines built by Allis-Chalmers Company are a 3250-kw. machine for the Pacific Mills, of Lawrence, Mass., which already have three of these turbines and generators in service; units of 1000-kw. capacity for the Cleveland, Southwestern & Columbus Railway and the City of Nashville, Tenn., and 500-kw. machines for the Webster & Southbridge Gas & Electric Company, City of Danville, Va., Pennsylvania Power Company, City of Dunkirk, N. Y., Willamette Valley Company, and City of Frankfort, Ind. In addition to the main units, these orders include exciters, power transformers, lighting transformers, condensers, circulating pumps, switchboards, etc., making complete power-plant equipments for the generation

and distribution of alternating current.

The Industrial Lumber Company, Beaumont, Tex., is preparing to install two engine-type generators of 450-kw. capacity, with 17 induction motors; the Johnson Chair Company, of Chicago, Ill., has bought a 500-kw. generator driven by a cross-compound engine; the City of Waverly, Ia., recently ordered a belted unit of 225 kw. and the Columbia Shade Cloth Company, New York, one of 300 kw., with a line of 26 direct-current motors; the City of Blue Ridge, Ga., has contracted for a 150-kw. alternator, with transformers, switchboard and motors; the Yampa Smelting Company for a 200-kw. induction motor-generator set and three 100-kw. transformers, the American Sugar Refining Company for a 500-kw. generator driven by a heavy duty engine, the American Oak Leather Company, of Cincinnati, for a 250-kw. belted unit, and the Heekin Can Company, of the same place, for additional equipment, including 21 motors. All of the machinery ordered is to be built in the shops of Allis-Chalmers Company and comprises auxiliary apparatus similar to that above mentioned.

The Oliver Iron Mining Company, which has over a score of Allis-Chalmers hoisting-engines installed in its mines at the head of Lake Superior, is having three additional units, 28 by 60 in., built in the West Allis shops at the present time; the Alaska-Treadwell Mining Company has ordered a sixth engine of the Allis-Chalmers Company's design; and the Right of Way (Can.) Mining Company, Octave Mining Company and Goldfield Consolidated Mining Company are pre-

Allis-Chalmers Company is the contractor for a vertical, triple-expansion self-contained pumping engine of 12,000,000 gallons daily capacity to be installed by the City of Milwaukee in its North Point Station not far from where the first machine of this type ever built has been in continuous service for more than twenty years. In industrial plants, the most noteworthy addition to present equipment is that of the Pittsburg Steel Company, which has ordered from Allis-Chalmers Company a double-acting vertical compound pumping engine for delivery of 15,000,000 gallons daily. The Hackensack Water Company, of New Milford, N. J., has contracted for a vertical triple-expansion pumping engine of 14,000,000 gallons daily capacity; the City of Rock Island, Ill., will install a centrifugal fire-service pump with capacity equal to a daily delivery of 2,000,000 gallons; the City of Coquet, Minn., a five-stage unit of 1,000,000 gallons daily; the Delaware, Lackawanna & Western Railway purchased a six-stage centrifugal pump for lifting 7,500,000 gallons daily; and the Metropolitan Water & Sewerage Board of Boston, Mass., has ordered a centrifugal pumping engine, with complete appurtenances, for a station of 100,000,000 gallons delivery daily.

#### The Electric Fault Finder.

A new and useful instrument called the electric fault finder has just been brought out by The Electric Controller & Mfg. Co., of Cleveland, Ohio, for detecting and locating grounds, short circuits, open circuits, leaks and other faults in armature coils, field coils, control circuits,

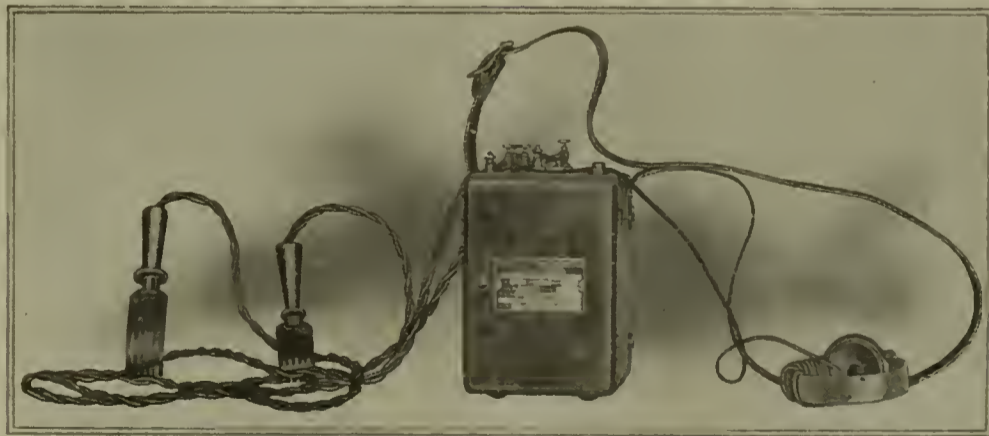

THE ELECTRIC FAULT FINDER.

paring to install similar units; except that the two hoists purchased by the first-named company will be driven by Allis-Chalmers motors instead of engines.

In the pumping-engine field a large number of negotiations are being brought to a definite conclusion—in some cases after months of delay. Among orders recently placed with

switchboard wiring, or other electrical circuits. The device not only indicates trouble, which is all that a magneto will do, but it finds or locates the trouble. For instance, in a motor armature, a faulty coil can be absolutely located and the nature of the trouble definitely ascertained. If a field-coil is damaged, the layer in which the fault lies can be absolutely determined. If

there is trouble in a bunch of control wires, in a multiple unit, train control, or other magnetic switch control, the faulty wire or pair of wires can be promptly located and the nature of the fault quickly found.

As will be seen from the accompanying view, the instrument consists of a small box provided with a strap so that it can be slung over the shoulder when testing motors in place as under a car or on overhead traveling cranes. From this small box leads go to a telephone receiver fitted with a head-piece so as to leave both hands free for testing. For working in very noisy places such as bridge and boiler shops, or some parts of steel mills, the head-piece may be fitted with two receivers, one for each ear, which will shut out all sound save that received from the instrument. This arrangement not only allows perfect testing to be done in noisy places, but enables partially deaf persons to use the instrument. In one case by adjusting the rheostat to give a very loud sound (more than the normal ear could stand) and using two receivers, a very deaf man did very accurate work with this instrument. From the box, leads of convenient length go also to two test terminals.

The Electric fault finder is cheap, small, portable, and requires no outside current to operate. It requires only one man to operate under any conditions, so there is no excuse for the tester desiring a helper.

The Electric Controller & Mfg. Co. have prepared a neat little booklet describing the Electric fault finder, and giving instructions in its use which will be sent to interested persons upon request.

#### The Keokuk Accident

The main power station of the Keokuk Electric Railway & Power Co., Keokuk, Ia., was lately wrecked because of a runaway engine. The fly-wheel, on a 500-h.p. Fleming engine, unable longer to withstand the speed, broke, tearing out the roof, one end of the building and completely wrecking the station. Fragments of the wheel wrecked a house several hundred feet away, the occupants narrowly escaping death. One engineer of the plant was killed and another one badly injured. The City of Keokuk, which is heavily dependent upon the local company, was in darkness for the best part of two nights, and one of the local newspapers, which obtained electric power from the lighting company, only got out by reason of the courtesy of its competitor. No cause is assigned by the local management for the accident, though it would appear that the gov-

ernor in some way became unmanageable and the plant was not provided with a safety-stop device.

#### Catalogue Notes

*Surface Condensers* is the title of a 24-page, 8x10½-in. booklet just published by the Wheeler Condenser & Engineering Co. The contents include an interesting chapter on the economy of running condensing, another on the advantages of the several types of condensers, followed by a description of the Wheeler surface condensers with some remarks on the relative advantages of rectangular and cylindrical shells. The Volz combined feed water heater and condenser, in which some of the tubes serve as a primary heater, is next described, after which there is a section on turbine condenser outfits. The final part of the catalog is devoted to notes and suggestions on the installation and operation of surface condensers. The illustrations, of which there are a large number, show not only the various types of Wheeler Admiralty and Wheeler-Volz surface condensers of the rectangular and cylindrical patterns, and water-works condensers, but also include a considerable number of the largest steam-power plants in this country. This booklet, which forms one of a series of engineering treatises which the Wheeler Condenser & Engineering Co. is distributing, cannot but be of interest and value to any engineer who is called upon to design, construct or manage steam plants.

*Motor Talks* is the first of an attractive series of monthly booklets sent out by the Westinghouse E. & M. Co., Pittsburgh, to central stations. It is full of hints to boost business.

*Steady vs. Unsteady Voltage* is the title of an attractive G. E. bulletin, devoted to potential and feeder regulators.

The Blake & Knowles Steam Pump Works, 115 Broadway, New York, is sending out bulletins covering mine sinking pumps, feed and tank pumps, piston pumps and vertical high-speed engines.

The Emerson Electric Mfg. Co., St. Louis, is mailing bulletins of its lines of electric exhaust fans, bipolar, direct-current enclosed motors, and single-phase motors.

#### Book Review

The *Western Electrical and Gas Directory* lists a total of 1021 plants in the States of Arizona, California, Nevada, Oregon and Washington. There is more information in it than in any other directory which purports to cover this territory, and from what

we know about it we believe its information is more reliable than any other. Unlike the average handbook, the book is printed in clear, readable type. It contains a complete list of jobbers, dealers and contractors, and members of the various engineering societies in the States. Published by Blanchfield Publishing Co., 88 First street, San Francisco.

#### Personal

Van Rensselaer Lansingh, illuminating engineer, of New York, recently delivered an address before the electrical section of the Canadian Civil Engineers' Society's rooms, Montreal. The talk emphasized the necessity of engineers and architects working together to secure proper, natural and artificial lighting of buildings.

Wm. Hand Browne, Jr., for a number of years technical editor of the *Electrical Review*, has accepted the chair of physics and electrical engineering at North Carolina College of Agriculture and Mechanical Arts. Mr. Brown before coming to the *Electrical Review* was in charge of electricity at Nebraska University for four years, and was with Morgan Brooks at the University of Illinois for three years and a half more, after which time he joined the editorial staff of the *Electrical Review*.

Meldon H. Merrill, who, as salesman for the Westinghouse Electric and Manufacturing Company, has been active for some years past in promoting the introduction of electric drive among the textile mills in New England, recently resigned his position with that company. He has taken up similar work in connection with the Boston office of Allis-Chalmers Company, which has become so large a factor in building power machinery for textile mills from the fact that it is in a position to offer any type of prime mover required, and to install the complete electrical equipment, including motors. Allis-Chalmers steam turbines have, in particular, been extensively introduced among the textile mills, and nearly every installation thus far made has led to a repeat order, showing the recognized reliability of these units for the service.

#### Trade Note

The U. S. Circuit Court of Appeals, Seventh Circuit, has reversed the lower court in its decision against the General Electric Co. and ordered an accounting for the infringement of the Knight & Potter patents by the Morgan-Gardner Electric Co.

# THE ELECTRICAL AGE

Volume XXXIX. Number 11.  
\$1.00 a year; 15 cents a copy

New York, December, 1908

The Electrical Age Co.  
New York.

ESTABLISHED 1883

Published monthly by  
The Electrical Age Co., 45 E. 42d Street, New York.

J. H. SMITH, Pres. C. A. HOPE, Sec. and Treas.  
JOHN HAYS SMITH, Editor.

Telephone No. 6498 33th.

Private branch exchange connecting all departments.

Cable Address—Revolvable, New York.

## SUBSCRIPTION RATES

United States and Mexico, \$1.00.

Canada, \$1.50. To Other Countries, \$2.50

## NOTICE TO ADVERTISERS

insertion of new advertisements or changes of copy cannot be guaranteed for the following issue if received later than the 15th of each month.

## Some Causes of Variation in High-Tension Practice

Considerable discussion has arisen, from time to time, regarding certain points of difference in the way high-tension work is done in Europe from the customary procedure in America. These differences have been made the basis of many comparisons, favorable and unfavorable to the methods used in this country; and have also led to much criticism of European practice.

However, on analyzing the variations that exist between the apparatus and methods of procedure on the two continents, it will almost invariably be found that such differences as actually do exist are based on the different conditions to be met. As an example, the differences in the design of a German and an American motor will be found to arise principally from conditions affecting the cost of labor and of raw materials as they exist in the two countries.

The custom of setting power-houses in the midst of a carefully-tended garden plot, and of finishing them architecturally in a manner worthy of their setting, is the joint result of a more highly developed artistic sense in the European engineer, and of the lower interest rate prevailing abroad. There is a famous remark of a Continental engineer regarding American bridges, power-houses and other buildings of this sort to the effect that: "It is not so much a matter of whether they would stand indefinitely, as whether they were fit to stand."

A high-tension line can hardly be rendered a thing of beauty by any sort of talent, but even in this unpromising object it may be noticed by the comparison of recent photographs that in the proportion of the towers or poles, especially where the latter are of re-enforced concrete, there is

quite a difference in the appearance of European lines. Another point that will be noticed is the less massive construction—cross-arm insulator and other details—which result in a shorter mean length of span.

The highly organized government of the states of Continental Europe has led to the taking of more stringent precautions for the protection of human life. This has long been noted on the railways, and that it has extended to transmission lines is shown in Figs. 18, 19 and 20 of the article by Mr. Koester on European high-tension practice in this issue.

Some of these precautions certainly overdo the matter—such, for instance, as the separate structure for carrying the catch-net—and it is but fair to point out that these freak constructions are, as a rule, due to the requirements of the local engineers of the districts traversed by the transmission line, rather than to the engineers of the company building the line. Satisfying the demands of these rural "polezei" engineers is not infrequently a more difficult problem than meeting those presented by nature; and a recital of the experiences of this sort that are sure to come up in the course of the construction of a long transmission line contributes to the gaieties of engineering.

But in the power-plant, where the company's engineer is, so to speak, his own master, the great care taken to safeguard the operators, and, indeed, all persons concerned, are noticed, and may be considered as well worthy of imitation in this country. The growing tendency in Europe to consider the individual as an asset of the state, has led to the proposal that corporations owning the properties on which life is in jeopardy shall be held accountable to the government, even to the extent of paying a large fine for every case of death or serious injury, whether the victim be an employee or not. This has some advantages over the custom, only too common in this country, of paying the money over to lawyers.

The milder and more even climate on the other side may help to account for the differences noticeable in certain details of high-tension work.

There is scarcely a doubt that lightning there is neither so frequent nor so severe as here. The horn lightning

arrester, which was devised abroad, and has only recently come into favor in this country, is very generally used. The addition of auxiliary gaps, as shown in Fig. 12, gives the device a much-needed flexibility in action. Another European favorite in the protection of apparatus is the "water-grounder," which is the high-tension descendant of the "tank type" of arrester used from early days in traction power-plants in this country. Why is the running-water form not more generally used in high-tension work here?

Cheap and skilled labor, under low-priced but expert technical direction, has resulted in an exceptionally fine quality of porcelain being produced abroad. This condition, in connection with the more favorable climate, has led to the use of very much smaller insulator, as may be noted by comparing catalogues of foreign insulators with those to be had in this country. There is no reason to believe that the smaller insulator—used in Europe—involves a smaller factor of safety. It is simply a matter of better quality of material and a kinder climate.

A feature, not in use in this country, so far as we know, is the portable panel shown in Fig. 15. Opinion will differ as to the value of such a scheme, particularly in high-tension work. It seems to us that the prevailing American practice of keeping the high-tension parts confined to the busses, the line itself and the oil switches, thus leaving only lower tension control and indicating circuits on the panels, is preferable from every point of view, and renders the portable panel superfluous.

In our opinion, practically all such differences in methods and details as exist on the two continents are, as above stated, directly traceable to differences in the political, climatic and economic conditions to be met, and far from being, as has sometimes been insinuated, a reproach to the exactness of engineering methods, they are really an indication of their precision and trustworthiness. For, even though starting from the same fundamental laws, if evolved under diverse conditions, a difference in the results of the development is exactly what ought to be expected, and is what has taken place.

**Some Developments in the New  
York, New Haven & Hartford  
Single-phase Electri-  
fication**

"The play's the thing."

—Hamlet.

The advance copy of a paper giving a number of interesting facts about the working of single-phase electrification in heavy railroad operation, as installed on the New York, New Haven & Hartford Railroad between Stamford, Conn., and Woodlawn, N. Y., furnishes very instructive reading for those who are following up the application of electricity to the operation of trunk line railroads.

As the interest in the possibilities offered by the use of the electric locomotive in this class of service is as widespread as in any problem now before electrical engineers, we have noted some of the prominent features of the paper presented to the American Institute of Electrical Engineers by Mr. W. S. Murray, electrical engineer for the New Haven Railroad.

For the very full and frank presentation of the faults developed in the trying out of this, the pioneer application of single-phase alternating-current to trunk line railway work, the engineering public is under great obligation to the New Haven management as such confession has not been heretofore common in the history of similar work.

The considerations which led to the adoption of the comparatively untried single-phase system for the work under consideration instead of using the familiar alternating-current-rotary-substation-direct-current scheme so ably applied on the terminal electrification of the New York Central Railroad, are so familiar that they need not be recapitulated here. In a word, single-phase electrification was simply the general solution of the problem of future operation with economy—not merely of the terminals but of the whole system.

That, even with this ultimate end in view, the decision reached was erroneous—as has been somewhat vociferously claimed by many engineers—it is, in our opinion, entirely too soon to judge. For in the last analysis, if the popular though sound definition of good engineering as the "making a dollar go the farthest," is true, it is by the balance-sheet that all engineering questions must be judged. And the balance sheet must hold all the items—which in this case is not yet possible.

To return to the story: On the principle that the first duty of a railroad is to keep the trains moving,

the number of delays is at first glance the most discouraging feature presented. The entire passenger service of the road was taken over for electric operation on July 1, 1908. In the four months subsequent to this date the train-minutes delay on the New Haven road, due to one electrical cause or another, totalled somewhat over 5000. This is counting the delays of over 300 consecutive train-minutes at 300 as the author has reckoned. So the estimate is under rather than over the actual amount, and does not count in the delay due to the wreck of the White Mountain Express on July 16. As to what percentage of the total train operation these figures represent the paper gives us no hint, but as the statement is elsewhere made that the electric service "far surpasses the steam service it supplanted," we may infer that—formidable as the above figures look in the lump—they do not constitute a large percentage when figured in on the entire train movement.

The cause of these delays during the period of 123 days covered by this record may be classified as follows:

Cause.	Times.	Train Minutes.	Approximate Per Cent.
Power-plant.....	2	133	2.6
Lines.....	50	3422	66.8
Locomotive.....	81	1557	30.6

From this it is apparent that the bulk of the delays are chargeable to the line. It is curious to note in this connection that this is what might be expected, as the line and line accessories are more radically different from previous practice than either of the other principal features. Considerably over half of the line delays are due to failures of one item—circuit-breakers. With the improvement of this feature, therefore, there is good ground for expecting an enormously better performance on the line.

Locomotive failures are, in the nature of the case, less serious than line failures. While there are too many locomotive failures shown, it is encouraging to see that they are confined almost entirely to the accessory apparatus and should be easily and cheaply corrected now that they are located. We see no more mishaps of this sort than would naturally be expected in operations of this sort which lie so far outside the scope of previous experience.

The history of the installation and operation of this single-phase electrification so far, when all the conditions are given their proper credit,

does not seem to justify the savage criticisms of it that are heard from time to time.

That these attacks have touched the management of the road, as well as the contracting companies, cannot be denied. A fair portion of Mr. Murray's paper is devoted to a modest depreciation of them and in more ways than one is evidenced the sensitiveness that even the best-balanced temperament will come to feel under a long-continued front and cross-fire of this sort—especially when it is convinced that a large proportion of it is based on snap impressions and prejudice.

We advise that those who sit in judgment on the New Haven electrification take the wide view and grant the stay of judgment that the tremendous importance of the case demands.

It seems to us that there has been a notable lack of perspective. We have been too close. Instead of judging single-phase electrification, under these conditions, as a whole—and always with reference to the balance-sheet—there has been a tendency to look too closely at relatively insignificant details. The weight and minor details of the locomotives, the sparking of the trolley, the failure of circuit-breakers and a similar list of minor matters, extending back to the turbine troubles in the power-house, have been filling the vision of critics, instead of the calm, dispassionate view of the results from draw-bar to coal-pile. The details and the train delays, the annoyance and the expense that have resulted from their lack of proper adjustment to a thousand new and conflicting conditions are absolutely incidental and evanescent. To judge the ultimate issue by them is precisely analogous to judging the modern finished locomotives by the model of 1850 or present steam turbine performance by the standard of five years ago. This is the first attempt of its kind—time is absolutely essential, nor does the first cost of the first effort determine anything more than the maximum cost. Critics should remember that the first National Cash Register is said to have cost \$50,000. To-day the cost is nominal.

We submit that train delays on the New Haven road incidental to the first period of its operation have no more bearing on the ultimate perfection of single-phase operation as a whole than the Kingsbridge wreck had on the direct-current problem. Both were unfortunate incidents—and incidents only. Both are unlikely to be repeated in after years.

It is urged that the single-phase installation has cost as much or more than the accomplishment of the same end by a direct-current installation. It may be expected as an initial installation it would do so—yet we have an idea that when the balance-sheets are compared after a reasonable length of time the difference may not be as generally forecasted. Granted, however, that the initial cost has been somewhat higher, there are two immense offsets to the increase. First, the next and all succeeding installations will cost far less than their present installation and less than any long-distance direct-current system; second, the operating experience is invaluable, considered in its bearing on the electrification of the other portions of the New York, New Haven & Hartford's system.

It should hardly be necessary to point out that with a direct-current installation in place of the one that was adopted, the art of applying electricity to the operations of trunk line railroads would be just where it was two years ago—save perhaps that some lesson would have been learned in holding down first costs by avoiding too much power-plant and too much engineering.

When the electrification of the New York Central was proposed the first step was to get together a commission of eminent engineers to make recommendations and to supervise the construction of the work. These gentlemen recommended a duplicate power-plant and practically a duplicate line and the New York Central built a second power-station at a cost of considerably over a million dollars. The power-plant has lain idle these eighteen months, never having been called upon to supply current to the system and probably never will until the projected system is extended to Albany. When this is done its geographic situation is wrong. In the light of present knowledge we believe that the commission would acknowledge this as a gigantic engineering blunder and a waste of capital. We might discuss other early work of the road, but this is sufficient to show the futility of advance criticism. Our purpose is not to criticise, not to establish the infallibility of engineering of any brand, but to show that new engineering work always involves more or less experiment and the getting of experience. Wise engineering merely minimizes the cost of experience. As a result of the New York Central commission's work the road is now operating in a satisfactory manner at a total cost per kilowatt-

hour at the rail contact of about 2.4 cents, which figure we believe to be about double that of the New Haven road!

These considerations ought to answer the numerous charges relative to experimenting on a large scale. That the New Haven people will ultimately be able to make a balance sheet showing and justifying the confident stand taken by them at this time, we sincerely hope and believe.

In the meantime let us stand back from peering too closely at the pattern of the building blocks—and take a high and wide view of the completed structure and judge it by the expenditure from draw-bar to coal pile—and when the installation shall count its trackage by the thousands instead of the hundreds.

And while we suspend judgment, we need not withhold a tribute of admiration of the foresightedness of those who have tried to look beyond the distances of a terminal section and the time of to-day and make an intelligent provision for the operations of a great system and the traffic needs of to-morrow.

#### The Return Circuit

One of the peculiarities of the development of electric traction in this country has been the slow awakening to the importance of the return side of the trolley circuit. Not a few of the early roads were built without any sort of bonding and it was only installed when the failure of the cars to make schedule time made it absolutely necessary. And as a rule it was then done grudgingly and in a cheap and inefficient manner.

Even to-day, after twenty years of experience, it is not unusual to find suburban and interurban roads on which the bonding is far from being on a par with the rest of the equipment. There are lines that have been most generous in the matter of feeder copper, and are operating expensive substations, that are wasting their output in heating up poorly bonded joints, or worse still in eating up their rails. This latter aspect of a defectively bonded track, along with many others of the more common disadvantages resulting from the failure to properly take care of the return circuit, is pointed out in Mr. E. G. Hindert's article on "Suburban Electric Railway Return Circuits," in this issue.

The statement that electrolysis in some cases has worn away the base of the rail more than traffic has worn the head has been verified many times. In one instance a bad derailment was caused by a broken

girder rail, nearly all of whose base and much of the web was eaten away by the leakage of return current to a large water pipe running across the right of way and forming a short-cut return circuit to the power-house. In another case the partial failure of the anchor of a suspension bridge was caused in the same manner. Numerous scares from the freaks of return currents, caused, for the most part, by poor bonding, have occurred in the last few years.

Experience shows under ordinary conditions that a track, well bonded and well looked after will take care of all but a few per cent. of the current which may be turned into it from the car-wheels. The exceptions are: where the traffic is so extraordinarily heavy that the current density in the rails leads to large voltage drops or where the configuration of the line is such that large loops are formed with the power plant or substation in an unfavorable position relative to the loop.

But with a track once well bonded the upkeep costs should not be large. No feature of the traction layout has been the subject of more discussion than the various types of bonds. Riveted, compressed, expanded, soldered and plastic bonds, either protected or unprotected have been tried out on a large scale and none has given any great degree of permanency. The life of the bond, as pointed out by Mr. Hindert, depends quite as much on the way in which the track is kept up as on the type and manner of application of the bond. After years of experiment the electrically brazed bond seems to be the best from the point of view alike of cheapness of installation and length of life.

Large quantities of this type—which has only recently been brought to a high degree of perfection—are being installed on the principal traction systems of the country. Although a special outfit is required to do the brazing, on a road of any considerable size the greater cheapness and quickness of installation, of the bond itself makes the total cost per bond compare favorably with that of the older types. With the proper degree of heating, a perfect union of the steel of the rail with the copper of the bonds seems to take place, and so secure is the junction that only the most violent treatment will break it.

At present this bond has no real rival in the field, and its use bids fair to settle the long standing questions as to what bond should be used on the ordinary track return circuit.

### Output Costs of the Isolated Factory Plant

In our last issue we presented an estimate of the output cost of a typical 25 h.p. gas-engine installation, showing that, for furnishing power under given conditions, the monthly cost was about \$83.60 as compared with monthly cost, for a similar motor service of \$98.74, based on a charge of 3 cents per kw-hr.

This estimate was based on a fuel cost of gas at 80 cents.

Let us examine the effect of installing a small producer. The fuel item would be considerably reduced, while the fixed charges and labor would be augmented. Such a plant would figure out somewhat as follows, hard coal being used in a plant of this capacity:

*Price complete, \$2500.*

For 100,000 cu ft. at 30 cents.....	\$30.00
Oil, Waste and Incidentals.....	5.00
Repairs.....	5.00
Interest and depreciation.....	30.00
Labor.....	50.00

Total monthly cost..... \$120.00

For so small a plant the producer costs very high, increased fixed charges and labor eating up the fuel economy.

For a comparison of the cost of a steam plant on the same basis we find:

*Cost of a complete 25 h.p. steam plant (erected), \$1000.*

Coal, 18 tons at \$2.50.....	\$45.00
Oil, waste and packing.....	2.50
Repair.....	4.50
Labor.....	50.00
Interest and depreciation at 10 per cent....	8.33

Total monthly cost..... \$110.33

This is considerably higher than the cost of motor service, but if steam heat be utilized for seven months of the year the monthly cost chargeable to power falls off to about \$85.00 as pointed out in our October issue. This figure shows a saving of some 14 per cent. as compared with the electric service, and indicates that even for plants of this small size, where the heating question enters at all, it is one of the important factors.

The foregoing considerations are principally applicable to small power plants, such as would be installed in small factories, where the power load is the principal one, and represents the lower capacity limit, under the assumed conditions, for the installation of a separate plant where outside service is available.

From this point upwards the separate plant, makes a continually improving showing. Let us look at a plant of 500 h.p. connected capacity.

There are so few modern factories using this amount of power that do not employ motor drive that we think it fair to introduce here the

electrical generator and its auxiliaries. We therefore present the following estimate of power service for such a plant, based on about 65 per cent. station load factor at 3 cents per kw-hr., as compared with the output cost of a 500 h.p. producer gas-driven electric plant and a 500 h.p. steam-driven plant:

*Necessary installation, distributing switchboard and connections cost \$250.00.*

Power cost—2450 kw-hr. x 25 days x 3 cents per kw-hr.....	\$1,837.50
Interest and depreciation.....	2.08

Total monthly cost..... \$1,839.58

This assumes the power measured at the distributing switchboard.

Monthly cost of 500 h.p. producer gas-driven electric plant:

*Cost of complete plant erected, \$45,000.*

Operating cost on 10 hour basis. Daily load and full consumption as follows:

Full load, 2 hours = 700 kw.-hrs at 1½ lbs. = 1225 lbs.	
¾ " 4 " = 1050 " " 2 " = 2100 "	
½ " 4 " = 700 " " 2½ " = 1575 "	
Totals 10	2450 4900 "

Monthly coal consumption, 4900x25  
2000 = 61.25 tons

Monthly cost for fuel, including stand-by losses at \$2.50 per ton.....	\$160.00
Supplies, oil, waste and miscellaneous....	40.00
Labor.....	125.00
Depreciation and repairs at 7½ per cent....	299.00
Interest.....	188.00

Total monthly cost..... \$812.00  
Total number of kilowatt-hours per month. 61,250

This amounts to 1.34 cents per kw-hr. and is considerably less than half the cost of power at 3 cents per kw-hr.

Considering now the output cost of a steam plant of equal capacity supplying the same load and not considering the heating question, we find:

Monthly cost of complete 500 h.p. steam-driven plant including direct-current generator and switchboard:

*First cost of plant, \$36,000.*

Monthly cost of 260 tons, at \$2.50 per ton....	\$650
Supplies, oil and waste.....	20
Labor.....	200
Depreciation and repairs at 7.5 per cent....	225
Interest at 5 per cent.....	180

Total monthly cost..... \$1,275

This amounts to 2.08 cents per kw-hr. and shows that even if the heating factor is not considered it is still justifiable to consider current at 3 cents per kw-hr.

The question as to exactly the amount of saving introduced by the economical use of a heating system fed from the same boilers with exhaust, or exhaust and live steam has been discussed at length by the American Institute of Mechanical Engineers and elsewhere. It naturally varies considerably and each case is a study in itself, as indeed is the whole problem.

### Austin Municipal Plant

The water works, electric light and power plant of the City of Austin, Texas, is installing an Allis-Chalmers steam turbine generating unit. For some time the power facilities of this municipal station have been entirely inadequate and the purchase of additional machinery was imperative. At the present time a generator direct connected to an Allis-Chalmers 400 h.p. tandem compound engine is furnishing the current. The load on the unit is frequently so great as to require transferring part of it to an 800 h.p. compound Corliss engine now being used to drive a number of small dynamos. This engine propels a large steel shaft by means of rope-drive, and, with the aid of several friction clutches, about one-half of the power is transmitted to the dynamos. The procedure of transferring the loads, nightly, has caused considerable inconvenience and results in a wasteful expenditure of fuel and wear of machinery. The turbine is a 500 kw. 60-cycle, 3-phase, 2300 volt machine, designed to run condensing at a speed of 3600 rev. per min., of the horizontal, multiple-expansion, parallel, all-around flow type, with patented special construction of blading and other features. In connection with this equipment the city of Austin has also purchased from Allis-Chalmers Company a 22½ kw. exciter, to be driven by a vertical engine, and a large line of that company's Type AL lighting transformers.

### Pennsylvania Terminal Electrification

On the eve of Election Day the Board of Directors of the Pennsylvania Railroad Company awarded the contract for the electrification of the New York and Jersey City Terminal to the Westinghouse Electric & Manufacturing Co. This, although one of the largest electrical contracts ever let, represents only the first expenditure on the electrification of this section, which extends from Harrison, N. J., to Jamaica, L. I. The locomotive portion of the contract is said to include 100 direct-current electric locomotives, which will be furnished by the Baldwin Locomotive Works, and will be the largest and most powerful yet constructed. They are designed to handle a traffic amounting in the near future to 500 trains a day and will be capable of hauling the loads up the tunnel grades at high speed. It is also stated that 250,000 h.p. will be required to operate the terminals.

The contract is to be completed in 20 months.



# Some Features of European High-Tension Practice

By FRANK KOESTER\*

EUROPE, where high-tension transmission systems originated, although not possessing as extensive systems as are common today in America, has many novel features, not only in transmission line construction, but also in switch gears. As many of these features are uncommon in American practice, the purpose of this paper is to give some points of European practice along these lines. However, it must not be taken for granted that all of the various features touched upon are of strictly European origin.

Starting with the wiring diagram, after which the general arrangement of the switching room is laid out, the systems are usually very complex, considered from an American point of view. One will find the greatest variations from the non-bus to double bars, or the double-ring bus system so commonly found in Swiss practice. To go directly to the point, Fig. 1 is submitted, which shows the wiring diagram of the Obermatt plant of the Lucerne-Engelberg, 27,000-volt transmission system, one of the recent and prominent Swiss installations.

Aside from a single generator set for railroad purposes, shown isolated at the left of the main diagram, the four generators supply current both for light and motor power, through a three-phase distribution system. Each of these four generators, designed to supply 1850 k.v.a. three-phase for power purposes, or 1380 k.v.a. single-phase for lighting, generates at 300 rev. per min., 6000 volts at 50 cycles with 100 volts excitation.

The generator voltage is stepped up to 27,000, either by one single-phase transformer, or a group of three for three-phase transformation. There are two groups for three-phase transformations, between which is a reserve transformer, used when one of the groups is out of commission. The current of any generator may feed the single-phase transformers, or may be sent through the three-phase groups, for which purpose two ring systems are installed on either side of the transformer, one being single-phase, the other three-phase.

From the station lead three outgoing lines, one for "Light Lucerne," one for "Power Lucerne" and the other for "Light and Power Unter-

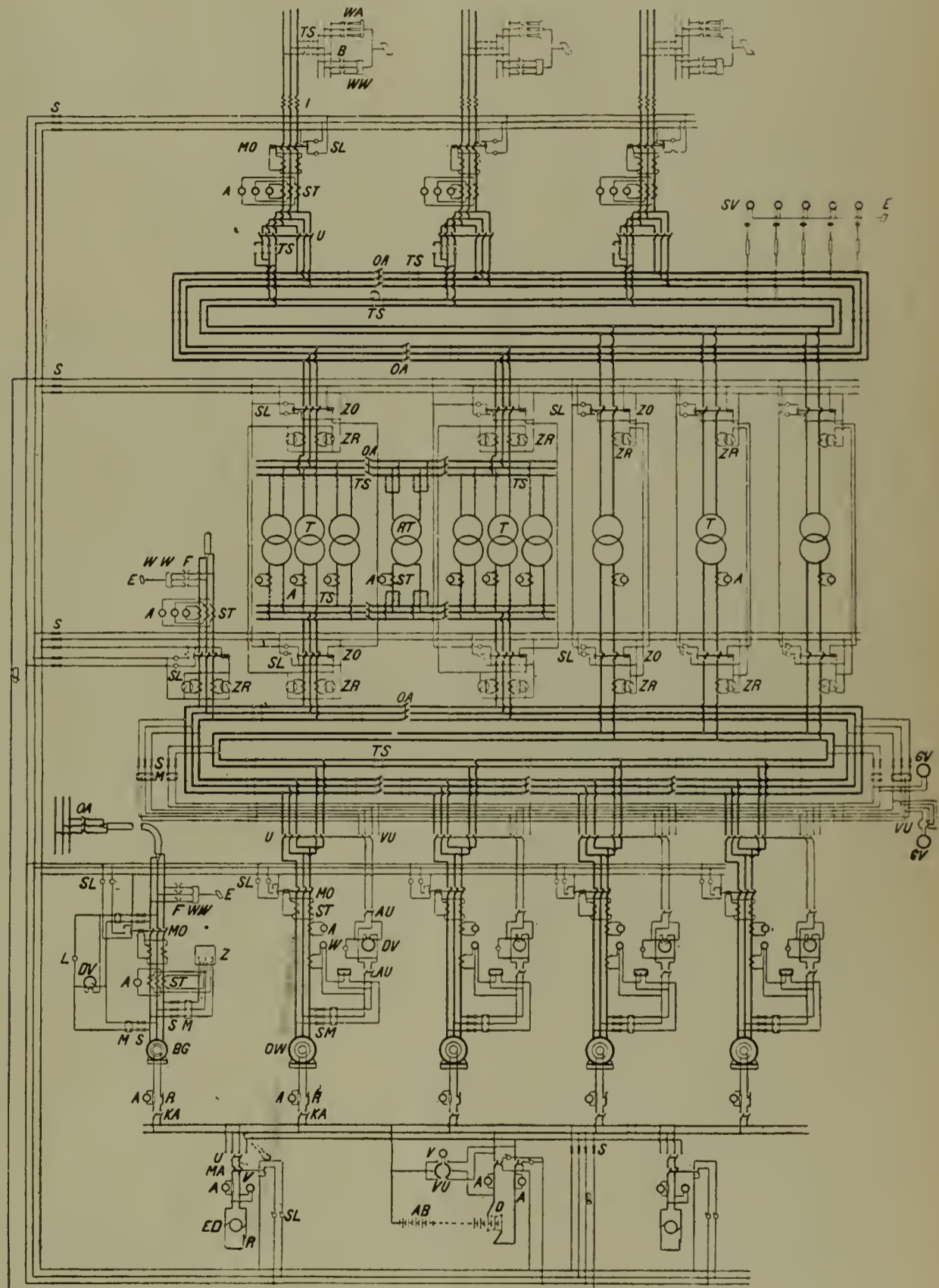
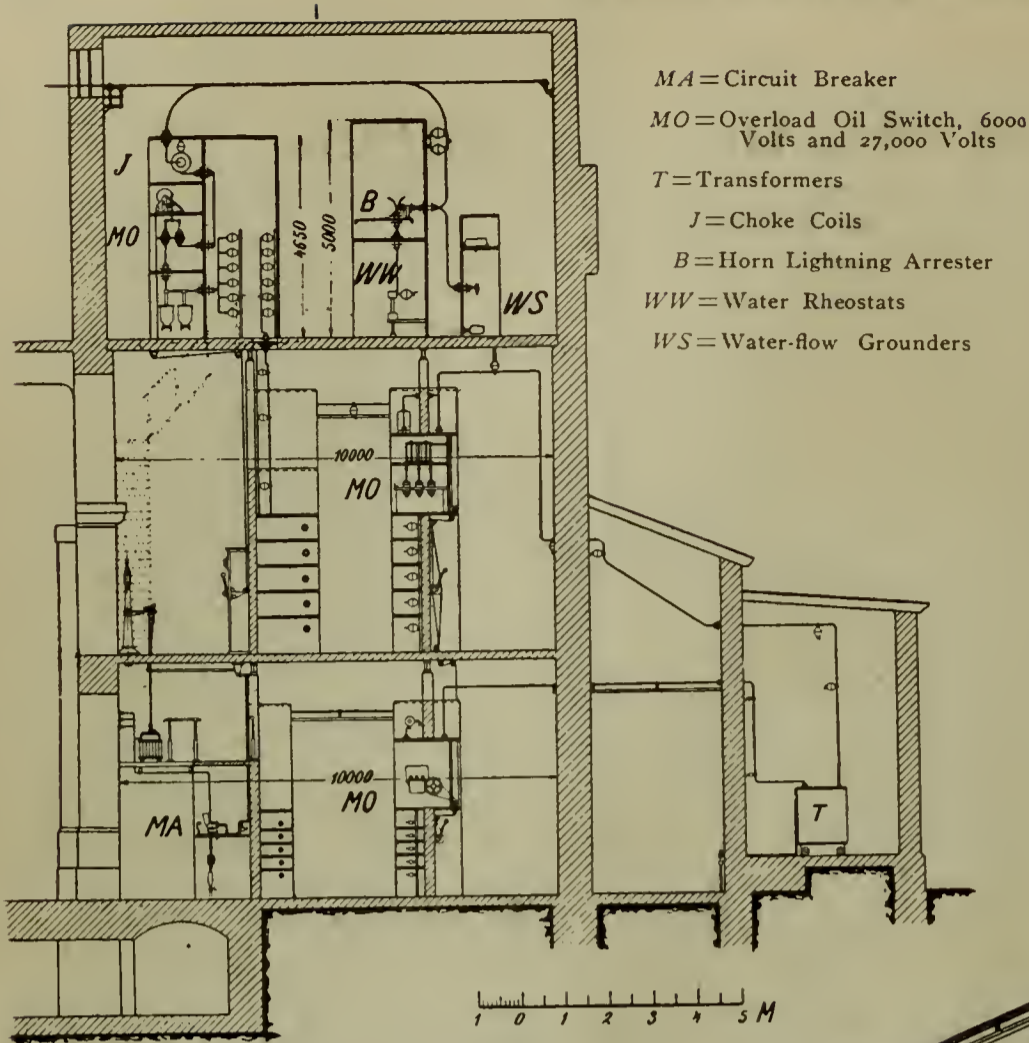

Fig. 1.—WIRING DIAGRAM OF POWER PLANT, OBERMATT, SWITZERLAND.

ED=Exciter Generator	U=Double-throw Switch	SL=Signal Lamp
BG=Railway Generator	VU=Volt-meter Switch	WW=Water Rheostat
DW=Three-phase Alternators	D=Double-cell Switch	B=Lightning Arrester
T=Transformers	TS=Disconnecting Switch	F=Lightning Arrester
RT=Reserve Transformers	S=Fuse	I=Choke Coils
M=Measuring Transformers	A=Am-meter	WA=Water-flow Apparatus
AB=Storage Battery	ST=Series Transformer	E=Earth Plate
R=Regulator	V=Volt-meter	Z=Three-phase Am-meter
AU=Cut-out Switch	DV=Double Volt-meter	ZO=Maximum Oil Switch, with Time Relay
KA=Carbon Cut-out Switch	GV=Static Volt-meter	ZR=Time Relays
MA=Overload Switch	W=Watt-meter	
OA=Sectionalizing Switch	L=Phase Lamp	
MO=Overload Oil Switch		

\*Consulting Engineer, New York.



- MA=Circuit Breaker
- MO=Overload Oil Switch, 6000 Volts and 27,000 Volts
- T=Transformers
- J=Choke Coils
- B=Horn Lightning Arrester
- WW=Water Rheostats
- WS=Water-flow Grounders

increases], the above wiring diagram copes admirably well with such conditions. However, such a system demands a large building to house the switching apparatus, which increases the first cost as well as that of maintenance.

There are many Continental plants which furnish good examples of the general layout of modern switching rooms. Fig. 2 shows a cross section of the switching room of the above-mentioned Obermatt plant. Starting on the opposite side of the main generating floor, the compartment "M A" contains the circuit-breakers. On the gallery above are located the field rheostats, operated from the generator instrument column on the floor above, from whence the whole generating room is overlooked. Compartments "M O" contain the overload switches and buses for 6000-volt and 27,000-volt circuits. The transformer compartment "T" is provided with an elaborate circulating water piping system, controlled by an auto-

Fig. 2.—CROSS SECTION OF SWITCHING HOUSE, OBERMATT HYDRAULIC PLANT, SWITZERLAND.

walden." The current for Lucerne is led to the substation Steghof, 27 miles away in the neighborhood of Lucerne. For both "Light Lucerne" and "Power Lucerne," two three-phase lines are used; under ordinary conditions, one of the phases of the "Light" line is dead. The switching gear is so arranged that single- or three-phase current can be sent over either of the circuits, and the dead wire is in reserve in case one of the others is rendered inoperative.

The city of Lucerne demanded additional single-phase light free from fluctuations, which would not be given if motors were connected to the same circuit. To meet this condition the light and power loads are kept on independent circuits.

A similar system will be found in the power plant of the Vandoise Motor Power Co. on the Lakes Jonx and Ober, Switzerland. The five generators in this plant feed two three-phase ring systems and one single-phase.

Such arrangements may seem complicated on the surface, but after thoroughly studying them, the great flexibility is apparent, particular when one keeps in mind that the current is supplied for various purposes by a few generator units. Further, when the nature of the future load cannot be ascertained, and the day and night load is irregular throughout the year; [in summer time the light load decreases, while the railroad load, particularly in mountainous countries,

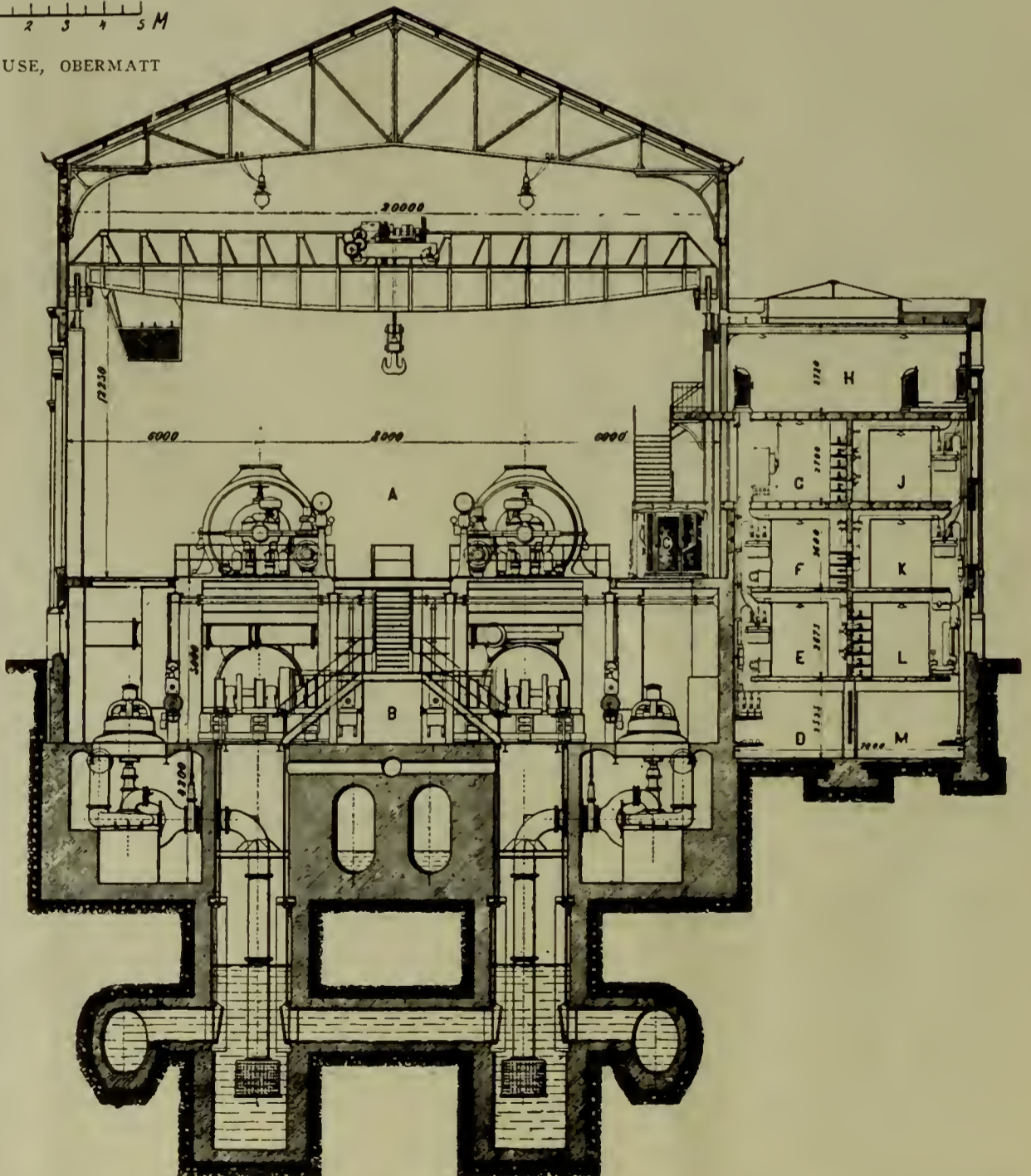

Fig. 3.—CROSS SECTION OF GENERATING AND SWITCHING ROOM, ST. DENIS PLANT, PARIS, FRANCE.

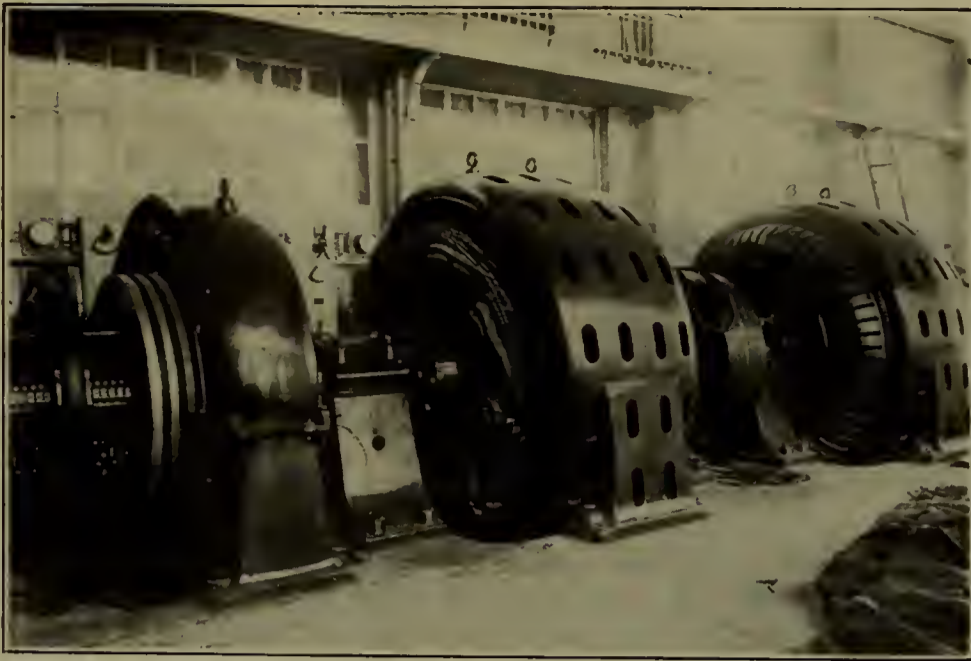

Fig. 4.—POLYMORPHIC SET, ST. DENIS PLANT, PARIS.

matic signal device. "B" are horn lighting arresters, connected to water rheostats "W W." The same floor also contains the water-flow grounders "W S." and the choke coils "J."

This upper floor is devoted exclusively to apparatus for outgoing lines, and occupies only a small portion of the switching building. The switchboard for same is located in the rear of the instrument columns on the operating gallery. The two lower floors are divided up by partition walls into six separate rooms, with ample space between the various buses, switches, etc. All bus bars are exposed, there being no partition between the individual phases. The only partition used is to separate the single and three-phase circuits. Such a lay-out is provided for both circuits, the 6000-volt and 27,000-volt. Of course, arrangement of this kind can be made only by having sufficient passageway for safety.

There are several Swiss hydroelectric installations, as well as substations, laid out on a similar scheme.

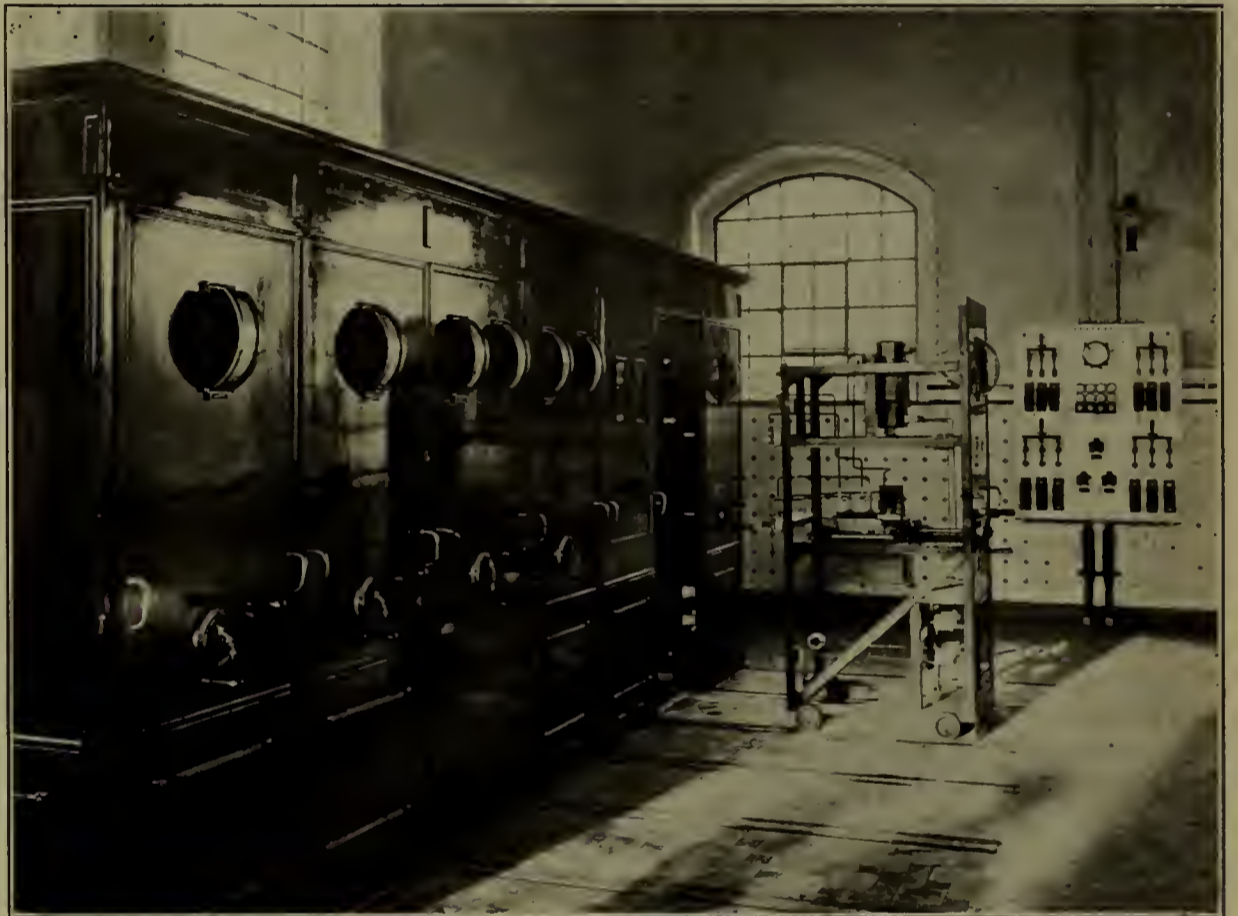

Fig. 5.—SIEMENS-SCHUCKERT WAGON-PANEL SWITCHBOARD.

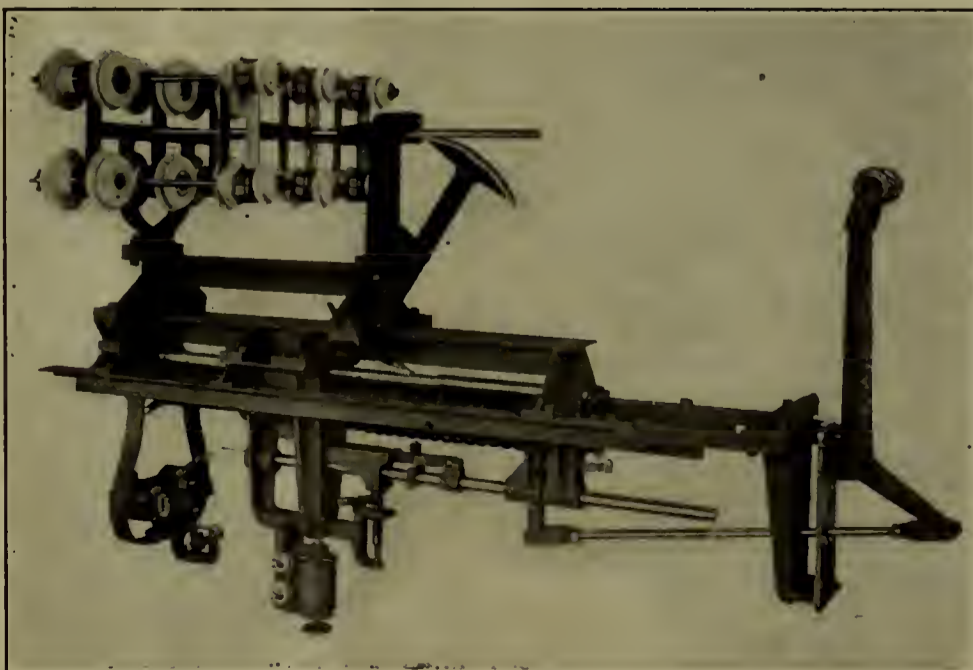

Fig. 6.

This practice is not confined to hydraulic plants alone, but is also found in steam plants, an example of which is given in Fig. 3, showing the cross section of the generating and switching room of the St. Denis Power Plant, Paris. This plant is not only the largest one in Europe, but also the largest Parsons turbine station in the world, and is known to possess many novel features not found in American practice, particularly on the mechanical end, which, however, cannot be treated here, as this article is confined to switching practice only.

Commencing with compartment "D," which contains the generator leads, the current flows in alphabetical order, the apparatus being located as follows: "E," main generator switches; "F," main bus bars;

"G," rheostats; "H," taking up the entire floor, contains the controlling bench and the outgoing feeder controlling and switch-bench. No high-tension current gets into the upper compartment, but is carried across to compartment "J," where the feeder switches are located. Compartment "K" contains the bus-bar junction switches, while "L" contains potential regulators. The last and lower compartment, "M," serves for the outgoing underground cables. There is a switchboard "C" located in the main generating room, beneath the staircase leading to the controlling bench room. This switchboard is equipped with instruments required for control of the exciter units, motor-generator sets, booster and a polymorphic group.

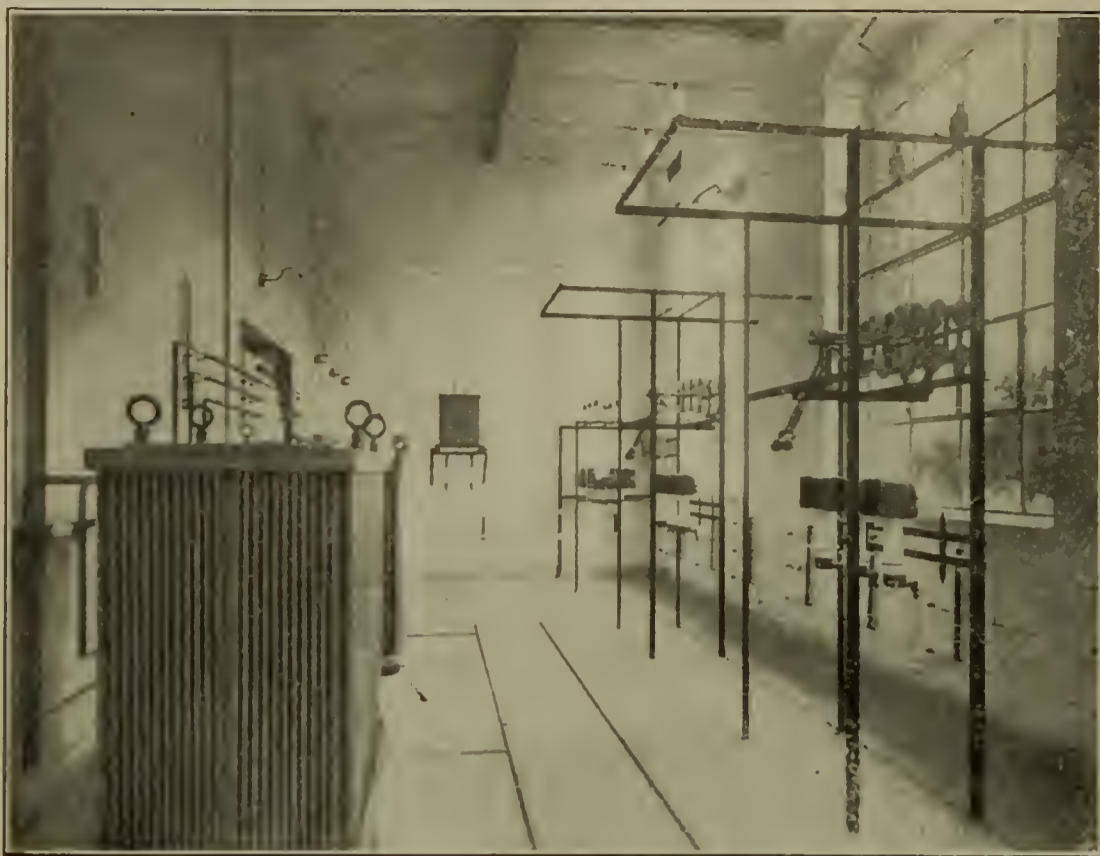

Fig. 7.—INTERIOR OF TRANSFORMER STATION, SCHAFFHAUSEN, SWITZERLAND, SHOWING AIR-BRAKE SWITCHES AT THE RIGHT AND LIGHTNING PROTECTING DEVICES IN THE REAR.

This polymorphic group consists of four different machines, two motors and two generators, mounted on two shafts, coupled together. On either end is a 550-volt direct-current generator, between which is one three-phase, 25-cycle, 10,250-volt alternator, and one two-phase, 42-cycle, 12,300-volt alternator, which can also supply 6150 volts. In the middle of the group is an electro-mechanical operated clutch coupling, making it possible to use the group in two sets. The two alternators, each having a capacity of 750 kw., may operate together under a load of 1500 kw. on the 550-volt service. It is also possible, with this group, to balance the load on the two alternating systems, by running the 25-cycle or the 42-cycle machines, or either one, or both of the direct-current machines as motors.

Controlling benches in Europe are not found in such general use as in America, but where they are they contain not only pilot switches, signal lamps, etc., but rheostat wheels and instruments necessary for the control of generators and outgoing feeders.

The structure of these benches is structural steel, forced with pressed or rolled steel plates. The sloping top is either of metal or white marble; slate or soapstone is little known in switch-gear practice. The dial-faced instruments are usually set flush with the top, while the edgewise instruments are set so they project above the surface. Although these benches are sometimes made entirely of metal, there is no danger to the operator, as the structure is well insulated.

Another novel feature in Continental switchboard practice is the wagon-panel system. In the Siemens-Schuckert design, the entire panel and its equipment is built on a structural steel wagon, the rollers of which run on tracks. The design of the Allgemeine-Elektricitäts Gesellschaft consists of a small carriage containing the removable part, running on tracks on the structural steel frame of the switchboard. When the panel is to be removed a portable wagon is backed up, the latter is pulled out and the wagon removed. The movable panels in both systems are provided with locking devices, and cannot be withdrawn while they are in operation. The electrical connections are made similar to knife-blade switches, consisting of heavy clips, which make and break the circuit when the panel is rolled in or out.

The principal advantage of the wagon-panel switchboard is that a panel can be withdrawn for inspection and repair, and a reserve panel shifted in without disturbing the operation of the remaining units; thus the dangers and delays otherwise encountered are eliminated.

The designs of switches vary greatly in many respects from those in American practice; however, there is no definite line of demarcation between the various types. Fig. 6 shows a 10,000-volt, 150-ampere, three-pole air-break switch, with automatic tripping device. In recent years it has found much favor in French and Swiss hydro-electric power plants. The make and break is made in a hollow porcelain cylinder of small

bore. When the circuit is broken the arc formed expands the air so suddenly as to cause it to be extinguished by the induced draft. The application of this type of switch in a more simple design is seen in Fig. 7. Frequently these switches are placed on the floor below the switchboard, and operated from same by means of levers and steel cable.

Fig. 8 shows a 30,000-volt, 300-ampere oil switch, with an electromagnetic tripping device, a type common in equipments furnished by the Oerlikon Co., who also designed the previously mentioned type. A striking feature is the small oil cells. The switch in practice is set in an open concrete cell, the steel framework being removed.

A Siemens-Schuckert 6000-volt oil switch, with two current blowouts and one voltage relay, is shown in Fig. 9. They are usually set on a framework of the switchboard, or on the floor beneath same, and operated from the board by levers, sheaves and steel cables. They are installed for voltages up to 20,000; above this the phases are placed in separate oil tanks. In the latter case they are motor-operated, as will be seen in Fig. 10, showing the 35,000-volt switching room of the Heimbach plant, Germany.

As already stated, most of the high-tension apparatus is placed in open

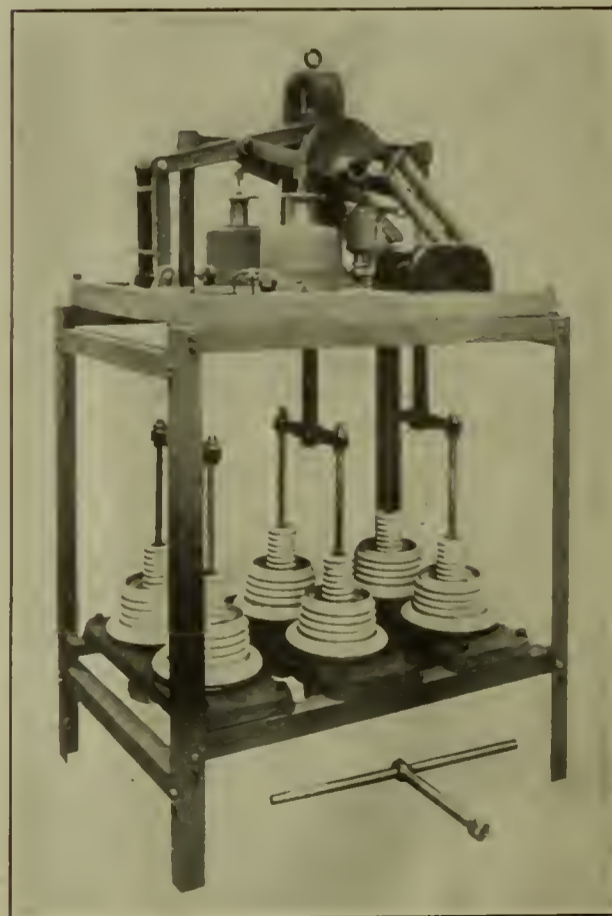

Fig. 8.

compartments exposed to view, and the contacts of many high-tension switches are placed in a single oil tank; such an arrangement is seen in Fig. 11, showing 11,000-volt and

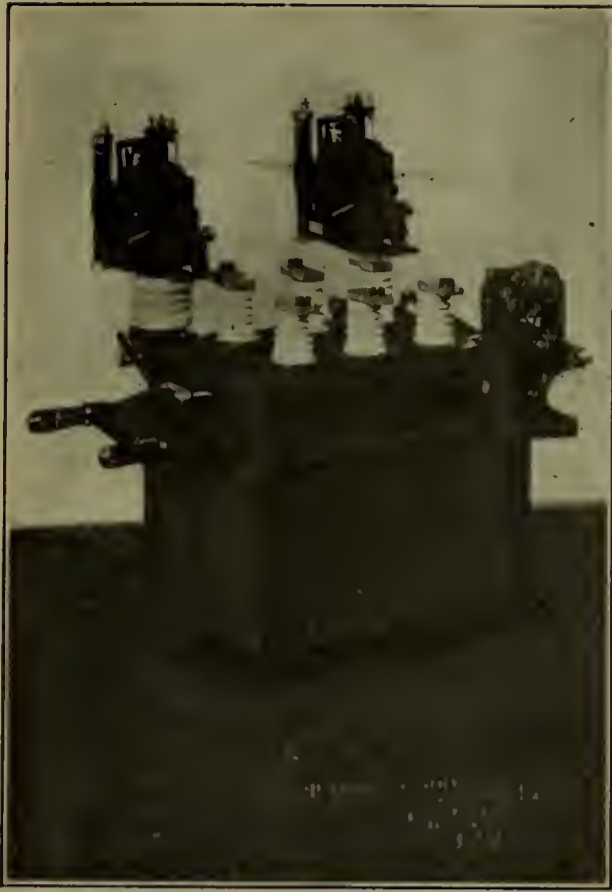

Fig. 9.

50,000-volt oil switches in a substation at Castellanza, Italy.

The types of transformers are practically the same as found in American practice; however, it may be of interest to give here some data on a high-voltage, air-cooled transformer as installed in an Italian substation at Lomazzo, where there are a number of 1250 k.v.a. 42,000- and 11,000-volt single-phase transformers. The peculiar feature of these transformers is that the cores are not encased, but placed in masonry compartments, through which air is forced from ducts beneath. The front of the compartments is cut off by a rolling shutter, and the air is discharged through the roof ventilators of each compartment. The reason given for this design is that ready inspection and repair can be made, although when extensive repairs are required the transformers are removed to the repair shop. The manufacturers, Alioth, Münchenstein, Switzerland, guarantee the following efficiencies:

Regulation at 1.00 power factor full load	1%
Regulation at 0.80 power factor full load	3%
Regulation at short circuit	3%
Efficiency, full load	97%
Efficiency, half load	85%

The operation of the blowers is included in these efficiencies.

The horn-type lightning arrester, so prominent in European practice, is always found in connection with auxiliary apparatus such as choke coils of the various types, oil and water rheostats, and especially water-flow grounders. The oil rheostat is similar in principle to the electrolytic ar-

rester recently introduced into American practice.

Frequently horn-type lightning arresters are also equipped with other auxiliary devices; for instance, the Siemens-Schuckert relay horn lightning arrester has, in connection with it, condensers, Tesla transformers, automatic blowout, etc. The horns are placed three to four millimetres apart, which is the lowest practical setting, because dust or other particles may collect and cause it to discharge with a closer one. The gap of three to four millimetres will cause the arrester to discharge, under ordinary operating conditions, at 8000 volts, but with the use of the auxiliary apparatus it will discharge at 3000 volts and lower without changing the setting of the horns. This is accomplished by the discharge of an auxiliary gap set off by two condensers, as shown in Fig. 12. The auxiliary discharge causes high frequencies in the Tesla transformer which starts the main gap.

Another application of the Siemens horn is shown in Fig. 13. It consists of a series of gaps connected to several layers of choke coils which, in turn, are connected to oil rheostats.

Water-flow grounders are very much



Fig. 10.—35,000-VOLT BUS-ROOM, SHOWING ALSO MOTOR-ACTUATED OIL SWITCHES, HEIMBACH PLANT, GERMANY.

used in Continental practice, and one will find them on practically every

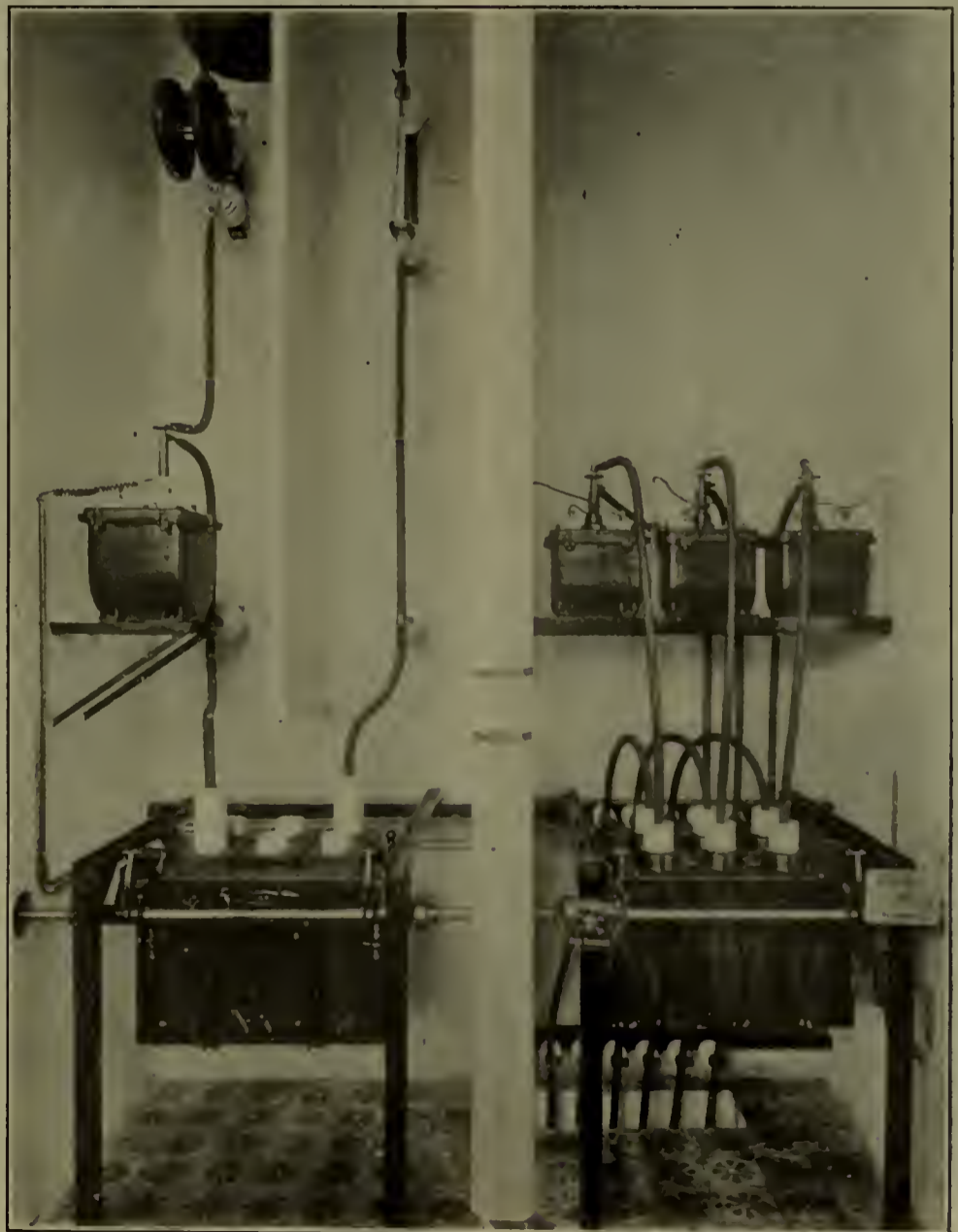

Fig. 11.—11,000- AND 50,000-VOLT SWITCHES AT A SUBSTATION IN CASTELLANZA, ITALY.

high-tension system. The water in a hydraulic plant is drawn from a

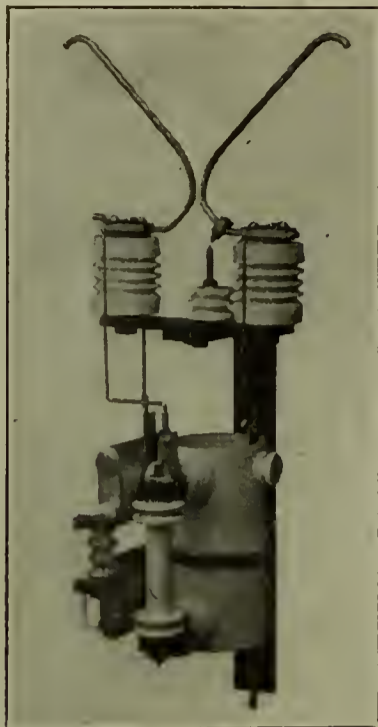

Fig. 12.—SIEMENS-SCHUCKERT LIGHTNING ARRESTER, WITH AUXILIARY GAP AND RELAY.

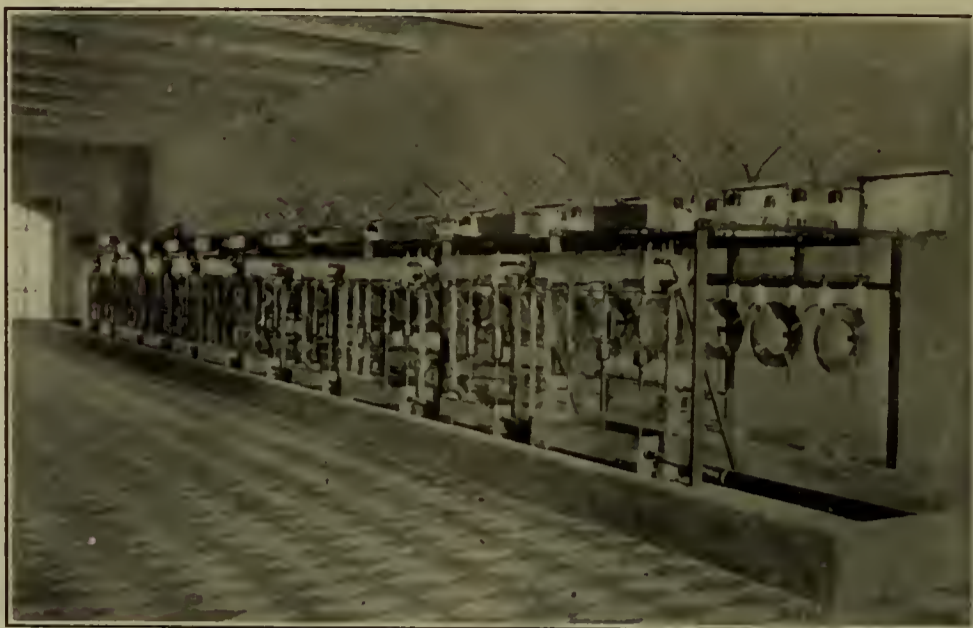

Fig. 14.—BANK OF LIGHTNING ARRESTERS, CONSISTING OF HORN GAPS, CHOKE COILS AND WATER-FLOW GROUNTERS (OERLIKON CO.), VANDOISE MOTOR POWER CO., SWITZERLAND.

penstock, while in other plants and substations it is supplied by a centrifugal pump to an elevated tank, from

which it flows by gravity, or from city mains, or from springs when available. Fig. 14 shows a battery of



Fig. 13.—SIEMENS-SCHUCKERT HORN GAPS, WITH CHOKE COILS, HEIM 35,000-VOLT PLANT, GERMANY.



Fig. 15.—50,000-VOLT WATER-FLOW GROUNTERS AT THE STEP-UP STATION, PIATTAMALA, ITALY.



Fig. 16.—BROWN, BOVERI MULTIGAP LIGHTNING ARRESTER CONNECTED TO WATER RHEOSTAT, LOFUTCH PLANT, SWITZERLAND.

lightning arresters as installed in the hydro-electric plant of the Vandoise Motor Power Co., Switzerland. It will be observed that the connections from the choke coils are attached to the funnel through which the water flows. The upper and lower tanks are connected by piping, so that there is a continuous circulation of water.

A grounder with the stream flowing upward against a baffle-plate is seen in Fig. 15. It was installed by the Alioth Co. in the 50,000-volt substation at Piattamala, Italy. The stream of water is  $\frac{3}{8}$  in. in diameter, 28 in. high, and allows a leakage of 0.1 ampere. The water is supplied by a spring under a head of 26 ft. Ammeters are inserted in the line connection to the apparatus, to detect failure in grounding.

In transmission line construction, European engineers are frequently handicapped by public service commissions, specifying the length of spans in street and railroad crossings, and that special structures or poles have to be put up for suspending

guard wires, etc. With Heimbach 35,000-volt transmission system, Germany, much expenditure was incurred in this respect. In some crossings the public service commission was not satisfied with guard wire netting, but separate latticed steel construction had to be erected.

A good example of public service

having this expensive structure, the towers had to have a close spacing.

A novel arrangement of carrying transmission towers above the water will be found on the 27,000-volt Obermatt-Lucerne line, Fig. 19. Owing to the depth of the lake, the narrow street and the steep mountain on the other side, the only solution for placing the



Fig. 17.—50,000-VOLT TRANSMISSION LINE, KYKKELERUD TO HAFSLUND, NORWAY.

regulation in transmission line construction is shown in Fig. 17, giving a section of the 50,000-volt line between Kykkelerud and Hafslund, Norway. The close spacing of the towers was not alone sufficient; triangular steel frames had to be attached to the cross-arms so that in case of the breaking of a conductor the line is instantly grounded. A lat-

towers was on cantilever structures held in position by heavy concrete blocks. In order to protect the cantilever and the tower itself from boulders, heavy masonry abutments were placed on top of the concrete blocks; a passageway is provided to reach the tower. The total length of the cantilever is 30 ft., and the spacing of same 400 ft. The towers them-

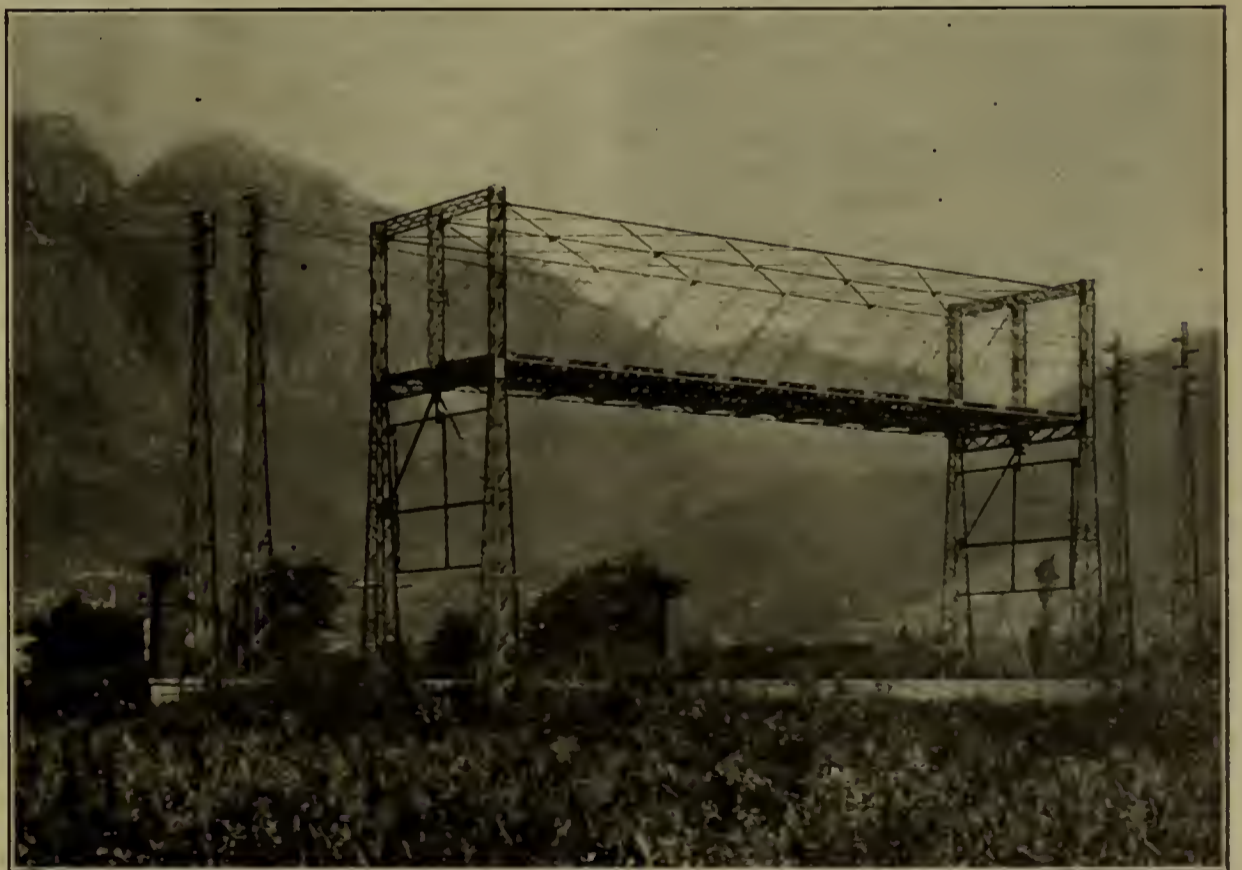

Fig. 18.—RAILWAY CROSSING OF 50,000 VOLTS, BRUSIO, SWISS-ITALIAN TRANSMISSION SYSTEM.

ticed structure used on the 50,000-volt Swiss-Italian transmission system (Brusio) is seen in Fig. 18. Besides

selves are about 45 ft. high, measured from the cantilever to the lowest conductor. It will be observed, a



Fig. 19.—27,000-VOLT TRANSMISSION TOWER, OBERMATT-LUCERNE, SWITZERLAND.

practice common in continental line construction, that angle iron guards are placed to prevent a wire from falling to the ground in case of the breaking of an insulator, etc.

One of the latest and foremost transmission systems in Europe is in the northern part of Italy, receiving its current from the hydraulic plant at Campocologno, located in the utmost southeastern part of Switzerland. The generator voltage (7000) is sent across the boundary through a tunnel, 1650 ft. long, to a substation at Piattamala, where it is stepped up to 50,000 volts. This tunnel is eight to 10 ft. wide and 9.8 ft. high, the top being arched. Two separate circuits are placed, one on either side of the tunnel, and are provided with a removable guard netting.

The tunnel scheme was chosen because the narrow valley through and over which the line would have to pass is frequented by storms, atmospheric discharges and great temperature differences.

The substation at Piattamala is built in the shape of a "T," accommodating 24 oil-cooled water-circulated transformers, 1250 kw. each. The transformers are arranged in two rows, between which are transfer tables for removing transformers to the repair room at the end of the crossleg of the "T." The 7000-volt leads enter the substation at the bottom of the "T," and leave same at both ends of the crossleg.

The transmission line is in duplicate spaced from 13 to 16.5 ft. apart. The towers of latticed construction are about 40 ft. high up to the lowest conductor, and the average spacing is 393 ft. while the longest is 1280 ft.,

crossing the Gravina Valley at Colico. The lowest point of the transmission line is 640 ft. above sea level, crossing the Adda Valley; the highest point is at Palasco, 2130 ft. above sea level. The whole 50,000-volt transmission is 83.5 miles long.

From Lomasso, where the step-down station is located, a 20,000-volt line runs to Como, a distance of 30 miles, while a 11,000-volt line runs 85 miles southward to a steam plant at Castellanza, for giving or drawing current from same. The bulk of the

small design; they are made either of one or two pieces.

Fig. 21 shows a four-petticoat, two-piece insulator much used in Swiss and Italian practice, which is the result of many years' experience. The insulator shown has been used on a 50,000-volt Italian transmission line. It is 12 in. high and about 13 in. in diameter.

Particularly on the continent, insulators are frequently fastened to their pins by hemp and tow, with shellac or asphalt. Cement is not



Fig. 20.—HIGHWAY AND TELEPHONE CROSSING OF 50,000-VOLT LINE NEAR LECCO, ITALY, ALSO SECTION SWITCH-HOUSE.

current goes to weaving mills.

The whole transmission line is divided into sections, varying from 8.5 to 25.5 miles in length. At the division points the line runs through section houses as seen in Fig. 20. The latter are equipped with sectionalizing switches, measuring apparatus and lightning arresters of the horn type, provided with choke coils and water-flow grounders. As the line is in duplicate, disabled sections can be bypassed at these section stations. At a distance of 65 ft. and parallel to the 50,000-volt line is a telephone and telegraph line for the exclusive use of the company.

Contrary to the average American practice, the wall outlets are of a very simple design. They consist of one or two sheets of plate glass with a porcelain bushing, though sometimes the latter is omitted. Insulators are placed on both sides of the panel so that this section of the conductor always remains straight. In some cases porcelain bushings are inserted in the wall, and the conductors lead directly to a distant tower. The hood common to American practice is practically unknown.

Insulators on European transmission lines are of an exceptionally



Fig. 21.

very much used, owing to the expansion of the cement cracking the insulators. For the same reason two-piece insulators are frequently fastened together by hemp and shellac. Another binding material used is plaster of Paris.



# Tensile Strength of Trolley Wires

By J. E. FRIES

Associate A. I. E. E.

IT is well known that ordinary hard-drawn copper of the kind generally used as overhead conductor for trolley lines should be strung with a tension not to exceed 12 kg. per sq. mm., if permanent elongations are to be avoided. On the other hand, a certain stiffness is required to obtain a satisfactory collection of current with an average pressure from 2 up to 8 kg. between the trolley wheel and the wire. Therefore, the tension in the latter must not fall below a certain lower limit, which is the same whether the suspension is of the catenary or of the simple kind with poles 20 to 40 m. apart. This lower limit is about 4 kg. per sq. mm. With these extreme values given, it is easy to calculate the corresponding harmless variation in temperature from the known formula:

$$(t-t^1)\tau = \frac{P_t - P_{t^1}}{E} + \frac{w^2 l^2}{24} \left( \frac{1}{P_t^2} - \frac{1}{P_{t^1}^2} \right)$$

where  $t$  and  $t^1$  are the highest and the lowest temperatures in centigrades;  $P_t$  and  $P_{t^1}$  the corresponding stresses in kilogramme per square millimetres;  $\tau$  the coefficient of expansion;  $E$  the modulus of elasticity;  $w$  the weight of the wire in kilogramme per cubic millimetre and  $l$  the span in metres.

The following table gives the constants for such metals as might be used, and the figure below shows the corresponding curves where the abscissas represent span in metre and the ordinates temperature variations in centigrades:

Curve	Material.	E	$\tau$	w	$P_t$	$P_{t^1}$
I	Harddrawn Copper.....	13000	0.000017	0.0090	12	4
II	Brass.....	10000	19	86	13	4
III	Bronze.....	15000	18	87	17	4
IV	Aluminum.....	7000	23	27	10	1.2
V	Steel.....	21000	11	08	20	4

The longer the span, the greater, naturally, the harmless variation in temperature. As the span cannot very well exceed 35 to 40 m. without an excessive sag of the wire, we see that the highest allowable variation in temperature is about 50 deg. C., if copper is used. With catenary construction and suspension 3 to 10 m. apart, the curve shows a latitude of 37 deg. as the limit of variation possible, if the wire is not to be overstrained at lowest and too slack at highest temperatures. As soon as a wire becomes sooty it is rapidly heated in sunlight. Even the daily variations

in temperature will then be considerable. It is difficult, therefore, even with frequent adjustments of the wire to keep the tension within suitable limits, and this is especially the case where catenary suspension is used. The only really satisfactory remedy seems to be the employment of automatic devices for keeping the tension constant. I am told that copper wire now is brought in the market that al-

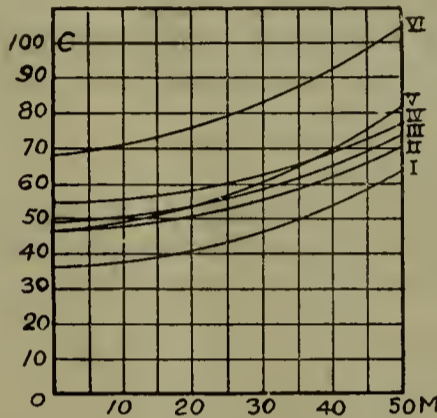

lows stresses up to 18 and 20 kg. per sq. mm. before the elastic limit is reached. Unfortunately, no information as to its modulus of elasticity is available at present, and it is, therefore, difficult to draw conclusions in regard to its behavior. It is probable, however, that it would closely correspond to curve III given for bronze wire. This, of course, would mean a considerable improvement, but not to such a degree as to obviate the necessity of readjustment from time to time were automatic stretchers are not employed.

In practice, conditions are a little

more favorable on account of the elasticity of the poles. Because of curves in the road and the zigzag suspension of the wire from pole to pole, this elasticity allows somewhat greater variations of temperature. For example, a line with 30 m. span and 20 cm. deviation from the true center of the track at each pole would stand an increase of temperature variation of:

$$\frac{\sqrt{1 + \left(\frac{0.2}{15}\right)^2} - \sqrt{1 + \left(\frac{0.16}{15}\right)^2}}{0.000017} = 2 \text{ deg.},$$

assuming that each pole yields 4 cm. at the top. To obtain an idea of the

influence of curves, we will assume that 10-deg. curves with 500 m. radius follow each other incessantly, making the road S-shaped. With a maximum bending of the poles of 5 cm. in this case, the wire could be stretched  $2 \times 0.05 \times \text{Sine } 2 \text{ deg. } 30 \text{ ft.} = 0.00436 \text{ m. per curve.}$  As the length

of each curve is  $\frac{10}{360} \pi 1000 = 87.3 \text{ m.},$  the increase in allowable temperature variation would amount to:

$$\frac{87.3 \times 0.000017}{0.00436} = 2.9 \text{ deg.}$$

Both these factors, therefore, only slightly improve the conditions. And yet the assumptions made were abnormally favorable. It is worth noting in this connection that even in the cities, where the curves mostly are much sharper, the wires often are strained beyond their elastic limit in winter-time, and, therefore, require restretching in the spring. The tensile strength and life of such wires become, of course, by and by considerably lessened.

It is further apparent from our curves that somewhat better results might be obtained with other materials, such as brass, bronze, aluminum or steel. The rapid wear, the burning and the electrolytic phenomena incident to aluminum naturally prevents the use of this metal for the present purpose, and evidently none of the other metal materials, except steel, can be expected to give a much better service than copper, even if other qualities were at par. But the stiffness of steel wire would make the stringing of same very difficult. In addition, of course, all these metals possess a conductivity inferior to that of copper.

It seems necessary then to employ some kind of automatic regulator of the tension in trolley wires, and the question arises: should springs or weights be used for the purpose? The spring volume required is calculated (as shown in Hutte's "German Engineering Pocket Book") from the formula:  $V = 0.136 L,$  where  $V$  is the volume and  $L$  is the work of the spring in centimetre kilogrammes, for it is evident that the volume must stand in an approximately constant ratio to the work represented by the elastic deformation, and this ratio varies for different materials, being about 0.136 for spring steel, according to Hutte. At a temperature variation of 100 deg. the ex-

pansion of the wire amounts to 170 cm. per km. less the extension of the material, due to the stretching tension. We may, of course, when using automatic stretching devices demand that the tension in the wire remains fairly constant and of a value that best favors the current collection. If, for instance, the section of the wire is 65 sq. mm. and we allow the tension to vary between 500 and 600 kg., then the elongation per kilometre is 11,8 cm., with a modulus of elasticity of 13,000 kg. per sq. mm., and, therefore, the total work of the spring:

$$L = \frac{1}{2} \frac{(170 - 11.8)600}{600 - 500} = 285,000 \text{ [cm. kg.]}$$

Hence:  $V = 38,700$  cu. cm., corresponding to a weight of the spring of 300 kg. per km. trolley wire. It is evident, therefore, that just as satisfactory regulation of the tension in the wire might be obtained with less cost by simply using weights, and that there is no good argument in favor of using springs for this purpose.

It has previously been assumed that the allowable tensile strain, due to low temperature or stretching weights, may amount to 12 kg. per sq. mm. This, however, is not entirely correct, as consideration also must be given to the stresses caused by the bending of the wire.

These stresses at points of support or contact with the trolley wheel may, with good approximation, be calculated as follows: If the wire had no stiffness, the angle  $\beta$  it would make with the horizon would be given

$$\text{by the expression } \tan \beta = \frac{lw}{2p}$$

where  $l$  is the span,  $w$  the weight of the wire per cubic centimetre and  $p$  the tension in the wire per square millimetre.

On account of the stiffness, however, this angle does not occur exactly at the points of support, but at a short distance therefrom in the inflection points of the wire. Instead of the span, therefore, the distance between two adjacent points of inflection should be substituted. But the ratio between this distance and the span is so nearly unity that the latter may be used with sufficient accuracy. In points of inflection the moment of flexure evidently equals zero. In the direction of the wire acts here a force  $pa$ , where  $a$  is the cross section of the wire in square millimetres. To determine the shape of the curve between point of inflection and point of support, we choose the former as origin, the direction of the wire in that point as  $x$ -axis and call the deviation of the wire at a point  $x$  for  $y$ . The moment of flexure in the point  $x$  is:  $M = pa y$ ; and the curvature at the same

point is determined by the differential equation:  $\frac{d^2 y}{dx^2} = \frac{M_x}{EJ}$ , where  $E$  is the

modulus of elasticity and  $J$  the moment of inertia of the cross section of the wire.

Substituting the value of  $M_x$  and integrating, observing that  $\frac{dy}{dx} = 0$

at  $x = 0$ , and  $x = 0$  at  $y = 0$ , we

$$\text{obtain: } y = r \left( \frac{e^{cx} - e^{-cx}}{c} \right), \text{ where } c = \sqrt{\frac{Pa}{EJ}}$$

and  $r$  is a constant which we need not define in this connection.

The maximum strain evidently occurs at the suspension point; in this

$$\text{point is: } \frac{dy}{dx} = \tan \beta.$$

For larger values of  $x$ , we may, with good approximation, put  $y = re^{cx}$ , hence at point of suspension:

$$\tan \beta = \frac{dy}{dx} = cy_0 \therefore y_0 = \frac{\tan \beta}{c}$$

Therefore, the moment of flexure at point of suspension becomes:

$$M_0 = pa y_0 = \frac{p a l w}{2 p c} = \frac{a l w}{2 \sqrt{\frac{Pa}{EJ}}}$$

for round wire is:

$$a = \frac{\pi d^2}{4} \text{ and } J = \frac{\pi d^4}{64}$$

If we now put  $E = 13,000$  and  $w = 0,009$ , we obtain the maximum stress  $\sigma$  in kg. per sq. mm. at point

$$\text{of suspension: } \sigma = 1.026 \frac{l}{\sqrt{p}}, \text{ where}$$

$l$  is the span, is expressed in metres, and  $p$  is the tension, in kilogrammes per square millimetre.

This simple equation compares very favorably for spans of over 10 metres with the much more complicated formulas generally given, but gives somewhat too high values for shorter spans.

In a 30-metre span with a stretching tension of 4 kg. per sq. mm. the maximum bending stress is consequently:

$$\sigma = 15.4 \text{ kg. per sq. mm. and with } p \text{ equal to } 12:$$

$$\sigma = 8.9 \text{ kg. per sq. mm.}$$

To arrive at the total stresses in the wire, the two strains should, of course, be added, and we obtain then 19,4 and 20,9 kg., respectively, in the two cases. It is evident, therefore, that the elastic limit of the wire is overreached at the points of suspension, so that the wire here is permanently bent. Even if the tension were kept constant at 8 kg. per sq. mm. by means of automatic stretching devices, a

maximum stress of 18,9 kg. per sq. mm. would occur, so that a permanent distortion of the wire is inevitable at 30-m. span.

When the wire is further loaded by snow and wind pressure  $\sigma$  is, of course, increased in proportion to the combined load.

Also the pressure of the trolley pole causes bending stresses in the wire. It is evident that the formula given above may be used in this case,

$$\text{if the span } l \text{ is substituted by } \frac{B}{a w}$$

where  $B$  is the pressure of the trolley wheel in kilogramme and  $a$  and  $w$  have the same meaning as before. Thus the maximum strain of flexure due to the trolley pole is:

$$\sigma = 1.026 \frac{B}{a w \sqrt{p}} = 114 \frac{B}{a \sqrt{p}}$$

Assuming now again that the stretching tension in the wire is 8 kg. per sq. mm., that the cross section is 65 sq. mm. and the elastic limit 12 kg. per sq. mm., we see that the trolley pressure must not exceed 12,45 kg., if permanent deformations of the wire are not to set in. Through such permanent deformations, however, caused by the passage of the first trolley wheel, elastic stresses are introduced in the wire which increase the normal strain in the wire at rest, but decrease the maximum strains at the following passages of the trolley. For this reason experience shows that about twice the calculated trolley pressure may be used without raising the maximum running stresses above 12 kg. per sq. mm. From these considerations it is evident that the normal stretching tension in the wire must be kept considerably below 12 kg. per sq. mm.

At points of suspension we have possibly another source of abnormal stresses in the depression of the trolley pole that takes place when the wheel commences the new span. At high speeds this motion almost takes the form of an impact. To diminish all extra stresses at these points, Mr. Jos. Mayer, of New York, proposes the use of extra long suspensor clamps. One might also employ two clamps at each suspension, or one main and two auxiliary ones, so as to give the wire a proper curvature. It has been found by experiments, however, that satisfactory current collection at high speeds may be obtained by using two trolley poles as far apart as possible, so that one is touching the wire while the other passes free or with very light pressure under a suspension point. In such case, the extra stresses at the clamps are, of course, almost eliminated.

# Suburban Electric Railway Return Circuits

By E. G. Hindert

Late Electrical Engineer, Cleveland, Southwestern & Columbus Railway

IN the early days of electric railroad-ing the return circuits were considered to be of minor importance. In some cases copper returns were laid between the rails and joined to the track at frequent intervals, but with heavier cars and longer circuits, the cost of this became prohibitive, especially when the large carrying capacity of the rails was considered.

The track joints were electrically connected with pieces of trolley wire riveted into holes drilled in the rails at each end of the fish plate. This work was left to the track department, which usually assigned it to the cheapest paid workman on the road. They did as they were told, and as near as they were capable of knowing how. Mechanically, they did a good job, but electrically it was of very short life.

I have known of cases where compressed bonds were used that the hole was too large. The hole was drilled with the use of oil, and also was left to rust before the bond was put in. In two years the cars could not make their running time. Such cases as this were referred to the power department with the query, "What is the matter with the power?" It was usually hard for the power department to convince the manager that the cause was in the track and not in the power-house. Soon automatic voltage regulators, and even voltage recorders, were installed on some roads, and thus the source of losses were practically located.

It would be very interesting if we could follow an atom of electricity on its way from the car to the power-house. At times it will go for miles away from the shortest course and perhaps come back over a rival road as far as it can, and then take to the woods, river and earth for the rest of the distance. I have known water piping to return 20 per cent., and a new concrete pipe line 2000 ft. long, 5 per cent. of the total current. The longer the route taken by the atom of electricity, the higher the cost of power to run the car.

## THE IMPORTANCE OF GOOD CONTACT

The track return efficiency depends entirely on how well the electric bonds are put on, and how tight the splice bars are kept, and this again depends upon the quality of the road bed.

The protected type of bond is the

one in more general use. There are two different styles: the compressed terminal type and the pin terminal type.

Bonds should be very flexible, easy to attach and not liable to deterioration. The terminal should be made of one piece, that is, have no soldered or brazed joints between body and terminal. Bonds should be flexible enough so that relative movement of the rail will not damage either the bond or the contact between the bonds and rail. Bonds with welded terminals are most liable to break where the flexible shank joins the terminal. Bonds should be examined carefully to detect by etching with acid.

The process of casting terminals to the ends of wire bonds has been developed until good, reliable results and practically perfect joints between the terminal and body of the bond are obtained.

The greater part of the resistance of the bond lies in the contact with the rail. If the resistivity of the steel be taken as eight times that of copper and the entire surface of the hole in the rail into which the bond terminal is expanded is assumed to be in intimate contact with the copper, the area of this surface should be eight times the cross section of the bond in order not to increase the resistance. It is impossible to secure ideal contact, and corrosion occurs which will rapidly reduce the effective area; so it is desirable to get as large a contact as possible. In the ordinary tee rails it is possible to get only ten times the area of 350,000 c.m. bonds with a practical diameter of terminals. On soldered and brazed bonds I have found that contact is often small as seen on track carrying heavy current when a light snow is falling. One end of bond may show snow melted at the terminal while the other end is all right.

In brazed bonds we find good contact over the entire bond, and as the joint is formed by pressing the copper and iron into each other in a molten condition, we obtain a contact of very enduring and high conductivity not affected by moisture and changes in temperature.

The Peltier effect is a peculiar thermo-electric property evident in an iron to copper contact. Heat is generated when the current flows from the iron to the copper, and the joint

is cooled when the current flows from the copper to the iron. This effect is so small as to be negligible, and in practice I have found the opposite ends of the bond to be the warmest, showing that it is almost entirely a matter of contact.

On soldered and brazed bonds I have found that contact is at times small, as evidenced on track carrying heavy currents when a light snow is falling. One end of the bond may show snow melted at the terminal, while the other end is covered with snow. In compressed protected bonds a poor contact shows up much more prominently, because a partial contact does not show on the surface.

In switchboard work it has been found desirable to allow 100 amperes per sq. in. of contact surface. The ordinary 0000 copper bond terminal has about  $1\frac{1}{3}$  sq. in. of contact. This limits the carrying capacity of a good bond to not over 150 amperes, or somewhat less than the carrying capacity of the copper itself. The splice bars will, if in good condition, carry from one-fifth to one-third of the total current. Therefore, under normal conditions a 0000 bond and joint should not carry over 200 amperes or 400 amperes per single track. Very frequently a single track will have three or four large cars taking an aggregate of 600 to 1000 amperes. Thus very frequently the joints will be forced to carry three times their normal capacity. This is sure to have a bad effect on the life of bonds, for we usually find that when we run any kind of machinery at such large overloads, the life of the machine is very short indeed.

We have often seen large areas of snow melted around such joints. A great many of these will melt in a day as much as 5 lbs. of water on an expenditure of 1 h.p. I do not doubt but that the average road furnishes enough power for melting snow or heating the atmosphere, which, if properly used, would enable from 10 to 20 per cent. more cars to be operated.

I have often noticed that the first car in the morning had poor power, whereas the second could make running time easily. I attribute this to moisture creeping in on poor joints and oxidizing the contacts. The vibrations of the first car were enough

to wear some of the oxidation off of the joint and rail, so that the next car had less resistance in the return circuit.

Of the defects in bonding the most important is oxidation. This is hastened by moisture. The slightest crevice is dangerous to the life of the bond. Soft soldered contacts underground in wet streets are not to be trusted; though above ground they should be durable.

Brazed joints seem to be free from trouble. Amalgamated steel surfaces are not durable and soon rust.

#### TYPES OF BONDS

The brazed bonds are light and hard to remove and have therefore little temptation for thieves. If desired they can be painted with a mixture of oil, lamp black and shellac to decrease their market value as scrap. The bond has more flexibility and is lighter than the solder type of bond. It can be bought and put on for 25 per cent. less money.

Expanded or compressed terminal bonds which have not been properly applied may be loosened by the movement of the rails.

Poor bonds are often traceable to poor work in applying, due to cheap workmen and non-inspection. It is soon covered up and gets no attention until trouble develops.

Compressed bonds do not ordinarily have enough pressure applied: doubling the pressure has very materially increased their carrying capacity. Holes should be drilled with soda water lubrication instead of oil.

I do not believe any copper terminal expanded into iron will remain perfect very long, because the copper expanding more than iron with daily changes in temperature will generally loosen the bond in the hole enough so that moisture can creep in and oxidize the contact surfaces.

A compressed type of bond is now made in which several holes are drilled into the side of the ball of the rail on each side of the joint. The hole is drilled about  $\frac{1}{2}$  in. deep and slightly enlarged near bottom. The bond is made similar to the soldered type except it has round projections on the side which fit into the holes and are driven in and upset with a heavy hammer. This bond has been adopted by the Baltimore & Annapolis line. I would not consider this type as efficient as the compressed type. Bonds of a similar type to those above have been applied to the base of the rail and compressed. Before applying the bond the hole and terminal were tinned. After the bond was compressed it was soldered. Upon examination it was found that the area of solder contact was very small.

The compressed type of bond requires a more or less bulky compressor, but on the whole, protected type of bonds require but few tools. It is impossible to compress a substance into another having different ratios of expansion that will not in time open up sufficiently to allow moisture to enter and oxidize the surface and soon cause poor contact.

The protected type of bonds are expensive to replace because the splice bars have to be removed and perhaps all new bolts put on.

The soldered bond consists of a bundle of ribbon copper held together with a copper clip and in several cases these ends are flattened to give thinner contact surface and at the same time small weight of copper to avoid defective results of expansion and contraction. A stiff bond with a heavy copper terminal soldered to a rail having a different rate of expansion soon breaks the solder loose because the bond lacks flexibility.

In the East where heavy bonds have been soldered to track over which there is heavy traffic, there was soon trouble with loose bonds. Within a year they had to discard solder bonds and put on bonds of the compressed type. On the other hand the solder bond held fairly well on the third rail, showing that the working of the joints with heavy bonds caused the solder to break loose because it was weaker evidently than the flexibility of the copper.

The high heat capacity of rails makes it very difficult to get good and uniform results on the solder type of bonds.

The brazed bond has been in use several years and has demonstrated its value. The only trouble that may be experienced occurs if the copper is heated too high on fast work. It becomes crystallized and soon breaks off at the shank. This same trouble may be experienced with any welded or forged terminal type of bond.

On our road, where properly applied on good rail joints, it has given good results. This process has now been developed until it is the easiest, quickest, cheapest, and most reliable bond now on the market. The disadvantage lies in the equipment required to put it on. This has been developed until it can be handled with ease and dexterity. It can be removed from the track easily or it can run with its own power as fast as 40 miles per hr. if desired. In addition to the brazing outfit the car carries a copper welding equipment.

#### SOME NOTES ON THE TESTING OF BONDS

In making tests I found currents going directly opposite from the

source of power with no apparent connection in that direction to the return current. I therefore made measurements in order to locate the high resistance points. I measured each joint. I tried several instruments side by side; one built on the principle of a millivoltmeter gave deflection of one space for about one-half foot variation in rail length with about 500 amperes flowing in the rail. I then stepped to another rail with about 75 amperes flowing through it, and found that it required four feet of rail to give the same deflection. With plenty of current in the rail this instrument worked very accurately. The bond tester I adopted is built on the telephone receiver principle and has proven very satisfactory in every way.

In the fall of 1902 we tested nearly all of our bonds and also some on other roads in order to choose better bonds for our work. The Oberlin-Wellington division bonded with figure 8 Crown plug bonds three years old, averaged 25 per cent. bad. In the summer of 1907 this was entirely re-bonded with brazed bonds. The Elyria-Grafton division had figure 8 pin bonds two years old; 31 per cent. were bad. In 1905 one rail of this division was equipped with soldered bonds. The Oberlin-Norwalk division was on one year and tested out all

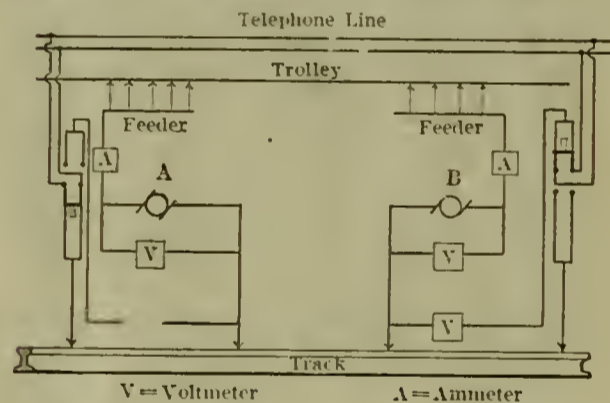

Fig. 1.—DIAGRAM OF TRACK-MEASURING CONNECTIONS.

right; in 1907, 12 per cent. were bad. The Elyria-Cleveland division figure 8 Crown plug bonds on five years, in 1902 had 75 per cent. bad; this division was in 1903 equipped with soldered bonds. On several inspections in 1903, from one to six per cent. were off.

We tested some soldered bonds at Terre Haute, Ind., on one year and found them all right. At Brazil, Ind., soldered bonds on two years tested all right. Switches, etc., had figure 8 bonds which did not test very well.

The Lorain-Elyria division of the Lake Shore Electric used the Webber joint and had nine per cent. bad.

We found that the soldered bond, though it gives excellent service electrically is mechanically weak. The bonds must be very carefully soldered in order to give any reasonable re-

sults. One section equipped in 1903 and no repairs made, in four years had 56 per cent. off, while one section on one year only had one per cent. off, and another had three per cent. off. In some instances wagons in crossing the track will cut the bonds off, and also cars with defective brake rigging have knocked off a great many of them. Much depends upon how well they are put on, but at best it is not reliable, that is, for bonds soldered to the ball of the rail. One section of brazed bonds on 14 months had one per cent. broken due to joint vibration and only one that had come off.

I measured track resistance between substations by the fall of potential method. I immediately found that it was difficult to make theory and practice agree. Invariably I found the calculated resistance more than the measured resistance. I made all possible allowances for divided circuits and found the track with very poor bonding usually tested very well.

In order to locate losses in the entire transmission system, I also measured the ohmic losses between the different substations and power-houses by the fall of potential method. I measured the amperes in the feeder and return circuits and by using the telephone wires as a volt wire, I obtained the voltage drop over the track return circuit. This method was described by me in *Electric Traction Weekly*, issue of March 19, 1908. The accompanying diagram, Fig. 1, explains the operation.

When ready to take readings, substation "A" operator takes armature leads off of the rotary commutator, bolts the ends together and reverses the shunt leads of the direct-current ammeter. The operator would then close all the switches and circuit breakers connecting "A" to "B" and then throw the telephone switch down to the ground-side.

The rotary at substation "B" would be running the same as usual, except that only the feeder switch toward substation "A" would be closed, all others being open. Substation "B" operator throws telephone switch up to voltmeter side. Substation "B" reads track volts, rotary line volts and amperes; substation "A" reads amperes. The whole operation is very simple and is done in a few minutes after the cars are all off of the line. The men soon become expert and obtain uniform results.

Authorities varied as to the proper ratio of resistance between steel rail and copper. Roughly the higher the percentage of carbon and manganese the higher the resistance, but in order to have a rail that wears well, Mr. Cole, in the *Street Railway Journal*,

Sept. 3, 1904, advised the following proportions for a rail which in straight track he estimated should last 40 years:

Carbon	.55 to .58
Silicon	.10 or under
Phosphorus	.08 " "
Sulphur	.06 " "
Manganese	.83 " "

The ratio of conductivity between rails and copper is usually taken at 10 or 11 to one.

I measured up two lengths of 70 lb. rail and found that one of them gave a resistance of 0.0000145 ohms per ft. while the other had 0.0000139 ohms per ft., a difference of four per cent. This gave a resistance of 0.0366 ohms per mile, not considering the joint resistance. The joints increased the re-

In February, 1907, I made numerous tests of the track return between



Fig. 2.—MAP OF CLEVELAND, SOUTHWESTERN & COLUMBUS RAILWAY.

Wellington and Elyria, on the Cleveland, Southwestern & Columbus Rail-

	DISTANCE Miles	FEEDER LOSSES		TRACK LOSSES	
		Measured Ohms	Calculated Ohms	Measured Ohms	Calculated Ohms
Wellington to Elyria Power House.....	15	1.99	1.782	.325	.69
Wellington to Elyria, dry and cold.....	15	2.02	.....	.409	.....
Wellington to Elyria, raining.....	15	1.95	.....	.147	.....
One mile from Wellington to Elyria Power House.....	14	1.35	1.334	.49	.644
Pittsfield to Elyria Power House.....	10.25	.87	.784	.4302	.4715
Russia to Elyria Power House.....	6	.522	.445	.4406	.276
Lorain to Elyria Power House.....	10.5	1.16	1.11	.85	.483

sistances to 0.0402 ohms per mile, or a ratio of 12 to one. The joint without bond but splice bar, rusty and bolted tight had a resistance of 0.000108 ohms. One 300,000 c.m. soldered bond reduced the resistance to 0.000065 ohms and two 300,000 c.m. bonds reduced it to 0.000045 ohms. The measurements of the joint included 27 in. of rail.

The next day I again measured the joint and found the resistance to be 0.0000657 ohms. I removed the splice bars and found the resistance to be 0.000066. I removed the bonds and found that owing to the difficulty of

way. The above table shows the results.

The bonding between Wellington and Oberlin was very bad. One rail between Oberlin and Elyria power-house was very bad and the other had soldered bonds in fair condition. The accompanying chart, Fig. 2, showing the geographical location of the points, will, in a measure, explain why the measured and calculated resistances did not agree as apparently the nearer the power-house the higher the measured track resistance.

Results show very much better conductivity during rainy weather. Dur-

	MILES	TRACK LOSSES			TRACK AND FEEDER LOSSES	
		Calculated ohms	1906	1907	1906	1907
			ohms	ohms	ohms	ohms
Elyria to Wellington.....	14.97	.699	.348	.20	2288	1.4
Elyria to Rockport.....	18.5	.848	0.	0.	1.76	1.74
Rockport to Brunswick.....	15.9	.731	.25	.23	2.78	2.66
Brunswick to Chippewa Lake.....	12.50	.575	.365	.29	2.03	1.93
Chippewa Lake to Madisonburg.....	14.65	.674	.74	.44	3.0	2.8
Birmingham to Norwalk.....	16.25	.65	.29	.25	3.0	2.96
Elyria to Birmingham.....	13.74	.55	.284	.324	2.	2.4

applying two adjacent solder bonds that I only had a total contact surface equal to what one bond should have. Oxidation had taken place and raised the bond joint resistance to an equivalent of what one bond was the day before. On the same basis a 60 lb. rail has a resistance of 0.046 ohms per mile.

ing the 10 nights readings were taken at Wellington, the lowest resistance was 0.147 for track on wet nights, and vary from 0.393 to 0.409 on dry cold nights when the temperature ranged from 10° to 26° F. In May, 1907, I opened the rail of the steam road track near the power-house and inserted an ammeter which had been

calibrated with the one on the switchboard supplying the Wellington division and found to read the same. During five minutes the switchboard ammeter averaged 151 amperes, and one at the steam road averaged 155 amperes. The readings were taken every 15 sec. The maximum amperes on the steam road crossing was 240. During this time there was one car near Wellington and one car just leaving Oberlin. During 1907 the Oberlin-Wellington division was rebonded and about half of the second rail from Wellington to Oberlin was equipped with brazed bonds, the other rail had soldered bonds on it. The Wellington track readings were repeated and the track resistance had decreased to 0.20 ohm, showing the effect of the better bonding.

The track readings for the sections were as above indicated.

At the first opportunity I measured the return current in the B. & O. steam track near the power-house and found that all the current that was going out on the feeder to the Wellington division was coming back over the Big Four steam road to Grafton and from there to Elyria on the B. & O. This current at times measured as much as 240 amperes. Russia and Lorain were evidently not favored by a steam road track return, as here the track resistance was very high. Measurements on cold, dry nights showed about double the resistance of the return circuit compared with rainy weather measurements. The following are the results of tests made during each autumn of the past three years:

instrument, built on the telephone receiver principle, because of its higher sensibility, which is very important when testing between two substations with but little or no current in the rails. If there was no current I used a water rheostat with about 75 amperes flowing through it. Quite often we would find an open joint and no current in one rail, the current having passed on a crossbond to the other rail and perhaps back again at the next crossbond, if it met another bad joint.

The results obtained showed widely different efficiencies, nearly all of which indicate how well the bonds had been put on. For instance, on one division I found the hole in the rail was too large, and the copper had not been expanded enough. On another division the splice bars were of very poor design and did not properly support the joint. Also, there was not enough of space under them to take the protected bond and the splice bars clamped the play of the bond, rather than the rail. Where soldered bonds were properly put on they gave good results. Mechanically, they were weak and where the road-bed was poor the bonds soon showed a high percentage defective.

The main track at the Elyria power-house is  $\frac{1}{4}$  mile from the switchboard. The return consists of three 000 cables and one 40-lb. rail, single track. This is entirely too small. The earth at the power-house is positive and varies from 40 to 50 volts to the negative lines on a 1400-ampere load. In England, the track voltage losses are restricted, so that no section of the track shall have more than  $7\frac{1}{2}$

the track return. Poor return circuits at times severely tax the power department to supply the demand, and, consequently, the power-station runs at a poor efficiency, and at times may become so badly overloaded that it is necessary to shut off the load and raise the steam pressure to normal. This point is especially noticeable during very cold, dry weather. Rainy weather usually lightens the power-house load considerably, due to track return circuit having less resistance. The effect of poor track returns is very noticeable on the life of the rails, and this in itself should pay for the cost of keeping the bonding in good repair.

Our voltage is automatically controlled and kept constant, and yet on wet days I am asked why the power is so good. My answer is, keep the track wet and it will always be fair.

Again, on cold, dry and snowy weather the power is poor and increases the demand for power from 10 to 20 per cent., depending upon the severity of the weather. A part of this is due to poor return circuits.

Poor return circuits at times severely tax the power department to supply the demand and consequently run at a poor efficiency when this occurs.

Much-neglected points in the return circuits are the switches and railroad crossings. Switches are much abused and in every case should have double the number of bonds that the joints have. Railroad crossings receive very rough usage, and cables should be put in sufficiently large to carry all of the return current under ground without loss. Generally, I find the cables less than half as large as they should be. For instance, a 0000 copper wire, 15 ft. long, was put on a very bad crossing with an average of about 600 amperes return current. Crossbonds on suburban work are often neglected, or stolen. To guard against stealing, I have recommended putting in pieces of old rail with bonds brazed to each end. Second-hand 25 or 30-lb. rails can be bought, spiked to a tie and connected for nearly the same cost as copper crossbonds.

The life of the rail is limited by the quality of the return circuit. Perhaps many of you do not realize that your rails are wearing out faster on the bottom than on the tread, due to the electrolytic action of the return current going through the earth to the power-house. This is especially true on paved or suburban roads. A single track presents about 25,000 sq. ft. of surface per mile from which leakage may take place. The leakage is considerably increased by the presence of salts in the earth. The chlorides are most active. It is

Place	TRACK LOSSES			TRACK AND FEEDER LOSSES		
	1906	1907	1908	1906	1907	1908
	Ohms	Ohms	Ohms	Ohms	Ohms	Ohms
Rockport to Brunswick.....	.365	.29	.2	2.78	2.66	3.15
Brunswick to Chippewa Lake.....	.5	.3	.46	2.03	1.93	2.15
Chippewa Lake to Madisonburg.....	.182	.3	.475	3.0	2.8	3.0
Birmingham to Norwalk.....	.284	.182	.2	3	2.96	3.2
Elyria to Birmingham.....	.324	.324	....	2.11	2.25	2.36

During the summer of 1907, all except the bonding on Birmingham Norwalk division was repaired, which gave noticeable lower resistances. The bonding depreciated considerably during 1908, as shown by the measurements.

I tried several individual bond testers side by side. One built on the principle of a millivoltmeter gave a deflection of one division on the scale for  $\frac{1}{2}$ -ft. variation in the length of rail when about 500 amperes flowed in the rail. I then tested an adjoining rail with about 75 amperes flowing in it and found that it required about 4 ft. of rail to give the same deflection. I adopted the R. C. Conant

volts difference of potential from the earth. It would be very expensive and usually unnecessary on suburban roads to keep the voltage here at such low figures. With three of our large cars, we could expect, with track in good repair, a drop of nearly 20 volts per mile. If the return current is 700 amperes at the power-house, from one direction with a distributed load, we should expect about 125 volts difference of potential between earth and negative bus, instead of 50. This would tend to show that, roughly, the resistance of the earth absorbs 75 volts of the losses. The earth returns from 30 to 60 per cent. of the current, all depending upon the condition of

hard to estimate how much the practice of putting salt on curves and switches to melt snow and ice hastens this form of track depreciation. I have seen rails that had been in service eight or ten years with the base almost entirely eaten away while the tread was still in good condition.

Our company has just taken up some rails that had been laid about eight years, and found the base of the rail so badly corroded that they were unfit for further use. I believe that this was nearly all due to poor return circuits. The life of these rails

was reduced about 15 per cent., which goes to show that good return circuits are profitable points scarcely ever considered in life of the rails as relating to the condition of the track bonds.

I believe for open track suburban service that 60-ft. rails with continuous type of rail joints and with rails electrically joined by brazed bonds, should be used. The rails must be laid on a good and well-drained and ballasted roadbed. The company which has a road of this character, with ample feeder system, will find

that the repairs, maintenance and operation of every department will be so low and the dividends so large for the stockholder that everybody will be using the smile that won't wear off.

Every electric railway should have a track return bonding department thoroughly organized and composed of conscientious and reliable men, well equipped with instruments for testing the track and the joints and tools for putting on the bonds. They should keep systematic records of all work done. This work, unless well done, is time and money wasted.

## On Protection from Lightning

THE report of the Committee of the National Electric Light Association on protection of lightning as usual contains much of interest and value. The report of the committee last year showed a history of comparatively few losses due to lightning; two-thirds of the companies reporting having been practically free from trouble. The committee this year has asked all the members for statements on the apparatus that had been damaged by lightning confined to lightning arresters and meters.

The replies have been classed, the same as last year, under two general heads: Stations operating under 10,000 volts, and stations having transmission lines of 10,000 volts or over.

Each one of these two classes was divided into three, as follows:

A—Companies suffering no damage.

B—Companies whose losses were not serious.

C—Companies suffering more serious losses. All who had lost transformers or other expensive apparatus during 1906.

### ANALYSIS OF THE STATISTICS.

#### *Type of the Average Station Making Report:*

The standard station runs at 2300 volts, 60 cycles, three phase, though there are several two-phase plants. The single-phase plants are mostly old plants which are using the higher frequency. The average size of stations operating below 10,000 volts is 1710 k.w., and of stations of 10,000 volts and over is 4910 k.w.

It is to be remembered that two-thirds of our members did not answer our inquiries. These figures apply only to stations making answer.

#### *Freedom from Trouble:*

A much larger percentage of companies reported trouble than last year,

due to the fact that our inquiries this year asked for more definite statements of all apparatus injured. From a comparison of the reports of companies that reported for both years it was evident that there was considerably more trouble during 1906 than in 1905. Approximately half the companies reported burned out transformers or generators. The principal loss, however, is due to interruptions of service; for very frequently transformer fuses are blown without injuring the transformers.

#### *Lightning Arresters Injured:*

There has been little complaint this year of burned-out resistances. A few companies have reported large numbers of arresters burned out, one reporting over 100. Considering that every arrester that burns out may have been the means of protecting more valuable apparatus, the arrester losses are not serious.

Most of the companies have used either General Electric or Westinghouse arresters, and both types have been about equally successful. The Stanley and Garton-Daniels arresters have been used mainly by the larger companies, who have also had General Electric or Westinghouse arresters, and it is therefore not to be assumed that apparatus injured was supposed to be protected by any given type of arrester. The statistics from this report should not be used as argument for or against any make of arrester.

Very few companies have used "Horn" arresters. When used they have been installed at the power stations as an additional protection to the stations, over and above multi-gap arresters.

#### *Transformers Burned Out:*

Transformers of the small, old, air-cooled type have suffered principally. Current transformers (series transformers used with instruments or

switch gear), especially those on high-voltage lines, have burned out frequently.

Only 1.07 per cent. of the total transformers in service have been injured by lightning.

Of the companies that have reported transformer losses, one-half have lost less than 1.4 per cent. of their transformers. Some have been especially unfortunate, losing over 5 per cent. during the year.

If a company loses more than 1.5 per cent. of its transformers from lightning, it should examine carefully its system of lightning protection. It is thought that, in the present state of the art, good practice should keep the losses of transformers by lightning down to or below 1 per cent. of the number connected.

#### *Meters Burned Out:*

Direct-current meters appear to be especially weak points, for most of the meters burned out are on direct-current lines. It is especially difficult to protect these, and the meter manufacturers should provide as much protection as possible on the meters themselves. The expense of repair of meters is small, but the loss of revenue due to stopping of the meters may be considerable.

One company having approximately 2400 meters on an overhead direct-current network reports that it had been for the past two years exempt from troubles of this kind previously had, because (it so reports) of its installation of choke-coils on each service where a meter shunt was burned by lightning. The theory was that these points were natural discharge points for any surging due to lightning and that the meter shunt—the neutral wire being connected to earth—was the easiest point of discharge during daylight thunder-storms when no lamps were turned on.

The company therefore connected in each wire of the house service a choke-coil of 16 or 25 turns of No. 8 or No. 6 wire, according to the size of the service wire, the coil commonly used having an internal diameter of 12 inches and the winding being 4 or 5 turns to a layer and 4 or 5 layers, according to whether the coil was a 16-turn or a 25-turn coil. The wire used was weatherproof, and the coil was painted with asphaltum, taped with paragon tape and set on top of a glass insulator.

When these coils were installed on the service wires a pair of lightning arresters was installed on the line at the next pole to provide a discharge point for the lightning, which previously found its way through the meter shunt. This plan appears to be worth trying. It is inexpensive, and the theory seems to be correct.

#### *Generators Injured:*

There have been very few generators injured. One notable case was that of a 200-k.w., 11,000-volt generator, which burned out several times during the year. The mild storms were as dangerous to this generator as the heavy storms. This experience is similar to that reported last year with a 6600-volt, 200-k.w. generator, and shows that small high-voltage generators are especially susceptible to the high-frequency currents induced in the line by lightning.

Another notable case reported was that of a low-voltage generator, which was burned out by a high-frequency surge, caused by a short-circuit on one of the high-tension lines near the station. The insulation between wires was defective at this point, and lightning discovered this weak point and started an arc between the wires. The generator was broken down by the third lightning discharge at this point. There was no evidence of a discharge to earth when the generator broke down.

#### *The Use of Choke-Coils:*

Choke-coils are seldom used except at the generating stations, and most of the stations operating at less than 10,000 volts do not use them at all. It is evident that choke-coils in the stations protect nothing but the generators and station apparatus.

It may be of interest to note that, of the fourteen generators burned out in stations operating at less than 10,000 volts, two were protected by choke-coils and twelve were unprotected. This may have been merely an accidental coincidence. Of the eight generators burned out in stations operating at over 10,000 volts, seven were apparently protected by choke-coils. It may be noted, however, that nearly all the plants operating at over 10,000

volts used choke-coils, so that there is no argument here against the use of choke-coils.

#### *The Use of Overhead Ground Wires:*

Very little could be learned in regard to the experience of companies with overhead ground wires. Only eighteen had had experience with these during lightning seasons, and eight of these were not satisfied. The barbed wire, or small iron wire, used by these companies had broken frequently and had caused interruptions to service by grounding the high-tension lines.

All the objections made are due to the mechanical construction, and are not objections to the use of overhead ground wires of proper design.

The following experiences are of interest:

One company has operated a 16,000-volt line over twenty miles long with three barbed wires above the transmission line. During eight years no pole has been struck and no insulators have been broken. One high-tension transformer was burned out, so that the protection offered by the overhead ground wire was not absolute. The section of country through which this line runs is afflicted with very severe lightning.

Another company reports that it has two 3-phase lines on a single long-distance pole line, and it is the regular practice to cut out one of the 3-phase lines during thunder storms, and to ground all three wires at each end and in the middle of this line. No apparatus has been lost when the lines were so connected, but apparatus has been lost when both lines were in service. The engineers of the company are satisfied that this is a practical demonstration of the advantages of the overhead ground wires, and they are advocates of the use of overhead ground wires on all transmission systems.

A company that installed overhead ground wires last season has noted from test papers in the ground connections that the discharges to earth from the overhead ground wire are very frequent.

A large company that uses an overhead ground wire for connecting the secondary neutrals of most of its transformers to earth, reports that it has never lost a transformer which was connected to this overhead ground.

The grounding of transformer secondaries is well worth considering by all companies. In cities where there is much return current from the electric railways this wire should be connected solidly to earth at only one point, to prevent the ground wire from carrying part of the return railway current; but frequent

opportunities to discharge to earth through a single spark-gap should be made.

The conclusion from the above testimony is that overhead ground wires are of undoubted benefit where they are installed so as to be mechanically strong, and the question of their advisability for any company is largely a question of cost.

#### *Damage to Poles and Insulators:*

The statistics with reference to poles and insulators are very indefinite, for the length of transmission lines may be considerably more than that given in the table. Using the figures from the table the losses for the year are one pole for every 14.6 miles of pole line and one insulator for every 12 miles of pole line. If we consider only the lines operating at over 10,000 volts, the losses are one pole for every 19.2 miles of pole line and one insulator for every 13 miles of pole line.

#### PROTECTION SITUATION.

Half of the companies reporting are satisfied with their present protective apparatus. Over half of those not satisfied feel that their lines need more arresters. This leaves less than one-fourth who are altogether dissatisfied, and some of these have had no trouble resters for several years, except in mechanical construction. Many new types have been brought out, but have been discarded, and we still find the multiple-gap arrester, with non-arcing metal, the standard arrester for most of their lines.

The electrolytic arrester, which is still in the experimental stage, is awaited with hope that it may prove to be the ideal arrester, and most of the companies visited wish to try this on their lines, reasoning that it cannot do much harm and may be just what is looked for. It was learned that the electrolytic arrester has now been given one long-service test, and apparently has few troubles. A season's test on some of the lines most afflicted with lightning would furnish a convincing demonstration as to whether or not the electrolytic arrester will stand the hard knocks of regular service.

#### TRANSFORMER CONNECTIONS

Most of the transmission companies reporting are using, and prefer, oil-insulated transformers, for high voltage; for the oil-insulated transformer stands the excessive potentials of lightning much better than the air-blast transformer.

Delta connection of transformers for even the highest voltages is advised, because of the chance of carrying the load temporarily with two transformers if the third is punctured by lightning. Single-phase trans-



formers are preferred by most, for their high-potential transformers, for the same reason. There are, however, many points in favor of the 3-phase transformers for high potentials, and where used they are giving very reliable service.

The series transformers on the high-potential lines have caused much trouble, for they make most excellent choke-coils for lightning. A small air-gap should always be connected across the terminals of a high-potential series transformer.

The Washington Water Power Company has noted that after every thunder storm it has to test out the carbon resistances of its arresters with a magnet, for after a discharge many of these carbon sticks show an extremely high resistance and have to be replaced by others.

The experience of some of these companies with overhead ground wires has been noted above.

Choke-coils are used at all main stations. No two stations used choke-coils of the same design.

It is interesting to note the comparative freedom from trouble of the systems using very high voltages. Chance may have had a good deal to do with this, but this is in accordance with what might be expected theoretically. The very high voltage apparatus has to be insulated very thoroughly to protect it from normal voltage; and the potentials due to lightning are not so enormous compared to the normal voltage as is the case with low-voltage systems. The large capacity of a long-distance overhead system tends to keep the potential of high-frequency waves down below a dangerous point, for the energy of the discharge is consumed in charging the lines.

#### GENERAL CONCLUSIONS.

A certain percentage of loss due to lightning cannot be prevented. This unavoidable percentage, however, for the average company, is small.

The apparatus of the present day, except meters, is insulated so well that it will withstand very high potentials for short periods. The difference be-

tween the old transformers and the modern oil-insulated transformers is especially marked in this respect.

Lightning arresters are necessary on all circuits, and should be installed on distribution circuits wherever there is apparatus to be protected, because violent discharges prefer to jump large air-gaps rather than to travel 600 or 700 feet to the nearest arrester. The best practice calls for arresters at each transformer, and at ends of branch lines.

The multi-gap arrester still remains the standard arrester for alternating currents, but is now built with part of the gaps shunted by permanent resistance, or, in some cases, by a fuse wire.

The overhead ground wire, when tested thoroughly, has been proved to reduce losses due to lightning.

Choke-coils have a definite value, but are not to be recommended for promiscuous use. Where experience or calculation indicates their use they should be installed. Used in the wrong place they may do harm.

## Rushing a Telephone Switchboard to Paris

By C. H. CLARK

ON September 20, 1908, there occurred in Paris a fire causing a direct loss of about six million dollars' worth of property. While in itself this seems a trivial matter in comparison with calamities which have befallen other cities, yet the re-

The particular building and equipment destroyed by this fire, that of the central telephone exchange, was the one and only building in Paris the destruction of which could "paralyze her business," as the daily papers expressed it at the time.

the service. The one important problem with them now was to replace the complicated switchboard and wiring system, by means of which the thousands of subscribers' calls were handled. Aside from the fact that they must secure reliable equipment that would insure satisfactory service such as their customers had always been getting, the one idea they had in mind was speed.

It has almost become an established custom for the European to come to the American when the seemingly impossible must be accomplished. It was therefore natural, in this instance, that the problem should be put up to American ingenuity for solution.

As it happened, the largest telephone manufacturing company in the world, an American concern, had a house conveniently located in Paris, and knowing, as the telephone company did, that these manufacturers held all records and were equipped as no other company in the world was for rapid work, they naturally turned to them.

But a short time before this company had met similar emergencies on a somewhat smaller scale for the cities of Antwerp and Tokyo. Although in these cases they had made records for speed far beyond anything that had been accomplished previously, it



FRONT VIEW OF SECTION OF NEW WESTERN ELECTRIC PARIS TELEPHONE SWITCHBOARD.

sults were such that commercial Paris was placed in a more helpless condition than has been the lot of any other city in modern times, with the exception of San Francisco.

Realizing as they did the serious aspect of this situation, from the subscribers' standpoint as well as their own, the telephone company lost no time in making preparations to renew

remained for the present emergency to show their real resources.

On September 29th the order was placed and transferred to the New York house by the Paris house of this company. The New York house immediately telephoned the factory at Chicago, requesting them to begin work on the switchboard. The information received from the telephone company concerning the equipment

shipment a little over three weeks after work was begun.

In addition to the switchboard, orders were filled by the factory for 135,000 ft., or practically 25 miles of telephone cable. Although the factory had this cable in stock, it was necessary to unwind the entire 25 miles of cable from the reels, paraffine the ends, rewind it on the reels and pack it in waterproof cases to protect it



REAR VIEW OF TELEPHONE SWITCHBOARD, SHOWING FRAMEWORK.

required, was far from definite as yet, but the facts concerning delivery were more than clear; namely, that the Paris house had promised the completed equipment, ready for service, within sixty days, with a penalty of \$600.00 per day for all time over that interval.

Accordingly, the switchboard department was set to work lining up a standard board for the number of lines specified.

On October 3d definite information was received which confirmed the action of the switchboard department, and on this day the cutting and drilling of the framework parts was commenced. By October 8th the completed framework had been erected on the floor of the wiring department. The woodworking and wiring departments began work simultaneously, and on October 23d the board was ready for shipment.

While this part of the work was being pushed along in one department, in another the cabling was being prepared. On October 8th work was started with 24 men soldering 3000 connections per day. When the job was completed on October 23d, there were 65 men soldering 25,500 connections per day. The cabling on the job contained 3000 miles of single conductors.

The finished board, 180 ft. long, and requiring 90 operators to operate it, was completed and ready for

from the salt water. These operations were completed in less than two days after the order was received.

The traffic department also came in for its share of the responsibility. Immediately upon the receipt of the order, it obtained an estimate on the number of carloads and weight of the shipment. By means of a pre-arranged agreement with the railroad company, the six carloads of material were shipped from Chicago to New York in about two days. Reservation was made on one of the French line steamers sailing on October 29th, and in a month the completed switchboard was on its way across the Atlantic.

The back of this switchboard contained about a million soldered connections and 3000 ft. of wire. Approximately, 40,000 ft. of lumber was used in packing the switchboard, and 10,000 sq. ft. of paraffined paper was used in waterproofing the cabling boxes.

#### The Extension Diffuser

The extension diffuser illustrated herewith has been designed to meet the demand for an incandescent fixture embodying the aesthetic as well as the scientific principles required for high-grade lighting. It was originally designed by the General Electric Company for use on railway cars, but is especially adapted and recommended for store lighting and for installation on low ceilings.

As will be noted in the accompanying illustration, the construction of the outfit is remarkably simple; the appearance neat and pleasing. The diffuser can be easily installed on any ceiling where a small flat space can be provided, or it can be suspended from open-work construction. It is readily adapted for recessing so that the outer edge is flush with the ceiling line.

The diffuser is held in place by the suspension rods from which the shade is hung, and the heavy dull finish makes it difficult to distinguish it from plaster. The shade is of white opalescent art glass, strongly bound together, and is specially constructed for rigidity. The glass used in the shade is selected and arranged so as to give maximum diffusion with the minimum absorption of light.

At the present time the extension diffuser is made in two sizes only, the three- and six-light; both, however, being adapted for use with Tungsten, Tantalum or GEM lamps. The lower shades are made in two different styles, known as the deep and the shallow types. The shallow shades are used with lamps of sizes up to and including 40-watt Tungsten, 40-watt Tantalum and 40-watt GEM. The deep shades are necessary for use with lamps up to and including 100-watt Tungsten, 80-watt Tantalum and 125-watt GEM. Clear glass lamps only should be used as the light is thoroughly diffused by the upper and lower shades.

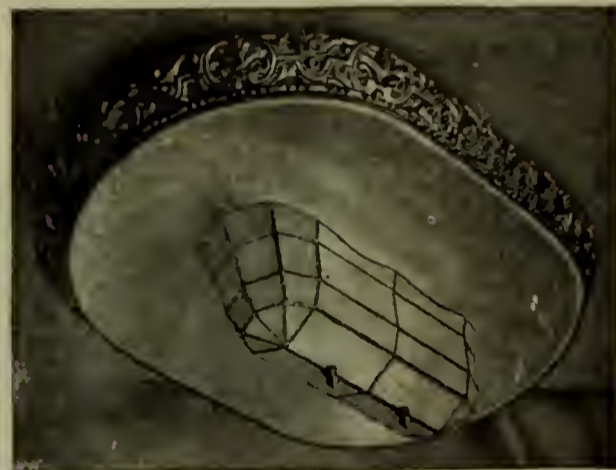

The distribution of light from the extension diffuser is not symmetrical about the vertical axis as in most lighting units. At angles approaching the horizontal, the diffuser emits more light laterally than longitudinally. This is of special advantage in stores when the equipments are installed longitudinally over the center of the aisle. The maximum light being thrown out toward the counters and stock shelves, very little light is thrown directly in the eyes of the customers. The efficiency of the extension diffuser, when compared with other lighting units, is relatively high,

especially in consideration of the excellent diffusion. Summing up of the advantages of the extension diffuser, it is of pleasing and attractive appearance, easy and economical to install and maintain; the light is of excellent quality, well diffused and powerful, the light being directed just where it is needed the most. On the whole, the extension diffuser promises to become very popular in places where an efficient and ornamental lighting unit is desired. A three-light extension diffuser was used by the General Electric Company in their exhibit at the New York Electrical Show a few weeks ago, and doubtless many will remember the pleasing appearance of the lighting unit when in operation.

#### A New Weinland Turbine Cleaner

Weinland boiler tube cleaners are now being furnished with a new type of head which promises greater efficiency than possible with the former construction. The prominent feature of this Weinland Wing-Head, as it is called, is the large number of cutter wheels swinging on crosswise arms, and so mounted that the cutting wheels attack scale simultaneously in three different sections of the tube. Each arm works entirely independent of the others, so that the general effect is that of a number of cleaners all operating at once. The forward arms are provided with conical cutter wheels in front, each of which is followed by three star cutters mounted on the same shaft. The second, or rear arms, contain three cutting stars each, and finish the cleaning operation by removing the last particles which may have escaped the forward wheels. It will thus be seen that as each pair of cutters revolve in a different path, a large surface is being cleaned at one time and, as the cleaner travels, the scale surface is successively attacked by the separate sets of cutters. Numerous tests of the new type of head prove that it works faster than the older type, and that it removes scale more thoroughly without injuring the tubes. The cone and star cutters are the only parts subject to much wear, and they may be replaced for practically nothing. The arms and pins are all hardened steel and made extra heavy, both to add strength and to give more power.

A specially compact head with universal joint is made for cleaning curved tubes, and special sizes are made for each size of straight tubes.

The Weinland ball and thrust bearing cleaners equipped with the wing-head are fully described in a new 36-page catalog, which will be sent by the Lagonda Mfg. Co., Springfield, Ohio, to those interested.

#### News Notes

Another large manufacturing plant, that of the Estey Organ Co., in Brattleboro, Vt., is to install electric drive throughout their works. This is the largest organ factory in the world. They have just placed with the Crocker-Wheeler Company, of Ampere, New Jersey, an order for 57 induction motors, ranging from  $\frac{1}{2}$  to 75 h.p., together with seven transformers and a switchboard. Current will be purchased from the Connecticut River Power Co. Some of these motors will be used for driving individual machines and others for driving line shafting. The proper subdivision of the plant into groups and individual machines was a nice problem, and was successfully worked out

manhood embodied in Crocker-Wheeler machinery were strong points, but the fact which finally determined the mill to give the order to the Crocker-Wheeler Company was the excellent showing made by the Crocker-Wheeler engineers in the previous equipment of a number of large cotton mills in the United States and Canada. The motors are 5500-volt, 60-cycle, three-phase machines, and the present order aggregates about 2500 h.p., the motors ranging from 25 to 150 h.p. each.

#### Bristol's Electric Time Recorder

Bristol's New Electric Time Recorder was designed to meet the widespread demand for a simple and practical instrument to record automat-

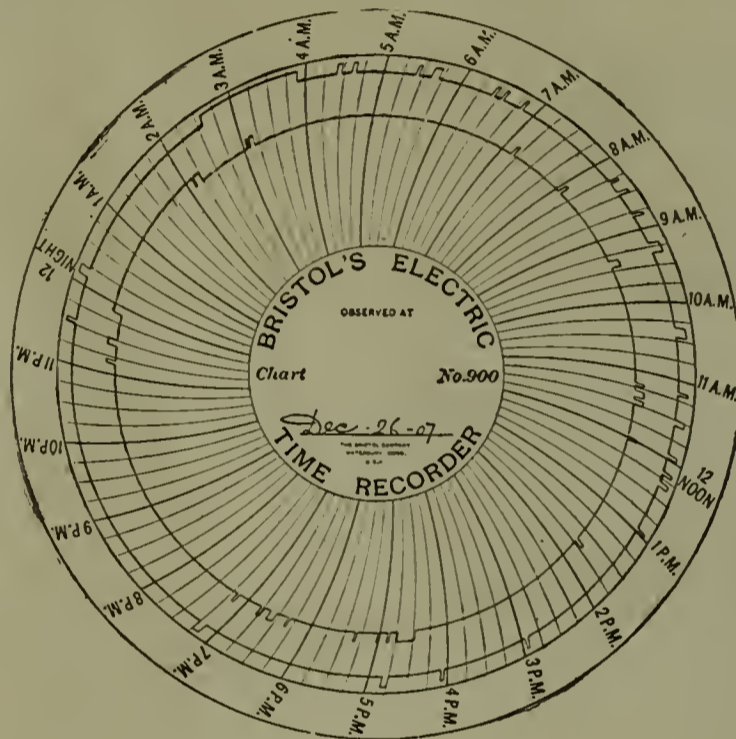

Fig. 1

by the engineers of the Crocker-Wheeler Company.

One of the most important orders recently booked in the electrical field is that for about 2500 h.p. of induction motors for the Clark Thread Company, in Newark, N. J. The order itself is of considerable size, but its chief importance is its being the beginning of the electrification of these mills, probably the most extensive cotton mill in the United States. The mill has been driven by several steam engines, and this purchase of induction motors is the first step in electric drive. The order was awarded to the Crocker-Wheeler Company, of Ampere, N. J., after a thorough investigation extending over a period of 10 months. It was thus awarded because of the thorough confidence on the part of the Clark Thread Company that the Crocker-Wheeler engineers knew how to solve the intricate electrical problems met with in textile work. The high efficiency, high-power factor, economy of operation and excellence of design and work-

ically the occurrence and duration various operations, such as the starting and stopping of machines, opening and closing of valves, duration of runs, the passing of tr etc., etc. With the instrument recorder it is possible to record several different operations on the same chart and locate the long distance from points at which such operations occur.

Fig. 1 is a reduced cut of a record chart showing complete 24-hr. record of the operation of two paper machines. This record shows the time and duration of each break, and the time required to wash the and put on new wires.

One of these recorders arranged to record operations at six different points is shown at Fig. 2. Each one of the six pens on this instrument makes an independent record, continuously and automatically, and in this way six different operations may be recorded on the same chart. Each pen-arm is actuated by an independent electro-magnet and battery-circuit, so arranged that closing the

circuit causes the pen to move a certain distance on the chart.

These recorders are usually operated by a battery circuit, but any convenient circuit may be employed by the insertion of lamps or other resistance to reduce the electromotive force across each electromagnet. The



Fig. 2

object whose motion is to be recorded is caused to make and break this circuit through any convenient contact. The Bristol Company, of Waterbury, Conn., are the manufacturers of these recorders.

#### The Chicago Electrical Show

Chicago's fourth annual electrical show is announced to open in the Coliseum Saturday afternoon, Jan. 10th, and run until Saturday night, Jan. 30th. With the show still one week away, more than 75 per cent. of the space is sold, and the list of exhibitors includes many of the leading electrical concerns of the United States and Canada. Mr. John C. ... is temporarily managing the show during the illness of Mr. Niesz.

#### Large Transformer Contract for Westinghouse Co.

Through its New York district office, the Westinghouse Electric & Manufacturing Co. has just booked an order from the Southern Power Co. for 93,000-kw. capacity of transformers, costing, all told, about \$350,000. The transformers will range in line from 1000 to 9000 kw., and will be wound for 100,000 volts. They will be used on the transmission line of the Southern Power Company between Charlotte, Greensboro and Greenville. The Company's transmission network is one of the largest in the world, and distributes approximately 200,000 horse-power.

#### New York & New Jersey Telephone Co.

Announcement was made on November 25th of an issue of \$5,047,000 additional capital stock by the N. Y. & N. J. Telephone Co. of New York. This stock is offered to stockholders at par in the proportion of one share of the new for five of the old, and the proceeds are to be used for retiring construction notes and providing further necessary additions to the construction account.

#### Mutual Telephone Co. Purchases an Additional Plant

The Mutual Telephone Co., Des Moines, Iowa, has purchased the plant and holdings of the Hawkeye Telephone Co. for \$350,000. The system thus acquired includes 5000 miles of toll lines and some 1100 miles of rural line, as well as the exchanges of a number of Iowa towns.

#### Personal

Mr. F. J. Sprague, who was some time ago appointed consulting electrical engineer for the Southern Pacific Co., is now in San Francisco.

Mr. B. H. Bendheim has been made manager of the New Orleans office of F. E. Newberry & Co., electrical engineers and contractors, and will direct all work in the Southern states.

Mr. Frederick Lake, electrical engineer in charge of the transformer house of the Niagara, St. Catherines & Toronto Railway Co. at Niagara Falls, has severed his connection with the company to take a similar position with the Cataract Power Co., at Niagara Falls.

Mr. John Mustard, until lately manager of the Eastern district office of the Wagner Electrical Manufacturing Co. at Philadelphia, has been appointed assistant manager of sales for the territory east of Pittsburgh.

Mr. Grant W. Spear, vice-president of the Dearborn Drug & Chemical Co., of Chicago, has taken charge of the New York office and will hereafter act as eastern manager, in place of Mr. W. B. McVicker, who has severed his connection with the company.

#### Trade Publications

Westinghouse Nernst Multiple Glower Lamps; 4½ by 6; 40 pages. Nernst Lamp Co., Pittsburg, Pa.

The Central Electric Co., of Chicago, are distributing a highly illustrated and interesting publication describing the manufacture of Silico-

Vanadium steel, and everyone interested in this subject should secure a copy.

General Storage Battery Co., New York, is sending an attractive booklet describing its well-known battery.

The Buckeye electric blue printing machine is the principal topic of a Picture Talk on Halos, by Prof. A. C. Tinic.

The Central Electric Co., Chicago, is distributing an illustrated 15-page circular describing its new P-M remote central switches.

The Roebing Press has just issued a book describing the ceremonies at the unveiling of the monument to the memory of John A. Roebing.

The Electric Storage Battery Co., Philadelphia, Pa., has issued a bulletin covering oil switch batteries for operating remote control switches.

Jordan Bros., Inc., 74 Beekman St., New York, have just issued a neat pamphlet telling about their well-known commutator truing device.

The Diehl Manufacturing Co., Elizabethport, N. J., has recently issued Bulletin No. 56, devoted to its sewing machine motors, for operation on direct-current circuits.

H. Krantz Manufacturing Co., of Brooklyn, has issued recently Bulletin No. 22, devoted to its punched clip knife switches, giving an engraving and full details as to sizes, prices, etc.

The American Steam Gauge & Valve Manufacturing Co., Boston, Mass., has just issued a handsome catalogue covering the various forms and types of valves and their parts, as manufactured by it.

Pipe Toplets is the theme of the November issue of "Paistery," the publication of the H. T. Paiste Co. of Philadelphia. "Toplets" is the name of a new line of conduit fittings being brought out by the Paiste Co.

The Western Electric Co. has issued a bulletin describing its Victor Flowing Arc lamps. One of the distinctive features of this lamp is the absence of any mechanism for feeding the carbons, which is done by gravity.

The Pittsburg Transformer Co. has just issued a pamphlet entitled "Making Pittsburg Transformers," in which, with the aid of the camera, each step in the manufacture of the company's product is clearly shown and all details are explained.