

MIT LIBRARIES



3 9080 02811 0192

#1

V393
.R467

NAVY DEPARTMENT
DAVID TAYLOR MODEL BASIN
WASHINGTON, D.C.

ADDITIONAL NOTES ON THE CONDITIONS OF FRACTURE
OF MEDIUM STEEL SHIP PLATES

by



D.F. Windenburg, Ph.D.,
and
Captain W.P. Roop, USN

RESTRICTED

June 1945

Report R-271

DAVID TAYLOR MODEL BASIN

Rear Admiral H.S. Howard, USN
DIRECTOR

Captain H.E. Saunders, USN
TECHNICAL DIRECTOR

HYDROMECHANICS

Comdr. E.A. Wright, USN

K.E. Schoenherr, Dr.Eng.
HEAD NAVAL ARCHITECT

AEROMECHANICS

Lt. Comdr. C.J. Wenzinger, USNR

STRUCTURAL MECHANICS

Comdr. J. Ormondroyd, USNR

D.F. Windenburg, Ph.D.
HEAD PHYSICIST

REPORTS, RECORDS, AND TRANSLATIONS

Lt. M.L. Dager, USNR

M.C. Roemer
TECHNICAL EDITOR

PERSONNEL

The tests forming the basis of this report were conducted by H.R. Thomas. The data were reduced by Miss K. Tilghman. The report was checked and reviewed by H.R. Thomas.

ADDITIONAL NOTES ON THE CONDITIONS OF FRACTURE
OF MEDIUM STEEL SHIP PLATES

ABSTRACT

A series of medium steel tensile specimens each 24 inches long, 12 inches wide, and 3/4 inch thick, with a notch at midlength and midwidth, were tested to rupture under static loading at various controlled temperatures. It was found that the degree of ductility as well as the mode of rupture was affected by the temperature. A specimen notched with a hacksaw cut broke with a cleavage fracture at a temperature of 75 degrees fahrenheit whereas a similar specimen when tested at a temperature of 100 degrees fahrenheit broke with a shear rupture. The characteristics of the breaks were not altered by the presence of sharp fatigue cracks at the ends of the sawcuts.

INTRODUCTION

Earlier accounts of the progress of thought at the David Taylor Model Basin about the plastic behavior of metals have been given in previous reports (1)* (2) (3) (4). Summarizing briefly, these stated that in many applications the capacity for elongation in shipbuilding steel is thought to be more important than its strength, and that the elongation, even in steel ordinarily quite ductile, may drop to extremely small values when the history,** geometry, and temperature of the specimen, and the speed of the load application, or rate of strain, fall within certain limits. The main purpose of continued work at the Taylor Model Basin is to find certain of these limits as they apply to the distinction between cleavage and shear modes of parting.

In the present report the following arbitrary terminology is used.† A plate is said to be brittle if the plastic reduction in thickness does not exceed 2 per cent at the fractured surface; otherwise it is said to be ductile. The break is called a cleavage fracture if the parted surfaces are perpendicular to the plane of the plate. Thus it is possible to have either a brittle or a ductile cleavage fracture depending upon the amount of plastic elongation in way of the notch prior to rupture. If the parted surfaces are inclined to the plane of the plate, the break is called a shear rupture.

* Numbers in parentheses indicate references on page 18 of this report.

** By history is meant the chemical, metallurgical, and mechanical treatment of the metal up to the time of the test. By geometry is meant the configuration of the specimen, such as the overall dimensions and the size, shape, and location of the notch.

† This terminology has already been accepted by the various agencies working under the Bureau of Ships of the Navy Department, the U.S. Coast Guard, and the National Defense Research Committee for current studies of the structures and the materials of welded merchant vessels.

GENERAL CONSIDERATIONS

The exploration of the effects of variation of the four parameters mentioned, i.e., history, geometry, temperature, and speed of loading, even when it is limited to the simple determination of whether fracture is by cleavage or shear, is still an immense task. One way to break this task down is to maintain one parameter, say the rate of strain, approximately constant, and to vary the other three while attention is focused upon them. In current work at the Taylor Model Basin this is being done. The average strain rate in all tests is of the order of $10^{-4} \frac{1}{\text{sec}}$, and the history, geometry, and temperature are varied.

The complexity of the problem, which involves the plastic behavior of metals, is very great; the best treatment of the subject in brief form is given by Gensamer (5). A systematic attack on this whole problem needs the collaboration of many agencies. Several of these are already working directly on the plastic behavior of ship steel, and others are active in closely related lines. A central office is needed to receive, digest, and promptly make known to all of the agencies concerned the plans, progress, and test results of each of these agencies as they relate to the subject. From such a service of information, a general agreement on the main elements of the problem and methods of attack might be expected.

In the meantime most of the work now underway at the different agencies still has the character of reconnaissance. Such is the nature of the tests described in the present report.

TEST SPECIMENS AND PROCEDURE

The present series consisted of eight test specimens. The specimens were cut from medium steel plating $\frac{3}{4}$ inch thick with the length of the specimens parallel to the direction of rolling; they were 24 inches long and 12 inches wide.

The specimens were designed and tested to show the effect of certain variables on the type of fracture. The variables were: 1) three degrees of sharpness of the notch; 2) temperature; 3) history, such as strain aging in the region of the notch, and local heating and quenching of the plate in the region of the notch.

All of the specimens were notched at midlength and midwidth. Data on the form of the specimens are given in the sketch, Figure 1. Three of them, Specimens 113, 114, and 115, each had a notch consisting of a simple circular hole 2.4 inches in diameter. The remaining width in way of the notch was thus 9.6 inches; the net area was 7.2 square inches.

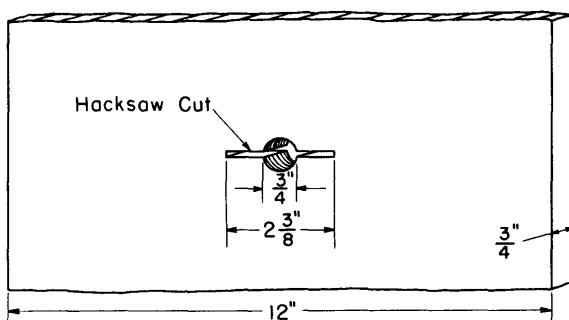

Figure 1a - Sketch of Specimens 110, 111, and 112

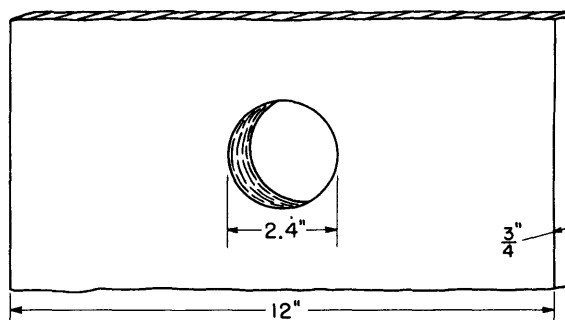

Figure 1b - Sketch of Specimens 113, 114, and 115

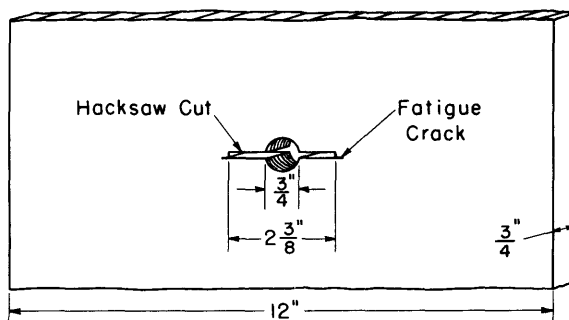

Figure 1c - Sketch of Specimens 116 and 117

Figure 1 - Form of Tensile Test Specimens

All specimens were 24 inches long. Specimens 113, 114, and 115 contained a hole 2.4 inches in diameter. Each of the other specimens contained a hole $\frac{3}{4}$ inch in diameter with a hacksaw cut on either side which brought the total width of the notch to $2\frac{3}{8}$ inches. In Specimens 116 and 117 fatigue cracks about $\frac{3}{32}$ inch long were developed at the end of each sawcut before testing.

The other five specimens had approximately the same net area in way of the notch, but they had a different type of notch. In these specimens the notches were formed by drilling a hole $\frac{3}{4}$ inch in diameter and then making a hacksaw cut $\frac{13}{16}$ inch long from each side of the hole on the diameter perpendicular to the long edge of the plate. In two of these specimens, 116 and 117, shallow fatigue cracks were induced at the ends of the sawcuts by cyclic loading in the alternating-load testing machine. Thus the notches in these two specimens had the same sharpness as natural cracks. The additional length of each of these cracks was about $\frac{3}{32}$ inch.

Without systematic investigation of the effects of history, two of the notched specimens were given treatment affecting their history. Specimen 114 was heated locally with a torch played on the inner surface of the hole and then quenched by immersion in water. Although it is realized that the plate was of low carbon steel and therefore would not be greatly affected by such treatment, the treatment was considered significant since it is similar to that sometimes used in shrinking and straightening operations in shipbuilding.

Specimen 112 was cold-worked mechanically with a severity not unlike that encountered in the fabrication of ship hulls. After the plate was

notched, it was bent lengthwise as a beam until it took a permanent bow of about 1 inch, by a load applied through a fulcrum of about 1/2 inch radius, placed transversely at midlength. It was then turned over and bent out of flat the same amount in the opposite direction. It was finally straightened to its original flatness. The strain-aging resulting from this operation was expedited by heating at about 200 degrees fahrenheit for 2 hours.

The surfaces of the specimens were ruled with longitudinal and transverse lines, as shown in the photographs following, to give a visual indication of the strain pattern as plastic deformation took place.

After the specimens were prepared for testing, the remaining variable was the temperature at which the specimens were tested. The main point of interest in these tests was the nature of the fracture, i.e., whether the plates ruptured in the cleavage or the shear mode. It was desired to so choose the temperatures at which the different tests were conducted that some of the specimens of each group would break in the shear mode and others in the cleavage mode. Thus the temperature at which the transition from shear to cleavage rupture occurred would be bracketed within a certain temperature range. This was not always accomplished because of the limited number of specimens of each type available for test.

TEST RESULTS

The results of the tests are summarized in Table 1.

Specimen 110 was tested at a temperature of 75 degrees fahrenheit. It broke with a ductile cleavage fracture as can be seen from the photograph, Figure 3 on page 9.

Specimen 111, which was similar to Specimen 110, was tested at a temperature of 100 degrees fahrenheit. It broke with a ductile shear rupture as shown in Figure 4 on page 11.

Specimen 112 was similar to Specimen 111 except that it was cold-worked mechanically and strain-aged as described in the preceding section. When tested at a temperature of 100 degrees fahrenheit, it broke with a cleavage fracture.

Specimen 113 contained a hole 2.4 inches in diameter. When tested at a temperature between 80 and 90 degrees fahrenheit it failed with a ductile shear rupture as shown in Figure 5 on page 13.

Specimen 114 was identical with Specimen 113 except that it was heated and quenched as described in the preceding section. It was tested at a temperature of 75 degrees fahrenheit. This specimen exhibited a large amount of plastic elongation before cracking, which started as a ductile

TABLE 1

Results of Static Tension Tests of Medium Steel Plate

The tests were made to study the effect of temperature and of the sharpness of the notch on the type of fracture.

Specimen	Width of Hole and Notch inches	Temperature degrees fahrenheit	Maximum Load kips	Stress at Maximum Load kips††	Fracture	Remarks
110	2 3/8 Notch 3/4 Hole	75†	303	42.0	Cleavage	Cleavage fracture 1 1/8 inch long at 302 kips load followed by complete cleavage fracture at a load of 303 kips.
111	2 3/8 Notch 3/4 Hole	100	341	47.3	Shear	Crack visible at surface at a load of 330 kips.
112	2 3/8 Notch 3/4 Hole	100	358	49.5	Cleavage	Plate strain-aged by bending and heating.
113	2.4 Hole	85†	435	60.5	Shear	Normal shear rupture.
114	2.4 Hole*	75†	454	63.0	Shear then Cleavage	Cleavage fracture when increasing load to 329 kips after the shear cracks had progressed 2 1/4 inches at the left side of the hole and 3/4 inch at the right side.
115	2.4 Hole	75†	421	58.5	Shear	Normal shear rupture.
116	2 3/8 Notch** 3/4 Hole	70†	278	39.5	Cleavage	Short initial cleavage fracture at each end of slot at a load of 261 kips (37 kips!).
117	2 3/8 Notch** 3/4 Hole	100	330	46.9	Shear	Normal shear rupture.

* The periphery of the hole in Specimen 114 was heated to above the critical temperature and quenched in water.

** In Specimens 116 and 117 a fatigue crack 3/32 inch long was started at each end of the sawcut to determine the effect of a very sharp notch compared to that of the sawcut notch of Specimens 110 and 111.

† The reduced temperature for Specimens 113, 114, 115, and 116 was obtained by cooling with ice; Specimen 110 was tested on a cool day at a temperature of 75 degrees. In nearly all of these tests the temperature around the notch increased because of plastic straining.

†† The abbreviation kipsi is used to designate thousands of pounds per square inch.

shear rupture and then shifted to a cleavage fracture, as may be seen in Figure 6 on page 15.

Specimen 115 was identical with Specimen 113. It was tested at a temperature of 75 degrees fahrenheit; rupture was in the shear mode.

Specimen 116 was similar to Specimen 110 except that it contained shallow fatigue cracks at the ends of the sawcuts. When tested at a temperature of 70 degrees fahrenheit it broke with a cleavage fracture.

Specimen 117 was identical with Specimen 116. When tested at a temperature of 100 degrees fahrenheit it broke with a shear rupture.

A representative true-stress-strain curve obtained from the test data on three standard 0.505-inch round tensile test specimens machined from the plate from which the specimens were cut is given in Figure 2.

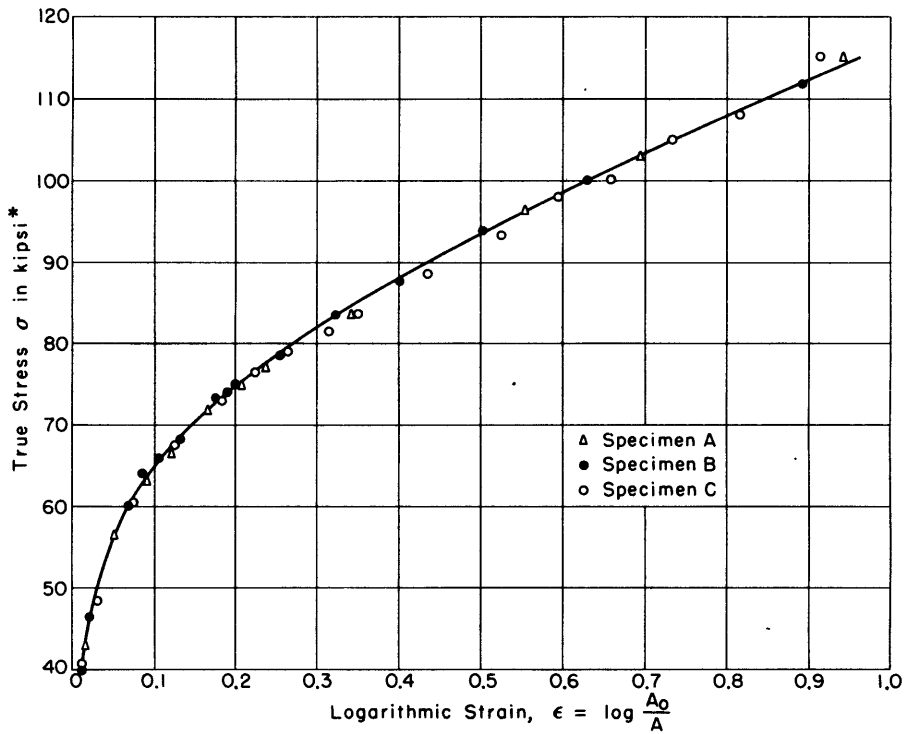

Figure 2a - Data Plotted on Rectangular Coordinates

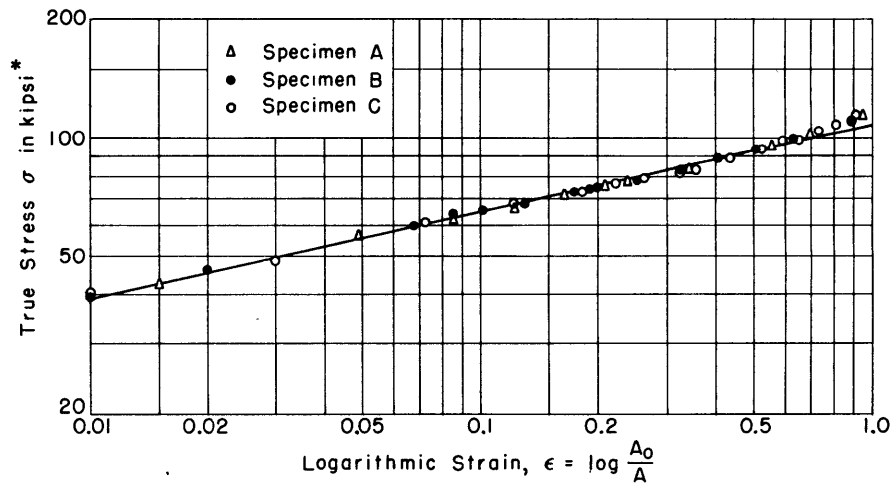

Figure 2b - Data Plotted on Log-Log Coordinates

Figure 2 - True Stress-Strain Curve for the Medium Steel of the Specimens Described in This Report

The experimental points may be represented by the analytical expression $\sigma = 108 \epsilon^{0.224}$ as evidenced by the linearity of the data in Figure 2b. The slope of the line is 0.224 and the intercept at $\epsilon = 1.0$ is 108. In this plot σ is the true stress and $\epsilon = \log \frac{A_0}{A}$ is the natural or logarithmic strain.

It should be noted that as the logarithmic strain approaches unity the experimental points lie above the straight line drawn.

* The abbreviation kipsi is used to designate thousands of pounds per square inch.

(For the convenience of the reader in referring to the figures, this page is left blank so that related text and figures appear on facing pages.)

DISCUSSION OF TEST RESULTS

Although observations of the mode of rupture under different test conditions were the main object of these tests, they actually give much more information. Much can be learned from the photographs, Figures 3 to 6. For example, the ductile cleavage fracture of Specimen 110 which was tested at a temperature of 75 degrees fahrenheit is shown in Figure 3. Figure 3c shows the square break, the granular surface, and the herringbone or chevron pattern characteristic of cleavage fractures.

It is to be noted that the form of the grid lines after rupture, as shown in Figure 3b, indicates little evidence of permanent deformation except in the immediate vicinity of the ends of the slot. The sawcut has increased to several times its initial width and the grid lines at the ends of the cut show considerable local deformation. At the left end of the notch there is a distinct dimple which indicates localized decrease in thickness. It is clear that before the cleavage fracture started high values of plastic strain existed at this point; their effect on elongation is small, however, because the area of high strain is extremely localized.

At the right end of the slot, Figure 3b, a rather curious feature appears. It will be observed that whereas the left end of the slot opened because of plastic flow at its end, the right end opened by parting of the plating. The nature of this fracture is shown in Figure 3c. It has the appearance of a thumb print in the metal itself on both halves of the ruptured specimen. The region inside the print probably broke first with a cleavage fracture, with the point of initial fracture at mid-thickness about $1/8$ inch from the end of the sawcut. The cleavage fracture next spread over the entire area inside the print but the small area at the edge of the print remained ductile and elongated appreciably before final fracture of the remaining section. In fact, it was possible to insert a thin knife blade into the print from the end of the slot for a considerable distance before there was any visible opening in the side of the plate.

The feature just described has been observed frequently in other tests. The parting apparently starts inside the plate and extends over an appreciable area before it can be seen from the surface. However, the presence of the internal crack is disclosed by local plastic flow in the surface.

As previously mentioned, the fracture of Specimen 110 was apparently initiated at mid-thickness about $1/8$ inch from the end of the slot. A close study of Figure 3c reveals a small area at each end of the slot, resembling the half-moon of a fingernail. It is towards this area that the chevrons converge. Consequently, the rim of this area is considered to be the origin of the fracture.

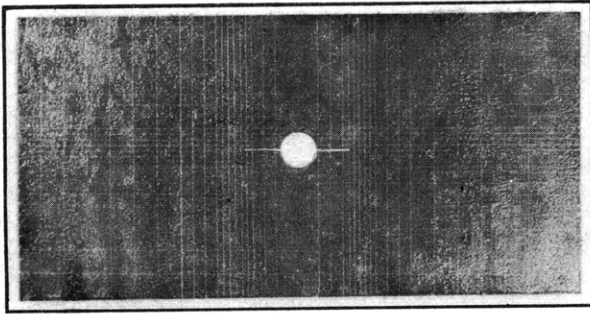

TMB 12327

Figure 3a - The Notch and Rectangular Grid before Elongation

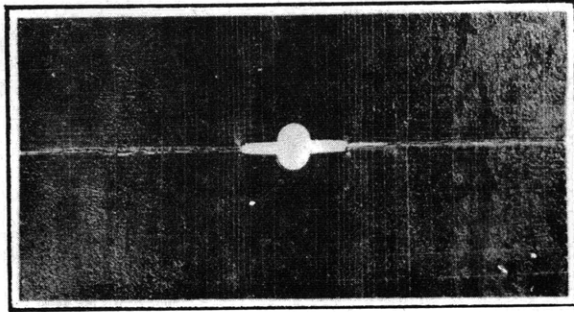

TMB 12329

Figure 3b - The Separated Parts Rejoined after Fracture

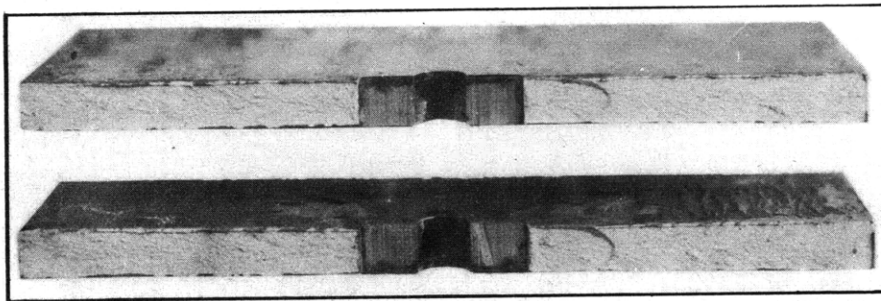

TMB 12331

Figure 3c - The Two Faces of the Fracture Surface

Illumination is from above on the right; the oval areas are both recessed.

Figure 3 - Specimen 110 before and after Ductile Cleavage Fracture

This specimen was tested at a temperature of 75 degrees fahrenheit.

The fracture occurred in two abrupt stages. At an average stress on the net area of 42 kipsi* there was a sudden fracture which extended through most of the thumb print, accompanied by considerable noise. This fracture caused the load to fall off about 3 per cent. When the load was reapplied the average stress on the remaining net section had to be increased to 47 kipsi before complete rupture occurred. Had the testing machine contained a greater amount of stored-up energy, it is probable that parting would have been complete at the first rupture. A characteristic of most testing machines is that a sudden increase in elongation of the specimen reduces the applied load; in a ship structure the load is rarely decreased by a partial fracture and thus the stress on the unfractured section, instead of falling off, is actually increased in proportion as the area is decreased.

* The abbreviation kipsi is used to designate thousands of pounds per square inch.

As previously mentioned, the only difference between the test conditions for Specimens 110 and 111 was in the temperature. Specimen 110 was tested at 75 degrees fahrenheit whereas Specimen 111, which was identical, was tested at 100 degrees fahrenheit. Specimen 111 failed with a ductile shear fracture as shown in Figure 4. In Figure 4a a moderate elongation has already occurred. Figure 4b shows additional elongation and dimples similar to those in Figure 3b, but so far without rupture. The average stress at this stage was 46 kipsi. Tearing began at a slightly increased load, as may be seen in Figure 4c. At this stage the load reached its maximum value of 341 kips, resulting in an average stress on the net section of 47.3 kipsi. As load was reapplied to the specimen, the crack progressed slowly across the plate towards either edge. The test was discontinued at the stage shown in Figure 4d where the nominal stress on the remaining section had risen to about 56 kipsi.

The oblique fracture surface is characteristic of the ductile shear method of rupture. However, it should be pointed out that since the notch is cut square across the plate, the surface of parting first starts in the plane of the notch and then shifts to the oblique configuration. Although it cannot be seen in the photograph, the small area of initial rupture is very similar to the half-moons of Figure 3c.

The rise of the average true stress in the remaining net area as the crack progresses across the plate is the result of strain-hardening. The relation existing between the true stress and the natural strain of the material throughout the plastic range to rupture is shown in Figure 2. The fact that large increases of strain in the plastic region cause only relatively small increases in stress indicates that the stress on the unbroken section is essentially uniform.

Specimen 112 failed in a mode almost identical to that of Specimen 110 even though it was tested at a temperature of 100 degrees fahrenheit. The moderate strain-aging was sufficient to change the mode of rupture from the ductile shear mode as observed in Specimen 111, tested at the same temperature, to a ductile cleavage fracture.

Of the five remaining specimens, the notches of three consisted merely of holes 2.4 inches in diameter, whereas the other two models, Specimens 116 and 117, were similar to Specimens 110, 111, and 112 except that very sharp, natural cracks about $3/32$ inch long were started at each end of the sawcuts by repeated reversals of load.

The greater acuity of the notches in Specimens 116 and 117 caused no perceptible change in the mode of fracture as compared with Specimens 110 and 111. Specimen 116 which was tested at approximately the same temperature

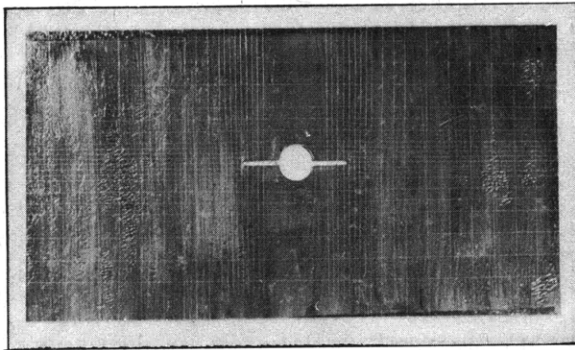

TMB 12365

Figure 4a - An Early Stage of Elongation

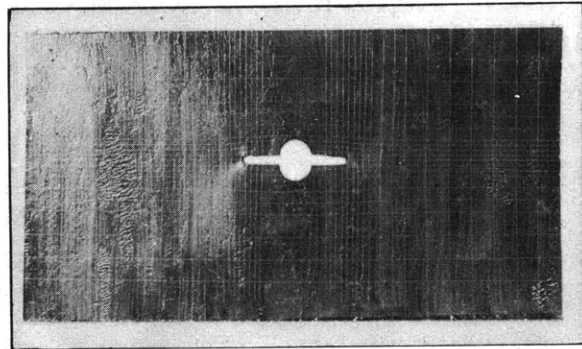

TMB 12359

Figure 4b - Intense Local Strain at Ends of Notch

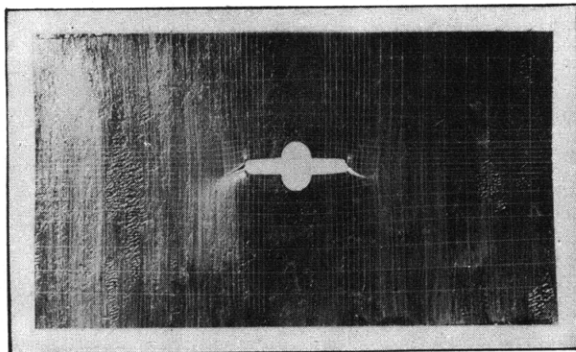

TMB 12367

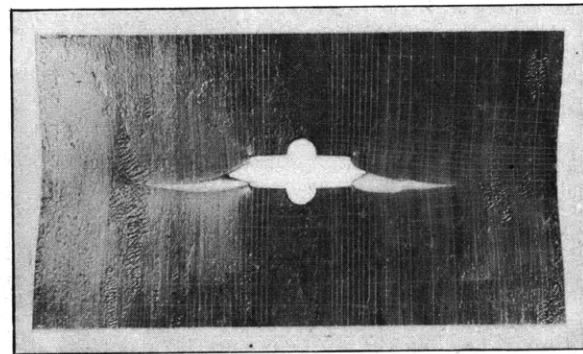
Figure 4c - Shear Rupture Begins
Load Reaches Maximum

TMB 12360

Figure 4d - Specimen after Rupture
The surface of rupture is on a shear plane about
45 degrees to the direction of loading.

Figure 4 - Specimen 111 before and after Ductile Shear Rupture

This specimen was tested at a temperature of 100 degrees fahrenheit.

as Specimen 110 failed with a ductile cleavage fracture. The average stress on the net section was 39.5 kipsi as compared to 42 kipsi for Specimen 110. Specimen 117 which was tested at the same temperature as Specimen 111 failed with a ductile shear fracture. The average stress on the net section was 46.9 kipsi as compared to 47.3 kipsi for Specimen 111. These small differences in maximum stress at rupture are considered not significant. Consequently, the results of these four tests show no significant difference between the behavior of the specimens notched with a sawcut and those notched with a natural crack.

It should be emphasized that these results are very meager and cannot be considered as conclusive. For example, it is well established (6) that in impact testing there is a wide scatter in energy values in the narrow temperature band representing the transition range between cleavage fracture and shear rupture. Presumably the present tests were made in or near this transition temperature and fairly wide scatter of results is to be expected. The fact that the results are so consistent may be entirely accidental and due to the small number of tests.

Of the three specimens containing drilled holes, Specimens 113 and 115 were tested in the as-rolled condition at temperatures of 85 and 75 degrees fahrenheit respectively, whereas Specimen 114 was heated and quenched on the face of the hole as previously described, and tested at a temperature of 75 degrees fahrenheit.

Specimen 113, tested at a temperature of 85 degrees fahrenheit, was very ductile, failing in a shear rupture. It will be observed from the photograph, Figure 5, that this particular type of notch permits the material to deform in a ductile manner with little restraint. Figure 5b shows considerable necking at the edges of the plate. However, because of the deformation of the hole, the material in way of the hole is not restrained appreciably in the transverse direction and its behavior is similar to that of material in a simple tensile test.

The maximum load reached corresponded to an average nominal stress on the net section of about 60.5 kipsi. This is approximately the same tensile strength as obtained from a standard tensile specimen and indicates that the presence of such a hole in a plate has little effect on the average stress at which rupture occurs.

Specimen 115, identical with Specimen 113, was tested at a temperature of 75 degrees fahrenheit, and likewise failed with a ductile shear fracture after considerable elongation. The maximum average stress on the net section was 58.5 kipsi as compared to 60.5 kipsi for Specimen 113. This small difference in ultimate strength of the two specimens is considered not significant.

Figure 5a
Before Elongation

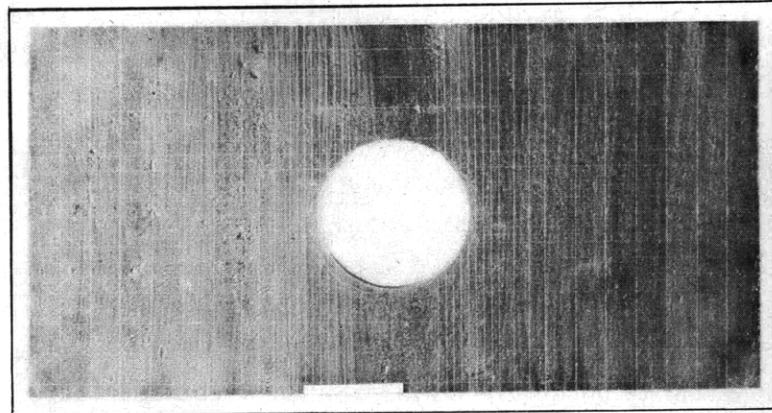

TMB 12380

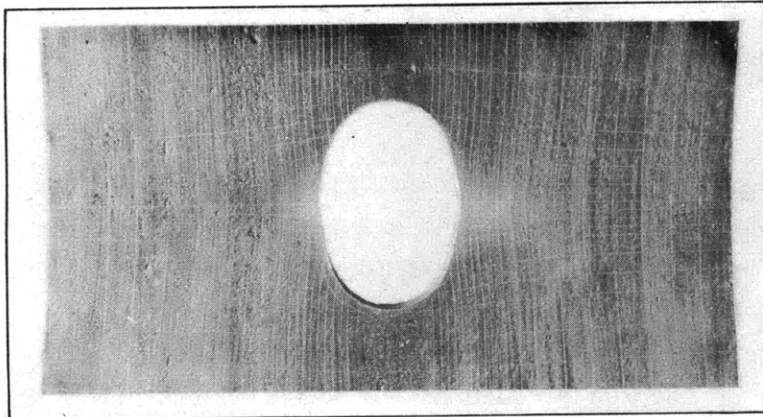

TMB 12383

Figure 5b
Rupture at the Sides of
the Hole is Imminent

Figure 5c
After Complete Rupture

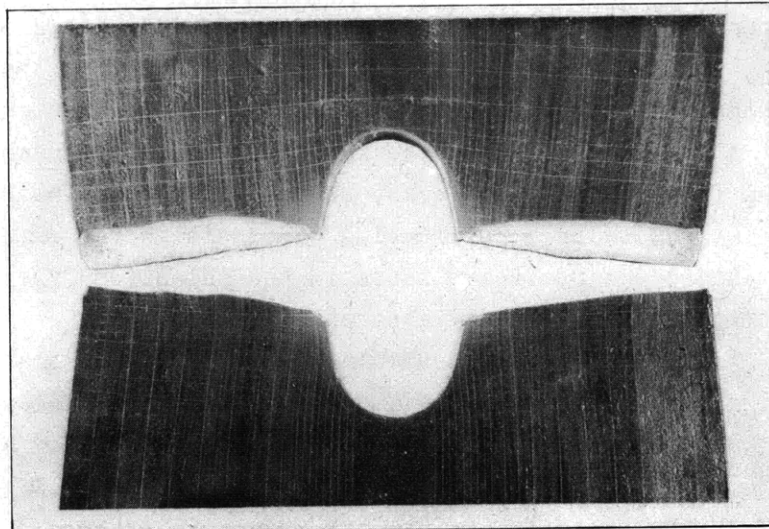

TMB 12384

Figure 5 - Specimen 113 before and after Ductile Shear Rupture

This specimen was tested at a temperature of 85 degrees fahrenheit.

Specimen 114, similar to Specimen 115 except for the heating and quenching just mentioned, was tested at the same temperature as Specimen 115. The deformation of this specimen during test is shown in Figure 6. It will be observed that after a considerable amount of plastic elongation a shear rupture started at each side of the hole. The average stress at maximum load, just prior to the rupture shown in Figure 6c, was 75 kipsi. Although this particular specimen carried the highest load of any of the three specimens with circular holes, the fact is considered not significant. The maximum spread in the values of ultimate strength from the mean value is less than 4 per cent. Such a spread might well occur had the three specimens been tested under identical test conditions. It is believed that the zoned appearance around the hole, Figures 6b, 6c, and 6d, is not of any particular significance, but that it resulted from the angle of lighting and from uneven condensation of moisture on the cooled surface.

DISCUSSION OF TEST PROGRAM

Again it should be emphasized that the tests of the present series were qualitative only. The main information sought was to determine how the type of rupture was affected by temperature. This information was obtained on a very small number of specimens. It is dangerous to generalize on the results of such a small number of tests, and especially to try to read significance into the minor features of the tests, such as the shape of the notch during successive stages of the test, the maximum load at rupture, and the mean stress on the net section at any given stage of the test.

The present tests have indicated that the tensile testing of notched plates can yield significant information on the probable performance of the material in service in the presence of unavoidable stress-raisers in the form of welding cracks, structural discontinuities, and the like. They show promise of supplementing or possibly even surpassing the usefulness of standard Charpy impact tests in the selection of material suitable for construction where energy absorption is involved.

Future tests should be so controlled that they will yield more significant data. For example, the rate of application of load should be under control so that it can be made constant for any series of tests. The temperature should likewise be well under control. If the tests are to be conducted under static conditions, the load should be applied so that the temperature remains essentially constant during the test. The actual temperature of the specimen within the immediate vicinity of the notch can be determined by the use of thermocouples secured to the plate and insulated from

Figure 6a
Before Elongation

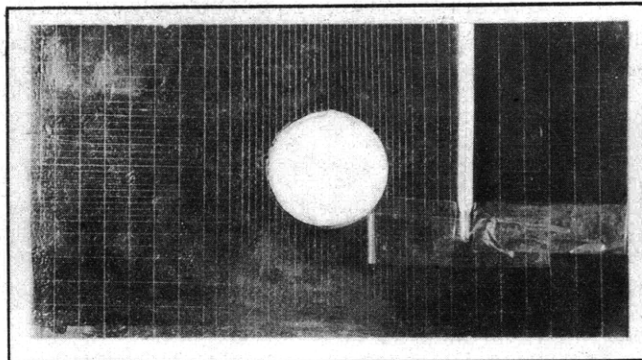

TMB 12395

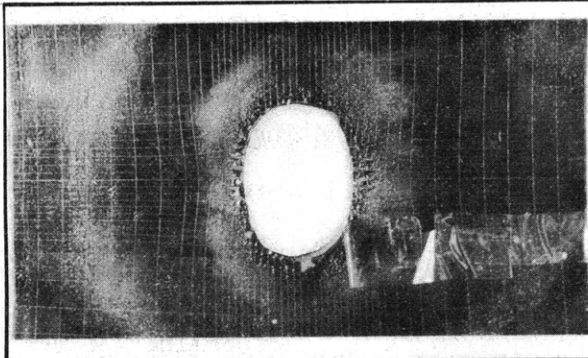

TMB 12398

Figure 6b
Intense Local Strain
at Sides of Hole

Figure 6c
Partial Rupture in Shear Mode

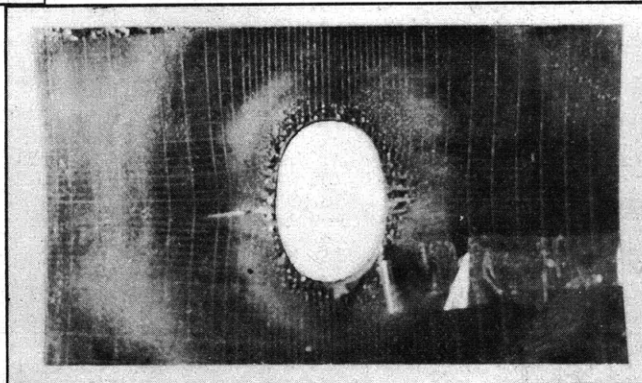

TMB 12400

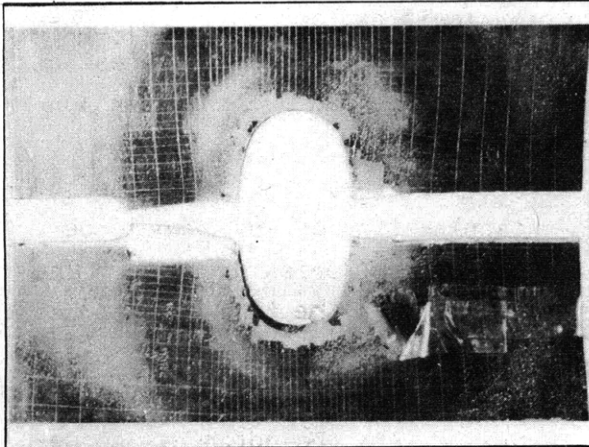

TMB 12399

Figure 6d
Parting Changed to
Cleavage Mode

Figure 6 - Cleavage Fracture Preceded by Initial Shear Rupture in Specimen 114

This specimen was tested at a temperature of 75 degrees fahrenheit. The mottled appearance around the hole is due to drops of water on the plate. The thermometer used to gauge the temperature was attached to the specimen, as shown in Figure 6a, by scotch tape.

the coolant. This temperature can readily be controlled to within 1 or 2 degrees fahrenheit, which should be sufficient for tests of this type.

If the tests are to yield results that can be correlated with the results of impact tests, energy absorption should be measured. Total energy absorption can be readily obtained from a plot of total elongation against load. The significance of total energy absorption is rather doubtful. The local energy absorption at the root of the notch is much more significant, but in many cases this may be only a small portion of the total energy absorbed.

Measurement of the distortion of a photographically applied grid of closely spaced lines appears at present to offer the best means of evaluating these local energy values. If an accurate evaluation of the energy absorption at the end of the notch can be made, there is a possibility that in general the failures starting at notches can be correlated and explained.

SUGGESTED METHOD OF ANALYSIS

The strain grid for Specimen 113 shown in Figure 5b is reproduced to an enlarged scale in Figure 7. It will be observed that the grid lines, which were originally straight and parallel to either the x- or y-axis, have become distorted. If the separation of the various lines is measured and compared with the original spacing of the lines, the distribution of the principal strains in the vicinity of the hole can be estimated. From these data and the stress-strain curve of Figure 2, the distribution of the octahedral shearing stress and the energy absorbed per unit volume in any given region can be obtained (7). It is also sometimes possible to obtain these same values by determinations of the change of thickness in any given region (8).

A method of applying grids by photographic processes has been used satisfactorily on aluminum sheets and steel tubes (9). This technique is being investigated for use in connection with future tests at the Taylor Model Basin and elsewhere.

It is of interest to note that the stress-strain curve can be represented by a very simple analytical expression of the form $\sigma = k\epsilon^n$ up to true strains of about 1 (10)(11). Within the range of strains encountered in the rupture of ship plating, this expression is suitable for analytical work. The exponent n is the true strain at which necking begins.

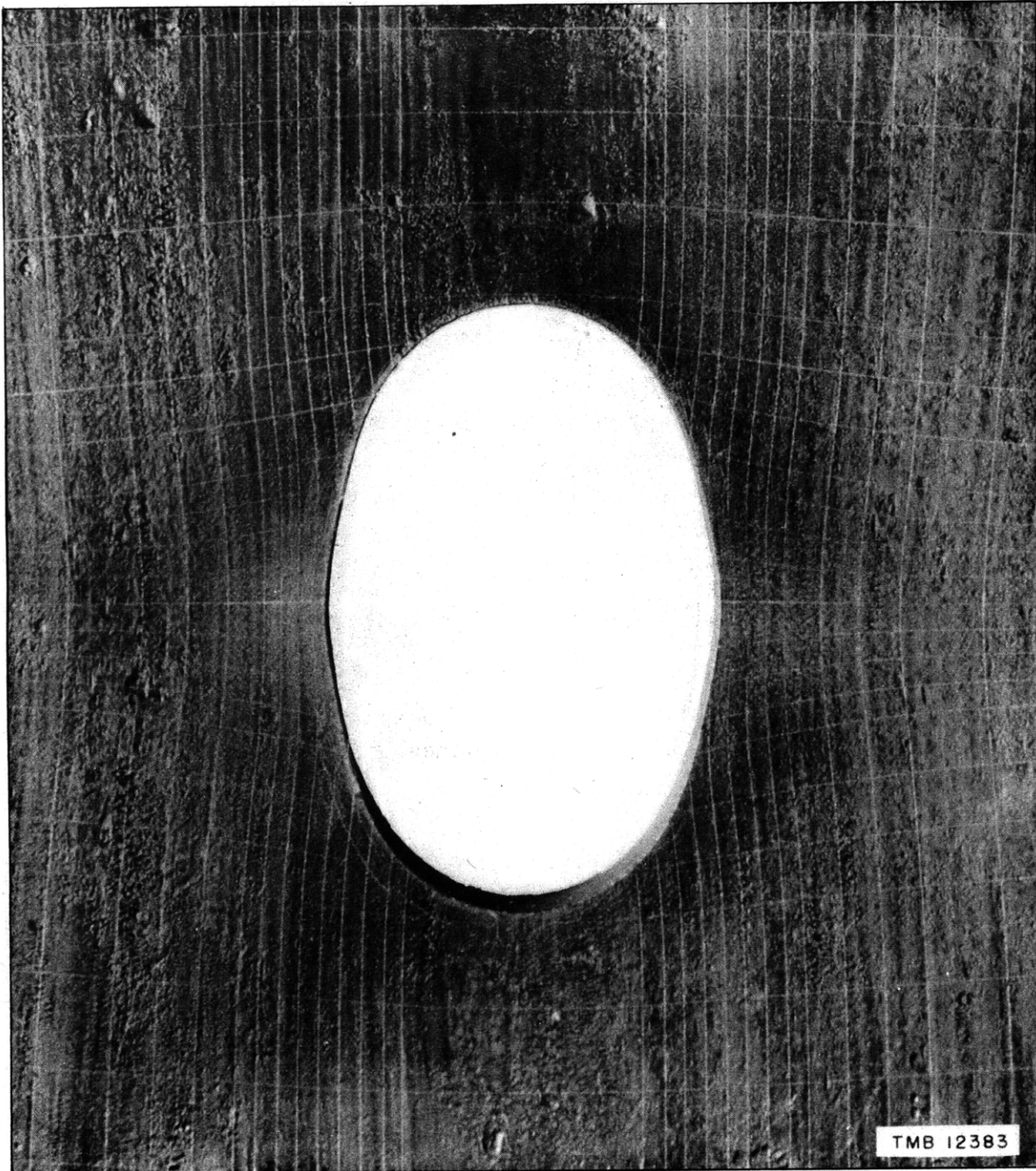

Figure 7 - Pattern of Strain Distribution, Specimen 113

The maximum strain approaches the limit which will be accepted by the material before rupture.
The rectangular grid prior to strain is shown in Figure 5a.

CONCLUSIONS

The results of the present series of tests are qualitative only. They show that for the medium steel specimens used in these tests:

1. A ductile cleavage fracture is obtained in notched plates at a temperature of 75 degrees fahrenheit, whereas a ductile shear rupture is obtained at a temperature of 100 degrees fahrenheit. A similar specimen strained by bending and heating gave a ductile cleavage rupture at a temperature of 100 degrees fahrenheit.

2. The use of natural fatigue cracks instead of sawcuts did not affect the type of fracture.

3. Circular notches caused ductile shear ruptures at temperatures of 75 degrees and 85 degrees fahrenheit.

RECOMMENDATIONS

In all future tests it is recommended that

1. the rate of loading be accurately controlled,
2. the temperature in way of the notch be held constant,
3. the total energy be determined by noting the loads and corresponding total elongations,
4. the reduction of thickness as a function of the distance from the fractured surface be determined,
5. the strain distribution in way of the notch be determined by the use of grid lines closely and accurately spaced.

REFERENCES

- (1) "Welding Test 206 - Physical Characteristics of Welded Longitudinal Seams," TMB CONFIDENTIAL Report R-129, March 1943.
- (2) "The Brittle Failure of Medium Steel in Ship Structures," by Captain W.P. Roop, USN, TMB CONFIDENTIAL Report R-207, October 1943.
- (3) "Welding Test 207 - Tensile Strength of Butt Welds Made in 40-Pound Special Treatment Steel," TMB CONFIDENTIAL Report R-249, to be published.
- (4) "Notes on the Conditions of Brittle Rupture of Ship Plates of Medium Steel," by Captain W.P. Roop, USN, TMB Report R-276, July 1944.
- (5) "Strength of Metals Under Combined Stress," by Maxwell Gensamer, The American Society for Metals, 1941.

(6) "Report of Investigation of Charpy Impact Resistance of Medium Steel for Ship Construction at Normal and Subnormal Temperatures," Material Laboratory, New York Navy Yard, Report 3179-19, December 31, 1941.

(7) "Progress Report on Underwater Explosion Research, Bureau of Ships Symbol E139, Part 10 - A Method for Determining the Energy Absorption of Thin Steel Diaphragms under Hydrostatic Pressure," by M.A. Greenfield, TMB CONFIDENTIAL Report R-248, May 1944.

(8) "Progress Report on Underwater Explosion Research, Bureau of Ships Symbol E139, Part 20 - Calculation of the Principal Strains of Small, Thin Diaphragms Dynamically Loaded," by B. Stiller and A.R. Cohen, TMB CONFIDENTIAL Report R-265, July 1944.

(9) This photo-grid process as applied to steel tubes will be described in a forthcoming report by Dr. Le Van Griffis in connection with NDRC Research Project NRC-77.

(10) "Tensile Stress-Strain Curves," by Lt. John H. Hollomon, Ordnance Dept., USA, Watertown Arsenal Laboratory Experimental Report Number WAL 630/7-1, 1 November 1943.

(11) "The Notched-Bar Impact Test," by John H. Hollomon, Welding Journal, April 1945, pp. 230-s to 244-s.

