

MIT LIBRARIES

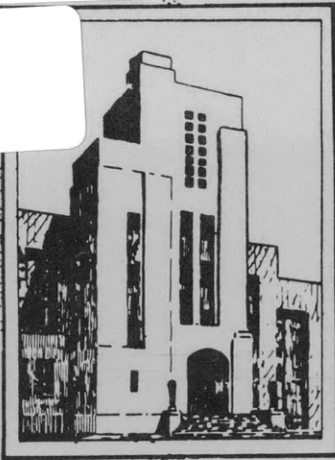

3 9080 02993 0614

V393
.R468



DEPARTMENT OF THE NAVY
DAVID TAYLOR MODEL BASIN

HYDROMECHANICS

ON THE PERFORMANCE OF A PROPELLER
BEHIND A SHIP

(Sul Funzionamento Dell'Elica Associata Ad Una Carena)

AERODYNAMICS

by
[Redacted]
Dr. Ing. Aldo Melodia, Italy
[Redacted]

STRUCTURAL
MECHANICS

APR 10 1959

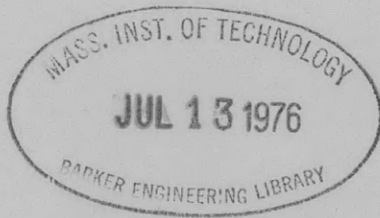

Translated by CDR J.W. Shultz, Jr. USN

APPLIED
MATHEMATICS

January 1959

Translation 286

This translation to be distributed only
within the continental limits of the United
States and its Territories.

**ON THE PERFORMANCE OF A PROPELLER
BEHIND A SHIP
(Sul Funzionamento Dell'Elica Associata Ad Una Carena)**

by

**Dr. Ing. Aldo Melodia
La Marina Italiana, Vol. 53, No. 12, 1955, pp. 309-314**

Translated by CDR J.W. Shultz, Jr. USN

January 1959

Translation 286

SUMMARY

Recalling the classical concepts of analysis of self-propelled model tests, the author here proposes and describes a method of total identity, i.e., of both thrust and power, by means of which, considering a rotary wake as well as an axial wake, the relative rotative efficiency is reduced to unity.

After defining the notions of a single-valued performance criterion, as opposed to a criterion based on either thrust or torque (power) alone, and of effective propeller speed, he examines by means of the method of total identity some particular cases of propulsion and the probable relationships between nominal wake velocity, effective velocity and thrust deduction.

1. The Analysis Method of R. Froude

The analysis of self-propelled tests of a propeller behind a ship is made, as is well known, by comparing the performance of the ship-borne propeller with the open-water performance characteristics. The comparison is based on the assumption that, at equal rpm, the propeller efficiency and the speed of advance, for the two conditions of operation, are equal when the thrusts are equal.

This analysis method was proposed by R. Froude in 1883 together with the well-known equation which coordinates the factors which are derived separately from towing tests and from self-propelled model tests. Froude's equation is:

$$\frac{\text{ehp}}{\text{shp}} = \frac{1-t}{1-w} \eta_p \eta_{rr}$$

where ehp is the effective horsepower required by the hull as determined by towing tests of the model,

shp is the shaft horsepower delivered to the propeller hub as determined by self-propelled model tests,

$1-t = R/T$ is the relationship between resistance R determined by towing and the thrust T determined by self-propelled tests,

$1-w = V_A/V_S$ where V_A is the open-water propeller speed of advance for the same rpm and thrust and V_S is the ship model speed in towing and self-propelled tests,

η_p is the propeller efficiency from open-water tests at the same values of rpm and thrust, and

η_{rr} is a numerical factor called "relative rotative efficiency" which is used to establish arithmetic equality between the two sides of the equation.

Even though Froude's equation is only an arbitrary convention, since it coordinates logically but not physically three different nonsimultaneous phenomena, nevertheless it has

proven to be a very useful tool for investigation and even today it constitutes the common reference base for all self-propelled tests.

In Froude's equation, η_{rr} generally has values other than unity because of the fact that under conditions of constant thrust there are not generally conditions of constant power. For equal thrusts, the greater the difference between open water and "behind" shaft horsepowers, the greater is the difference between η_{rr} and unity. In the case where the two values of shaft horsepower coincide, $\eta_{rr} = 1$.

Since Froude's method is based on constancy of rpm, both the criterion of power identity and the criterion of thrust identity can be transformed respectively into criteria of torque coefficient identity and of thrust coefficient identity.

The analysis, therefore, can be made in nondimensional terms by use of the open-water propeller curves, which, according to current practice, are represented in the form of a graph (Figure 1) whose abscissa gives the advance coefficient

$$J = \frac{V_A}{nd}$$

and whose ordinates gives the thrust coefficient

$$K_T = \frac{T}{\rho n^2 d^4}$$

the torque coefficient

$$K_Q = \frac{Q}{\rho n^2 d^5}$$

and the propeller efficiency

$$\eta_p = \frac{K_T}{K_Q} \cdot \frac{J}{2\pi}$$

The open-water propeller curves define the performance of propellers throughout the propulsion range from conditions of zero speed of advance to zero thrust. When, from self-propulsion tests at a given ship speed, values of thrust, shaft horsepower and rpm are obtained, then K_T and K_Q can be calculated. For these values of K_T or K_Q , the open-water curves (Figure 2) give values of J_T , J_Q , η_{pT} and η_{pQ} , and permit determination of V_{AT} and V_{AQ} and therefore of w_T and w_Q . It is necessary, of course, to consider as consistent only those values having the same subscript.

Since we have from towing tests values of resistance and effective horsepower, Froude's equation can be solved for η_{rrT} and η_{rrQ} .

$$\eta_{rrT} = \frac{\text{ehp}}{\text{shp}} \times \frac{1}{1-t} \times \frac{1-w_T}{\eta_{pT}}$$

or

$$\eta_{rrQ} = \frac{\text{ehp}}{\text{shp}} \times \frac{1}{1-t} \times \frac{1-w_Q}{\eta_{pQ}}$$

2. Relative Rotative Efficiency

While the notions of wake fraction and thrust deduction have clear physical foundations in the propulsion phenomena, not so much can be said concerning the notion of relative efficiency introduced by R. Froude in his equation of efficiencies.

Many opinions have been expressed about the physical significance of the factor η_{rr} , and today the one given the most credit considers relative rotative efficiency as an index and as a consequence of the nonuniformity of the flow entering the propeller. According to Professor van Lammeren, in those cases where the relative rotative efficiency is greater than unity, the favorable influence of the radial nonuniformity is greater than the unfavorable influence of the circumferential nonuniformity.

A series of special experiments is being conducted by Professor van Lammeren at the water tunnel to determine experimentally the effect of nonuniformity of flow on propeller efficiency. Further, Professor Burrill, by applying some well-known theoretical concepts of aerofoil theory to a propeller operating in a radially variable wake, finds, mathematically, a theoretical efficiency greater than that obtained when the same propeller operates in a uniform wake.

Professor Telfer, after having keenly observed that relative efficiency is, in the final analysis, a "question of internal accounting," has proposed its elimination by substituting for the wake fraction resulting from the criterion of thrust identity, an arbitrary wake fraction:

$$w' = 1 - \frac{1-w_T}{\eta_{pT}}$$

From an experimental point of view, relative rotative efficiency assumes values which are not always predictable with sufficient accuracy. It does not follow any rule, and this fact constitutes a serious drawback from the point of view of propeller design. Moreover, it varies according to the method utilized, with the result that one set of results from self-propelled tests can lead to two series of coefficients: One based on assuming thrust identity and one based on assuming torque identity. Many authors think it advisable to report both results.

American towing basins, instead, follow the rather debatable system of reporting the mean values of the coefficients and efficiencies obtained by applying separately the two

classical criteria of identity (thrust and torque).

Relative rotative efficiency is generally greater than unity for centerline propellers, for which the following relationships hold:

$$\eta_{rrT} > 1$$

$$\eta_{PQ} > \eta_{PT}$$

$$J_Q > J_T$$

$$w_Q < w_T$$

For off-center propellers, on the other hand,

$$\eta_{rrT} < 1$$

$$\eta_{PQ} < \eta_{PT}$$

$$J_Q < J_T$$

$$w_Q > w_T$$

In the case of off-center propellers, one must bear in mind the possible contrarotative effect of the appendages which support the propeller shaft assuming that it has noticeable influence on the wake fraction and on the value of relative rotative efficiency.

3. The Rule of Total Identity

A characteristic common to all well-known methods of analysis is that of considering as fixed the value of propeller rpm. This amounts to neglecting a possible rotative component of the hull's wake. The existence of a rotating wake is generally admitted, but its importance is considered to be negligible (Gawn, NEC, 1938), except for the case where it is artificially produced with a counter-rotative wake producer (contrapropeller).

The assumption of rpm and thrust identity implies the determination of unique values for the other two variables of propeller operation: shaft horsepower and speed of advance. If the power, shp' , thus determined does not agree with the measured power, shp , the relative rotative efficiency differs from unity and is given by

$$\eta_{rrT} = \frac{\text{shp}'}{\text{shp}}$$

Since both the shp and the thrust T are the results of direct measurement on the ship's shafting installation, while the other two quantities which define the operation of the propeller, and therefore the effective rpm and speed of advance, are dependent on the hydrodynamic conditions of operation of the propeller itself, it appears possible, by introducing the notion of rotary flow to reduce automatically to unity the value of rotative efficiency and, finally to eliminate it from the efficiency equation.

This method can be called the "rule of total identity." It can be applied relatively easily by the method of successive approximations, determining, for example, for several values of n' , close to n , the corresponding values of J_T and J_Q . By entering curves of J_T and J_Q plotted as a function of n' , the value of n_o results, determined by $J_T = J_Q = J_o$.

From the value J_o one gets the value of V_o of the speed of advance and finally the value

$$\frac{V_o}{V_s} = 1 - w_o$$

and the value of η_{p_o} corresponding to J_o .

Analysis by means of the method of total identity, that is, the determination of n_o , V_o and η_{p_o} , can therefore be accomplished much more rapidly by constructing on the open-water characteristic curves a new nondimensional coefficient independent of rpm:

$$K_o = \left(\frac{K_T}{K_Q} \right)^2 K_T$$

whence

$$K_o = \left(\frac{2 \pi T}{550 D \times \text{shp}} \right)^2 \frac{T}{\rho}$$

This latter expression makes it possible, with the measured values of thrust and horsepower, to calculate the value of K_o for the ship-borne propeller and, with this value of K_o , to enter the open water characteristic curves (Figure 3).

Then, from the values of K_{T_o} , and J_o and η_{p_o} thus obtained, it is possible to calculate

$$n_o = \left(\frac{T}{\rho D^4 K_{T_o}} \right)^{\frac{1}{2}}$$

$$V_o = J_o n_o D$$

$$1 - w_o = \frac{V_o}{V_s}$$

The values of n_o and V_o are those that satisfy the condition of total identity and thus thrust identity and shaft horsepower identity. Analogous to the above expression for w_o is the

following expression for the rotary wake fraction:

$$\mu = 1 - \frac{n_o}{n}$$

or

$$1 - \mu = \frac{n_o}{n}$$

4. Application of the Rule of Total Identity

The practical application of the rule of total identity to given cases of self-propulsion provides the values of wake fraction w_o , propeller efficiency η_{p_o} , and the rotary flow coefficient μ and permits comparison with the values w_T , η_{p_T} and η_{rr} which are obtained by applying the classical method of thrust identity. The results of some of this work are given in Table 1:

TABLE 1
Comparison of Results Obtained by (1) the Criterion of Thrust Identity and
(2) the Criterion of Total Identity

No.	Reference	w_T	η_{p_T}	η_{rr_T}	w_o	η_o	μ
1	SNAME 1948	0.364	0.606	1.100	0.470	0.554	0.064
2		0.458	0.493	1.038	0.505	0.448	0.021
3		0.330	0.600	1.025	0.360	0.587	0.022
4		0.390	0.606	1.028	0.416	0.596	0.015
5		0.349	0.585	1.044	0.443	0.562	0.024
6		0.425	0.525	1.028	0.464	0.503	0.018
7	Kempf 1938	0.290	0.624	1.091	0.421	0.555	0.076
8		0.492	0.463	1.028	0.560	0.412	0.023
9		0.420	0.452	1.071	0.545	0.380	0.034
10		0.364	0.467	1.085	0.468	0.423	0.026
11	Yamagata 1938	0.365	0.470	1.140	0.537	0.391	0.087
12		0.370	0.475	1.100	0.488	0.425	0.061
13		0.360	0.470	1.130	0.496	0.418	0.071
14		0.395	0.515	1.120	0.492	0.482	0.051
15		0.395	0.470	1.085	0.482	0.437	0.040
16		0.390	0.410	1.105	0.556	0.330	0.058
17		0.390	0.365	1.120	0.634	0.245	0.062
18	Rome 1953	0.070	0.674	0.938	0.001	0.678	-0.042
19		0.070	0.635	0.933	0.007	0.632	-0.038
20		0.074	0.673	0.914	-0.018	0.675	-0.065
21		0.040	0.740	0.905	-0.078	0.751	-0.054

Table 1 covers cases of propulsion of single- and twin-screw ships where values of relative rotative efficiency differ appreciably from unity. Examples 1 through 6 refer to a series of American tankers for which data was published in SNAME Transactions, 1948. Examples 7 through 10 are taken from a paper by Prof. Kempf of 1938. Examples 11 through 17 are taken from the notable paper of Mr. Yamagata, NEC 1938. Examples 18 through 21 refer to off-center propellers and were taken from self-propelled tests conducted at the Vasca Sperimentale di Roma.

As predicted, the application of the rule of total identity to these cases of self propulsion in which the relative rotative efficiency determined by the thrust method is greater than unity, leads to values of the rotary wake fraction μ which increase as the relative rotative efficiency η_{rrT} increases.

In the cases where $\eta_{rrT} < 1$, that is, for twin-screw hulls, w_o is somewhat less than w_T while μ is negative. This leads one to believe that, for the twin-screw hulls considered, the flow arriving at the propeller has undergone a noticeable counter-rotative effect caused by the particular configurations of the struts.

Examples 14 through 17 refer to the same propeller (No. 317 of Yamagata's paper, mentioned above), the same hull and the same ship speed. Only the propeller load was varied by applying additional resistance to the model. As the load increased, w_T showed practically no variation, whereas w_o and μ increased appreciably.

Figures 4 and 5 show graphically the data of the table. In these figures are seen the approximate relationships between w_o , w_T , and η_{rrT} .

5. Single Criterion for Defining Propeller Performance

The relative rotative efficiency has values other than unity because the advance coefficients determined by classical methods, thrust identity, and torque identity, at a given rpm, yield values which differ from each other. The considerations discussed in the preceding paragraphs have shown the possibility of eliminating ambiguity from the correction factor "relative rotative efficiency" by introducing the notion of rotary flow and by applying the method of total identity. The advantage of this method is made even more evident when, from open-water tests, one plots, against V_A and n , lines of constant power and constant thrust (Figure 6).

It is evident that for every pair of values of shaft horsepower and thrust there is a corresponding pair of values of V_A and n , and vice versa. Of the four variables that define the propeller performance, when two are given the other two are uniquely defined. The value of thrust alone cannot define the operation point if one of the other three variables is not known: n , shp, or V_A . If as in the case of hull model tests, the values of thrust and power are measured, the characteristic curves give the corresponding unique values of V_o and n_o which satisfy the given conditions. Since the ship speed V_S and the shaft rpm n are also measured, it is possible to calculate the axial and rotary wake fractions:

$$w_o = 1 - \frac{V_o}{V_S}$$

$$\mu = 1 - \frac{n_o}{n}$$

Also from the theoretical approach one arrives at the conclusion that, for given values of shp and T , there is one and only one pair of values of V_A and n , which, for the given propeller, satisfies the conditions of operation in water flowing freely into the propeller disk. From propeller theory we get the following expressions for thrust and power of a blade section at radius r (Figure 7):

$$\frac{dT}{dr} = \frac{dL}{dr} \cos \beta_i$$

$$\frac{dP}{dr} = \frac{dL}{dr} \omega r \sin \beta_i$$

where $\frac{dL}{dr}$ is the lift of the section considered, and therefore

$$\frac{dL}{dr} = \rho \Gamma V_r$$

expressing with

$$\Gamma = 4 \pi r \frac{\mu T}{2}$$

the circulation relative to the blade section itself, and with

$$V_r = \left(\omega \cdot r - \frac{\mu T}{2} \right) \frac{1}{\cos \beta_i}$$

the velocity relative to the profile.

In the preceding relationships, $\frac{\mu T}{2}$ is the tangential component of the induced velocity $\frac{\mu}{2}$.

Further, since

$$\frac{dL}{dr} = \pi \rho b V_r^2 \tan \alpha_i$$

where

$$\alpha_i = \phi - \beta_i$$

represents the ideal angle of attack of the section whose geometric pitch angle is ϕ and whose hydrodynamic pitch angle is β_i , we have

$$\frac{dL}{dr} = \pi \rho b V_r^2 \tan (\phi - \beta_i)$$

and

$$\frac{dT}{dr} = \pi \rho b V_r^2 \alpha \cos (\phi - \alpha_i)$$

Since, for a given propeller with a given section, ϕ is known and fixed, the condition

$$\frac{dT}{dr} = \text{constant}$$

is reduced to

$$V_r^2 \alpha_i \cos (\phi - \alpha_i) = \text{constant}$$

and the condition

$$\frac{dP}{dr} = \text{constant}$$

results in

$$V_r^2 \alpha_i w r \sin (\phi - \alpha_i) = \text{constant}$$

The simultaneity of the conditions

$$\frac{dT}{dr} = \text{constant}$$

and

$$\frac{dP}{dr} = \text{constant}$$

results finally in the condition

$$w r \tan (\phi - \alpha_i) = \text{constant}$$

Finally, the velocity curves are uniquely determined and consequently both the speed of advance V_a and the tangential velocity $w r$ are uniquely determined.

Since the reasoning can be repeated for all sections of the blade, it can be concluded that for the mathematical propeller the values of thrust and shaft horsepower define uniquely the values of speed of advance and rpm. Further, it is deduced that the value of thrust (or power) alone results in infinitely possible values of speed of advance and rpm. This conclusion can be expressed by stating that it is not possible to establish any criterion other than

that of total identity, unless one assumes, arbitrarily, that rotary wake and tangential velocity components have no effect.

6. The Effective Velocity of Operation and the Induced Inflow Velocity

The physical quantity which, according to usage, is called speed of advance and is determined by self-propulsion tests, is in effect the speed of advance necessary to permit the propeller operating in open water (and thus in uniform flow) to give the desired thrust or to absorb the desired power, or, according to the rule of total identity described previously to furnish a given thrust at a given power. For this value of speed of advance, the term "effective velocity of operation" is proposed.

This velocity is to be considered in a conventional way, recognizing that it includes the effects not only of the hull ahead of the propeller, but also of the appendages behind the propeller, such as, for example, a rudder or a propeller support.

An interesting parallel to this effect can be drawn from the experimental data published by R. Gawn (NEC 1938), wherein are reported the test results of several propellers tested in open water and with struts placed ahead of and behind the propellers. If the characteristics are plotted in absolute values for one of these propellers, it is seen that the condition of total identity of thrust and power are realized at an rpm and speed of advance less than those measured in open water: thus for $T = 1$ kg and $shp = 2$ kg-met/sec, we get: (Translator's note: This statement appears to contradict the values which follow!)

	Open Water	Struts Ahead	Struts Behind
n_p (rps)	8.98	9.12	9.10
V_A (met/sec)	1.375	1.440	1.445

That is, struts placed astern of the propeller act on the effective velocity and effective rpm in about the same way as struts placed ahead of the propeller.

Except in the case where a counter-rotative flow is intentionally produced, the hull cannot cause a rotary flow, especially in the case of a hull with a centerline propeller. The rotary wake must therefore be attributed to the action of the propeller and must be considered as an induced tangential velocity, analogous to that which is considered in propeller design theory. Since design, for given criteria of thrust and power, does not assume variations in induced tangential velocity, it must be concluded that the induced rotary wake is a result of the changes in inflow conditions.

Similarly if one considers the axial component of the hull's wake, it is observed generally that the results differ from those shown to be necessary by analysis. It must therefore be assumed that, in addition to the induced axial and tangential velocities associated with the performance in open water, for the changed conditions of flow into and out of the propeller

behind a hull the propeller causes a supplementary induced velocity of a magnitude determined by the influence of the hull and its appendages on the open-water flow into and out of the propeller. Figure 8 shows graphically the above thought for a hypothetical case of a single blade section and shows the velocity diagram which describes the operation of the section considered.

7. The Propeller Fixed in Space (Dead Pull)

That the behind propeller can generate an induced velocity is further proven by the fact that during dock trials the thrust produced by the behind propeller is always less than that produced in open water. The difference between the two is about 10 percent. For the dead pull condition, whereas the efficiency itself tends linearly to zero, the coefficient K_o is proportional to K_T .

$$K_o = \left(\frac{K_T}{K_Q} \right)^2 K_T = \left(\frac{2\pi\eta}{J} \right)^2 K_T$$

The rule of total identity can thus be applied by computing K_o for the behind propeller and entering the open-water characteristic curves with the value

$$K_T' = \left(\frac{J}{2\pi\eta} \right)^2 K_o$$

The value of K_T' determines a value of J_o other than zero, which shows that the propeller creates a speed of advance even when, for the particular conditions of operation, the nominal velocity is known to be zero. In a concrete case the effective induced velocity of the propeller obtained during dock trials was about 1.5 meters per second.

8. Probable Relationship between Thrust Deduction, Nominal Velocity, and Effective Velocity

The rule of total identity permits perhaps a more complete picture of the propulsion phenomenon than does the classical rule of Froude. Table 2 gives results obtained by Yamagata of propeller No. 317, mentioned above.

TABLE 2

Experimental Results						Thrust Identity			Total Identity			
ϵ	$T(\text{kg})$	SHP	t	N	ρc	w_t	η_p	$\frac{1-t}{1-w_t}$	w_o	$\frac{1-t}{1-w_o}$	η_o	μ
0.5	20,800	2,120	0.225	82.5	0.73	0.395	0.515	1.28	0.492	1.525	0.482	0.051
1.0	32,300	3,670	0.195	96.1	0.68	0.395	0.470	1.325	0.482	1.555	0.437	0.040
2.0	55,500	7,160	0.175	117.9	0.615	0.390	0.410	1.355	0.556	1.860	0.330	0.058
3.0	78,600	11,260	0.165	135.1	0.56	0.390	0.365	1.375	0.634	2.28	0.245	0.062

The data given in Table 2 refer to the same propeller at a fixed ship speed (14 knots). The nominal velocity determined by direct measurement in the hull's wake while being towed without a propeller was found to be about 9.8 knots ($w_n = 0.30$). The load variation on the propeller was obtained artificially by adding an external resistance to the hull's own resistance. The factor $\epsilon = 1$ indicates normal conditions of self-propulsion. Upon increasing the load from 0.5 to 3.0, it is noted that the thrust deduction decreases noticeably while the wake fraction w_t , determined by the rule of total identity undergoes no appreciable variation. On the contrary, the hull effect increases, but in the same proportion as the decrease in t .

Examining the results in light of the method of thrust identity, one is not able to explain the physical reason why, when, the propeller load increases, the thrust deduction decreases, while the wake fraction remains constant.

On the other hand, if the results are analyzed by the rule of total identity, as the load increases there is an appreciable variation in w_o , which increases with the load. That is to say that the effective velocity of operation of the propeller diminishes with an increase in load. But the nominal velocity, which is unaffected by the propeller, remains constant if the ship speed is constant, for which reason the difference between the nominal velocity and the effective velocity increases with propeller load.

It can be thought that the amount of energy required for the propeller to reach its operating conditions decreases as the load on the propeller increases because of an increase in the difference between nominal velocity and effective velocity.

Analysis using the rule of total identity evidences a large recovery of the nominal wake velocity. The unusual values of the hull effect find justification in the unusual conditions of operation of the propeller considered. Finally in the case in question propulsion is described in relatively more advantageous conditions as the propeller load increases. It is worthy of note that the rotary wake has no significant variations throughout the region considered.

9. Future of the Rule of Total Identity

The method of analysis described in the preceding paragraphs can be considered a means of defining the performance of a ship-borne propeller in a way more accurate and pertinent to physical reality than can be done with the classical criterion of thrust identity. From the design point of view, the rule of total identity provides two fundamental elements: the "advance wake fraction" referred to the effective velocity, and the "rotary wake fraction" referred to the effective velocity of rotation. The definition of the optimum propeller for separate cases of propulsion can therefore be based on the two elements, effective velocity and effective rpm, and on either of the other two elements, the required thrust or the available shaft horsepower. The efficiency thus determined will be free of any unknown relative rotative efficiency; and the performance of the propeller, both when using open-water series curves and when designing from aerofoil theory, will have closer correlation with the actual performance of the propeller itself.

10. Conclusion

The rule of total identity, the concepts of effective velocity, effective rpm and single-valued propeller operation, permit the consideration of ship-borne propeller performance from a new point of view, perhaps more closely related to the physical realities of the propulsion phenomenon.

Planned experiments for the future will be able to say whether this is true and to what degree the new concepts can clarify the mechanical complexities of a propeller operating behind a hull.

BIBLIOGRAPHY

Froude, R.E., "A Description of a Method of Investigation of Screw-Propeller Efficiency," Transactions INA (1883).

van Lammeren, W.P.A., "Resistance, Propulsion and Steering of Ships, 1948-Development of Ships Model Research," Transactions INA (1954).

Horn, F., "Measurement Wake," Transactions NEC (1937-1938) - (Ungleichformigkeitsinflüsse bei Schiffschrauben - 1932 - Auswertung von Schraubenversuchen, Schiffbau, 1935).

Yamagata, M., "Optimum Diameter for Single-Screw Ship," Transactions NEC (1937-1938).

Telfer, E.V., "The Wake and Thrust-Deduction of Single-Screw Ships," Transactions NEC (1935-1936); "Marine Propeller and Propulsion Miscellany," Transactions NEC (1951).

Gawn, R.W.L., "Bracket Effects on Propeller Performance," Transactions NEC (1937-1938).

Baker, G.S., "The Qualities of a Propeller Alone and Behind a Ship," Transactions NEC (1937-1938).

Kempf, G., "Further Model Tests on Immersion of Propellers," Transactions NEC (1937-1938).

Burrill, L.C., "The Effect of Radial-Pitch Variation on the Performance of a Marine Propeller," Transactions INA (1953).

Lewis, F.M., "Propeller Coefficients and the Powering of Ships," Transactions SNAME (1951); "Propeller Tunnel Notes," Transactions SNAME (1947).

Leathard, J.F., "Flow Measurement in the Slipstream of a Model Propeller," Transactions INA (1952).

Couch, R.B., and St. Denis, M., "Comparison of Power Performances of Ten 600-Foot Single-Screw Tanker Hulls," Transactions SNAME (1948).

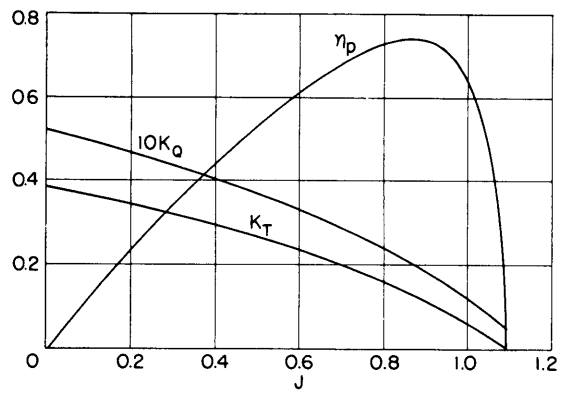

Figure 1

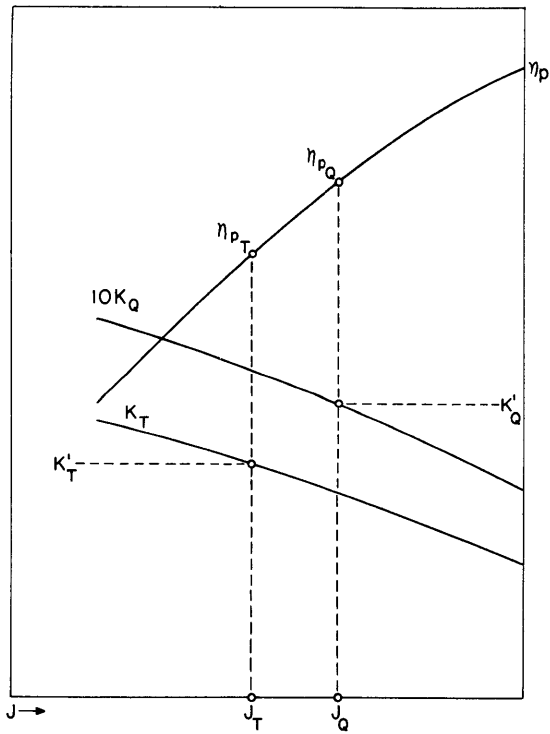

Figure 2

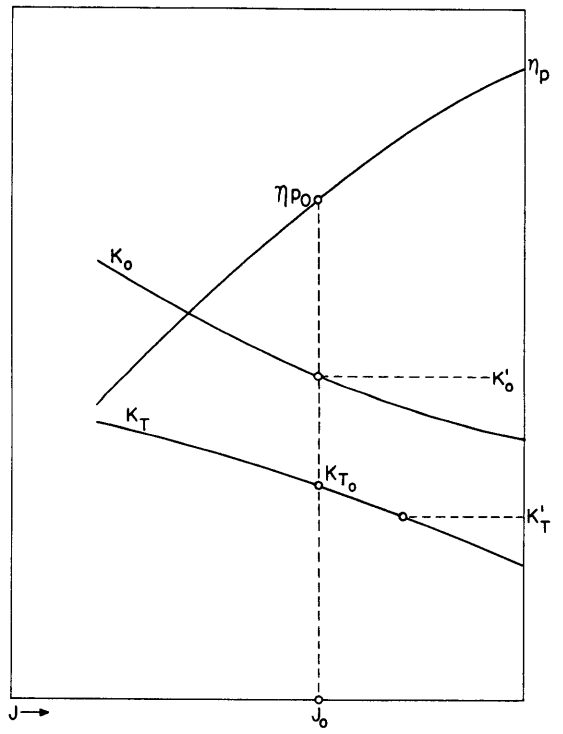

Figure 3

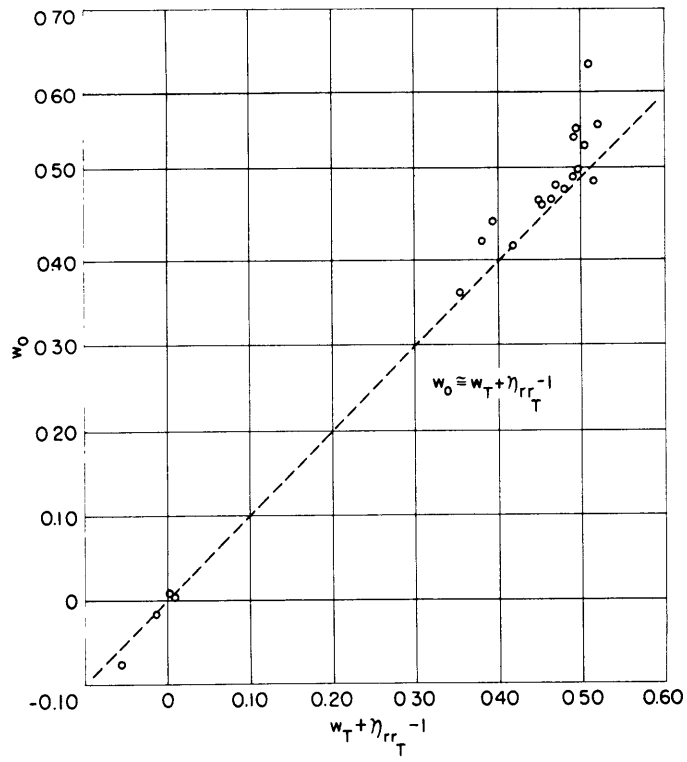

Figure 4

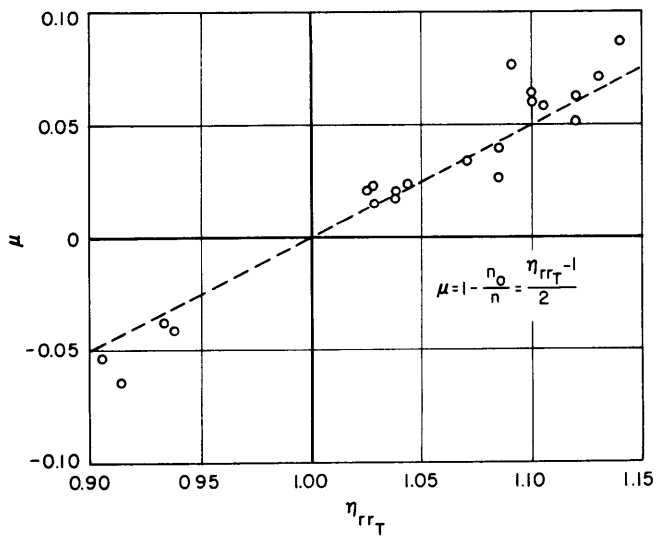

Figure 5

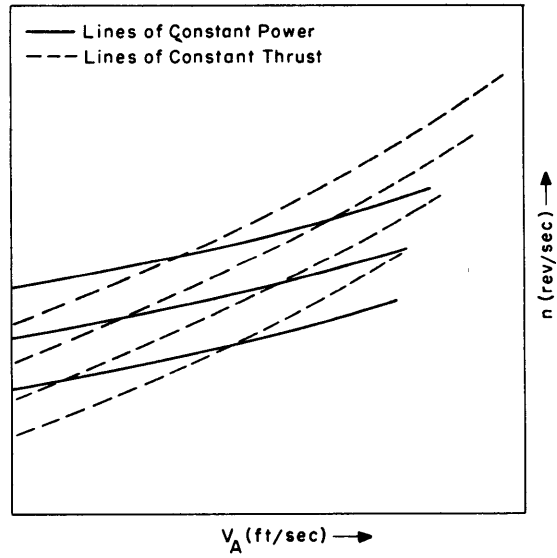

Figure 6

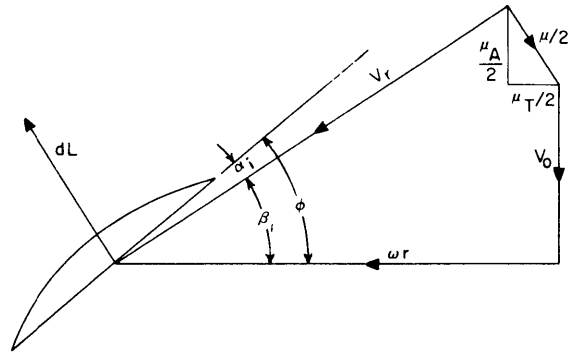

Figure 7

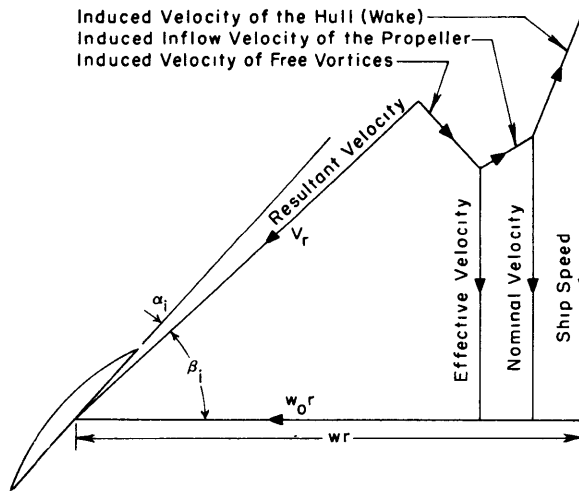

Figure 8

INITIAL DISTRIBUTION

Copies

- 12 CHBUSHIPS, Library (Code 312)
 - 10 Tech Library
 - 1 Tech Asst to Chief (Code 106)
 - 1 Propellers & Shafting (Code 654)
- 4 CNO
 - 2 OP 922-F2
 - 2 OP 923-M4
- 1 CHONR (Code 438)
- 2 SLA Translation Pool, John Crerar Library,
Chicago, Ill.
- 2 OTS Translation Service, Dept of Commerce,
Wash. D.C.

David Taylor Model Basin. Translation 286.
ON THE PERFORMANCE OF A PROPELLER BEHIND A
SHIP (Sul Funzionamento Dell'Elica Associata Ad Una Carena),
by Aldo Melodia. January 1959. 17p. diagrs., graphs, tables,
refs. (Translated by J.W. Shultz, Jr., from La Marina Italiana,
Vol. 53, No. 12, 1955, pp. 309-314.) UNCLASSIFIED

Recalling the classical concepts of analysis of self-propelled model tests, the author here proposes and describes a method of total identity, i.e., of both thrust and power, by means of which, considering a rotary wake as well as an axial wake, the relative rotative efficiency is reduced to unity.

After defining the notions of a single-valued performance criterion, as opposed to a criterion based on either thrust or torque (power) alone, and of effective propeller speed, he examines by means of the method of total identity some particular

1. Ships - Propulsion - Model tests
 2. Propellers (Marine) - Performance
 3. Wakes
 4. Propeller - Hull interaction
- I. Melodia, Aldo

David Taylor Model Basin. Translation 286.
ON THE PERFORMANCE OF A PROPELLER BEHIND A
SHIP (Sul Funzionamento Dell'Elica Associata Ad Una Carena),
by Aldo Melodia. January 1959. 17p. diagrs., graphs, tables,
refs. (Translated by J.W. Shultz, Jr., from La Marina Italiana,
Vol. 53, No. 12, 1955, pp. 309-314.) UNCLASSIFIED

Recalling the classical concepts of analysis of self-propelled model tests, the author here proposes and describes a method of total identity, i.e., of both thrust and power, by means of which, considering a rotary wake as well as an axial wake, the relative rotative efficiency is reduced to unity.

After defining the notions of a single-valued performance criterion, as opposed to a criterion based on either thrust or torque (power) alone, and of effective propeller speed, he examines by means of the method of total identity some particular

1. Ships - Propulsion - Model tests
 2. Propellers (Marine) - Performance
 3. Wakes
 4. Propeller - Hull interaction
- I. Melodia, Aldo

David Taylor Model Basin. Translation 286.
ON THE PERFORMANCE OF A PROPELLER BEHIND A
SHIP (Sul Funzionamento Dell'Elica Associata Ad Una Carena),
by Aldo Melodia. January 1959. 17p. diagrs., graphs, tables,
refs. (Translated by J.W. Shultz, Jr., from La Marina Italiana,
Vol. 53, No. 12, 1955, pp. 309-314.) UNCLASSIFIED

Recalling the classical concepts of analysis of self-propelled model tests, the author here proposes and describes a method of total identity, i.e., of both thrust and power, by means of which, considering a rotary wake as well as an axial wake, the relative rotative efficiency is reduced to unity.

After defining the notions of a single-valued performance criterion, as opposed to a criterion based on either thrust or torque (power) alone, and of effective propeller speed, he examines by means of the method of total identity some particular

1. Ships - Propulsion - Model tests
 2. Propellers (Marine) - Performance
 3. Wakes
 4. Propeller - Hull interaction
- I. Melodia, Aldo

David Taylor Model Basin. Translation 286.
ON THE PERFORMANCE OF A PROPELLER BEHIND A
SHIP (Sul Funzionamento Dell'Elica Associata Ad Una Carena),
by Aldo Melodia. January 1959. 17p. diagrs., graphs, tables,
refs. (Translated by J.W. Shultz, Jr., from La Marina Italiana,
Vol. 53, No. 12, 1955, pp. 309-314.) UNCLASSIFIED

Recalling the classical concepts of analysis of self-propelled model tests, the author here proposes and describes a method of total identity, i.e., of both thrust and power, by means of which, considering a rotary wake as well as an axial wake, the relative rotative efficiency is reduced to unity.

After defining the notions of a single-valued performance criterion, as opposed to a criterion based on either thrust or torque (power) alone, and of effective propeller speed, he examines by means of the method of total identity some particular

1. Ships - Propulsion - Model tests
 2. Propellers (Marine) - Performance
 3. Wakes
 4. Propeller - Hull interaction
- I. Melodia, Aldo

cases of propulsion and the probable relationships between nominal wake velocity, effective velocity and thrust deduction.

cases of propulsion and the probable relationships between nominal wake velocity, effective velocity and thrust deduction.

cases of propulsion and the probable relationships between nominal wake velocity, effective velocity and thrust deduction.

cases of propulsion and the probable relationships between nominal wake velocity, effective velocity and thrust deduction.

David Taylor Model Basin. Translation 286.

ON THE PERFORMANCE OF A PROPELLER BEHIND A SHIP (Sul Funzionamento Dell'Ellica Associata Ad Una Carena), by Aldo Melodia. January 1959. 17p. diags., graphs, tables, refs. (Translated by J.W. Shultz, Jr., from La Marina Italiana, Vol. 53, No. 12, 1955, pp. 309-314.) UNCLASSIFIED

Recalling the classical concepts of analysis of self-propelled model tests, the author here proposes and describes a method of total identity, i.e., of both thrust and power, by means of which, considering a rotary wake as well as an axial wake, the relative rotative efficiency is reduced to unity.

After defining the notions of a single-valued performance criterion, as opposed to a criterion based on either thrust or torque (power) alone, and of effective propeller speed, he examines by means of the method of total identity some particular

1. Ships - Propulsion - Model tests
 2. Propellers (Marine) - Performance
 3. Wakes
 4. Propeller - Hull interaction
- I. Melodia, Aldo

David Taylor Model Basin. Translation 286.

ON THE PERFORMANCE OF A PROPELLER BEHIND A SHIP (Sul Funzionamento Dell'Ellica Associata Ad Una Carena), by Aldo Melodia. January 1959. 17p. diags., graphs, tables, refs. (Translated by J.W. Shultz, Jr., from La Marina Italiana, Vol. 53, No. 12, 1955, pp. 309-314.) UNCLASSIFIED

Recalling the classical concepts of analysis of self-propelled model tests, the author here proposes and describes a method of total identity, i.e., of both thrust and power, by means of which, considering a rotary wake as well as an axial wake, the relative rotative efficiency is reduced to unity.

After defining the notions of a single-valued performance criterion, as opposed to a criterion based on either thrust or torque (power) alone, and of effective propeller speed, he examines by means of the method of total identity some particular

1. Ships - Propulsion - Model tests
 2. Propellers (Marine) - Performance
 3. Wakes
 4. Propeller - Hull interaction
- I. Melodia, Aldo

David Taylor Model Basin. Translation 286.

ON THE PERFORMANCE OF A PROPELLER BEHIND A SHIP (Sul Funzionamento Dell'Ellica Associata Ad Una Carena), by Aldo Melodia. January 1959. 17p. diags., graphs, tables, refs. (Translated by J.W. Shultz, Jr., from La Marina Italiana, Vol. 53, No. 12, 1955, pp. 309-314.) UNCLASSIFIED

Recalling the classical concepts of analysis of self-propelled model tests, the author here proposes and describes a method of total identity, i.e., of both thrust and power, by means of which, considering a rotary wake as well as an axial wake, the relative rotative efficiency is reduced to unity.

After defining the notions of a single-valued performance criterion, as opposed to a criterion based on either thrust or torque (power) alone, and of effective propeller speed, he examines by means of the method of total identity some particular

1. Ships - Propulsion - Model tests
 2. Propellers (Marine) - Performance
 3. Wakes
 4. Propeller - Hull interaction
- I. Melodia, Aldo

cases of propulsion and the probable relationships between nominal wake velocity, effective velocity and thrust deduction.

cases of propulsion and the probable relationships between nominal wake velocity, effective velocity and thrust deduction.

cases of propulsion and the probable relationships between nominal wake velocity, effective velocity and thrust deduction.

MIT LIBRARIES

DUPL



3 9080 02993 0614

